

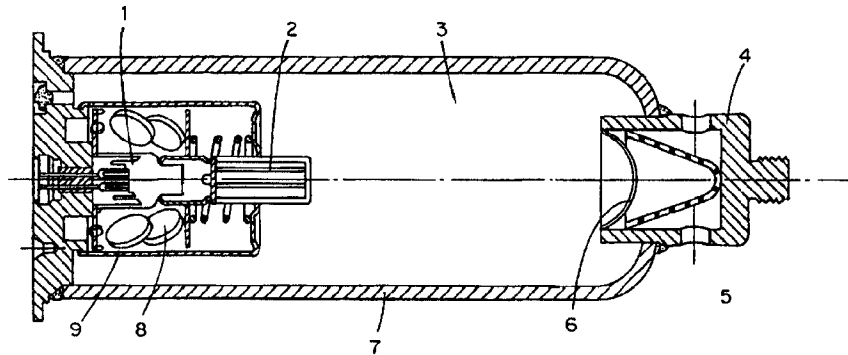

- (72) SIDES, James R., US
(72) MARTIN, James D., US
(72) SCHEFFEE, Robert S., US
(71) ATLANTIC RESEARCH CORPORATION, US
(51) Int.Cl.⁶ B60R 21/26, B60R 21/32

(54) **UTILISATION DE MELANGES DE GAZ DANS DES
GONFLEURS HYBRIDES DE COUSSINS GONFLABLES DE
SECURITE**

(54) **USE OF MIXED GASES IN HYBRID AIR BAG INFLATORS**



PASSENGER SIDE INFLATOR

(57) Des gaz non toxiques exempts de substances particulaires sont produits dans un générateur hybride par allumage de l'agent propulsif et d'un comburant efficace au moyen d'un mélange de gaz moléculaire oxygéné et d'argon, en modifiant le rapport du gaz à l'argon pour obtenir uniquement des produits de réaction non toxiques dans le gaz d'échappement. Le procédé de l'invention comprend un initiateur (1) qui s'enflamme en réponse à un capteur et libère un gaz chaud, lequel allume une charge d'amorce (2), ce qui provoque la combustion de la principale charge génératrice (8) et la production du mélange de gaz de gonflage (3). Lorsque la montée de la pression dans le mélange de gaz a atteint un certain point, le disque d'étanchéité (6) se rompt, laissant le mélange de gaz sortir du collecteur (4) par les orifices de décharge (5) et gonfler un coussin gonflable de sécurité. Le récipient (9) de la charge génératrice retient la principale charge génératrice (8). Toutes les charges et le mélange de gaz de gonflage sont logés dans le réservoir sous pression (7).

(57) Particulate-free non-toxic gases are generated in a hybrid generator device by conducting the ignition of the propellant with an effective oxidizer, using a mixture of a molecular oxygen-containing gas and argon by varying the ratio of the gas to argon to provide only non-toxic reaction products in the exhaust gas. The inventive device includes an initiator (1), which ignites in response to a sensor and gives off hot gas that ignites the ignition charge (2) which causes the main generant charge (8) to combust, generating the inflation gas mixture (3). When the pressure in the gas mixture increases to a certain point, the seal disc (6) ruptures permitting the gas mixture to exit the manifold (4) through the outlet ports (5) and inflate an air bag. The generant container (9) holds the main generant charge (8). All the charges and the inflation gas mixture are enclosed in the pressure tank (7).



PCT

WORLD INTELLECTUAL PROPERTY ORGANIZATION
International Bureau

INTERNATIONAL APPLICATION PUBLISHED UNDER THE PATENT COOPERATION TREATY (PCT)

<p>(51) International Patent Classification ⁶ : B60R 21/26, 21/32</p>	<p>A1</p>	<p>(11) International Publication Number: WO 98/08716</p> <p>(43) International Publication Date: 5 March 1998 (05.03.98)</p>
<p>(21) International Application Number: PCT/US96/13826</p> <p>(22) International Filing Date: 29 August 1996 (29.08.96)</p> <p>(71) Applicant: ATLANTIC RESEARCH CORPORATION [US/US]; Suite 600, 1577 Spring Hill Road, Vienna, VA 22182 (US).</p> <p>(72) Inventors: SIDES, James, R.; 5945 Wellington Road, Gainesville, VA 22065 (US). MARTIN, James, D.; 5945 Wellington Road, Gainesville, VA 22065 (US). SCHEFFEE, Robert, S.; 5945 Wellington Road, Gainesville, VA 22065 (US).</p> <p>(74) Agents: PRESTA, Frank, P. et al.; Lowe, Price, Leblanc & Becker, Suite 300, 99 Canal Center Plaza, Alexandria, VA 22314 (US).</p>		<p>(81) Designated States: AL, AM, AT, AU, AZ, BB, BG, BR, BY, CA, CH, CN, CZ, DE, DK, EE, ES, FI, GB, GE, HU, IL, IS, JP, KE, KG, KP, KR, KZ, LK, LR, LS, LT, LU, LV, MD, MG, MK, MN, MW, MX, NO, NZ, PL, PT, RO, RU, SD, SE, SG, SI, SK, TJ, TM, TR, TT, UA, UG, UZ, VN, ARIPO patent (KE, LS, MW, SD, SZ, UG), Eurasian patent (AM, AZ, BY, KG, KZ, MD, RU, TJ, TM), European patent (AT, BE, CH, DE, DK, ES, FI, FR, GB, GR, IE, IT, LU, MC, NL, PT, SE), OAPI patent (BF, BJ, CF, CG, CI, CM, GA, GN, ML, MR, NE, SN, TD, TG).</p> <p>Published <i>With international search report.</i></p>
<p>(54) Title: USE OF MIXED GASES IN HYBRID AIR BAG INFLATORS</p>		
<div style="text-align: center;"> <p>PASSENGER SIDE INFLATOR</p> </div>		
<p>(57) Abstract</p> <p>Particulate-free non-toxic gases are generated in a hybrid generator device by conducting the ignition of the propellant with an effective oxidizer, using a mixture of a molecular oxygen-containing gas and argon by varying the ratio of the gas to argon to provide only non-toxic reaction products in the exhaust gas. The inventive device includes an initiator (1), which ignites in response to a sensor and gives off hot gas that ignites the ignition charge (2) which causes the main generant charge (8) to combust, generating the inflation gas mixture (3). When the pressure in the gas mixture increases to a certain point, the seal disc (6) ruptures permitting the gas mixture to exit the manifold (4) through the outlet ports (5) and inflate an air bag. The generant container (9) holds the main generant charge (8). All the charges and the inflation gas mixture are enclosed in the pressure tank (7).</p>		

USE OF MIXED GASES IN HYBRID AIR BAG INFLATORSField of the Invention

The present invention relates generally to a method of generating non-toxic gases without particulates and to an improvement in a hybrid inflator for producing said non-toxic gases and, especially for use in generating the
5 gases for a vehicle occupant restraint.

The art is replete with types of inflators for inflating an air bag employed in an inflatable restraint system. Among the types of inflators is one that
10 utilizes a quantity of stored compressed gas which is selectively released to inflate the air bag. A related type generates a gas source from a combustible gas-generating material which, upon ignition, provides a quantity of gas sufficient to inflate the air bag. In
15 still another type, the air bag inflating gas is provided by the combination of a stored compressed gas and the combustion products of the gas generating material. The latter type is known as a hybrid inflator.

In the past, hybrid inflators have been subject to certain disadvantages. The burning of the propellant and
20 the initiation materials in such inflators resulted in the production of undesired particulate matter. The employment of particulate-containing inflator emissions to inflate an air bag might result in the particulates
25 being passed into the vehicle and inhaled by the occupants thereof.

Aside from the gas borne particulate material being inhaled by the passengers in the vehicle, such
30 particulates, if dispersed and airborne, might give the appearance of smoke and cause undue concern that a fire would be present.

As is well known in this field, air or other gas and solid gas generating material are stored in a container. If there is a high rate of vehicle deceleration, indicative of a collision, the gas in the container is released to inflate a vehicle occupant restraint, i.e., an air bag, which restrains and protects the occupant of the vehicle from serious injury. Upon the occurrence of a high rate vehicle deceleration, such as occurs in a vehicle collision, the gas generating material is ignited. As said gas generating material burns, it forms hot expanded gases or vapors which heat and mix with the stored gas, and the heated mixture of gases rushes into the air bag.

Description of the Prior Art

The present invention involves the use of mixtures of oxygen or air with argon, or the like, to permit one to control the oxidation level of the total propellant. Fuel rich solid propellant formulations may be varied and the amounts of oxygen to argon also varied so that the exhaust products of said fuel rich formulation give non-toxic products, exemplified by carbon dioxide, water vapor and nitrogen.

Hybrid inflators have generally used a solid propellant to heat argon gas to inflate an air bag. One of the problems with hybrids has been the amount of particulates from the $KClO_4$ oxidizer used in the propellant. Particulates can be eliminated through the use of propellant compounds such as 5-aminotetrazole (5-AT), aminoguanidine nitrate (AGN) or mixtures thereof. Also, as the oxidizer, ammonium nitrate may be substituted for the $KClO_4$.

The above concept is not taught in the prior art. In U.S. Patent 4,909,549, at column 3, beginning at line 48, the inventors describe the use of gases comprising a primary gas mixture diluted with a secondary gas mixture

(air) that provides several advantages. The benefits enumerated include cooling the primary gas mixture by dilution, thus avoiding the potential for burning the occupants of an aircraft or automobile in which the crash bag is utilized. The air dilution of the primary gas mixture reduces the level of toxic species present to much lower, acceptable levels. Thus, the employment of tetrazole or triazole compounds containing hydrogen in the molecule is practical, since the concentration of hydrogen in the gas produced can generally be reduced by oxidation to very low levels. Nevertheless, the reference does not disclose or suggest controlling the ratio of argon to oxygen as taught by the present inventors.

In U.S. Patent 5,199,740, at column 5, hot potassium chloride, as well as other constituents in the heated gases produced by the burning of the propellant, is described as entering the pressure vessel and impinging upon the inside wall of the vessel part. As the heated products of combustion enter the pressure vessel, the temperature of the pressurized argon gas will increase rather uniformly. When the temperature of the argon gas rises, its pressure will increase to a level which will cause the rupture of the outlet burst disc disposed in a step bore, thereby permitting the gases to flow through the exit openings in the manifold. Clearly, the foregoing is alien to the concept of the present invention where the addition of varied amounts of oxygen to argon enables the exhaust products of fuel rich formulations to be controlled to give non-toxic products. Such addition further permits the use of higher gas mixture temperatures to be attained than are produced with a propellant and air, because of the low heat capacity of argon and some unidentified unique property of this gas. Therefore, at a given gas mixture temperature, less argon and oxygen are needed, resulting

in the capability of employing a reduced system size without compromising the system's effectiveness.

5 In U.S. Patent 5,348,344, the specification, at column 1, beginning at line 48, discloses the provision of an inert gas, preferably nitrogen or argon (column 3) or a mixture thereof, with a fuel gas which is preferably hydrogen and/or methane, but may be any other flammable gas. The oxidizer gas is preferably oxygen. In one
10 embodiment of the invention, the containing means is a single container for holding the inert gas, the fuel gas and the oxidizer gas as a mixture of gases. In another embodiment, a first container holds the fuel gas, a second confines an excess of the oxidizer gas and the containing means defines a combustion chamber in which
15 the fuel gas and oxidizer gas are received and in which the mixture of gases is ignited.

By the above method, the rate of inflation of and the pressure in the inflatable device can be controlled by selecting the amount of fuel gas and oxidizer gas to
20 yield a desired burning rate which in turn fixes the predetermined volumetric rate of flow of warm gas into the inflatable device. Additionally, the rate of inflation can be controlled by flow control orifices or the like through which the gas flows into the inflatable
25 device. It is apparent that the reference does not evince an appreciation for the criticality of the argon's presence and, thus, describes a device and method materially different from those concerned with the invention herein.

30 In U.S. reissue patent 29,228, at column 2, beginning at line 35, the inventor describes an embodiment wherein the confinement is inflated under the influence of a high velocity source of fluid, said fluid being a gas generator of the solid-propellant rocket
35 motor type. The gas generator provides a high velocity stream of hot gas which cooperates with a nozzle to draw

the large volume of air into confinement. The hot gas is cooled by the large volume of air so that the container is not heated to excessive temperatures. Not only does the reference not disclose the use of argon, but the concept taught in the specification would not have led one skilled in the art to the presently claimed invention.

The attributes of smokeless air bag propellants are listed below:

ATTRIBUTES OF SMOKELESS AIR BAG PROPELLANTS

- Smokeless propellants generate only gaseous combustion products such as CO_2 , H_2O , N_2 , and noble gases (e.g., Ar). Thus, they are limited to the chemical elements C, H, O, N, and noble gases (He, Ar)
- Alkali metal fuels (e.g., NaN_3) and oxidizers (e.g., KClO_4) and alkaline earth oxidizers [e.g., $\text{Sr}(\text{NO}_3)_2$] generate particulates (e.g., Na_2O , KCl , and SrO). Thus, they cannot be used in smokeless propellants
- Gun propellants based on nitrocellulose are excellent smokeless propellants but cannot be used in air bags because of the storage temperature requirement.
- Smokeless propellants containing nitramines, such as RDX and HMX, can withstand high temperature storage and, thus, meet this requirement to be a candidate of or an air bag propellant for use with selective oxygen/argon formulations
- Smokeless propellants containing ammonium nitrate can withstand high temperature storage but not temperature cycling through 50°C . They are precluded because the lower storage temperature is -40°C
- However, smokeless propellants containing ammonium nitrate eutectics have been found to withstand temperature cycling
- These propellants must be carefully formulated to prevent formation of toxic combustion products (i.e., HCN and NO_x)

To describe required and desired characteristics of smokeless hybrid air bag propellants, the following tabulation is provided:

CHARACTERISTICS OF SMOKELESS HYBRID AIR BAG PROPELLANTS

CHARACTERISTICS	REQUIRED	DESIRED
Particulates	<1.0 gram	Zero
Producibility	Cast, extrude, injection mold, or press	Extrude, injection mold, or cast
Stability	95°C	107°C
Sensitivity	Insensitive	Insensitive
Combustion	Complete burn	Complete
Toxicity	Nontoxic	Nontoxic
Exhaust	None	No smell
Gas	Hybrid (argon, air, or O ₂ -argon)	Argon

Detailed Description of the Invention and the Preferred Embodiment

The invention of interest relates to an improvement in inflator technology and provides clean odorless gas without particulates or toxic species for inflating devices such as air bags and the like. In the interest of completeness, a conventional inflator mechanism is depicted in the figure of the drawing. The inflator structure is evident from the labeled diagram.

In the figure depicting a conventional passenger side inflator, the initiator 1. ignites in response to a sensor (not shown) that senses rapid deceleration indicative of a collision. The initiator gives off hot gas that ignites the ignition charge 2. which causes the main generant charge 8. to combust, generating the

inflation gas mixture 3. When the pressure in said gas mixture increases to a certain point, the seal disc 6. ruptures permitting the gas mixture to exit the manifold 4. through the outlet ports 5. and inflate an air bag. 5 The generant container 9. holds the main generant charge 8. All the charges and the inflation gas mixture are enclosed in the pressure tank 7.

10 The following examples demonstrate the efficacy of the disclosed invention. Examples 1-3 disclose certain aspects of the inventors' method. Although Example 4 lacks some of the data provided with the other examples, the example is included in this disclosure to permit a comparison to be made between the presence of toxic products obtained when argon, instead of air, is the 15 hybrid gas in the reactor.

Example 1

Composition: AGN/polycarbonate binder

20	Particulates	0 - 0.2 g
	Producibility	pressed
	Stability	OK - 107°C
	Sensitivity	Insensitive
	Combustion	Complete
	Toxicity	Non-toxic
25	Hybrid gas	Argon/O ₂ or Air
	Igniter	Smokeless

Example 2

Composition: 84.8%/wt HMX with 15.2% HTPB (Arcadene®) as binder

30	Particulates	0 - 0.2 g
	Producibility	Cast or injection molded
	Stability	OK - 107°C
	Sensitivity	Insensitive to ESD and friction
35	Burn rate	
	Combustion	Complete
	Toxicity	Non-toxic
	Hybrid gas	O ₂ /Argon
	Igniter	Smokey

Example 3

Composition: HTPB/Nitramine

	Particulates	0.2g
	Producibility	Cast or injection molded
5	Stability	OK at 107°C
	Sensitivity	Insensitive
	Burn rate	0.15 ips at 1000 psi
	Combustion	Complete
	Toxicity	Non-toxic
10	Hybrid gas	O ₂ /Argon
	Igniter	B/KNO ₃

In the compositions of Examples 2 and 3, a compound, such as isophorone diisocyanate (IPDI), may be included as a curing agent for the hydroxy-terminated butadiene binder.

15 Example 4

Composition: HMX or RDX (nitramine)/HTPB

Toxicity	Exhaust products include toxic amounts of NO _x , NO ₂ and NH ₃
----------	---

Hybrid gas	Air
------------	-----

20 The instant method of generating non-toxic gases without particulates comprises conducting the ignition of the propellant in the presence of an ammonium nitrate oxidizer and using a suitable propellant, e.g., aminoguanidine nitrate or a nitramine, such as RDX and/or

25 HMX¹. In the presence of argon and a molecular oxygen-containing gas, but with a controlled ratio of the molecular oxygen-containing gas to argon to minimize toxic values, the non-toxic reaction products in the exhaust gas include carbon dioxide, H₂O, N₂ and mixtures

30 thereof. By using selected mixtures of molecular oxygen-containing gas with argon, one is able to control the

¹ RDX is 1,3,5-trinitro-1,3,5-triazacyclohexane or cyclotrimethylenenitramine; and

HMX is 1,3,5,7-tetranitro-1,3,5,7-tetraazacyclooctane or cyclotetramethylenetetranitramine

oxidation level of the total propellant so that it falls into a desired range.

Another aspect of the present invention involves the use of a binder with the described propellant. While a polycarbonate binder may be used with the aminoguanidine nitrate (AGN) propellant in the form of a pressed pellet charge, a polyvinyl alcohol (PVA) binder is likewise very effective. The binder will comprise about 5% by weight of the propellant.

The ignition of the propellant takes place in the presence of controlled ratios of argon to oxygen. For example, 21 parts by volume of oxygen are employed with 79 parts by volume of argon. However, depending upon all other conditions, 15 to 30 parts by volume of oxygen might be used with complementary volumes of argon.

By employing a mixture of oxygen with argon and a smokeless propellant, such as 95% aminoguanidine nitrate and 5% of a polycarbonate binder in a pressed pellet charge, the advantage is realized of having the charge non-hygroscopic. However, a particularly preferred formulation involves about 95% by weight aminoguanidine nitrate with about 5% by weight polyvinyl alcohol used with 20% oxygen and 80% argon.

The method of the present invention is well suited for inflating automotive vehicle air bags, used as occupant restraints when a vehicle decelerates rapidly, such as in a collision.

By utilizing means for varying the ratios of molecular oxygen-containing gas to argon, particulates and toxic amounts of nitrogen oxides, ammonia and nitric acid in the exhaust are minimized or at least placed in an acceptable range. Additionally, a smaller size inflator device may be used than would otherwise be required. This is due to the higher gas mixture temperature achievable by the low heat capacity of argon,

permitting the use of reduced amounts of argon and oxygen and thus smaller equipment.

The invention has been described specifically with reference to the particular embodiments disclosed.
5 However, it should be understood that the scope of the invention is broader and is properly defined by the following claims.

WHAT IS CLAIMED IS:

1. A method of generating non-toxic gases without
particulates comprising conducting an ignition of a
propellant composition with an effective oxidizer, using
5 a suitable propellant comprising aminoguanidine nitrate,
in conjunction with a suitable binder, in the presence of
argon and a molecular oxygen-containing gas, and
selectively providing a ratio of said molecular oxygen-
containing gas to argon prior to ignition to provide
10 non-toxic reaction products in the exhaust gas.

2. The method of claim 1 wherein the non-toxic
reaction products in the exhaust gas are selected from
the group consisting of CO₂, H₂O, N₂ and mixtures thereof.

3. The method of claim 1 wherein the selected
15 mixture of molecular oxygen-containing gas with argon
enables the oxidation level of the propellant composition
to be controlled and fall into a desired range.

4. The method of claim 1 wherein the binder is
selected from the group consisting of HTPB, polyvinyl
20 alcohol and a polycarbonate.

5. The method of claim 1 wherein the binder is
polycarbonate and the propellant composition is in the
form of a pressed pellet charge.

6. The method of claim 5 wherein the binder
25 comprises about 5% by weight of the propellant.

7. The method of claim 6 wherein the ignition
environment comprises about 21 parts by volume of oxygen
and about 79 parts by volume of argon.

8. The method of claim 6 wherein the ignition environment comprises about 15 to about 30 parts by volume of oxygen with a complementary volume of argon.

5 9. The method of claim 1 wherein the binder is HTPB and the propellant composition is in the form of a cast, injection molded or extruded mass.

10. The method of claim 9 wherein the propellant composition also includes a curing agent.

10 11. The method of claim 4 wherein the propellant composition comprises about 95% by weight aminoguanidine nitrate and the charge is non-hygroscopic.

12. The method of claim 1 wherein the generated gases are used to inflate an automotive vehicle air bag.

15 13. The method of claim 11 wherein the generated gases are used to inflate an automotive vehicle air bag.

20 14. In a method for generating gas to fill an automotive vehicle air bag utilizing a combination of air and argon as the environment in which compounds constituting the primary source of gas are burned to generate said gas to inflate said air bag, the improvement comprising utilizing a propellant composition comprising aminoguanidine nitrate, in conjunction with a suitable binder, as said primary source; and employing during ignition, ratios of air to argon whereby
25 particulates and toxic amounts of nitrogen oxides, ammonia, HCN, and nitric acid in the exhaust are minimized.

15. The improvement of claim 14 wherein the non-toxic products in the exhaust gas are selected from the group consisting of CO₂, H₂O, N₂ and mixtures thereof.

5 16. The improvement of claim 14 wherein the propellant composition is used with a binder of hydroxy-terminated polybutadiene.

17. The improvement of claim 14 wherein the binder is a polycarbonate.

10 18. The improvement of claim 14 wherein the propellant composition includes a polycarbonate binder.

19. The improvement of claim 18 wherein the propellant composition includes 5% by weight polycarbonate binder.

15 20. The improvement of claim 19 wherein the propellant composition includes aminoguanidine nitrate and the propellant composition and binder are in the form of a pressed pellet charge.

21. The improvement of claim 16 wherein a curing agent is included with the binder.

20 22. The method of claim 1 wherein the binder is polyvinyl alcohol.

25 23. The method of claim 1 wherein the propellant composition comprises about 95% by weight aminoguanidine nitrate and about 5% by weight polyvinyl alcohol as binder, said composition being ignited in the presence of 20% oxygen and 80% argon.

24. The improvement of claim 14 wherein the compound constituting the primary source of gas is AGN and a polyvinyl alcohol is used as binder.

5 25. The improvement of claim 24 wherein the polyvinyl alcohol is present in an amount of 5% by weight.

26. The improvement of claim 20 wherein the binder is polyvinyl alcohol.

10 27. The improvement of claim 26, wherein the polyvinyl alcohol binder is present in the amount of 5% by weight of the propellant composition.

28. The improvement of claim 21, wherein the curing agent is IPDI.

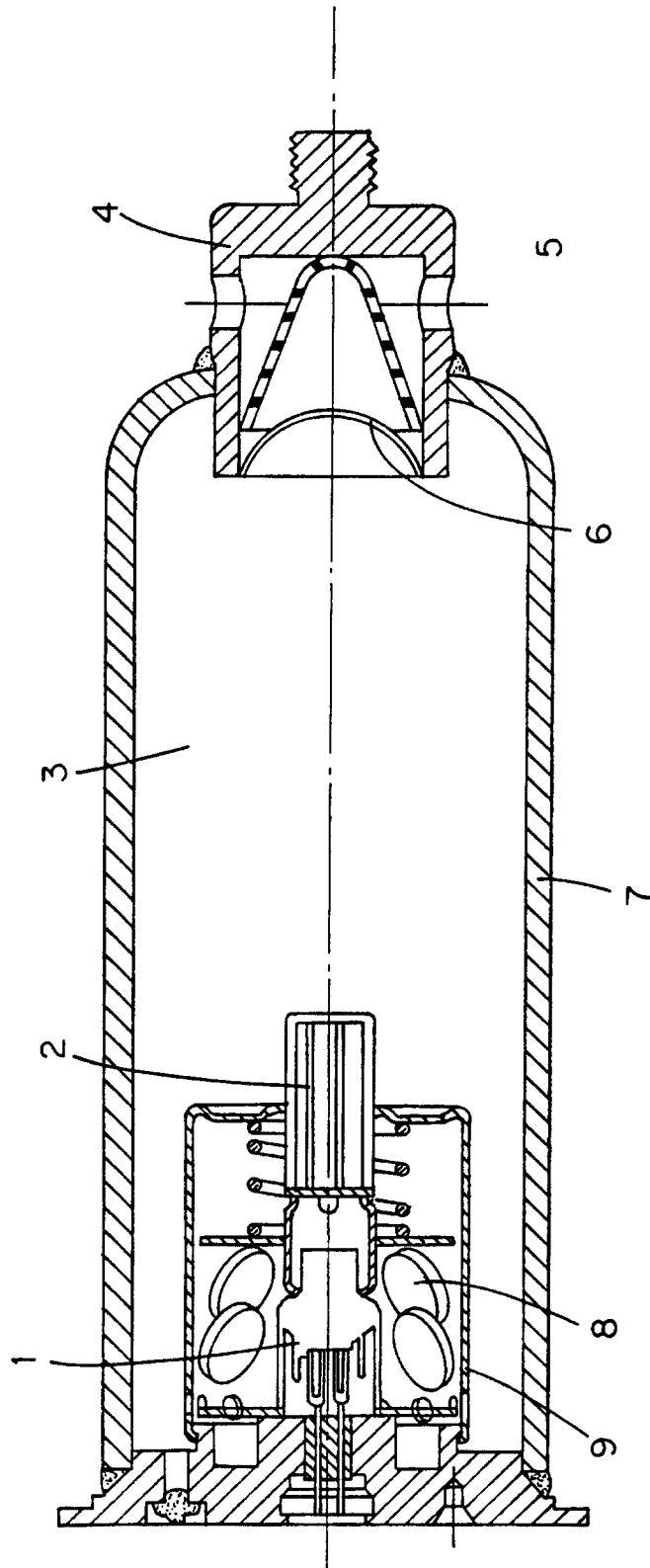

PASSENGER SIDE INFLATOR

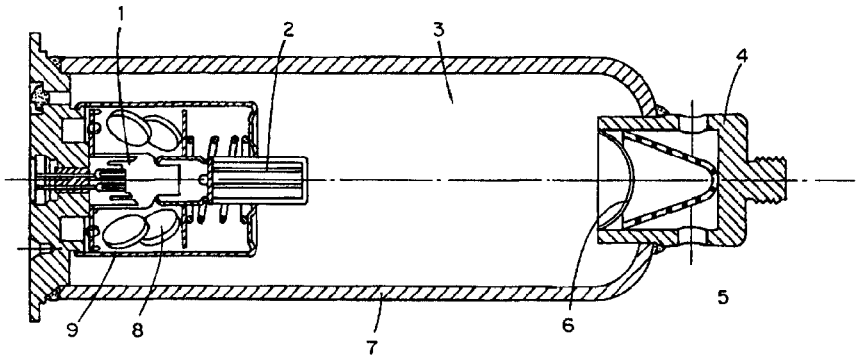

PASSENGER SIDE INFLATOR