

[54] **BOOK TRIMMING MACHINE**  
 [75] Inventors: **James F. Cosgrove**, Western Springs; **William E. Soong**, Westmont, both of Ill.  
 [73] Assignee: **McCain Mfg. Corporation**, Chicago, Ill.  
 [22] Filed: **July 30, 1973**  
 [21] Appl. No.: **383,881**  
 [52] U.S. Cl. .... **83/89, 83/27, 83/91, 83/255, 83/925 A**  
 [51] Int. Cl. .... **B26d 7/06**  
 [58] Field of Search ..... 83/27, 88, 91, 255, 78, 83/925 A, 89, 111, 109, 112

3,207,017 9/1965 McCain ..... 83/27  
 3,693,486 9/1972 Maniaci ..... 83/88

Primary Examiner—Donald R. Schran  
 Attorney, Agent, or Firm—Kinzer, Plyer, Dorn & McEachran

[57] **ABSTRACT**

Book trimming machine wherein two identical books are joined head to foot by a separation margin. The books are severed by one knife cutting along one line of the separation margin, leaving the margin on one of the books which is subsequently severed by a second knife. A book transport clamps one of the books severed by the first knife and feeds it along a path divergent from the remaining book to afford ample room for handling the separation margin severed by the second knife.

[56] **References Cited**  
**UNITED STATES PATENTS**  
 2,562,938 8/1951 Moyer ..... 83/255

**6 Claims, 7 Drawing Figures**

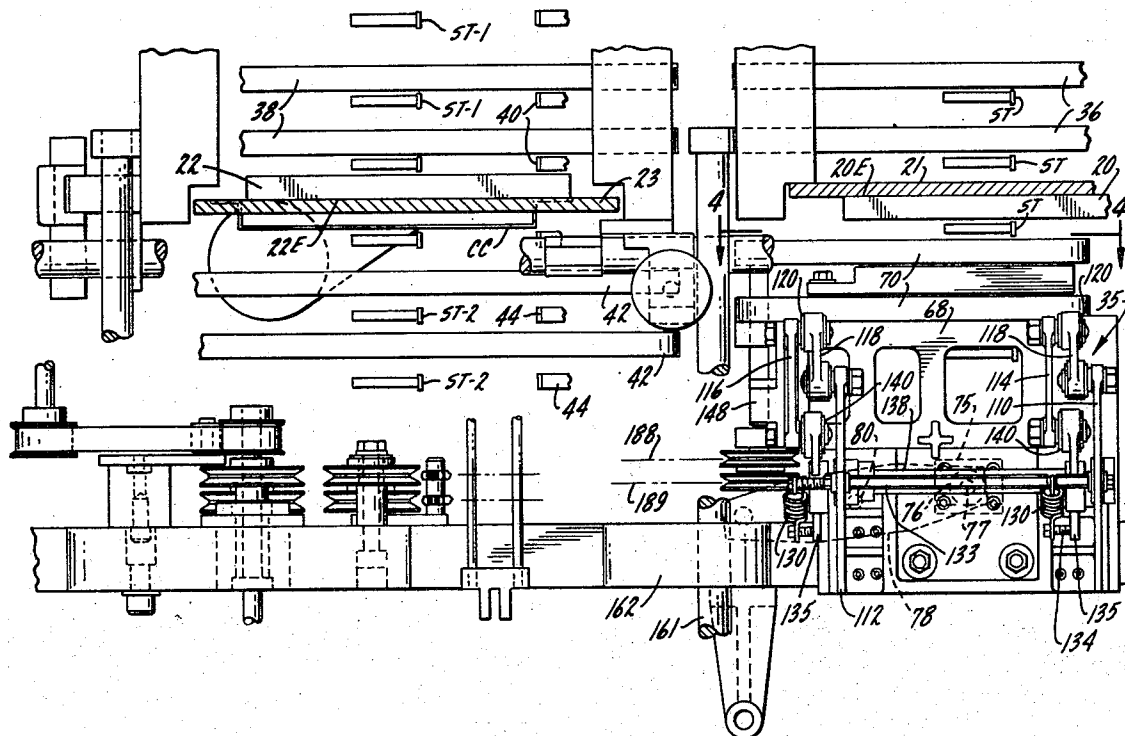

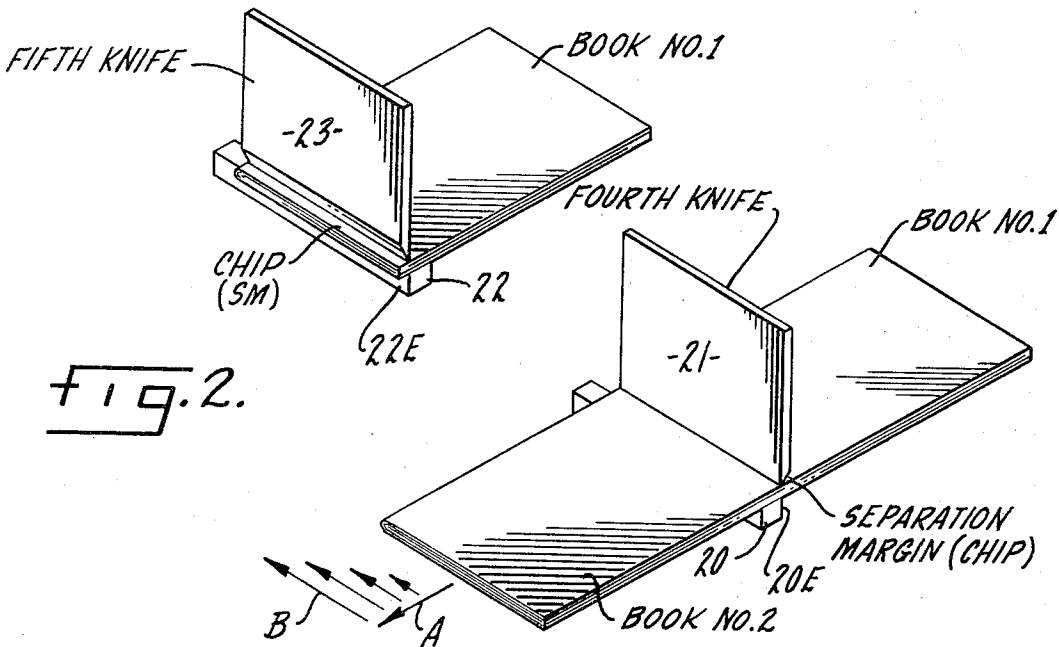
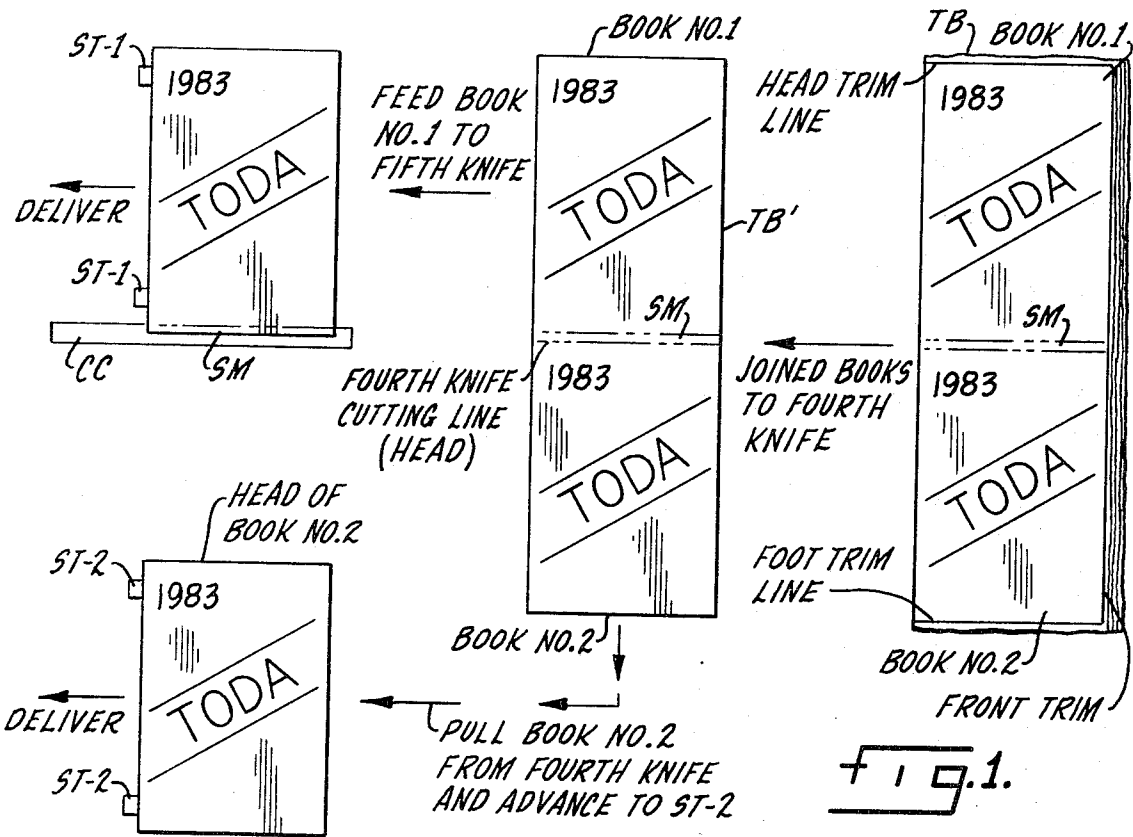

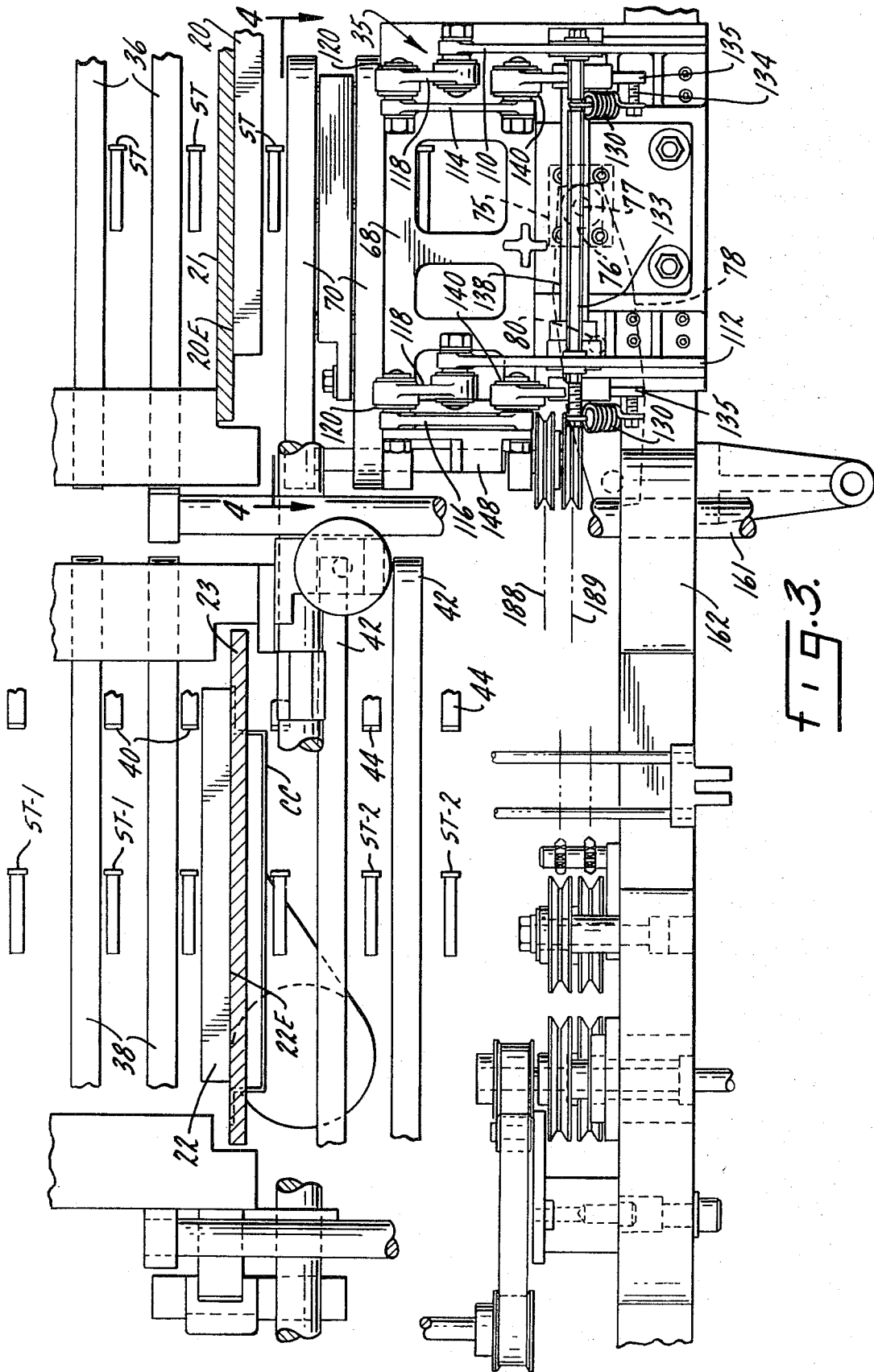

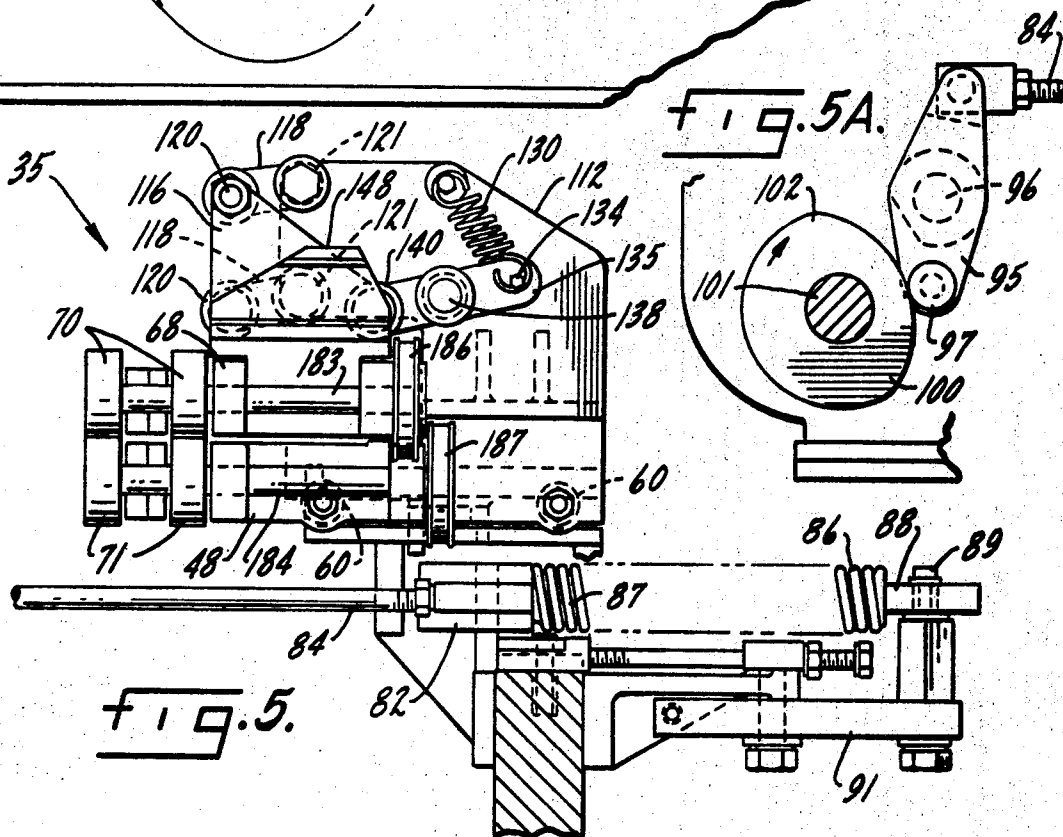
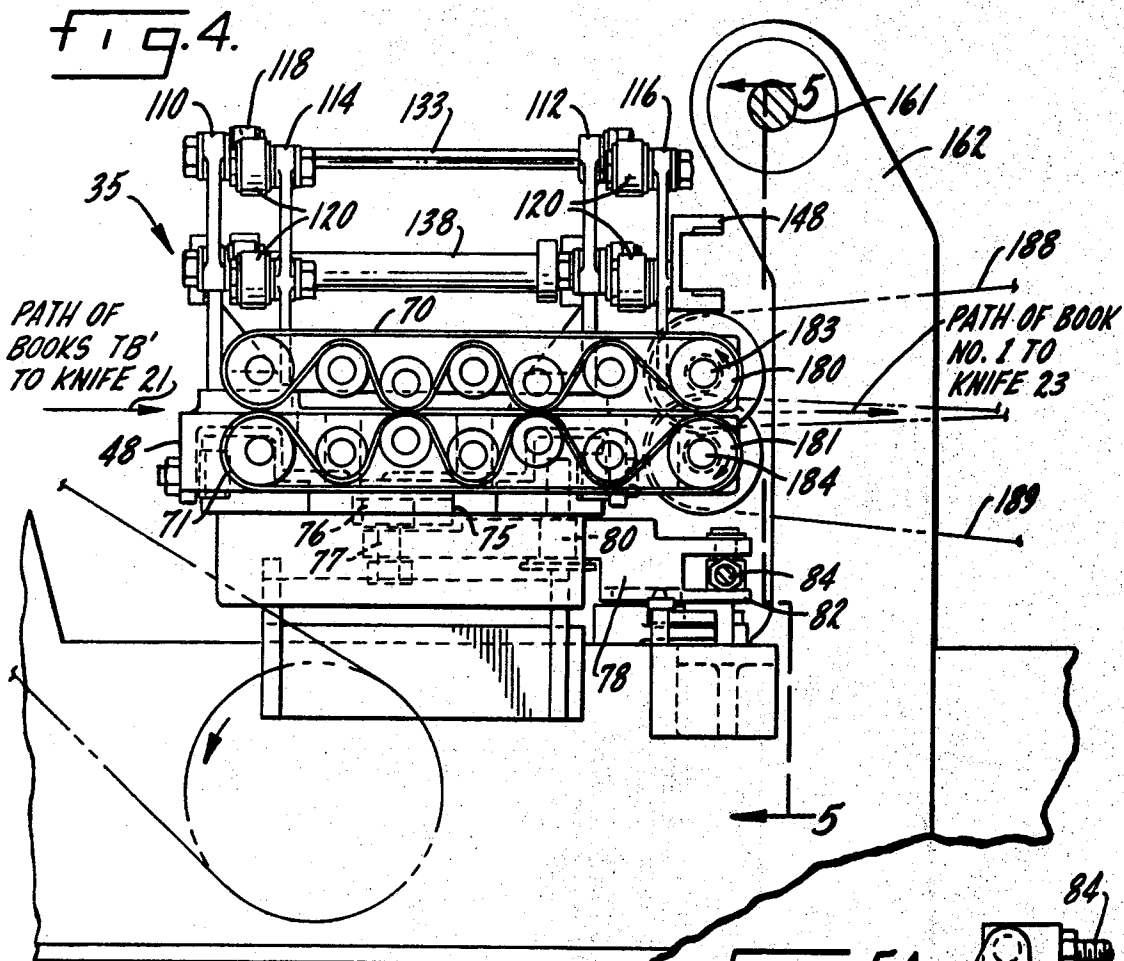

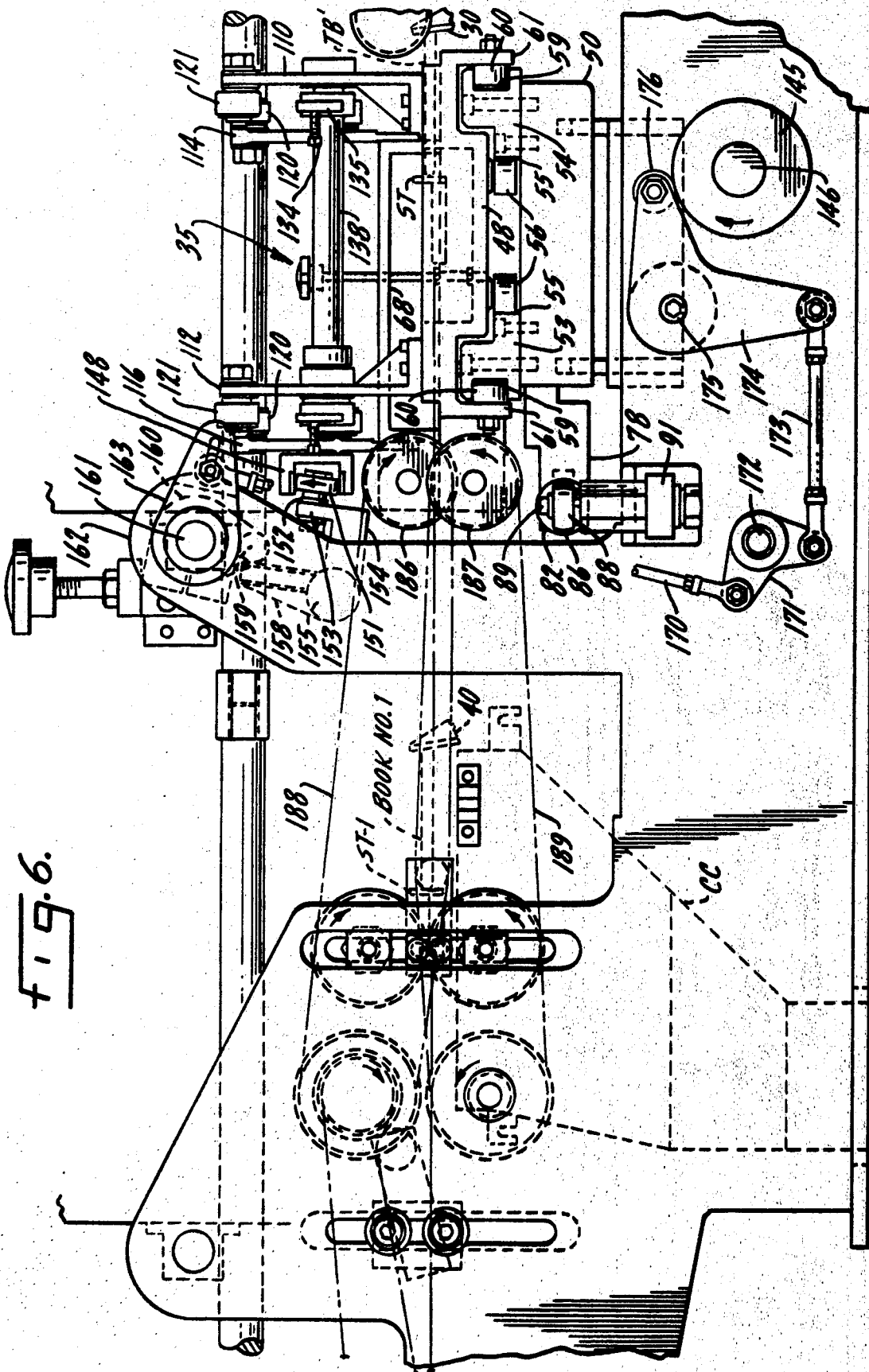

## BOOK TRIMMING MACHINE

This invention relates to a machine for trimming books.

Certain kinds of books are printed in double or twin form, particularly in the instance of small books such as pamphlets, newspaper supplements, news guides, stamp saver books and the like. In this instance two books are joined at the head and foot, separated by a margin of small width. The ragged edges are trimmed at the head, foot and front by three knives. Afterwards, the books are severed by a fourth knife, leaving the aforesaid margin on one of the books which is subsequently separated as a waste paper "chip." Thus, a fourth knife separates one of the book twins, producing a final head or foot cut at the same time, and the remaining book is transported to a fifth knife station where the chip is removed.

The chip, as noted, constitutes waste paper shreds which, if not properly handled, can interfere with book travel and in many instances can interfere with proper machine operation.

The primary object of the present invention is to enable the chip to be more effectively handled than heretofore by separating the books in a unique fashion after the fourth knife had made its cut. More specifically in this regard, an object of the present invention is to devise a shuttle or book transport device which picks up one of the books separated by the fourth knife and delivers it to a conveyor sufficiently separated (diverted) from the fifth knife to enable the chip to be produced without interfering with book delivery.

The separated books are to be individually delivered to a collection station. For many different reasons, accurate counting, for example, it is advantageous that the two books be delivered simultaneously to the collecting station. Inasmuch as the books are separated by the fourth knife and follow separate paths, it is a further object of the present invention to be able to assure that the two books will arrive simultaneously at the collecting station.

Other and further objects of the present invention will be apparent from the following description and claims and are illustrated in the accompanying drawings which, by way of illustration, show a preferred embodiment of the present invention and the principal thereof and what we now consider to be the best mode in which we have contemplated applying that principle. Other embodiments of the invention embodying the same or equivalent principle may be used and structural changes may be made as desired by those skilled in the art without departing from the present invention.

In the drawing:

FIG. 1 is a diagrammatic view showing movement of books under the present invention;

FIG. 2 is a schematic view showing the trimming of the books by the fourth and fifth knives;

FIG. 3 is a plan view of a book-trimming machine incorporating the features of the present invention;

FIG. 4 is a partial side elevation of the machine shown in FIG. 3, taken substantially on the line 4-4 of FIG. 3;

FIG. 5 is an end elevation taken substantially on the line 5-5 of FIG. 4;

FIG. 5A is a detail view of means controlling reciprocation of the transport device; and

FIG. 6 is a front elevation of the machine shown in FIG. 3.

## GENERAL DESCRIPTION

FIG. 1 is a flow chart showing progressive trimming and separation operations which occur in the course of trimming and separating two books, No. 1 and No. 2, which initially are presented as Siamese twins, joined by a separation margin SM located medially between the books. The first operation is standard and constitutes no part of the present invention: the head, foot and front of the twin book TB received from the printer, are ragged and are trimmed by three knives, not shown, which respectively cut along the Head Trim Line, the Foot Trim Line, and the Side Trim Line. The result is a twin book assembly TB', FIG. 1, comprising book No. 1 and book No. 2 still joined by the medially located separation margin SM.

The twin books are delivered to a fourth knife which cuts along one line of the margin SM, the Fourth Knife Cutting Line; book No. 2 has thus received its last cut and is separated from book No. 1 as will be described in detail below. More specifically, Book No. 2 is pulled from the fourth knife and at the same time is fed forwardly in a unique fashion; in the meantime, book No. 1, containing the separation margin SM is fed or delivered to the fifth knife which makes the final cut along the Fifth Knife Cutting Line.

The margin SM is thus separated from book No. 1 as a "chip" or collective waste part of as many pieces as there are pages in the book. The chip thus produced drops into a chip chute CC where suction or negative pressure prevails, assuring that the chip is effectively withdrawn.

As shown in FIG. 1, book No. 2 is advanced from the fourth knife station to stops ST-2. Similarly, book No. 1 is advanced to stops ST-1, at the fifth knife station. After the fifth knife has made its cut, the stops for both books are withdrawn, and the two books are delivered simultaneously to respective stackers, which are not part of the present invention. Significant in this connection, however, is the fact that when books as book No. 1 and book No. 2 move along separate paths for delivery to separate stackers, they are customarily counted on arrival at the stacker, and when a predetermined number in each stack is collected, the two stacks of equal number are then moved automatically to a common conveyor incidental to collection for mailing or other form of distribution.

Referring to FIG. 2, a bottom knife 20 presents a shearing edge 20E opposed to the fourth knife 21 and a bottom knife 22 presents a shearing edge 22E opposed to the fifth knife 23. These edges are also shown in FIG. 3. It will be recognized from FIG. 2 that the separation margin is the part that will be crushed or wrinkled in the course of separating book No. 2 from book No. 1, and also in the course of separating the chip from book No. 1. In other words, the bevel or sloped side of each knife wedges and pushes against the separation margin. This is as it should be, since the waste product, the chip, is the part being crushed or compressed by the knife, not the head or foot of the book.

However, as can be seen from FIG. 3, the knife edges 20E and 22E are separated by little lateral distance. Space is a premium, but nevertheless, the chip, FIG. 1, must be effectively disposed of without fouling the ma-

chine. Under the present invention, space for handling the chip effectively is achieved by pulling book No. 1 away from the fourth knife after the fourth knife has made its cut, and by this method, ample space is made available for the chip chute CC, FIGS. 1 and 3, so that there will be little interference between the severed chip and the head of book No. 2.

In FIG. 1, with the two books against their respective stops, there is an exaggerated distance between the foot of book No. 1 and the head of book No. 2. In the actual circumstances, under the conditions to be described below, the separation is about one inch (2.54 cm) but this separation represents ample clearance for effectively ejecting the separated chip into the chute CC, assuring lack of interference between the head of book No. 2 and the separated chip.

Whatever examples may be appropriate to explain the problem of coping with the chip or separation between the books, and coping with the problem of being able to deliver the two books for concurrent advance from the stops, FIG. 1, after the fifth knife has made its cut, the present invention affords an answer to both problems.

The answer is to so transport book No. 2, FIG. 2, away from the fourth knife (in the direction of arrow A, FIG. 2) which leaves clearance for the chip next to be separated by the fifth knife, while concurrently feeding book No. 2 (in the direction of arrow B, FIG. 2) toward its stops at the same rate book No. 1 is being delivered to its stops so that both books arrive at the stops at the same time consistent with the proposition that after the fifth knife has made its cut, both books are to be moved at the same rate to the delivery position.

The detailed description to follow takes no account of the manner in which the twin book TB, FIG. 1, is trimmed at the head, foot and side, since this is a standard operation employing three knives; nor is the description to follow concerned with the form or operation of the stops or with the manner of transporting the books from the stop at the same rate, since this is accomplished by standard feed tapes. Thus, the present invention is concerned with the manner in which book No. 2 is transported to the stops ST-2.

#### DETAILED DESCRIPTION

The book pair TB', FIG. 1, as already noted, has received a head trim, a foot trim and a front trim. The remaining operation, so far as trimming is concerned, is to apply the fourth knife to sever the books and then to apply the fifth knife to sever the chip from book No. 1. To this end, the joined books TB', FIG. 3, are advanced to what may be designated the first knife station where knife 21, FIG. 3, cuts along the marginal line corresponding to the head of the book No. 2.

The double book TB' is fed to the first knife station by pusher fingers as 30, FIG. 6 and the book is accurately located at the first knife station by vertically movable stops ST, FIG. 3. Operation of the pusher fingers as 30 and the stops ST is known and consequently it need only be mentioned that the pusher fingers 30 and stops ST are operable in each cycle of the machine to feed the joined book pair TB' into the first knife station, locating the books and stopping the books momentarily to enable the severance operation to be performed by knife 21.

After knife 21 has severed the books, a book transport or shuttle device 35, FIG. 3, is effective to clamp

one of the severed books, withdrawing that book away from knife 21 along a path at right angles to the cutting stroke of knife 21 while concurrently feeding that book out of the first knife station toward its stops as ST-2. Details of the book transport 35 will be described in detail below, but first it will be mentioned that the book containing the separation margin, FIG. 2, is fed out of the first knife station after the stops ST are lowered, by feed tapes 36, FIG. 3, which are aligned with feed tapes 38 associated with the second knife station where knife 23 is located. The book having the separation margin to be severed is positioned against stops ST-1, FIG. 3, and again pusher fingers as 40 are utilized to assure that the backbone (folded side) of book No. 1 is accurately presented to the stops ST-1 before knife 23 commences its cutting stroke.

In the meantime, while book No. 1 is being advanced to the stops ST-1, the transport device 35 is in the process of delivering book No. 2 to a set of feed tapes 42 which are effective to advance book No. 2 to the stops ST-2 which are aligned with stops ST-1. Again, pusher fingers as 44 are utilized to align book with the stops ST-2.

From this it will be seen that one of the books severed by knife 21 at the first knife station (book No. 1) is moved out of the first knife station along a path coaxial with its path into the first knife station. The other book severed by knife 21 (book No. 2) is fed out of the first knife station along a path which diverges from the entry path into the first knife station. One mode of attaining this divergence will now be explained in detail.

The transport or shuttle apparatus 35 is guided for reciprocal movement at right angles to the cutting line of knife 21. Thus the book transport 35, FIG. 6, incorporates a base 48 supported for reciprocal movement on a fixed bed 50 in the machine. The bed 50 is provided with a pair of fixed side rail members 53 and 54 presenting opposed vertical track surfaces 55 along which travel a pair of guide rollers 56 rotatably mounted at the underside of the base 48 of the transport 35. The opposed exterior faces of the rail members 53 and 54 are provided with recessed tracks 59 which serve as guides for rollers 60 rotatably mounted on dependent legs 61 at the opposed sides of the base 48.

The transport 35 incorporates means to both clamp book No. 2, severed by knife 21, and feed it out of the first knife station. Advantageously, the clamping means and feeding means are unified. To this end, the transport 35 includes a pair of clamping elements in the form of a pair of jaws. In the present instance base member 48 constitutes a fixed lower jaw which is opposed to an upper, vertically moveable jaw 68, FIG. 5, the two jaws in turn supporting opposed feed tapes 71 and 70 respectively, FIGS. 4 and 5.

As noted above, the transport 35 is guided for reciprocation toward and away from knife 21 along a path at right angles to the cutting edge of knife 21. The advance position of transport 35, nearest knife 21, is shown in FIG. 5, and at this time the feed tapes 70 and 71 are in an attitude of minimum clearance which is to say that book No. 2 separated from book No. 1, may be clamped therebetween.

The description to follow will be concerned first with the manner in which the transport 35 is reciprocated and then will be concerned with the means by which the upper jaw 68 may be lowered in the advanced posi-

tion of the transport to clamp a book, and raised in a retracted position of the transport to release the book to feed tapes 42.

#### RECIPROCATION OF THE TRANSPORT

The machine is cyclically operated in the sense of repeatedly feeding to knife 21 the joined books to be severed and repeatedly delivering the severed books from the first knife station in the direction of stops ST-1 and ST-2. A cycle of the machine may be viewed also as represented by the stroke of a knife as 21 or 23, from top dead center to bottom dead center, and return.

The transport 35 is cyclically operated, repeatedly to clamp a book as book No. 2, withdrawing it from the first knife station, delivering the clamped book to tapes 42 and returning to the first knife station to clamp the next book severed at the first knife station. To this end, a cyclically operated cam means is used to control and impart reciprocal movement to transport 35, and in this connection attention is directed to FIGS. 4, 5 and 5A.

The base plate 48 is provided at the underside with a lug 75, FIG. 4, presenting a fixed track which embraces a roller 76. Roller 76 is journaled on a vertical stub shaft 77 which in turn is supported by an operating lever 78 such that by oscillating lever 78, FIG. 3, the transport unit 35 is advanced to or retracted from the first knife station as the case may be.

As shown in FIG. 4, lever 78, at an intermediate position, is pivotally mounted on a fixed bushing 80. The end of lever 78 opposite roller 76 is provided with a bifurcation arm 82 pinned to a rod 84.

Rod 84 is spring biased so that transport 35 is normally in a retracted position relative to the first knife station. A cyclically operated cam is effective to drive rod 84 in opposition to the spring bias advancing the transport unit to the first knife station. The manner in which this is accomplished will now be described.

Thus, a compression spring 86, FIG. 5, at one end is mounted on a guide element 87 fastened to and coaxial with rod 84 and the opposite end of the spring 86 bears against a guide lug 88 pivotally mounted on a pin 89 in turn mounted on a fixed horizontal arm 91 to extend upwardly therefrom. The opposite end of spring 86 bears against the bifurcated end 82 of lever 78 as shown in FIG. 5, tending thereby to urge lever 78 clockwise as viewed in FIG. 3 to retract the transport 35 from the first knife station.

The end of rod 84 opposite spring 86 is pivotally connected to the upper end of a lever 95, FIG. 5A, the latter having a fixed pivot 96. The lower end of arm 95 has a cam follower 97 journaled thereon, cam follower 97 engaging the periphery of a cam 100 secured to a constantly driven drive shaft 101 so that cam 100 continuously rotates cyclically to operate lever 95 and the rod 84 connected thereto.

The dwell or low part of cam 100, FIG. 5A, is shown as presented to the cam follower 97, and at this time spring 86 is extended, disposing the transport 35 in its rearwardmost or retracted position relative to the first knife station. On the other hand, when the lobe 102 or high part of cam 100 is presented to cam follower 97, arm 95, FIG. 5A, is oscillated counterclockwise.

#### OPERATION OF THE TRANSPORT AND FEED MEANS

Referring to FIG. 6 a pair of vertically extending sup-

port plates 110 and 112 are fixed to the upper surface of the base plate 48; the moveable jaw 68 is supported in and articulated relative therein for up and down movement. To this end, a pair of side plates 114 and 116, FIGS. 3 and 6, are joined to and extend upwardly from the side surfaces of the upper jaw or clamp 68. Each side plate, as best shown in FIG. 5, is provided with a pair of links as 118 which assure that the upper jaw 68, during its vertical movement, travels along a fixed and predetermined path, the links 118 at one end being journaled on bushings 120, mounted on the side plates 114 and 116 with the opposite ends of the links 118 being journaled on bushings 121, mounted on the side plates 112 and 114.

The upper jaw 68 is spring-tensioned whereby the clamp and feed belts 70 and 71, FIG. 5, are normally at minimum clearance thereby to clamp a book. Accordingly, the upper ends of a pair of springs 130, FIGS. 3 and 5, are anchored to a tie rod 133 having the ends thereof fastened to the support plates 110 and 112.

The lower end of each spring 130 is secured to a pin as 134, FIG. 5, presented at one end of an operating arm 135. Each operating arm 135, intermediate its ends, is supported pivotally on a spacer rod 138, FIG. 3, extending between and secured to the support plates 112 and 114.

The end of each arm 135 opposite the anchor pin for spring 130 is pivotally connected to a bushing 140, FIG. 3, carried by the side plates 114 and 116 associated with the moveable jaw 68. As will be evident from FIG. 5, the springs as 130 tend to oscillate the arms 135 counterclockwise, presenting the upper jaw 68 to the lower jaw 48 and more specifically presenting the feed belts 70 (representing the upper jaw) to the feed belt 71 representing the lower jaw or clamp.

The upper jaw 68 is elevated against the normal return action of the springs 130 by a cyclically operated cam 145, FIG. 6, cam 145 being carried on a constantly driven shaft 146.

A track element 148, FIGS. 5 and 6, is fastened to the side plate 116 of the upper jaw. The track 148, as shown in FIG. 6, presents a pair of spaced lugs between which is disposed a roller 151. Roller 151 is journaled on a pin 152 carried by one arm 153 of a bell crank 154, pivotally mounted at 155 on a support, not shown.

The other arm 158 of the bell crank 154 engages a roller 159 carried at the lower end of an arm 160, secured to a rock shaft 161 supported rotatably in a post 162. Another arm 163 is secured to the rock shaft 161, extending outwardly therefrom. An operating rod 170, FIG. 6, has the upper end thereof connected to arm 163 and the lower end is connected to one arm of a bell crank 171 supported pivotally at 172. A link 173 is connected to the other arm of bell crank 171.

One arm of a bell crank 174 is pivotally supported at 175, and connected to link 173, and the opposite arm of the bell crank 174 carries a follower 176 which engages cam 145. From this it will be seen that when the lobe or high part of cam 145 is presented to follower 176, jaw 68 will be raised against the return action of the springs 130. Conversely, when the dwell or low part of cam 145 is presented to follower 176 the springs 130 are effective to engage the feed tapes 70 and 71.

The transport 35, FIG. 3, is shown at its innermost position, that is, the advanced position nearest knife

21, which is also the position shown in FIG. 5 where the belts 70 and 71 are engaged one with another, which is to say that the book No. 2, completely trimmed, head, foot, and front, may be clamped by the belts 70 and 71, recognizing that the timing is such that the jaws 68 and 48 are open as the transport 35 moves inward toward knife 21 to embrace the severed book, cam 145 presenting its lobe to follower 176 at this time. When the open jaws 48 and 68 attain the innermost, advanced position, the dwell of cam 145 is presented to the follower 176 whereby the feed belts 70 and 71 clamp the upper and lower surfaces of book No. 2. Transport 35 is then retracted by spring 86, FIG. 5, the dwell of cam 100 being presented to follower 97.

During retraction or withdrawal of transport 35, the feed belts 70 and 71, driven as hereinafter described, continuously advance book No. 2 in the direction of arrows B, FIG. 2, feeding the withdrawn book in the direction of tapes 42, FIG. 3. Thus, as the severed book is withdrawn from the first knife station at right angles to the cutting stroke of knife 21 (path A, FIG. 2) the withdrawn book is, at the same time, translated along a feed path which parallels the entry path of the book assembly into the first knife station.

When feed tapes 70-71 are aligned with feed tapes 42, the jaw 48 and 68 are opened (cam 145 presents its lobe to follower 176) releasing the withdrawn book to tapes 42 which advance book No. 2 to the stops ST-2. Accurate alignment of the backbone or folded side of book No. 2, relative to the stops ST-2 is assured by the pusher fingers 44.

In the meantime the stops ST are lowered as knife 21 clears cutting edge 20E during the upper stroke of knife 21, whereupon feed tapes 36 deliver book No. 1 to the stops ST-1, the feed path of book No. 1 being colinear or co-axial with its entry path into the first knife station.

Book No. 1 and book No. 2 arrive at their respective stops ST-1 and ST-2 substantially simultaneously, and knife 23 then makes its cut to separate the marginal chip SM, FIG. 2, the chip dropping into the discharge chute CC. After knife 23 has made its cut, stops ST-1 and ST-2 are lowered and the two books are advanced out of the fifth knife station by their respective feed tapes 38 and 42 in accordance with the objective of the invention mentioned above.

The feed tapes 70 and 71 are trained around driven pulleys 180 and 181, FIG. 4. These pulleys are mounted on driven shafts 183 and 184, FIG. 5, driven by pulleys 186 and 187 in turn operated by drive belts 188 and 189, FIG. 3.

#### SUMMARY

It will be seen from the foregoing that the joined books are fed to the first knife station (knife 21) along a predetermined path which may be taken as colinear with knife edge 20E. After knife 21 makes its cut, one of the severed books is fed out of the first knife station along the same path but the other severed book is diverted in accordance with the object mentioned above which is to afford ample room for handling the chip produced by knife 23. Under the mode of practice disclosed, book No. 2 is the one diverted by the transport apparatus 35 and book No. 1 is the one which retains the separation margin SM to be severed at the second knife station. However, the arrangement could be modified in that book No. 1, retaining the separation mar-

gin SM, is the book to be diverted, which assumes a further modification in that knife 23 would be displaced accordingly in the direction of the feed tapes 38, FIG. 3, perhaps feasible in some machines.

Both books, in any event, are advantageously fed out of the first knife station at the same rate so that the stops ST-1 and ST-2 may be raised and lowered in unison, both books being halted momentarily while knife 23 makes its cut, completing the final trim of the book presented thereto. Consequently, when the stops ST-1 and ST-2 are lowered, both books may be fed from the second knife station at the same rate to arrive simultaneously at the collecting station.

Various modifications may be made in the actual construction, especially in terms of the cyclically operable means which reciprocate the transport and operate the moveable jaw thereof. Under the present disclosure, cams are used but eccentrics could be used as well, in fact, any mechanical arrangement which translates rotary motion into lineal motion.

Hence, while a preferred embodiment of the invention and the principle thereof have been set forth in detail, it is to be understood that various changes and modifications may be made by those skilled in the art.

#### We claim:

1. A cyclically operable book trimming machine for severing two books joined head to foot by a medially located separation margin and comprising: first and second knives at respective first and second knife stations, said first knife making a cut along one line of the separation margin to sever the books, said second knife severing the separation margin as waste paper, means to collect the waste paper, means to feed the joined books along a predetermined path to the first knife, means to feed one of the severed books out of the first knife station along a path co-linear with said predetermined path, a reciprocal book transport for clamping the other book and feeding it out of the first knife station along a path divergent from the first-named path, and cyclically operable means for reciprocating the book transport into and out of the first knife station during repeated cycles of the machine repeatedly to clamp and feed books severed by the first knife.

2. A machine according to claim 1 wherein the transport includes a fixed jaw and a vertically moveable jaw presenting feed means which both clamp said other book and feed the other book out of the first knife station.

3. A machine according to claim 1 including a first set of stop means at the second knife station against which is positioned the severed book having the margin to be severed, and a second set of stop means against which is positioned the other book fed from the first knife station, and said first and second sets of stop means being aligned.

4. A machine according to claim 3 wherein the transport includes a fixed jaw and a vertically moveable jaw presenting opposed upper and lower feed tapes which both clamp the other book severed by the first knife and feed said other book out of the first knife station toward said second set of stops.

5. A machine according to claim 4 wherein reciprocal movement of the book transport and movement of the moveable jaw are under control of a pair of cyclically operable cams.

6. A cyclically operable book trimming machine for severing two books joined head to foot by a medially located separation margin and comprising: first and second knives at respective first and second knife stations, said first knife making a cut along one line of the separation margin to sever the books, said second knife severing the separation margin as waste paper, means to collect the waste paper, means to feed the joined books along a predetermined path to the first knife, means to feed one of the severed books out of the first knife station to a first set of stops and along a path co-linear with said predetermined path, a reciprocal book transport moveable along a path at right angles to said

predetermined path, said transport having feed tapes for embracing and clamping the upper and lower surfaces of the other book severed by the first knife, means on said book transport to drive the tapes to feed the clamped book out of the first knife station, and cyclically operable means for reciprocating the book transport into and out of the first knife station and for presenting the feed tapes in clamping relation to said other book during repeated cycles of the machine repeatedly to clamp and feed books severed by the first knife.

\* \* \* \* \*

15

20

25

30

35

40

45

50

55

60

65