

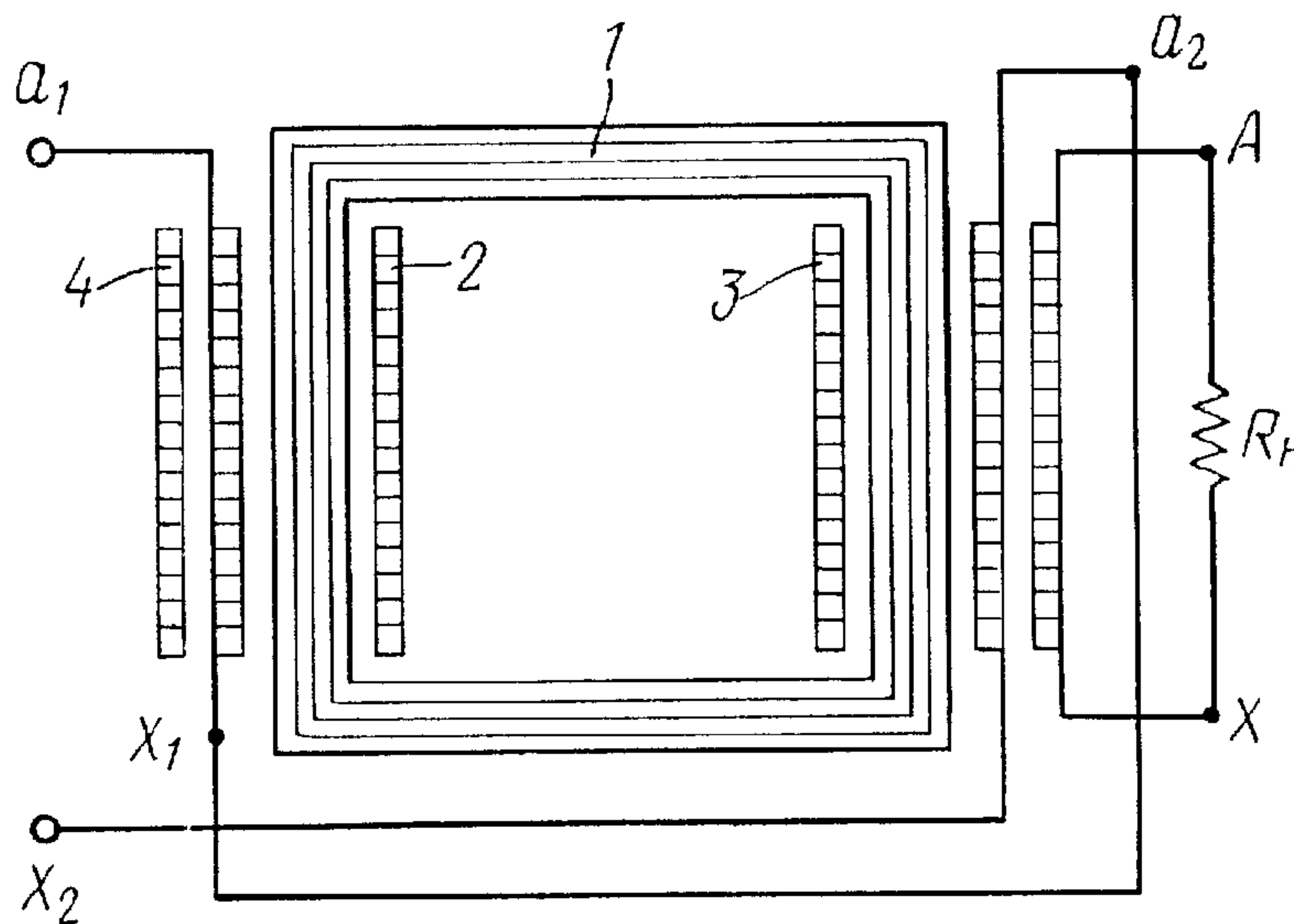

(86) Date de dépôt PCT/PCT Filing Date: 1997/04/10
 (87) Date publication PCT/PCT Publication Date: 1997/10/23
 (45) Date de délivrance/Issue Date: 2006/01/24
 (85) Entrée phase nationale/National Entry: 1997/12/15
 (86) N° demande PCT/PCT Application No.: RU 1997/000110
 (87) N° publication PCT/PCT Publication No.: 1997/039463
 (30) Priorités/Priorities: 1996/04/16 (96106791) RU;
 1997/02/05 (97101702) RU

(51) Cl.Int.⁷/Int.Cl.⁷ H01F 30/06, H01F 27/28
 (72) Inventeur/Inventor:
 MARKOV, GENNADY ALEXANDROVICH, RU
 (73) Propriétaire/Owner:
 MARKOV, GENNADY ALEXANDROVICH, RU
 (74) Agent: OGILVY RENAULT LLP/S.E.N.C.R.L.,S.R.L.

(54) Titre : TRANSFORMATEUR
 (54) Title: TRANSFORMER



(57) Abrégé/Abstract:

Several types of transformers are proposed which may be used as the main electrical engineering equipment of electric power stations, substations, power lines, in radio engineering, in devices for measuring, automatic control and regulation. At the basis of the invention lies the principle under which the primary winding consists of two sections wound and connected to each other in such a way that the magnetic flux created by one of such sections during operation of the transformer compensates the magnetic flux created by the other section of the primary winding. The transformer comprises (Fig. 2) a magnetic circuit, a primary winding consisting of two sections wound in one direction on a core of the magnetic circuit and having an identical number of turns. The windings of the two sections are connected to each other by their outs, while the ins of the windings serve as inlets for the power supply. The secondary winding is wound on the primary winding on the same core of the magnetic circuit, a load R_H is connected to the secondary winding. The developed embodiments of the transformer are distinctive in that the sections of the primary winding are wound on one core of the magnetic circuit (3 embodiments) or on two cores of one magnetic circuit (4 embodiments), in that the direction in which the sections of the winding are wound is different (in one or opposing directions), and consequently there is a different connection of the windings, and are also distinguished by the presence of a secondary winding (in one embodiment there is no secondary winding).

TRANSFORMER ABSTRACT

Several types of transformers are proposed which may be used as the
5 main electrical engineering equipment of electric power stations, substations,
power lines, in radio engineering, in devices for measuring, automatic control
and regulation. At the basis of the invention lies the principle under which the
primary winding consists of two sections wound and connected to each other
10 in such a way that the magnetic flux created by one of such sections during
operation of the transformer compensates the magnetic flux created by the
other section of the primary winding.

The transformer comprises (Fig. 2) a magnetic circuit, a primary
winding consisting of two sections wound in one direction on a core of the
magnetic circuit and having an identical number of turns. The windings of the
15 two sections are connected to each other by their outs, while the ins of the
windings serve as inlets for the power supply. The secondary winding is wound
on the primary winding on the same core of the magnetic circuit, a load R_H is
connected to the secondary winding.

The developed embodiments of the transformer are distinctive in that the
20 sections of the primary winding are wound on one core of the magnetic circuit
(3 embodiments) or on two cores of one magnetic circuit (4 embodiments), in
that the direction in which the sections of the winding are wound is different
(in one or opposing directions), and consequently there is a different
connection of the windings, and are also distinguished by the presence of a
25 secondary winding (in one embodiment there is no secondary winding).

TRANSFORMER

Field of the Invention

The invention relates to the field of electrical engineering and concerns
5 the basic electrical engineering equipment of electric power stations,
substations, power lines, in radio engineering, in devices for measuring,
automatic control and regulation.

Background Art

10 Transformers are electromagnetic static converters of electrical energy
which have two or more inductively coupled windings and are designed for the
conversion of an alternating (sinusoidal) current of one voltage into an
alternating current of another voltage with the same frequency.

The principle of operation of a transformer is based on the effect of
15 electromagnetic induction found by M. Faraday in 1831 (B.N. Sergeenko,
V.M. Kiselev, N.A. Akimova. Electrical Machines. Transformers. Pub.
"Vysshaya Shkola," Moscow, 1989, 350 pages). In accordance with specific
features of construction and use, transformers can be divided into power,
welding, measuring and special transformers.

20 Power transformers, which are a necessary element of an industrial
power network, have attained the most widespread use.

Transformers have two basic parts: a magnetic circuit and windings.
Furthermore, high-power transformers have a cooling system.

The magnetic circuit is the structural base for mounting and fixing
25 windings, taps and other elements of a transformer, and serve for amplification
of the magnetic coupling between the windings.

The part of the magnetic circuit on which the windings are arranged is
called the core, the remaining part, closing the magnetic circuit, is called the
yoke. The windings of a transformer serve to create a magnetic field by means
30 of which electrical power is delivered. The winding of the transformer to
which electrical power is applied is called the primary winding, while the
winding from which power is taken is called the secondary winding.

Known inventions are concerned with the creation of special transformers or with changes of particular structural elements of the transformer: realization of magnetic circuits from certain materials and their structural appearance, connection of magnetic circuits to each other where
5 there is an n number of magnetic circuits, use of different types of insulation and cooling systems, realization of the windings, additional elements in order to enhance noise immunity.

A transformer is known for vehicles [PCT (WO), 93/14508]. The small-size light transformer comprises a shell-type iron core on which inductively
10 coupled input and output windings are wound. A magnetic element with an air gap is provided between the input and output windings, while a magnetic element creating strong magnetic coupling is located between the output windings. The element is disposed in a gap 5d surrounded by the core and consists of a magnetic circuit without gaps and an insulating plate holding the
15 magnetic circuit and insulating it from the core and windings.

A transformer is known [PCT (WO), 93/16479], in which the core is made from ferromagnetic wire. A spirally wound core from ferromagnetic wire is proposed. The core is used in a differential current sensor in a switch to open a circuit, which operates when there is a short circuit to ground. The
20 ferromagnetic wire is wound in a spiral, the turns of which are parallel to each other and extend over the whole length of the core. The latter is positioned near current lines, with monitoring of a short circuit therein, wherein both lines are connected to a power source. The currents in them flow in opposite directions. The core interacts with a magnetic field created by those currents.
25 Where a ferromagnetic wire is used, it is possible to substantially increase the surface area of the core without increasing its cross section, and consequently, size.

A transformer is known [RU, C1, 2041514] consisting of one or several strip cores made from a magnetic alloy comprising silicon, boron, iron and
30 several windings inductively coupled to the core, wherein the magnetic alloy additionally comprises copper and one or several components selected from the group consisting of niobium, tantalum, tungsten, molybdenum, chromium, and

vanadium, with the following ratio of alloy components, atom percent: copper - 0.5-2.0; one or several components from the group consisting of niobium, tantalum, tungsten, molybdenum, chromium, vanadium - 2-5; silicon - 5-18; boron - 4-12; iron - balance.

5 A transformer is known [PCT (WO), 93/18529] comprising 3 or 4 types of insulation units with one winding. Transformers of this type are easily assembled with small expenditure of time.

A current transformer with strip insulation is known [RU, C1, 2046425] comprising a single-turn or multiturn primary winding and secondary windings
10 which are placed in a damping screen and have terminals. Wherein the aforesaid windings are secured by means of insertion support and connecting bushings and are covered with epoxy compounds. The transformer is additionally provided with insulation bushings, a screen which is placed on the primary winding, and support clamps. Insulation bushings are mounted in
15 semi-oval slots of the clamps, the damping screen is made open and consists of two parts, with an insulating pad mounted in the gap between the two parts, and the insertion support bushings are mounted on the insulating bushings in a manner adaptable for securing the damping screen.

A high-voltage transformer is known [RU, C1, 2035776] comprising a
20 porcelain housing mounted on a socket on which an active portion enclosed in the housing is positioned on compressing posts. The active portion consists of a mixed rectangular magnetic circuit with yokes, upper and lower horizontal cores on which windings are positioned. In order to reduce the noise immunity the transformer is provided with additional screens - a middle one,
25 upper and lower ones, and a capacitive screen.

A winding for a high-voltage transformer is known [PCT (WO), 93/18528]. A connecting element is secured to the conductive portion of the winding to enhance its mechanical properties, and a second connecting element is connected to the aforesaid connecting element by means of
30 insulating elements. Such a winding can be used as a low-voltage winding with a small number of turns in dry transformers with a resin poured over them.

A heavy-current transformer is known [RU, C1, 2027238] comprising a primary winding disposed on a toroidal core and a secondary winding encompassing the primary winding. Wherein the secondary winding is made by a bundle of flexible conductors placed in the inner cavity of the torus in N sections, and from the outer side of the torus in N-1 sections, where N is the number of turns of the secondary winding, wherein the bundle is arranged in one or more layers on the outer side of the torus.

However, all the known transformers are built according to one principle, in particular - supplying electrical power to the primary winding and taking electrical power from the secondary winding, and they all have these drawbacks:

- multiturn secondary windings in step-up transformers, which nevertheless operate in a rather narrow frequency range (50-400 Hz); the limited frequency range of the transformers being related to losses in the magnetic circuit at higher frequencies;

- high resistance of the windings, i.e. the necessity that the no-load condition of the transformer be taken into account during calculations of the number of turns in the secondary winding to obtain a predetermined output voltage;

- the complexity of the construction of the transformers when all possible kinds of additional elements, insulation etc. are used to reduce the aforesaid drawbacks.

Disclosure of the Invention

At the base of the invention lies the object of creating such a transformer in which the possibility of winding the secondary winding with wire, including wire with a cross-section equal to the cross-section of the primary winding, is realized, reduction of the number of turns in the secondary winding of high-voltage transformers and expansion of the number of variants of existing transformers are attained.

This object is achieved in that a construction of a transformer is proposed which comprises a magnetic circuit, at least two windings, inlets for a power supply, outlets for a load, wherein the primary winding consists of two

sections with an identical number of turns, the sections being connected to each other in a series circuit.

A transformer is proposed in which two sections of a primary winding are wound in one direction on one core of the magnetic circuit, the sections
5 are connected in a series circuit by connection of the outs of the windings, and the point of their connection serves as an outlet for the load, while the ins of the windings of the sections serve as inlets for the power supply.

The aforesaid technical result is achieved by creating a transformer, two sections of the primary winding of which are wound in one direction on one
10 core of the magnetic circuit, the outs of the windings of the sections are connected in a series circuit, while the ins of the section windings serve as inlets for the power supply.

The secondary winding is wound on the same core of the magnetic circuit, over the sections of the primary winding.

The aforesaid technical result is achieved by creating a transformer, two sections of the primary winding of which are wound in opposing directions on one core of the magnetic circuit, the out of the winding of the first section and the in of the winding of the second section are connected to each other in a series circuit, while the in of the winding of the first section and the out of the
20 winding of the second section serve as inlets for the power supply.

The secondary winding is wound on the same core of the magnetic circuit over the sections of the primary winding.

The indicated object is achieved by creating a transformer in which both sections of the primary winding are wound in one direction on two cores of one magnetic circuit, the out of the winding of the first section and the in of the winding of the second section are connected to each other in a series
25 circuit, while the in of the winding of the first section and the out of the winding of the second section serve as inlets for the power supply. The secondary winding is wound on both sections of the primary winding, encompassing both cores of the magnetic circuit.
30

The same technical result is achieved by creating a transformer in which both sections of the primary winding are wound in opposing directions on two

cores of one magnetic circuit, the outs of the windings of the sections are connected to each other in a series circuit, while the ins of the windings of the sections serve as inlets for the power supply.

5 The secondary winding is wound on both sections of the primary winding, encompassing both cores of the magnetic circuit.

10 The same technical result is achieved when both sections of the primary winding are wound in one direction on two cores of one magnetic circuit, wherein the in of the winding of the first section is connected to the out of the winding of the second section, the out of the winding of the first section is connected to the in of the winding of the second section, the points of their connection serve as inlets for the power supply.

The secondary winding is wound on both sections of the primary winding, encompassing both cores of the magnetic circuit.

15 The indicated object is achieved by creating a transformer in which two sections of the primary winding are wound in opposing directions on two cores of one magnetic circuit, both sections are connected to each other by connection of the ins and outs thereof respectively, and the points of their connection serve as inlets for the power supply.

20 The secondary winding is wound on both sections of the primary winding, encompassing both cores of the magnetic circuit.

25 The following lies at the base of the invention: sections of the primary winding are wound and connected to each other in such a manner that the magnetic flux created by one of such sections during operation of the transformer compensates the magnetic flux created by the other section of the primary winding.

30 If the two sections of the primary winding of the proposed transformer are connected to an alternating current network having a voltage U_1 , then a current i_0 will flow therealong. The magnetomotive force of one section of the winding $i_0 w_1$ due to the current i_0 creates an alternating magnetic flux F_1 in the magnetic circuit of the transformer. Similarly, a magnetomotive force $i_0 w_2$, which is equal to the mmf of the first section $i_0 w_1$, appears in the second section of the winding. Since the sections are connected to each other in a

series circuit, the alternating magnetic flux F_2 appearing in the second section of the primary winding and directed counter to the magnetic flux F_1 will compensate the magnetic flux of the first section F_1 . However, due to the induction of the mmf the permeability of the magnetic circuit changes. When
5 the network current drops during half-cycles, restoration of the permeability occurs in the magnetic circuit, and consequently, an electromotive force (emf) is induced in the primary and secondary windings. Wherein, during a half-cycle of current in the primary winding, the voltage in the secondary winding passes through a whole period.

10 In the case where both windings are wound in opposing directions with an identical number of turns, but are connected to each other in a series circuit by opposing leads (the out of the winding of the first section and the in of the winding of the second section), the magnetic flux in the primary winding i_0 will also be equal to zero, i.e. the same technical result can be attained as in
15 the case where the windings of both sections are wound in one direction. When R_H is connected to the secondary winding, the form of the voltage does not change. The output voltage depends on an increase of the number of turns in the secondary winding as compared with the number of turns in the primary winding.

20 Such a realization of the proposed transformer results in:

- 1) a reduction in the number of turns in the secondary winding by 10-20 times, and consequently, the dimensions of the transformer are reduced;
- 2) the possibility of winding the secondary winding with a thick wire having a cross section equal to the cross section of the wire in the primary
25 winding;
- 3) the secondary winding having a number of turns either greater or less than the number of turns in the primary winding, depending on the necessity of a high voltage at the output of the transformer.

Brief Description of the Drawings

30 Further the invention will be explained by a description of concrete examples of its embodiment and the accompanying drawings in which:

Fig. 1 shows the device being patented - a transformer in accordance with the invention (circuit);

Fig. 2 shows another embodiment of the transformer in accordance with the invention (circuit);

5 Fig. 3 shows one of the embodiments of the transformer in accordance with the invention (circuit);

Fig. 4 shows one more embodiment of the transformer in accordance with the invention (circuit);

10 Fig. 5 shows one more embodiment of the transformer in accordance with the invention (circuit);

Fig. 6 shows one of the embodiments of the transformer in accordance with the invention (circuit);

Fig. 7 shows one of the embodiments of the transformer in accordance with the invention (circuit);

15 Fig. 8 shows a stylized dependence of the increase of current and voltage in the primary and secondary windings of a transformer with a ferrite magnetic circuit;

Fig. 9 shows a stylized dependence of the increase of current and voltage in primary and secondary windings of sheet steel.

20 Best Variants of Carrying Out the Invention

A comprehensive description of embodiments of the transformer being patented in accordance with the invention is given below.

A transformer in accordance with the invention (according to the embodiment shown in Fig. 1) comprises a magnetic circuit 1, a first section 2
25 of a primary winding, a second section 3 of the primary winding, a_1 and x_1 - the in and out of the winding of the first section, a_2 and x_2 - the in and out of the winding of the second section of the primary winding, R_{H1} - the resistance of a load connected to the first section, R_{H2} - the resistance of a load connected to the second section of the primary winding. The two sections of
30 the primary winding are wound on the magnetic circuit 1: the first section 2, the second section 3 thereon in one direction, and they have an identical number of turns. The outs x_1 and x_2 of the windings are connected to each

other in a series circuit, while the ins a_1 and a_2 of the windings are separately connected to a power supply. A load resistance is connected parallel to each section of the winding: R_{H1} in the path of the current from the power supply to the first section of the winding and to the point of connection of the windings of the sections, and R_{H2} correspondingly to the second section of the primary winding.

A transformer in accordance with the invention according to the embodiment shown in Fig. 2 is made similar to the transformer according to the embodiment shown in Fig. 1. A distinction is in the presence of secondary winding 4, which is wound in a third layer on the sections 2 and 3 of the primary winding on the same core of the magnetic circuit 1. A and X designate the inlet and outlet (in and out of the phase) of the secondary winding, R_H - the resistance of the load connected to the leads A and X of the secondary winding.

A transformer in accordance with the invention according to the embodiment according to Fig. 3 is made similar to the transformer according to the embodiment shown in Fig. 2. A distinction is that the sections of the primary winding are wound in opposing directions. The out of the winding of the first section x_1 and the in of the winding of the second section a_2 are connected to each other in a series circuit, the other leads of the sections a_1 and x_2 serve as inlets for the power supply.

A transformer in accordance with the invention according to the embodiment shown in Fig. 4 is made similar to the transformer according to the embodiment shown in Fig. 2. A distinction is that the sections of the primary winding 2 and 3 are wound on two cores of the magnetic circuit 1. The sections are connected to each other via opposite leads - the out of the winding of the first section and the in of the winding of the second section. Secondary winding 4 is wound on both sections of the primary winding and encompasses both cores of the magnetic circuit.

A transformer in accordance with the invention according to the embodiment shown in Fig. 5 is made similar to the transformer according to the embodiment shown in Fig. 4. A distinction is that the two sections of the

primary winding are wound in opposing directions, the outs x_1 and x_2 of the windings of the sections are connected to each other in a series circuit, while the ins a_1 and a_2 of the windings of the sections serve as inlets for the power supply.

5 A transformer according to the embodiment shown in Fig. 6, in accordance with the invention, is made similar to the transformer according to the embodiment shown in Fig. 4. A distinction is that the in of the first section a_1 and the out of the second section x_2 , and also the out of the first section x_1 and the in of the second section a_2 are connected to each other, and
10 the points of their connection serve as inlets for the power supply.

A transformer according to the embodiment shown in Fig. 7, in accordance with the invention, is made similar to the transformer according to the embodiment shown in Fig. 6. A distinction is that the sections are wound in opposing directions, by the ins a_1 and a_2 and by the outs x_1 and x_2 the
15 windings of the sections are connected to each other, and the points of their connection serve as inlets for the power supply.

The principle of operation of the proposed transformer according to the embodiment shown in Fig. 1 is as follows.

I. Open circuit (no-load conditions)

20 The ins a_1 and a_2 of the windings of sections 2 and 3 are separately connected to a power supply U , the outs x_1 and x_2 of the windings of those same sections are connected to each other in a series circuit. Wherein a current i flows through the windings of those sections, this current causing the occurrence of a magnetomotive force mmf in each section of the winding
25 which is equal to iw . Since the fluxes in each section are equal and directed in opposing directions they are mutually compensated and reversal of magnetization of the core does not occur, but as a consequence of maintenance of the principle of superposition of magnetic fields in a magnetic circuit, the latter interacts with the fields on a microscopic level which results
30 in stressed interaction of a domain structure and a change in the magnetic permeability of the material of the magnetic circuit. Thus, a change of the current passing through the sections of the primary winding in time results in a

change of the permeability, while a change of the latter causes an emf to appear in those windings between the point of connection of the sections and the ins of the windings, but shifted by phase in time relative to the current passing from the supply source. Due to this, the voltage at the output of the transformer is increased by 10-20 times with actually just one primary winding.

II. Operating mode (with a load connected)

The load resistance R_{H1} is connected in the path of the current i from the power supply U to the first section 2 of the winding and to the point of connection of the outs of the sections, the load resistance R_{H2} is connected accordingly to the second section 3 of the winding. The current i from the power supply is passed through the formed closed loop, wherein the primary current i is increased in each loop proportionally to the load R_H , which results in a change of the emf in the loop - an increase of the emf.

At a low load resistance (equal to the resistance of the winding) the voltage U will be equal to the voltage drop on the winding, when the load resistance tends to increase to infinity, the secondary voltage U will increase proportionally, as a result of which the emf at the output of the transformer will increase dozens of times when there is one primary winding.

The principle of operation of the transformer according to the embodiments shown in Figs. 2-7 is similar to the principle of operation of the transformer according to the embodiment shown in Fig. 1.

A distinction lies in the presence of a secondary winding 4. Since the primary winding for the mmf in those embodiments remains open, a no-load emf is always induced therein, i.e. a self-inductance current is not created in the winding and all the mmf energy is provided as an emf of the secondary winding. Under such conditions, the intensity of the electric field per unit of length of the conductor of the winding in the secondary winding can exceed by ten times the intensity of the electric field in the primary winding, which is set by the power supply. As a result the secondary winding can have a fewer number of turns as compared with the primary winding, while the voltage is dozens of times greater than the mains voltage. Wherein the form of the

voltage and current in the secondary winding repeats the form of the voltage and current in the primary winding.

Fig. 8 shows a stylized dependence of the increase of current and voltage in the primary and secondary windings of a transformer with a ferrite magnetic
5 circuit.

It should be noted that the permeability μ of the magnetic circuit changes in time in the following manner with a sinusoidal form of current: it increases from 0 to $\pi/4$, then from $\pi/4$ to $\pi/2$ it drops, and from $\pi/2$ to $\pi 3/4$ the speed of restoration of the permeability again increases and from $\pi 3/4$ to π
10 the restoration of μ is slower. As a result of such a change of the magnetic permeability, an emf is induced in the secondary winding at a doubled frequency and there is a complete period of the secondary current for one half-period of the current in the primary winding.

Fig. 9 shows a stylized dependence of an increase of current and voltage
15 in the primary and secondary windings of a transformer with a magnetic circuit of sheet steel. With this type of magnetic circuit there is a shift of the form of the primary and secondary current curve from $\pi/6$ to $\pi/4$ while the form of the current is maintained.

The transformation ratio for each type of transformer was experimentally
20 determined.

Concrete examples of operation of different types of transformers are given below in order to better understand the invention. The same results were obtained with embodiments of transformers for which examples are not provided.

25 Example 1. M600HH-8 K100-60-15 ferrite rings were used as the magnetic circuit. Two sections of the primary winding, one over the other, were wound on a core of the magnetic circuit assembled from four rings. The outs of the windings of both sections were connected in a series circuit, a load resistance R_H was connected parallel to each section - one end to the point of
30 connection of the sections, the other - to the ins of the sections, the ins of the windings of each section were connected to the power supply. The number of

turns in the sections was identical and equal to 60. The transformation ratio for this transformer was 11. The results of measurement of the voltage at the output of the transformer are presented in Table 1, example 1.

Similar results were obtained when the transformer was made with a ferrite U-shaped magnetic circuit.

Example 2. A ring-type magnetic circuit made from sheet steel and designed for a power of 2.5 kW was used as the magnetic circuit. Two sections of the primary winding were wound on the core of the magnetic circuit, wherein both sections were wound in one direction with their outs connected in a series circuit, the ins of the sections connected to the power supply. A secondary winding was wound on the primary winding (the direction in which it is wound does not affect the operation of the transformer).

The transformation ratio was determined experimentally and was equal to 5.

The number of turns of one section of the primary winding was 110, the number of turns of the secondary winding was also equal to 110, the diameter of the wires in the primary and secondary windings was identical and equal to 1.2 mm. A load was connected to the leads of the secondary winding. The voltage was measured at the input of the primary winding and at the output of the secondary winding, i.e. on the load. The results of measurements are presented in Table 1, example 2.

Example 3. U-shaped ferrites were used as the magnetic circuit. The magnetic circuit was assembled from four units. Two sections of the primary winding were wound on the two cores of the magnetic circuit, each section on one core. The sections were wound in opposing directions, but with an identical number of turns. The total number of turns in the primary winding was 120. The outs of the windings of the sections were connected in a series circuit, the ins were connected to a power supply. A secondary winding, encompassing both cores, was wound on the primary winding. The number of turns in the secondary winding was 120. The transformation ratio was determined and found equal to 10. The results are presented in Table 1, example 3.

Example 4. A U-shaped magnetic circuit made from sheet steel was used as the magnetic circuit. Two sections of the primary winding were wound on both cores of the magnetic circuit, each section on one core. The sections were wound in one direction, the number of turns in each section was 120. The out of the winding of the first section and the in of the winding of the second section, and also the in of the winding of the first section and the out of the winding of the second section were connected to each other, and the points of their connection were connected to the power supply. The secondary winding was wound on the primary winding, the number of turns in the secondary winding was 120.

The transformation ratio of this transformer was 8.5. The results of measurement are presented in Table 1, example 4.

Table 1

	Voltage at the output of the transformer									
	U_{primary}, V	100	200	300	400	500	600	700	800	900
	$U_{\text{secondary}}, V$									
Example 1	1100	2200	3300	4400	5500	6600	7700	8800	9900	
Example 2	500	1000	1500	2000	2500	3000	3500	4000	4500	
Example 3	1000	2000	3000	4000	5000	6000	7000	8000	9000	
Example 4	850	1700	2550	3400	4250	5100	5050	6800	7650	

25

Industrial Applicability

Samples of all types of transformers were made and have been working for from three to five years. All these samples were tested and can serve as electrical engineering equipment in laboratory practice and in industrial enterprises.

30

Claims:

1. A transformer comprising a magnetic circuit, at least two windings, inlets for a power supply, outlets for a load, characterized in that a primary winding consists of two sections with an identical number of turns, the sections being connected to each other in a series circuit and mutually compensating the magnetic fluxes of each other, and wherein two sections of the primary winding are wound in one direction on one core of the magnetic circuit, the sections are connected in a series circuit by connection of the outs of the windings, and the point of their connection serves as an outlet for the load, the ins of the windings of the sections serve as inlets for the power supply.
2. A transformer according to claim 1, characterized in that the two sections of the primary winding are wound in one direction on one core of the magnetic circuit, the sections are connected in a series circuit by connection of the outs of the windings, the ins of the windings of the sections serve as inlets for the power supply.
3. A transformer according to claim 1, characterized in that the two sections of the primary winding are wound in opposing directions on one core of the magnetic circuit, the out of the winding of the first section and the in of the winding of the second section are connected to each other in a series circuit, while the in of the winding of the first section and the out of the winding of the second section serve as inlets for the power supply.
4. A transformer according to anyone of claims 2 and 3, characterized in that the secondary winding is wound on the same core of the magnetic circuit over the sections of the primary winding.
5. A transformer according to claim 1, characterized in that the two sections of the primary winding are wound in one direction on two cores of one

magnetic circuit, the out of the winding of the first section and the in of the winding of the second section are connected to each other in a series circuit, while the in of the winding of the first section and the out of the winding of the second section serve as inlets for the power supply.

6. A transformer according to claim 1, characterized in that the two sections of the primary winding are wound in opposing directions on two cores of one magnetic circuit, the outs of the windings of the sections are connected to each other in a series circuit, while the ins of the windings serve as inlets for the power supply.

7. A transformer according to claim 1, characterized in that the two sections of the primary winding are wound in one direction on two cores of one magnetic circuit, wherein the in of the winding of the first section is connected to the out of the winding of the second section, the out of the winding of the first section is connected to the in of the winding of the second section, the points of connection of the sections serve as inlets for the power supply.

8. A transformer according to claim 1, characterized in that the two sections of the primary winding are wound in opposing directions on two cores of one magnetic circuit, both sections of the winding are connected to each other by their ins and outs, and the points of their connection serve as inlets for the power supply.

9. A transformer according to anyone of claims 5-8, characterized in that the secondary winding is wound on both sections of the primary winding, encompassing both cores of the magnetic circuit.

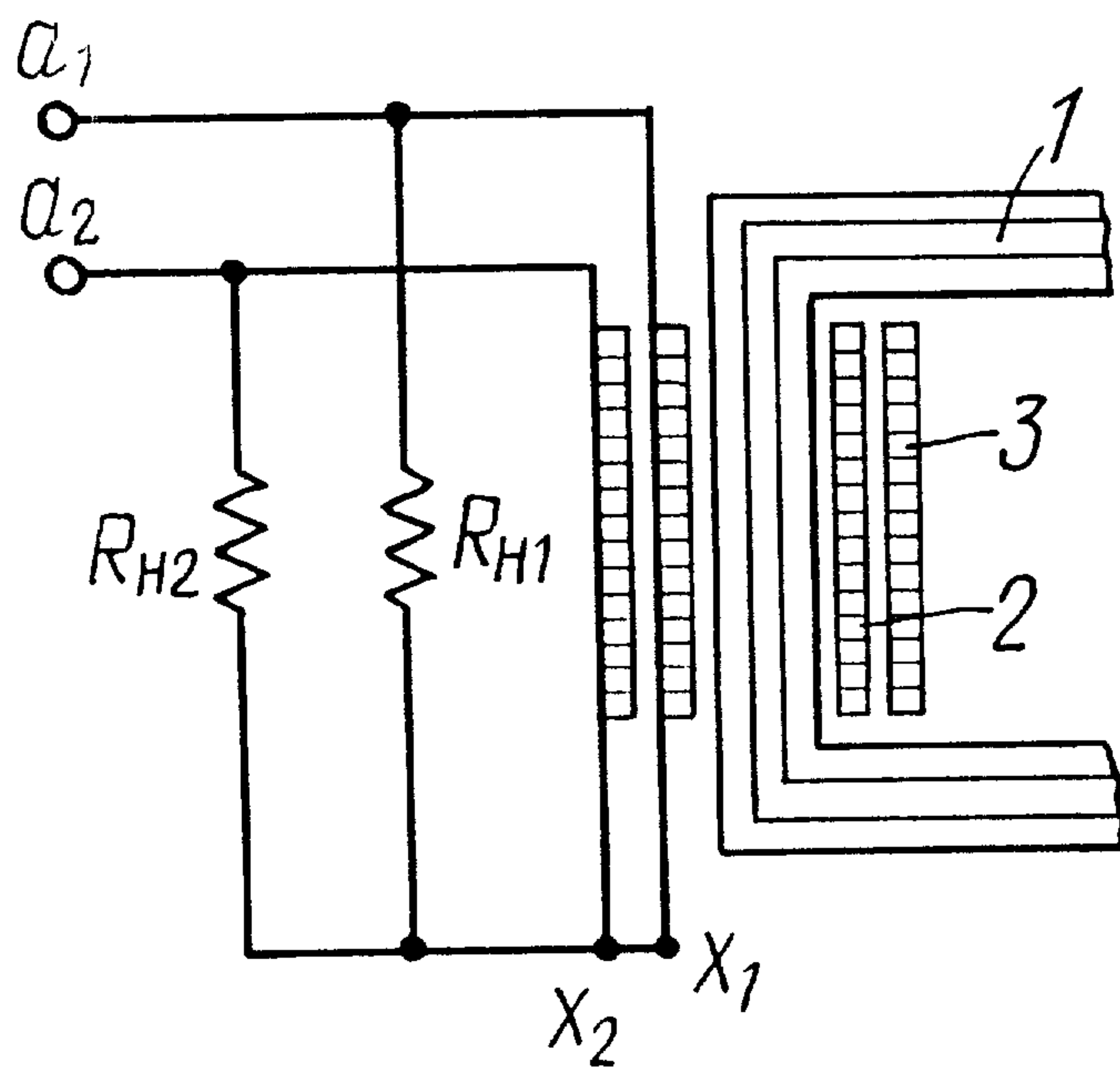

FIG. 1

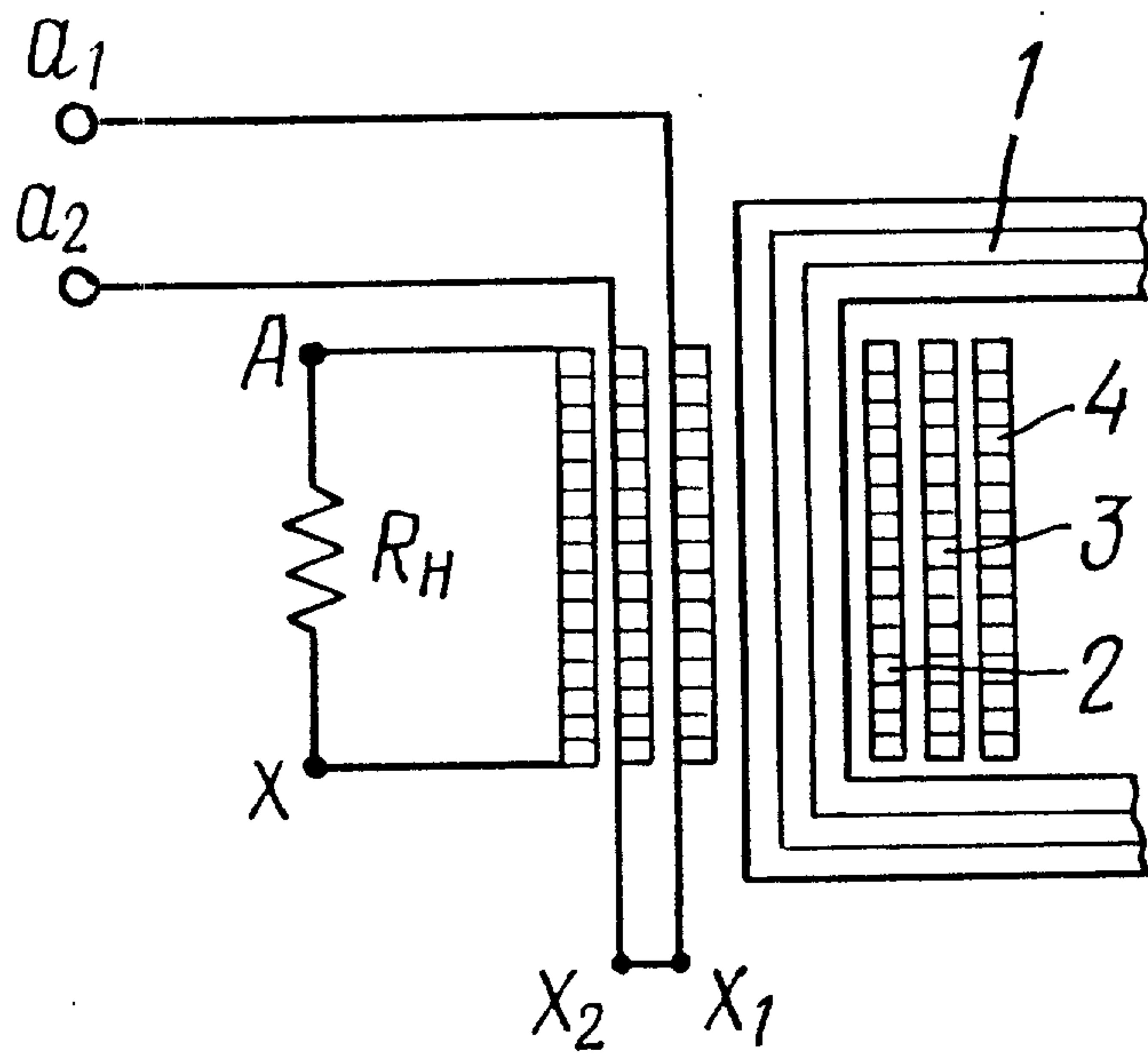

FIG. 2

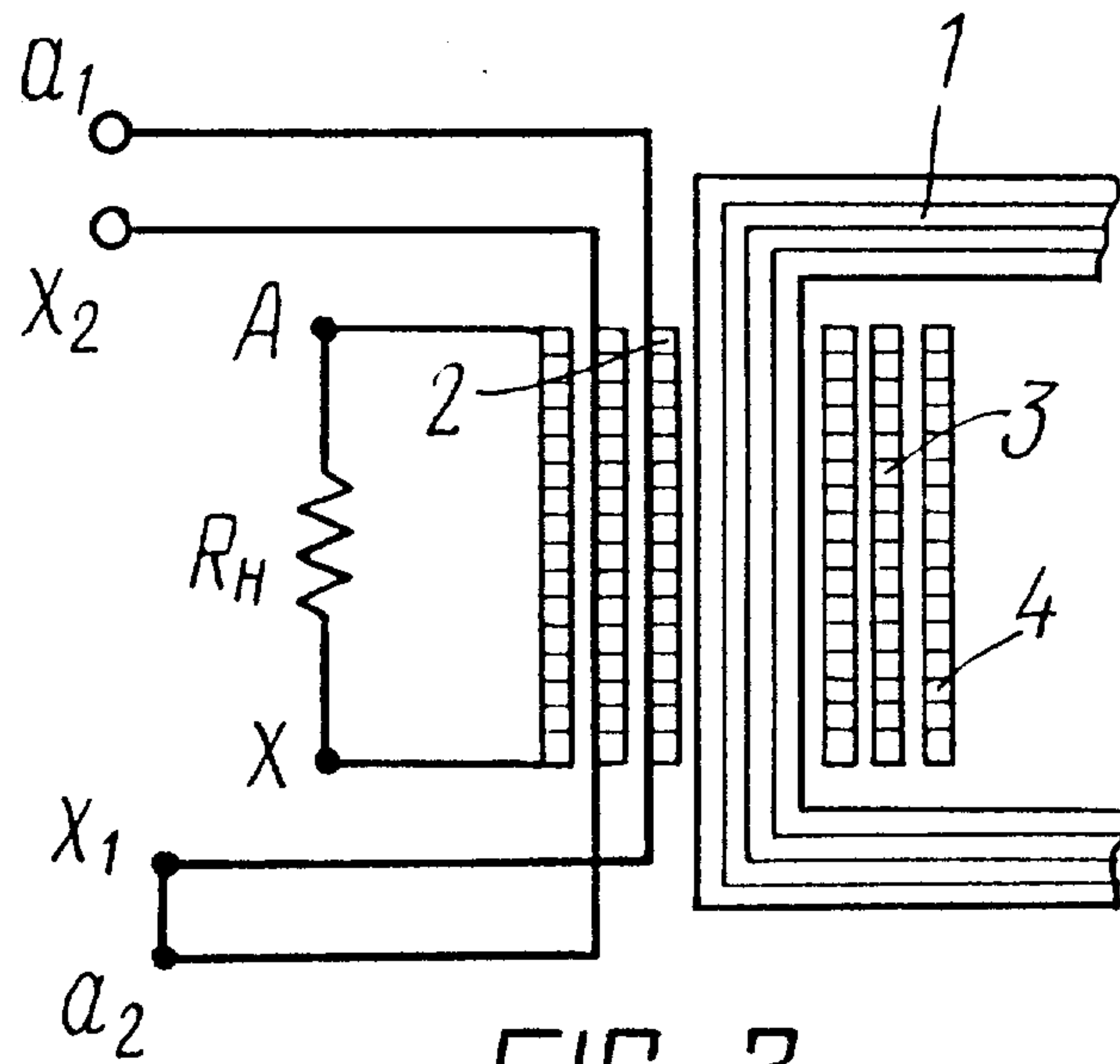

FIG. 3

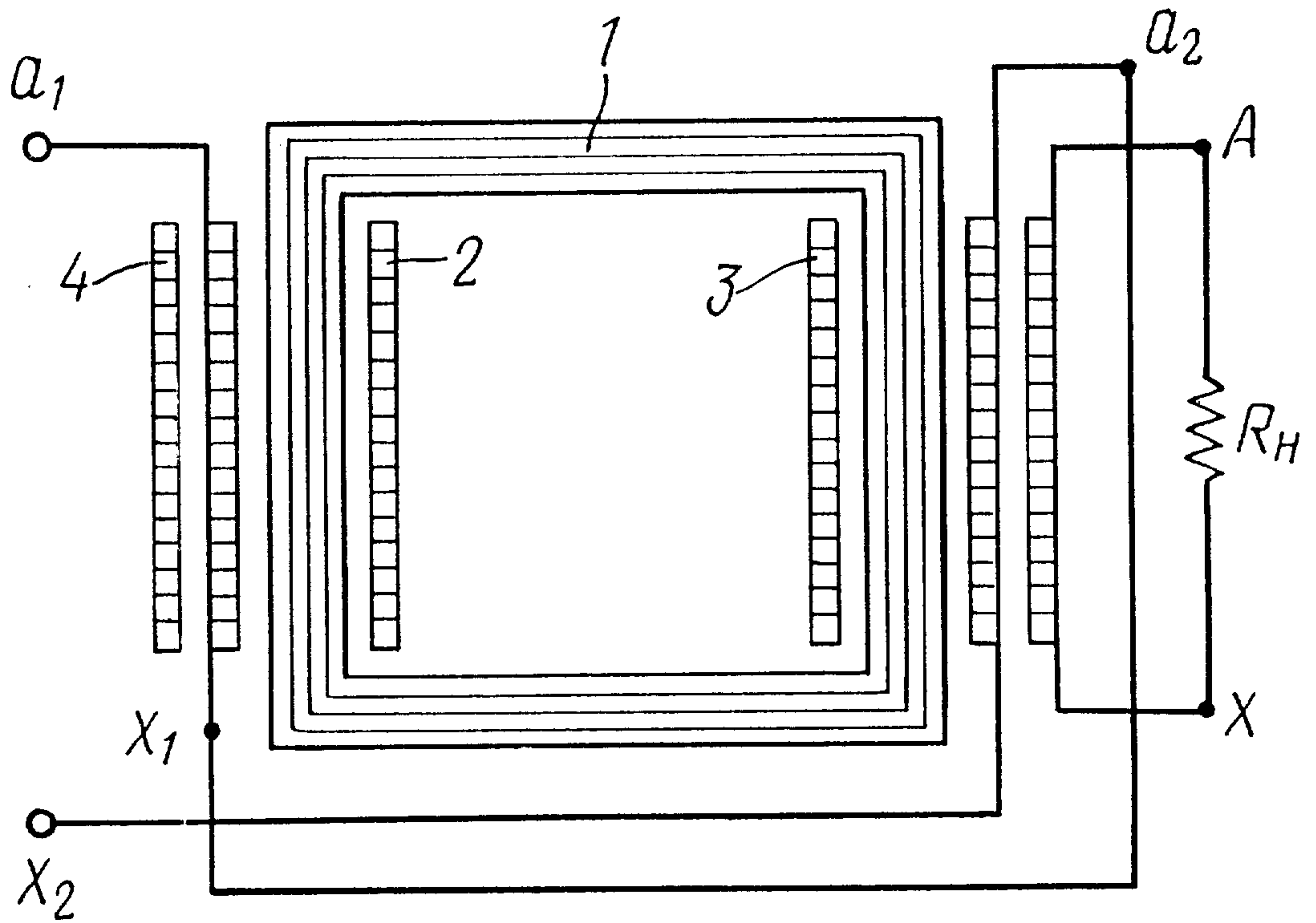

FIG. 4

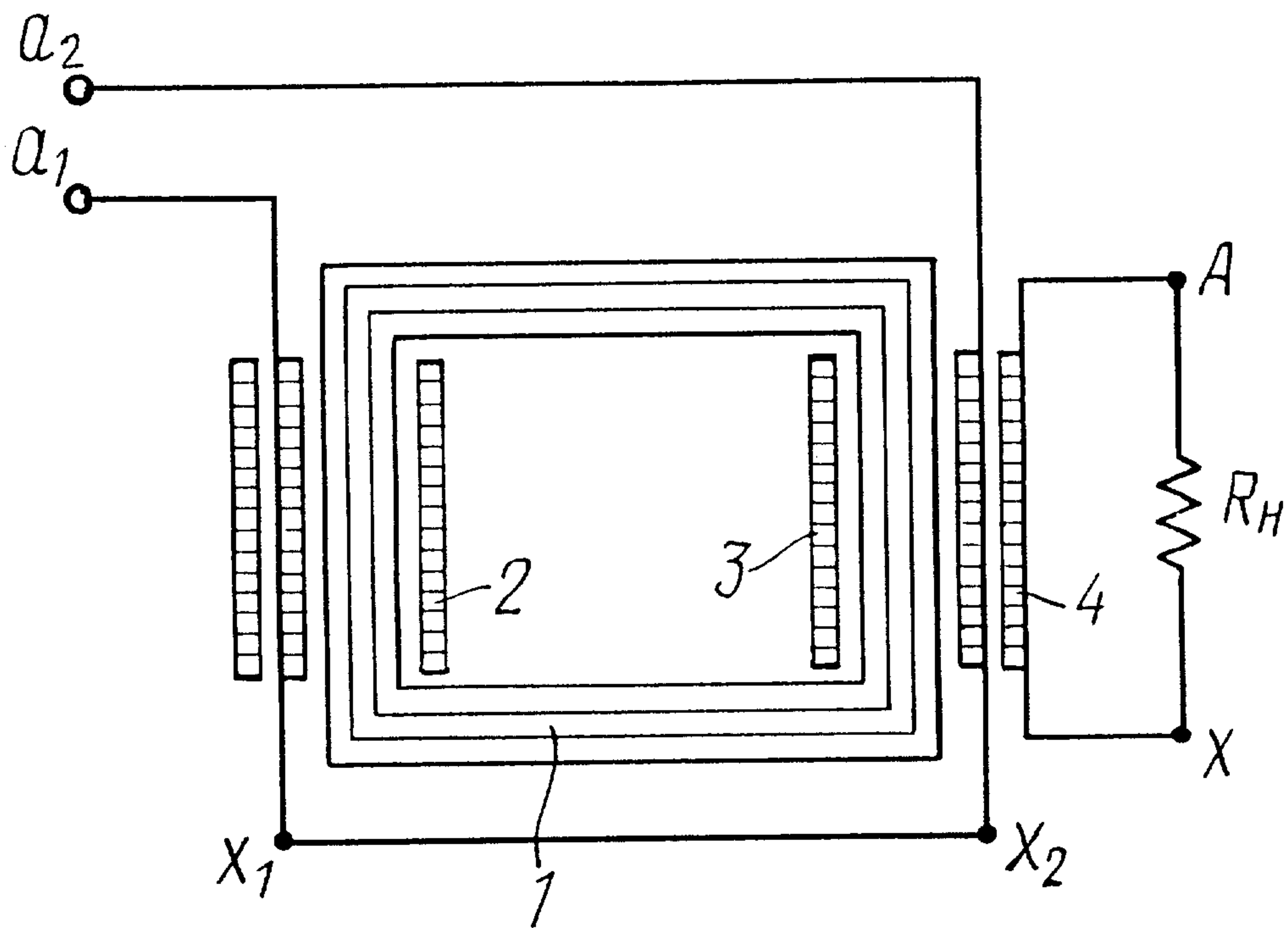

FIG. 5

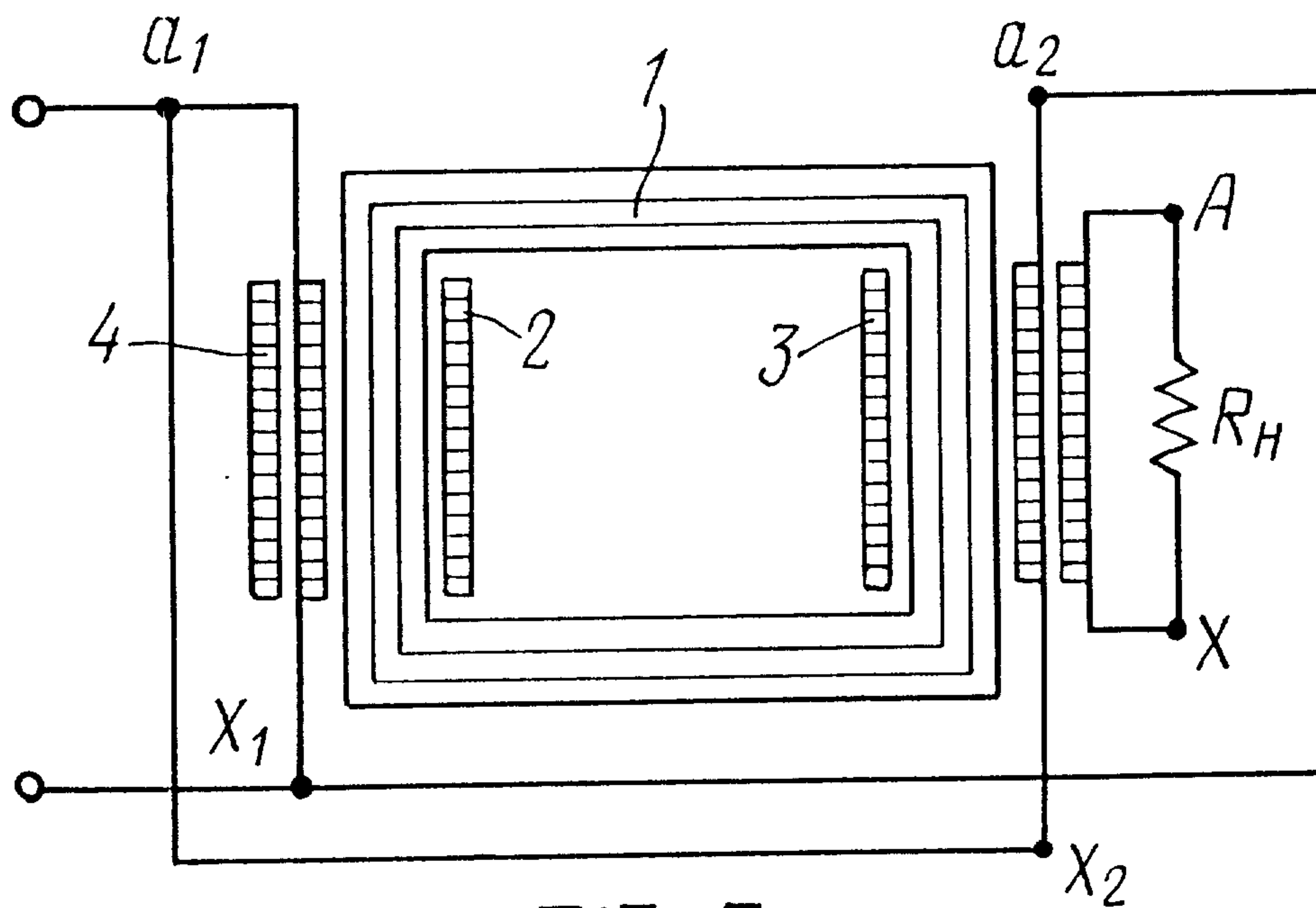

FIG. 6

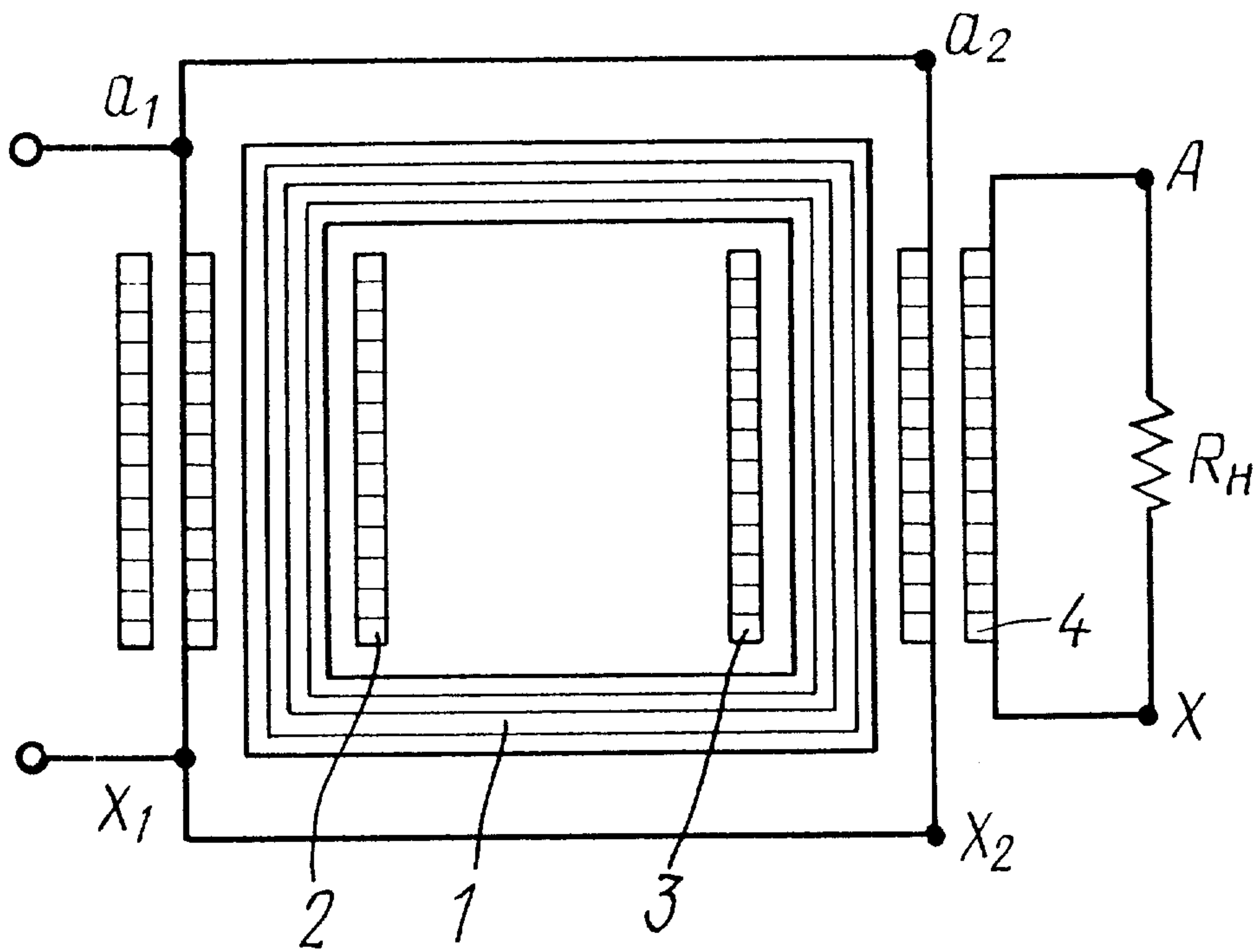

FIG. 7

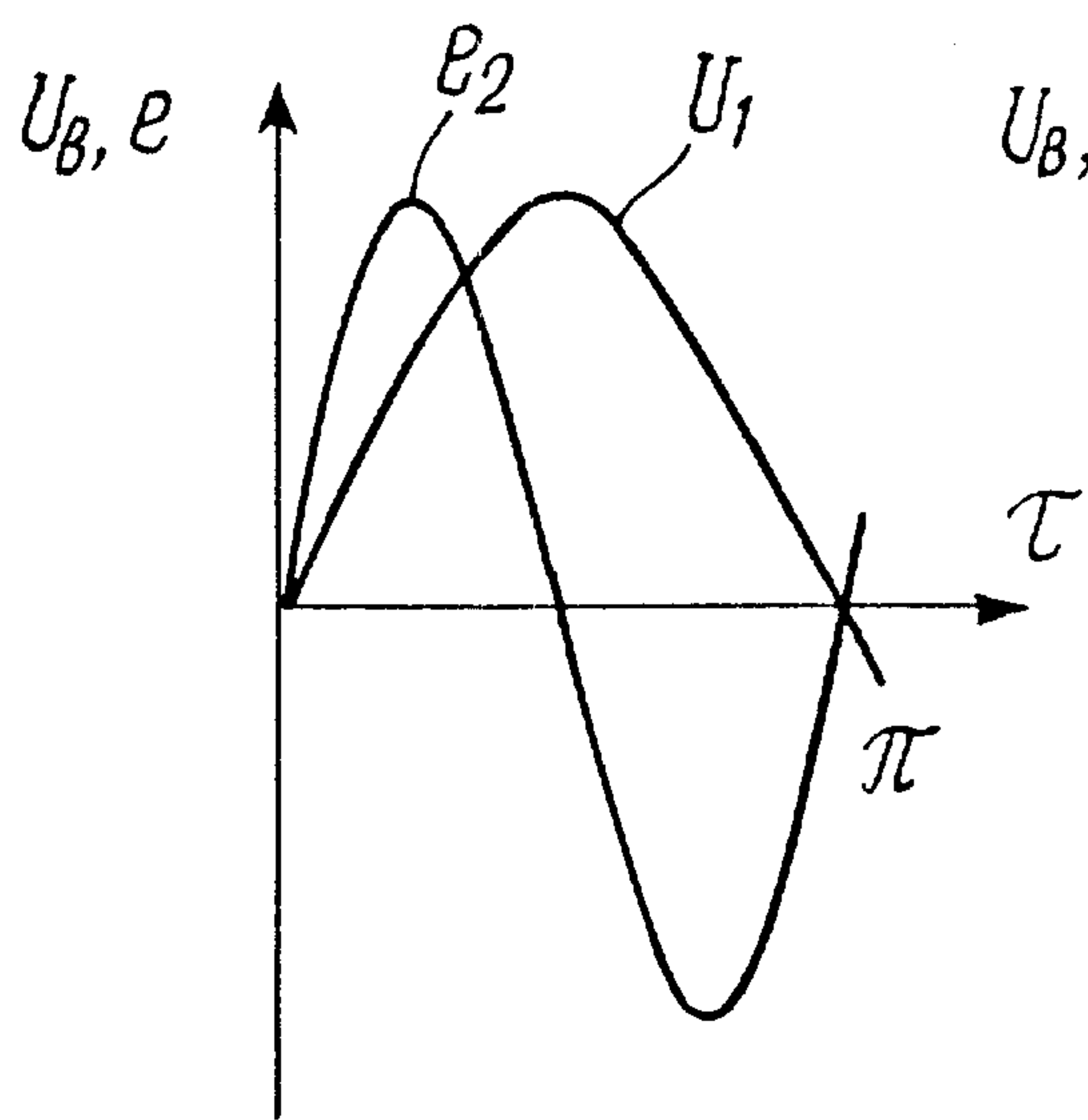

FIG. 8

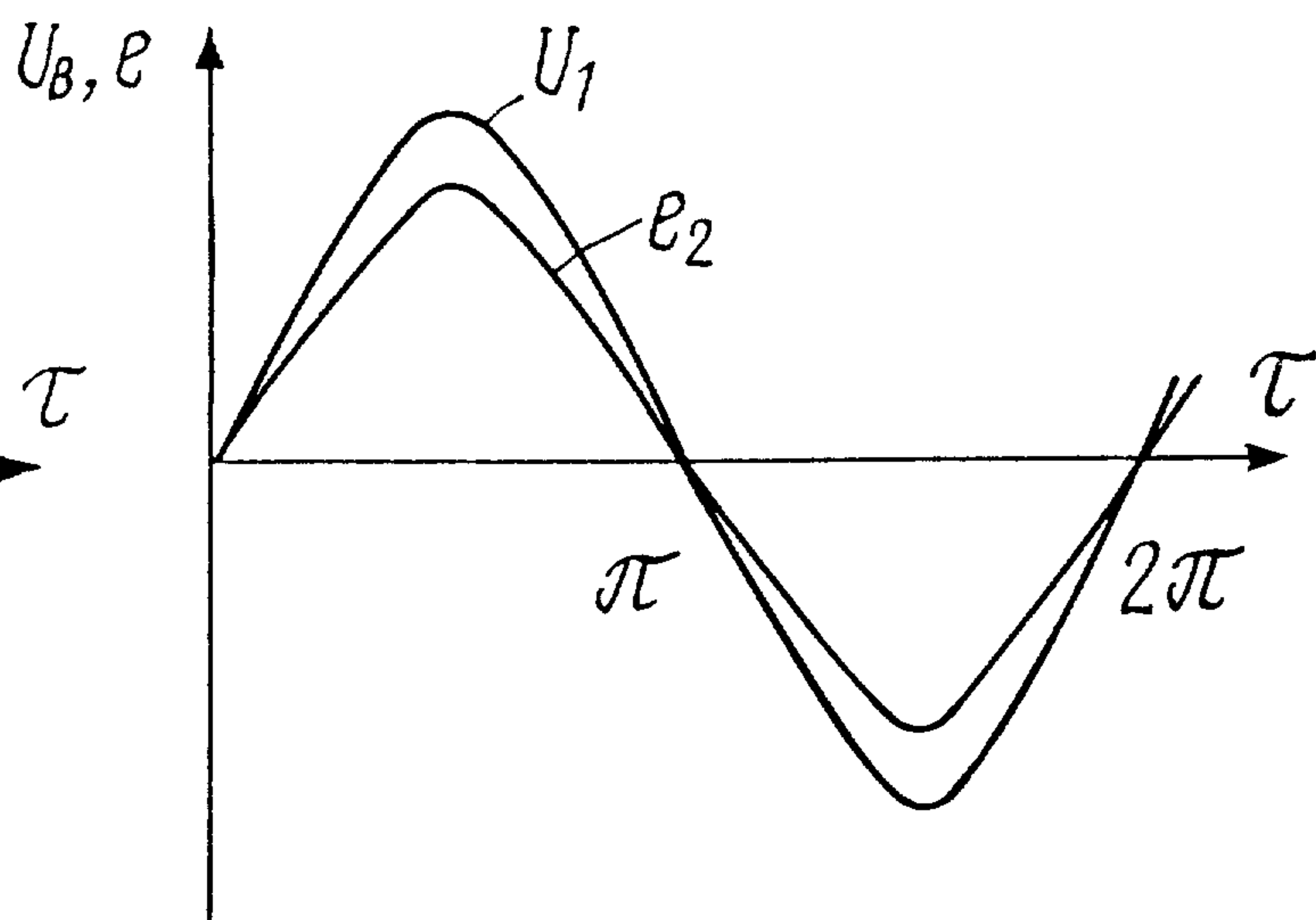

FIG. 9

