

(19) World Intellectual Property Organization
International Bureau



(43) International Publication Date
7 June 2007 (07.06.2007)

PCT

(10) International Publication Number
WO 2007/063368 A1

(51) International Patent Classification:
D06F 37/06 (2006.01) *D06F 39/02* (2006.01)

[IT/IT]; Via Regina Margherita 34, I-74020 Leporano (TA) (IT). **VOTA, Roberto** [IT/IT]; Via Lorazzo Inferiore 25, I-13061 Andorno Micca (VC) (IT).

(21) International Application Number:
PCT/IB2006/002630

(74) Agent: **DINI, Roberto**; c/o Metroconsult S.r.l., Via Sestrieri, 100, 10060 None (TO) (IT).

(22) International Filing Date:
22 September 2006 (22.09.2006)

(81) Designated States (unless otherwise indicated, for every kind of national protection available): AE, AG, AL, AM, AT, AU, AZ, BA, BB, BG, BR, BW, BY, BZ, CA, CH, CN, CO, CR, CU, CZ, DE, DK, DM, DZ, EC, EE, EG, ES, FI, GB, GD, GE, GH, GM, HN, HR, HU, ID, IL, IN, IS, JP, KE, KG, KM, KN, KP, KR, KZ, LA, LC, LK, LR, LS, LT, LU, LV, LY, MA, MD, MG, MK, MN, MW, MX, MY, MZ, NA, NG, NI, NO, NZ, OM, PG, PH, PL, PT, RO, RS, RU, SC, SD, SE, SG, SK, SL, SM, SV, SY, TJ, TM, TN, TR, TT, TZ, UA, UG, US, UZ, VC, VN, ZA, ZM, ZW.

(25) Filing Language: Italian

(26) Publication Language: English

(30) Priority Data:
TO2005A000852 2 December 2005 (02.12.2005) IT

(71) Applicant (for all designated States except US): **INDESIT COMPANY S.P.A.** [IT/IT]; Viale Aristide Merloni No. 47, I-60044 Fabriano (AN) (IT).

(72) Inventors; and

(75) Inventors/Applicants (for US only): **MARIOTTI, Costantino** [IT/IT]; Via Giacomo Leopardi 16, I-06028 Sigillo (PG) (IT). **BOMBARDIERI, Giovanni** [IT/IT]; Via Guglielmo Marconi 22, I-24021 Albino (BG) (IT). **D'ALESSANDRO, Luisa** [IT/IT]; Via Centrale Elettrica 10, I-67038 Scanno (AQ) (IT). **COLUCCI, Nicola**

(84) Designated States (unless otherwise indicated, for every kind of regional protection available): ARIPO (BW, GH, GM, KE, LS, MW, MZ, NA, SD, SL, SZ, TZ, UG, ZM, ZW), Eurasian (AM, AZ, BY, KG, KZ, MD, RU, TJ, TM), European (AT, BE, BG, CH, CY, CZ, DE, DK, EE, ES, FI, FR, GB, GR, HU, IE, IS, IT, LT, LU, LV, MC, NL, PL, PT, RO, SE, SI, SK, TR), OAPI (BF, BJ, CF, CG, CI, CM, GA, GN, GQ, GW, ML, MR, NE, SN, TD, TG).

[Continued on next page]

(54) Title: HOUSEHOLD APPLIANCE WITH AT LEAST ONE LIFTER COMPRISING MEANS FOR CONTAINING WASHING AGENTS

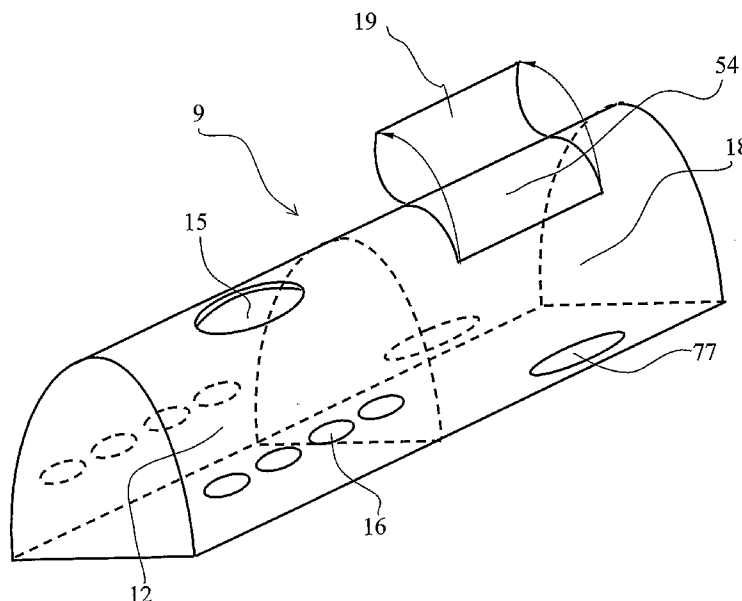

(57) Abstract: The present invention relates to a household appliance (1), in particular adapted to carry out at least one wash treatment on textile items, comprising a rotating drum (3) adapted to contain the textile items to be treated, and at least one element (9) adapted to drag and/or lift the textile items during the treatment. According to the present invention, said element (9) comprises means for containing washing and/or additive agents.

WO 2007/063368 A1



Published:

— with international search report

For two-letter codes and other abbreviations, refer to the "Guidance Notes on Codes and Abbreviations" appearing at the beginning of each regular issue of the PCT Gazette.

HOUSEHOLD APPLIANCE WITH AT LEAST ONE LIFTER COMPRISING MEANS FOR CONTAINING WASHING AGENTS

DESCRIPTION

The present invention relates to a household appliance, in particular adapted to carry out at least one wash treatment on textile items, according to the preamble of claim 1.

5 Laundry washing machines are generally provided with a drawer-type washing agent dispenser, which comprises one or more washing agent compartments adapted to be filled with volumes of washing agents. The washing agents are released by means of a water flow which, by passing through said compartments, carries said washing agents to the wash tub. The laundry washing machines known in the art therefore comprise a dedicated hydraulic circuit for carrying the washing agents to the tub. Such a circuit consists of a considerable number of components, including one or more valves (generally there are two valves: one for carrying prewash-specific detergent and one for carrying wash-specific detergent). Consequently, in prior-art laundry washing machines said circuit contributes significantly to the cost of the machine.

15 Besides, prior-art laundry washing machines suffer from the drawback of requiring much time for mounting the washing agent dispenser and the hydraulic circuit components: said time extends the overall production time of washing machines. Furthermore, since the components of said hydraulic circuit (especially the valves) are subject to failure, it follows that the presence of said circuit reduces the reliability of washing machines, resulting in possible inconvenience for both the manufacturer and the user. Finally, the dispenser and the associated hydraulic circuit are bulky inside the cabinet of the washing machine, which space could otherwise be used for housing other devices. As far as the drawer-type dispenser is concerned, it must also be said that, in addition to a portion of
20 the internal volume of the cabinet, it also occupies a portion of the front surface of laundry washing machines (precisely that portion of the front which corresponds to the visible surface of the drawer-type dispenser and which allows the users to access the dispenser in order to fill it with washing agents), so that

the presence of a drawer-type dispenser considerably reduces the surface available to user interface devices and may even compromise the harmony of the laundry washing machine.

The object of the present invention is to overcome the above drawbacks in a simple and economical way.

Said object is achieved through the household appliance incorporating the features set out in the annexed claims, which are intended as an integral part of the present description.

The general idea at the basis of the present invention is to provide a household appliance, in particular adapted to carry out at least one wash treatment on textile items, being without the traditional drawer-type dispenser and the associated hydraulic circuit.

In order to provide such a household appliance, the Applicant has thought of associating means adapted to contain washing agents with one of the components being present inside the appliance: said component, in particular, meets the requirement of coming into contact with water during the operation of the household appliance. In particular, the Applicant has found the so-called "lifter" (i.e. the element adapted to drag and/or lift the textile items during the treatments) to be the component most suited to being associated with means for containing washing agents.

The present invention will become apparent, together with its further advantages, from the following detailed description and from the annexed drawings, which are supplied by way of non-limiting example, wherein:

- Fig.1 shows schematically a household appliance according to the present invention;
 - Fig.2 shows schematically a particular component, precisely a lifter, of the household appliance according to the present invention;
 - Fig.3A shows schematically a first sectional view of the component illustrated in Fig.2 and
 - Fig.3B shows schematically a second sectional view of the component illustrated in Fig.2, the section plane of Fig.3B being the same as that of Fig.3A.
- Fig.1 illustrates a household appliance, in particular adapted to carry out at least

one wash treatment on textile items, which represents a possible embodiment of the present invention, described herein by way of non-limiting example. The household appliance of Fig.1 will hereafter be referred to as “washing machine”: it is worth specifying that the term “washing machine” includes any household appliance which is capable of carrying out at least one wash treatment on textile items (and therefore also the appliance traditionally called “washing/drying machine”), whether of the front-loading or top-loading type. Preferably, the appliance called “washing machine” can also carry out at least one spin treatment on textile items, according to which a certain quantity of water is wrung out from the textile items by moving them at a speed being much higher than the speed used for the wash treatment. As a non-limiting example of the household appliance according to the present invention, Fig.1 shows a substantially front-loading washing machine.

The washing machine 1 comprises a rotating drum 3, adapted to contain the textile items to be treated, and at least one element 9, adapted to drag and/or lift the textile items during the wash treatment, which comprises means for containing washing and/or additive agents. Hereafter, the dragging and/or lifting element 9 will be referred to as “lifter”, this name being commonly used in this technical field.

The drum 3 is a hollow cylindrical element, which can rotate about its axis 8. It comprises two substantially circular walls extending perpendicularly to the axis 8 and a cylindrical surface extending parallel to the axis 8; one of the two circular walls comprises a circular aperture for loading the textile items, and the surface comprises a plurality of holes for allowing the water used during the wash treatment to flow through; said drum can be made of plastic material or metal. The drum 3 is located inside a tub adapted to contain water and used for carrying out a wash treatment on textile items. The drum 3 can be accessed by the user through a door connected to the cabinet 10 of the washing machine by means of one or more hinges.

The lifter 9 is special, since it comprises means for containing washing and/or additive agents; typically there will also be a plurality of traditional lifters 80;90 (preferably three or four), which may be made of plastic, preferably coated with a

layer of soft and/or elastic material: in this way, the textile items are not subject to the slight damages due to fouling and/or friction against the lifters during the rotation of the drum 3.

5 The lifter 9 is secured to the drum 3 in such a way that it is adjacent to the inner face of the drum 3, in particular to the inner face of the surface of the drum 3. Like any other lifters 80;90 possibly present in the washing machine 1, it may be made of plastic material and coated with a layer of a soft and/or elastic material. However, it may differ in shape and volume from the other lifters 80;90 possibly present in the washing machine 1.

10 The agents, in particular detergents, may be loaded into the respective container means comprised in the lifter 9 in different ways. For example, according to a particularly simple and economical embodiment of the lifter 9, on the outer surface of the lifter a slot may be obtained for loading agents therethrough (the slot may preferably be used for loading powder or liquid detergents). As an
15 alternative to said slot, a lid may be used (the lid can be used by the user for comfortably and easily loading any kind of detergent, even tablets). As a further alternative, the lifter may be so provided as to comprise at least one removable element (e.g. a cover), which allows the user of the washing machine 1 to load the agents more easily. Still for the purpose of making it easier to load the
20 washing agents into the lifter 9, the connection between the lifter 9 and the drum 3 may be a removable connection: thus, the user can first load the agents into the respective means, outside the washing machine 1, and then secure the lifter 9 to the drum 3.

The container means comprised in the lifter 3 are characterized by self-releasing
25 the agents, and therefore they do not require a dedicated hydraulic circuit for carrying the agents to the wash tub. According to the embodiment example of Fig.2, during the operation of the washing machine 1 the lifter 9 comes directly in contact with the water (contained in the wash tub), which can access said container means freely through suitable apertures adapted to put the wash tub in
30 communication with the agent container means. The shape of said apertures and the position thereof on the lifter 9 are optional and may be provided in many different ways for the purposes of the present invention: by way of example, it is

conceivable to provide suitable holes to prevent the agents from flowing out while they are being loaded (e.g. by locating them in high positions) and to allow the water to enter the lifter 9, or else, if there is an agent loading slot, said slot may also be exploited to allow the water to enter the lifter 9. Once it has reached
5 the container means, the water washes away the agents (also by dissolving them, e.g. powder detergents), which are then immediately available to carry out the wash treatment on the textile items being present inside the drum 3.

According to a particularly advantageous embodiment of the present invention, the lifter comprises both means adapted to contain at least one washing agent and
10 means adapted to contain at least one additive agent, i.e. at least one agent like a liquid softener.

Said additive agent is adapted, for example, to be dispensed and/or used during the spin treatment, rather than during the wash treatment. In this embodiment, the additive agent container means are associated with means adapted to first retain
15 the additive agent in the lifter 9 during the wash treatment and then to allow it to be released during the spin treatment preceding the final rinse, wherein said additive agent is normally used.

Fig.2 shows, by way of example and not by way of limitation, a lifter 9 manufactured according to the innovative teachings of the present invention. The
20 lifter 9 comprises two distinct compartments separated from each other: a first compartment 12, for containing a washing agent, and a second compartment 18, for containing an additive agent. The volume of said two compartments is such that they can contain appropriate amounts of washing agents for carrying out a wash treatment and/or appropriate amounts of additive agents for carrying out
25 one of the treatments requiring the use of additive agents: for example, the first compartment 12 and the second compartment 18 may be so shaped as to contain at least 300 cm³ of detergent in powder and at least 120 cm³ of liquid softener, respectively. The positioning of the two compartments along the lifters 9 may be such that the direction joining both compartments extends mostly axially (i.e.
30 said joining straight line is substantially parallel to the axis 8 of the drum 3): it may be assumed that the first compartment 12 is arranged on the front portion of the drum 3 (wherein the "front portion" is the portion adjoining the circular

aperture of the drum 3 of the washing machine 1) and that the second compartment 18 is arranged on the rear portion of the drum 3.

For loading the washing agent (e.g. detergent in powder, or liquid detergent, or detergent in tablets), a slot 15 is obtained on the outer surface of the lifter 9, which slot is located above the first compartment 12 and communicates therewith, so that the washing agent poured in by the user through the slot 15 deposits by gravity within the first compartment 12. On the outer surface of the lifter 9, means are also obtained which are adapted to ensure the spontaneous release of the washing agents from the first compartment 12. In order to provide this function, the slot 15 may advantageously be associated with a series of holes 16, located sideways relative to the first compartment 12, in high positions relative to the bottom of the first compartment 12 and communicating therewith, adapted to allow the water contained in the tub during the wash treatment to flow into the first compartment 12 and wash away the washing agents.

For loading the additive agent (e.g. liquid softener, or bleach), a lid 19 is housed on the outer surface of the lifter 9, which lid is used for obstructing a corresponding inlet section 54 belonging to the second compartment 18. The user opens the lid 19, loads the additive agent, which accumulates by gravity in the second compartment 18, and then, before loading the textile items into the drum 3, closes the lid 19. Closing the lid 19 prevents the water contained in the tub during the wash treatment from flowing into the second compartment 18 through said inlet section 54 and from washing away the additive agent contained therein into the tub.

In accordance with the typical peculiarity of additive agents of not being effective during the wash treatment, but only during a dedicated treatment, the lifter 9 is fitted with a system, associated with the second compartment 18 and the lid 19, adapted to provide a time-selective release of additive agents from the second compartment 18.

The factor, on which the above system perform is based to a selective release of agents, in particular of the additive agent, may be, for example and preferably, the rotation speed of the drum of the household appliance.

As a reminder, the rotation speed of the drum during the spin treatment (wherein

rotation speeds ω of hundreds of revolutions per minute are reached) is significantly higher than during the wash treatment (wherein rotation speeds ω of tens of revolutions per minute are reached); as known, the spin treatment is used for removing liquid (generally the rinse liquid) from the items being present in the drum.

According to the present invention, one or more spin phases may be provided (preferably short, e.g. lasting 10 seconds to 30 seconds), i.e. at high speed (e.g. between 100 rpm and 1,500 rpm and preferably between 300 rpm and 700 rpm) in order to release the washing and/or additive agents. Said short spin phases may occur, for example, before or during the prewash treatment (to release the prewashing agent), and/or before or during the wash treatment (to release the washing agent), and/or before or during the rinse treatment (to release the softening agent).

The system for releasing the additive agent from the second compartment 18 is so provided as to be sensitive to the rotation speed ω of the drum 3: the additive agent is released automatically when the value of the rotation speed ω of the drum 3 exceeds a preset value ω^* . Said preset value ω^* is so determined as to be both higher than the maximum rotation speed ω_L reached during the wash treatment and lower than the rotation speed ω_C of the drum 3 during the spin treatment ($\omega^* = A \cdot \omega_L$ and $\omega^* = \omega_C / B$, wherein A and B are two coefficients being both positive and greater than 1).

A possible system for releasing the additive agent from the second compartment 18 is shown in Fig.3A and Fig.3B, which are two sectional views obtained by sectioning the lifter 9 according to a plane being orthogonal to the axis 8 of the drum 3, at the level of the second compartment 18. Fig.3A differs from Fig.3B in that Fig.3A illustrates said release system when the rotation speed ω of the drum 3 is lower than the preset value ω^* , whereas Fig.3B illustrates said release system when the rotation speed ω of the drum 3 is higher than the preset value ω^* .

During the rotation of the drum 3, the eccentricity of the lifter 9 relative to the axis of rotation represented by the axis 8 of the drum 3 remains essentially constant and is approximately equal to r, wherein r is the radius of the drum 3. It follows that a rotation speed ω produces a centrifugal acceleration of $\omega^2 \cdot r$ at the

point where the lifter 9 is secured to the drum 3. The Applicant has therefore conceived a system for releasing the additive agent from the lifter 9 which comprises a mass 20, at least two different positions of the mass 20 being possible relative to the second compartment 18, said positions comprising at least a first position and a second position: the "first position" prevents the additive agent from being released (see Fig.3A), whereas the "second position" allows the additive agent to be released (see Fig.3B).

The additive agent may leave the lifter 9 through an outlet channel 77, which is located under the second compartment 18 and communicates with the second compartment 18 through the aperture 57. It is conceivable that the first position of the mass 20 is a position wherein the mass 20, by obstructing the aperture 57, forces the additive agent to remain within the second compartment 18 (as in Fig.3A) and that the second position of the mass 20 is a position wherein the mass 20 does not prevent the additive agent from leaving the second compartment 18 (as in Fig.3B).

During the rotation of the drum 3, the mass 20, being an eccentric mass, is subject a centrifugal force $F=m.\omega^2.r$, wherein m is the mass value of the mass 20, plus the value of the mass of the additive agent possibly being present on top of the mass 20. The centrifugal force F , being dependent on the rotation speed ω , is used in order to obtain a displacement of the mass 20 from the first position to the second position when the rotation speed ω of the drum 3 reaches the preset value ω^* . The additive agent is therefore released from the second compartment 18 of the lifter 9 when the centrifugal force acting on the mass 20 exceeds the value $F^*=m.\omega^{*2}.r$. The system for releasing the additive agent from the lifter 9 also comprises a contrast spring 30, adapted to ensure that the mass 20 remains in the first position relative to the second compartment 18 until the preset value ω^* of the rotation speed ω of the drum 3 has been reached. The rigidity of the contrast spring 30 is so selected that the spring can exert a constant force being equal and opposite to F^* on the mass 20, when the mass 20 is in its first position. In this way, the mass 20 only moves to the second position relative to the second compartment 18 when the centrifugal force F becomes greater than F^* (preferably at the beginning of the spin treatment), thus allowing the additive agent to leave

the lifter 9.

According to the present invention, by using the basic principle of the release system shown in Fig.3A and Fig.3B it is possible to provide selective dispensing devices containing several washing and/or additive agents. In fact, for example, it is conceivable to provide a first container compartment associated with a first release system, designed to dispense a first agent when the rotation speed of the drum exceeds a first rotation speed value (e.g. 300-400 rpm), and a second container compartment associated with a second release system, designed to dispense a second agent when the rotation speed of the drum exceeds a second rotation speed value (e.g. 500-700 rpm); the first and the second values are different and may be determined simply through an appropriate choice of, for example, the rigidity of the springs and/or the mass value of the displaceable masses; the first agent is to be chosen for being dispensed before the second agent.

Of course, the above-described solution may be extended with a greater number of compartments, e.g. three or four; moreover, this solution combines particularly well with the idea of using spin phases, preferably short spin phases, adapted to release washing and/or additive agents.

As an alternative to the outlet channel 77, it is conceivable that the release of the additive agent from the lifter 9 takes place as a result of a rotation of the second compartment 18 about a hinge axis, said rotation being caused by the displacement of the mass 20 from the first position to the second position relative to the second compartment 18. Also, it is conceivable that the release of the additive agent takes place through the very same section used for loading the additive agent into the lifter 9, i.e. through the inlet section 54. In this case, the first position of the mass 20 is a position wherein the mass 20 forces the lid 19 to remain closed, while the second position is a position wherein the mass 20 does not prevent the lid 19 from opening freely, thus allowing the additive agent to leave the second compartment 18 through the inlet section 54.

In a household appliance according to the present invention, the washing and/or additive agents may also be dispensed, at least partially, through thermal and/or electric actuators; the use of a small electronic unit for controlling the

-10-

distribution of the washing and/or additive agents should also be considered; these components, like any electric power sources (such as batteries or accumulators) will typically be comprised in the lifter 9.

5 The present invention, which clearly overcomes the aforementioned inherent drawbacks of those household appliances comprising a drawer-type washing agent dispenser and a dedicated hydraulic circuit for washing away the washing agents to the tub, has been described by the Applicant with reference to a particular embodiment example, but it is apparent that many variants of the present invention are possible for those skilled in the art and that all said variants
10 still fall within the scope defined by the appended claims.

CLAIMS

1. Household appliance (1), in particular adapted to carry out at least one wash treatment on textile items, comprising a rotating drum (3) adapted to contain the textile items to be treated, and at least one element (9) adapted to drag and/or lift the textile items during the treatment, characterized in that said element (9) comprises means adapted to contain washing and/or additive agents.
2. Appliance (1) according to claim 1, wherein said element (9) is secured to said drum (3) in such a way as to be adjacent to the inner face of said drum (3), in particular to the inner face of the surface of said drum (3).
3. Appliance (1) according to claim 1 or 2, wherein said element (9) is made of plastic material.
4. Appliance (1) according to claim 3, wherein said element (9) is coated with a layer of a soft and/or elastic material.
5. Appliance (1) according to claim 1 or 2 or 3 or 4, wherein said element (9) comprises at least one part being detachable from said drum (3).
6. Appliance (1) according to any of the preceding claims, wherein said element (9) is removably connected to said drum (3).
7. Appliance (1) according to any of the preceding claims, wherein said element (9) comprises a first compartment (12), adapted to contain in particular a washing agent, and a second compartment (18), adapted to contain in particular an additive agent.
8. Appliance (1) according to claim 7, wherein said washing agent is a detergent in powder, or a detergent in tablets, or a liquid detergent.
9. Appliance (1) according to claim 7 or 8, wherein said additive agent is a liquid softener or bleach.
10. Appliance (1) according to claim 7 or 8 or 9, wherein said element (9) comprises means for loading said washing agent into said first compartment (12) and/or said additive agent into said second compartment (18), said loading means preferably comprising at least one slot (15) and/or at least one lid (19).
11. Appliance (1) according to any of the preceding claims, wherein said element (9) comprises at least one system for releasing a washing and/or additive agent, which system is sensitive to the rotation speed (ω) of said drum (3).

12. Appliance (1) according to claim 11, wherein said release system is so provided that said washing and/or additive agent is released automatically when the value of the rotation speed of said drum (3) exceeds a preset value (ϖ^*).

13. Appliance (1) according to any of claims 7 to 10 and according to claim 11 or 5 12, of the type adapted also to carry out at least one spin phase, characterized in that said release system is adapted to release an agent from said first and/or said second compartment during said spin phase.

14. Appliance (1) according to claim 11 or 12 or 13, wherein said release system comprises a mass (20), said mass (20) being able to take at least two different 10 positions, said at least two different positions comprising a first and a second position, said first position being such as to prevent said agent from being released and said second position being such as to allow said agent to be released.

15. Appliance (1) according to claim 14, wherein said release system also 15 comprises a contrast spring (30), adapted to ensure that said mass (20) remains in said first position until said preset value (ϖ^*) of the rotation speed (ϖ) of said drum (3) has been reached.

1 / 3

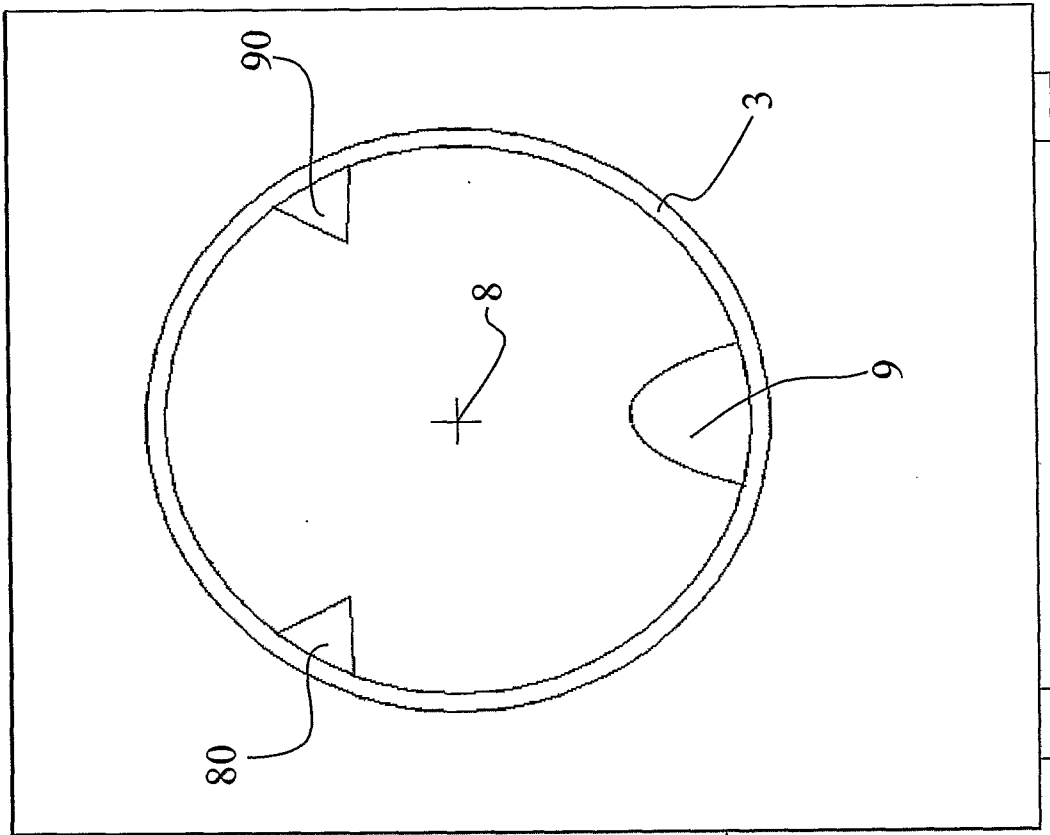

Fig.1



10

2 / 3

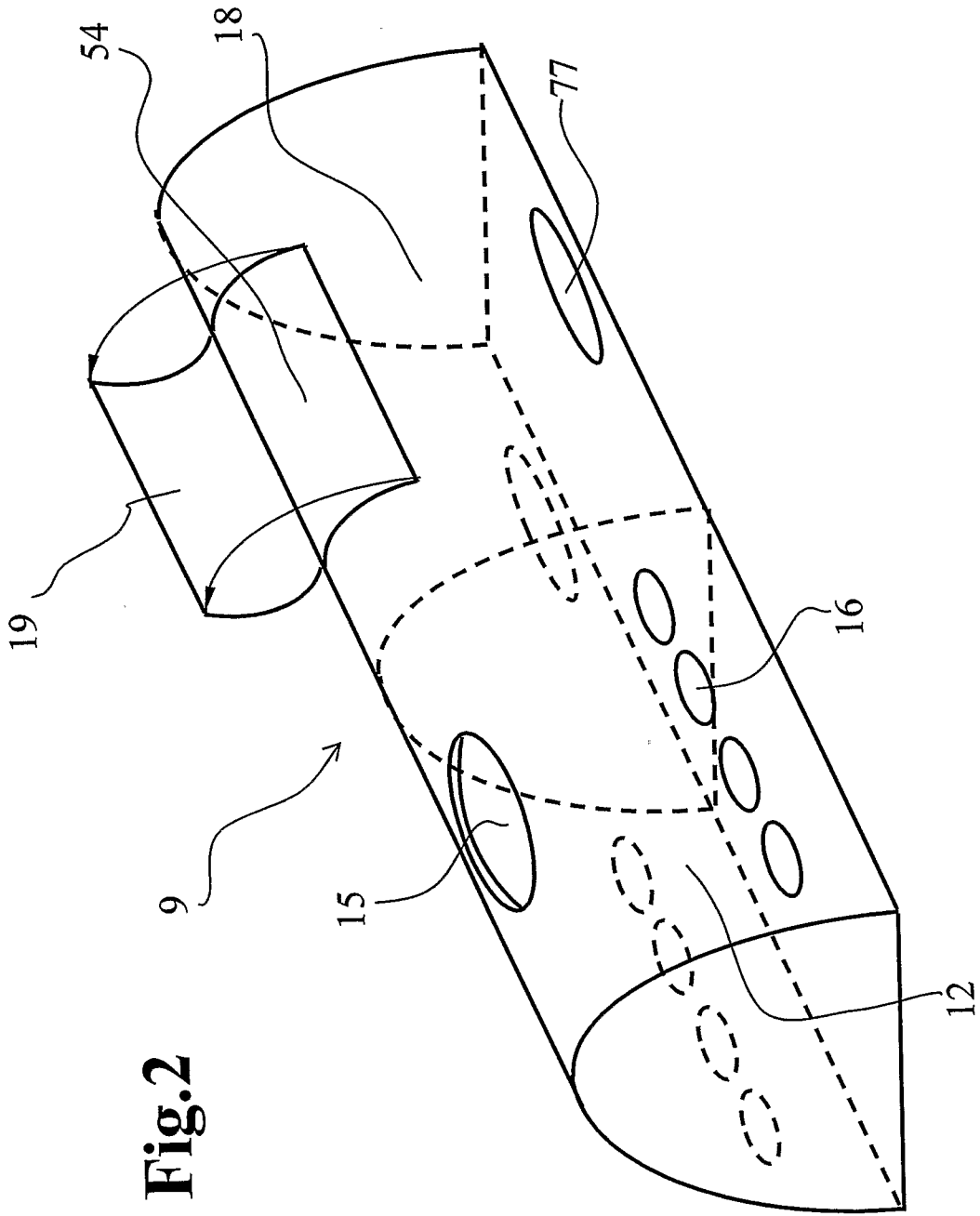

Fig. 2

Fig.3B

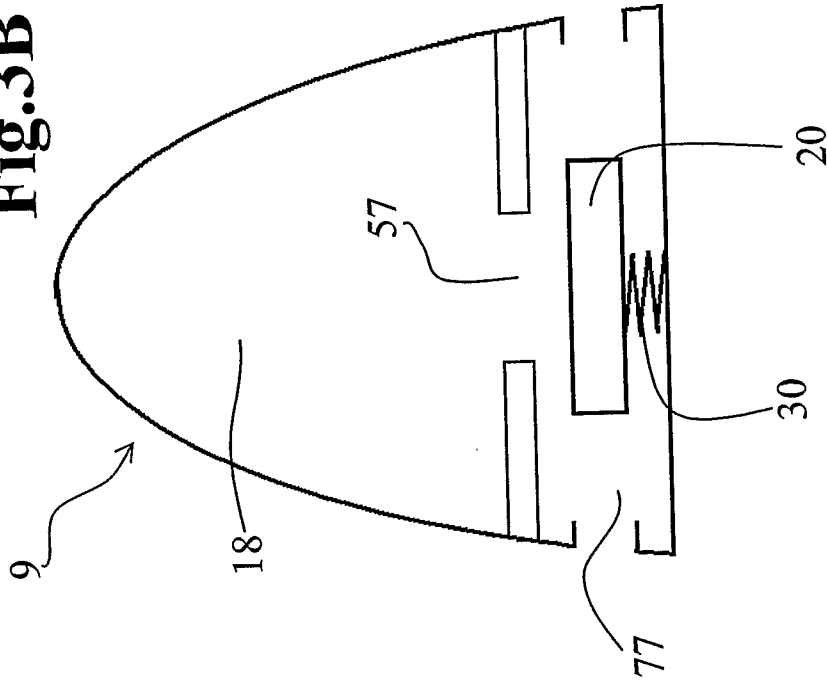
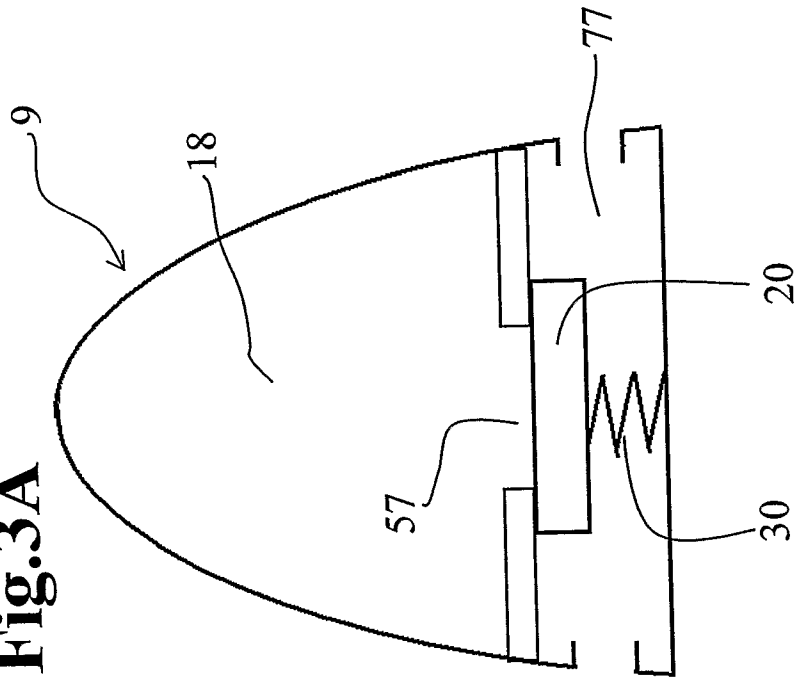

Fig.3A



INTERNATIONAL SEARCH REPORT

International application No
PCT/IB2006/002630

A. CLASSIFICATION OF SUBJECT MATTER INV. D06F37/06 D06F39/02				
According to International Patent Classification (IPC) or to both national classification and IPC				
B. FIELDS SEARCHED				
Minimum documentation searched (classification system followed by classification symbols) D06F				
Documentation searched other than minimum documentation to the extent that such documents are included in the fields searched				
Electronic data base consulted during the international search (name of data base and, where practical, search terms used) EPO-Internal				
C. DOCUMENTS CONSIDERED TO BE RELEVANT				
Category*	Citation of document, with indication, where appropriate, of the relevant passages	Relevant to claim No.		
X	EP 0 351 671 A (HENKEL KGAA [DE]) 24 January 1990 (1990-01-24) column 8, line 2 - column 13, line 38; figures	1-10		
P, X	EP 1 690 974 A (ELECTROLUX HOME PROD CORP [BE]) 16 August 2006 (2006-08-16) column 2, paragraph 7 - column 3, paragraph 14; figures 1-2b	1-10		
X	EP 0 503 999 A1 (CIAPEM [FR]) 16 September 1992 (1992-09-16) column 2, line 23 - column 7, line 54; figures	1-4, 7-10		
X	US 3 701 202 A1 (COMPA RUSSEL EDWARD ET AL) 31 October 1972 (1972-10-31) the whole document	1-6, 8, 10		
<input type="checkbox"/> Further documents are listed in the continuation of Box C. <input checked="" type="checkbox"/> See patent family annex.				
* Special categories of cited documents :				
<table style="width:100%; border:none;"> <tr> <td style="width:50%; vertical-align: top;"> *A* document defining the general state of the art which is not considered to be of particular relevance *E* earlier document but published on or after the international filing date *L* document which may throw doubts on priority claim(s) or which is cited to establish the publication date of another citation or other special reason (as specified) *O* document referring to an oral disclosure, use, exhibition or other means *P* document published prior to the international filing date but later than the priority date claimed </td> <td style="width:50%; vertical-align: top;"> *T* later document published after the international filing date or priority date and not in conflict with the application but cited to understand the principle or theory underlying the invention *X* document of particular relevance; the claimed invention cannot be considered novel or cannot be considered to involve an inventive step when the document is taken alone *Y* document of particular relevance; the claimed invention cannot be considered to involve an inventive step when the document is combined with one or more other such documents, such combination being obvious to a person skilled in the art. *Z* document member of the same patent family </td> </tr> </table>			*A* document defining the general state of the art which is not considered to be of particular relevance *E* earlier document but published on or after the international filing date *L* document which may throw doubts on priority claim(s) or which is cited to establish the publication date of another citation or other special reason (as specified) *O* document referring to an oral disclosure, use, exhibition or other means *P* document published prior to the international filing date but later than the priority date claimed	*T* later document published after the international filing date or priority date and not in conflict with the application but cited to understand the principle or theory underlying the invention *X* document of particular relevance; the claimed invention cannot be considered novel or cannot be considered to involve an inventive step when the document is taken alone *Y* document of particular relevance; the claimed invention cannot be considered to involve an inventive step when the document is combined with one or more other such documents, such combination being obvious to a person skilled in the art. *Z* document member of the same patent family
A document defining the general state of the art which is not considered to be of particular relevance *E* earlier document but published on or after the international filing date *L* document which may throw doubts on priority claim(s) or which is cited to establish the publication date of another citation or other special reason (as specified) *O* document referring to an oral disclosure, use, exhibition or other means *P* document published prior to the international filing date but later than the priority date claimed	*T* later document published after the international filing date or priority date and not in conflict with the application but cited to understand the principle or theory underlying the invention *X* document of particular relevance; the claimed invention cannot be considered novel or cannot be considered to involve an inventive step when the document is taken alone *Y* document of particular relevance; the claimed invention cannot be considered to involve an inventive step when the document is combined with one or more other such documents, such combination being obvious to a person skilled in the art. *Z* document member of the same patent family			
Date of the actual completion of the international search <p align="center">21 February 2007</p>		Date of mailing of the international search report <p align="center">07/03/2007</p>		
Name and mailing address of the ISA/ European Patent Office, P.B. 5818 Patentlaan 2 NL - 2280 HV Rijswijk Tel. (+31-70) 340-2040, Tx. 31 651 epo nl, Fax: (+31-70) 340-3016		Authorized officer <p align="center">Lodato, Alessandra</p>		

INTERNATIONAL SEARCH REPORT

Information on patent family members

International application No

PCT/IB2006/002630

Patent document cited in search report	A	Publication date	Patent family member(s)	Publication date
EP 0351671	A	24-01-1990	DE 3824183 A1 DE 8816711 U1 WO 9000641 A1 ES 1011096 U1 PT 91180 A	25-01-1990 12-04-1990 25-01-1990 01-03-1990 08-02-1990
EP 1690974	A	16-08-2006	NONE	
EP 0503999	A1	16-09-1992	DE 69203631 D1 FR 2673648 A1	31-08-1995 11-09-1992
US 3701202	A1		NONE	