



US 20130041331A1

(19) **United States**

(12) **Patent Application Publication**
Overstreet et al.

(10) **Pub. No.: US 2013/0041331 A1**

(43) **Pub. Date: Feb. 14, 2013**

(54) **MODULAR DRUG DELIVERY SYSTEM FOR MINIMIZING TRAUMA DURING AND AFTER INSERTION OF A COCHLEAR LEAD**

continuation-in-part of application No. 12/202,134, filed on Aug. 29, 2008, now Pat. No. 8,190,271.

(60) Provisional application No. 60/968,785, filed on Aug. 29, 2007.

(75) Inventors: **Edward H. Overstreet**, Valencia, CA (US); **Jian Xie**, Stevenson Ranch, CA (US); **Michael S. Colvin**, Thousand Oaks, CA (US); **Michael A. Faltys**, Valencia, CA (US)

Publication Classification

(51) **Int. Cl.**
A61M 5/00 (2006.01)
(52) **U.S. Cl.** **604/285**

(73) Assignee: **ADVANCED BIONICS, LLC**, Valencia, CA (US)

(57) **ABSTRACT**

(21) Appl. No.: **13/588,837**

A system for delivering a therapeutic agent to biological tissue includes a surgically implantable lead to be inserted into the biological tissue. The surgically implantable lead includes a preformed cavity. A modular capsule is configured to be retained within the preformed cavity. The modular capsule includes a first therapeutic agent and a second therapeutic agent, wherein the first therapeutic agent elutes rapidly into the biological tissue and the second therapeutic agent elutes more slowly into the biological tissue.

(22) Filed: **Aug. 17, 2012**

Related U.S. Application Data

(63) Continuation of application No. 12/533,963, filed on Jul. 31, 2009, now Pat. No. 8,271,101, which is a

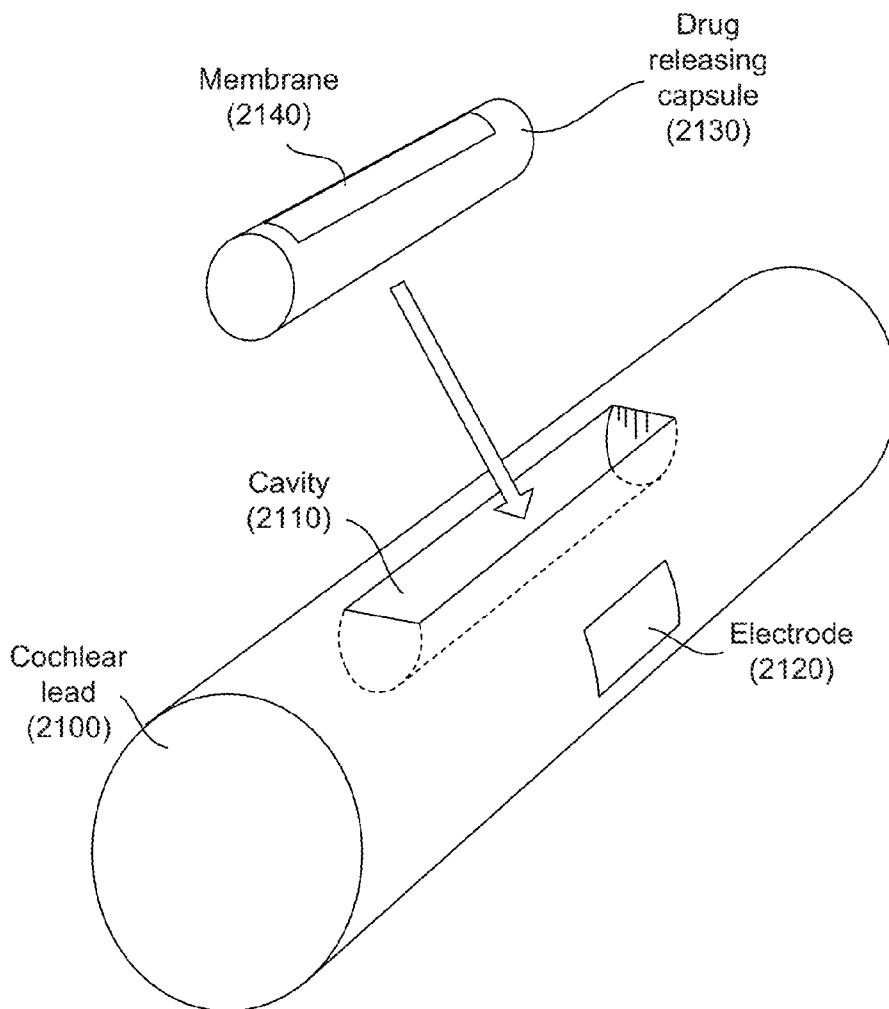

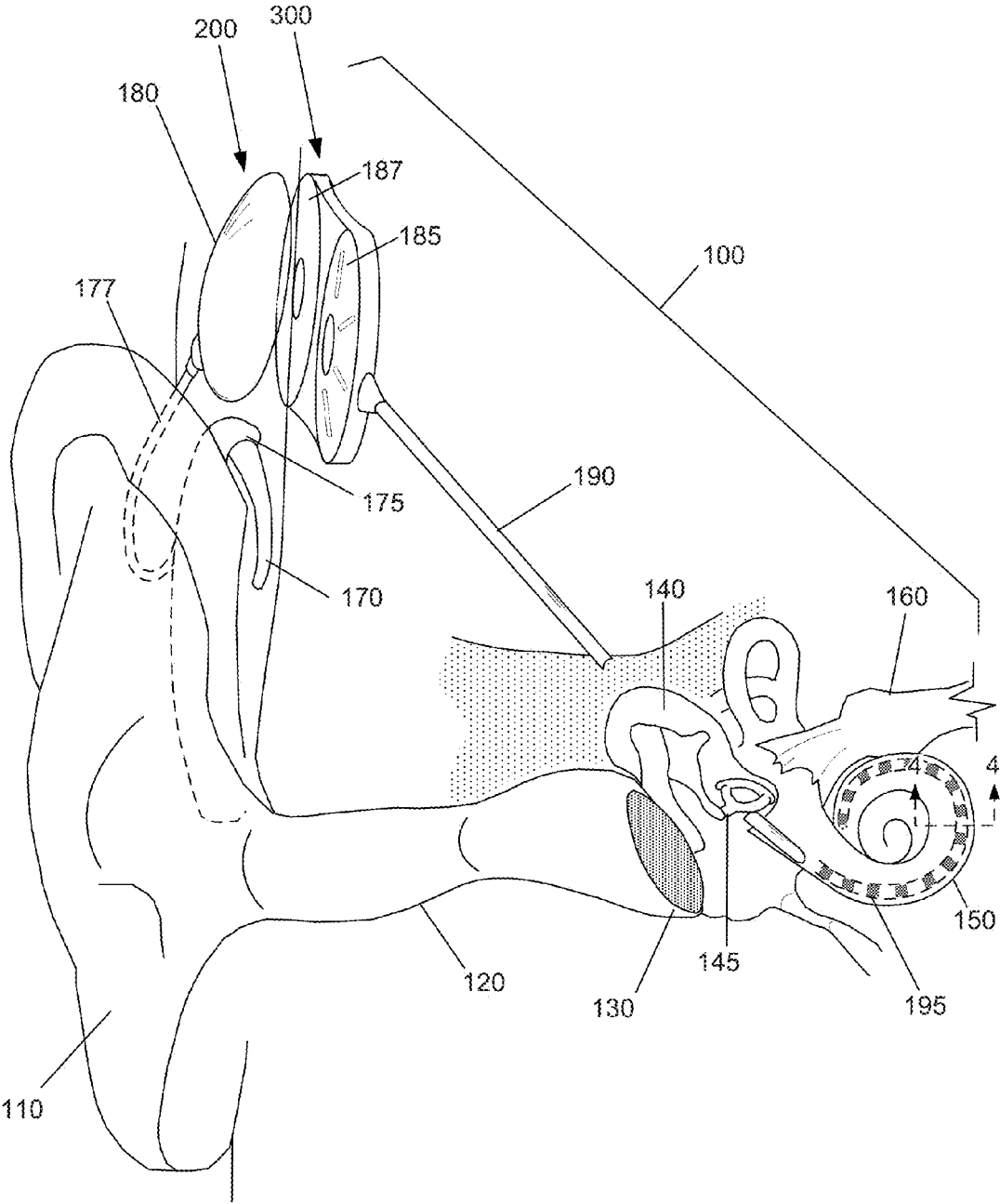

Fig. 1

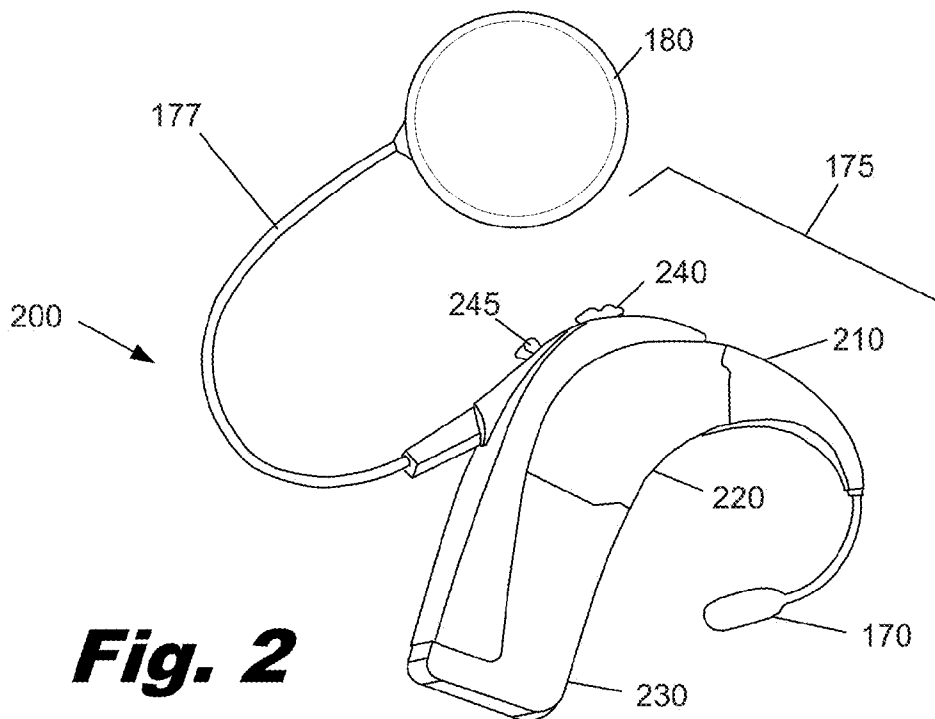

Fig. 2

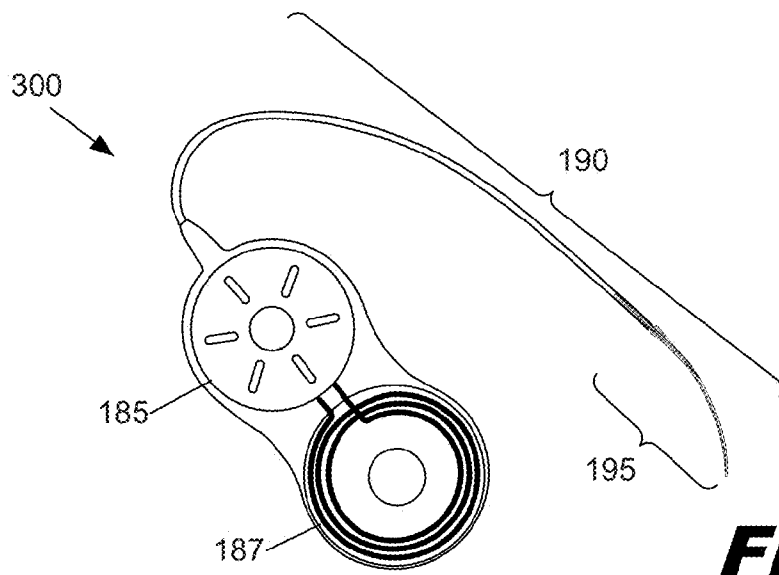

Fig. 3

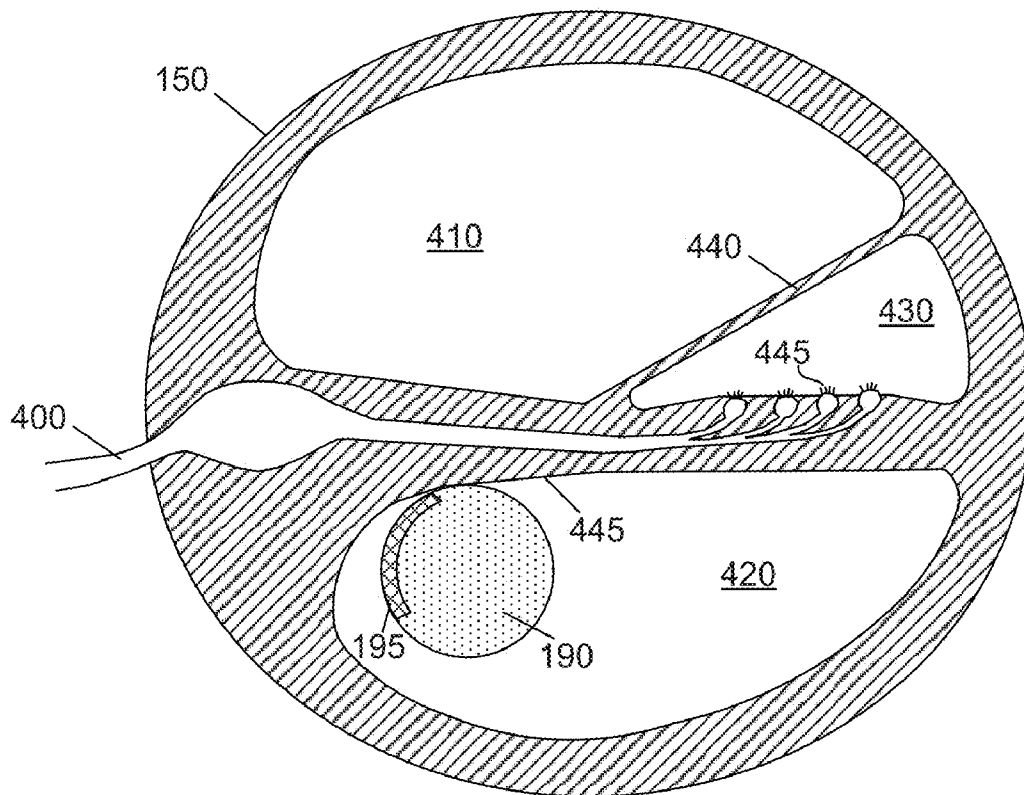

Fig. 4

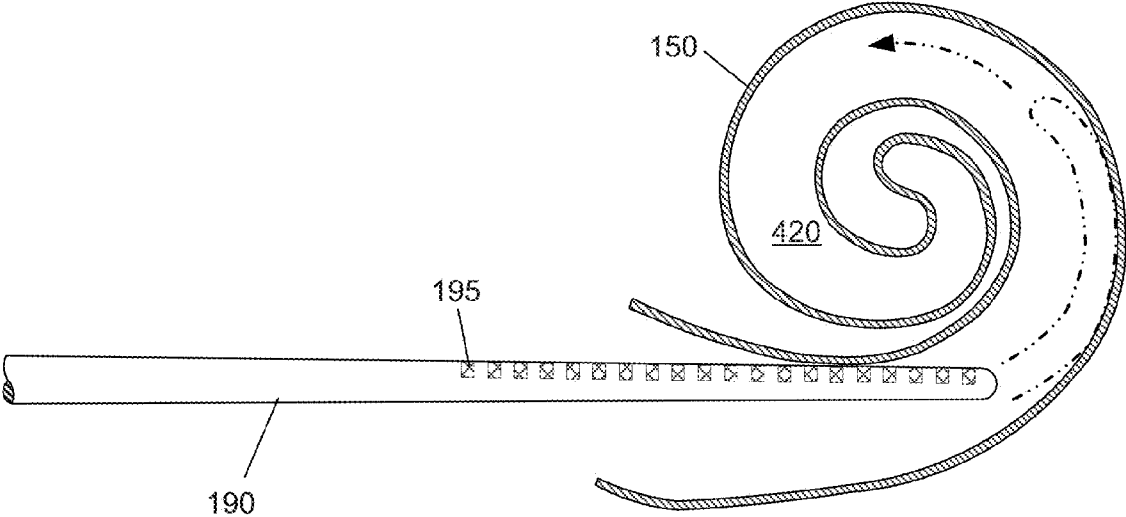

Fig. 5

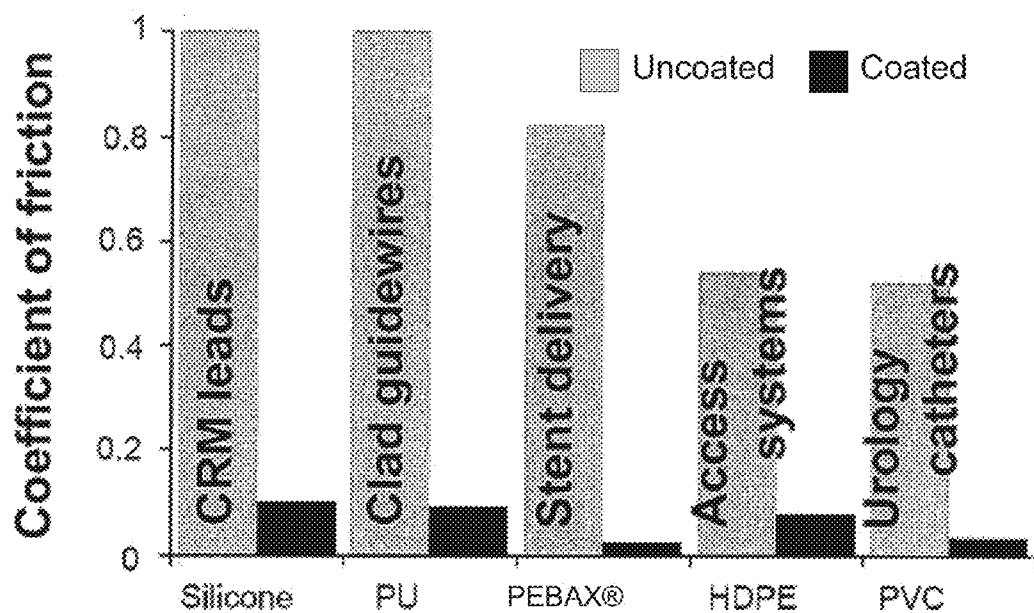

Fig. 6

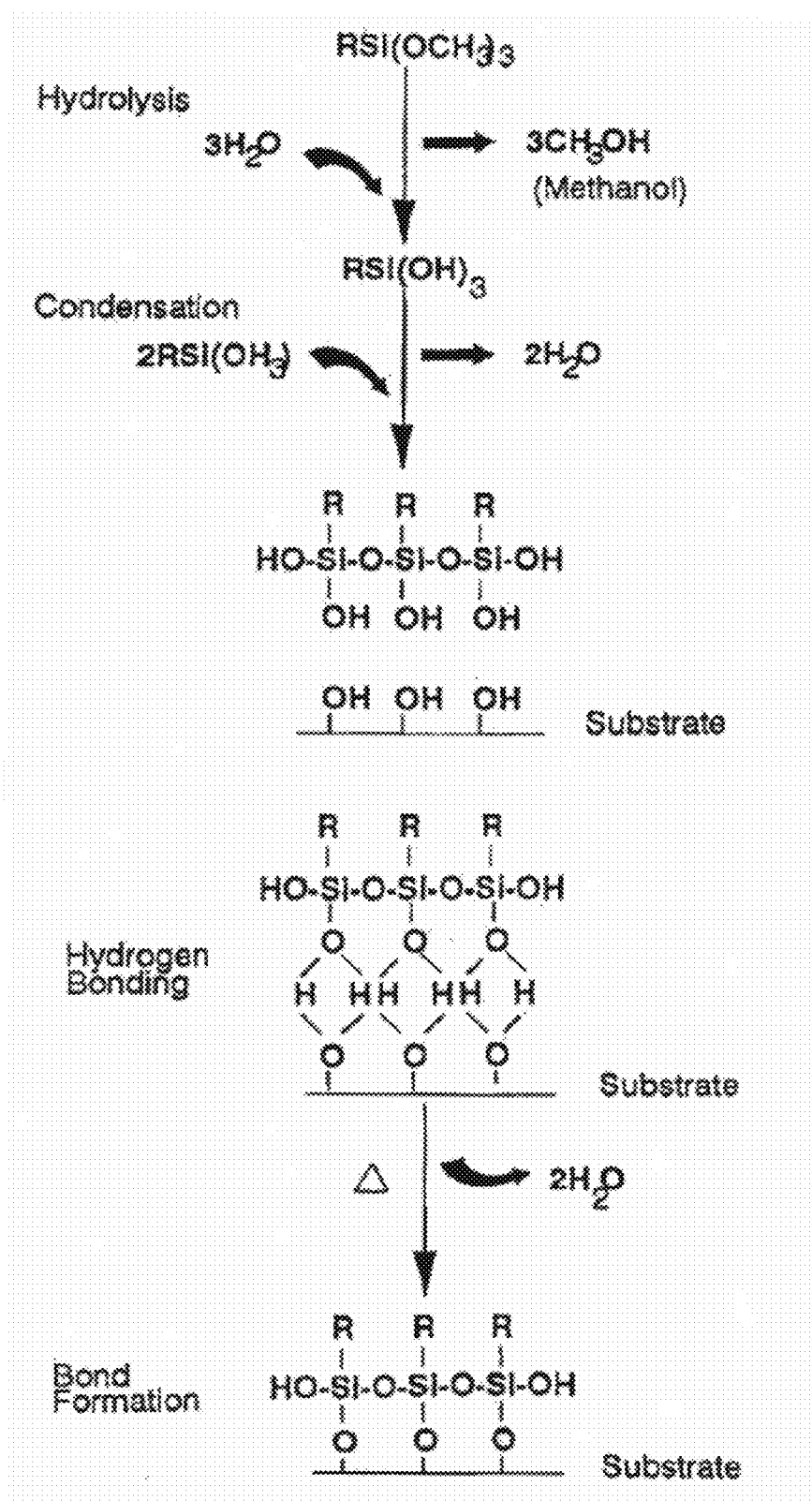

Fig. 7

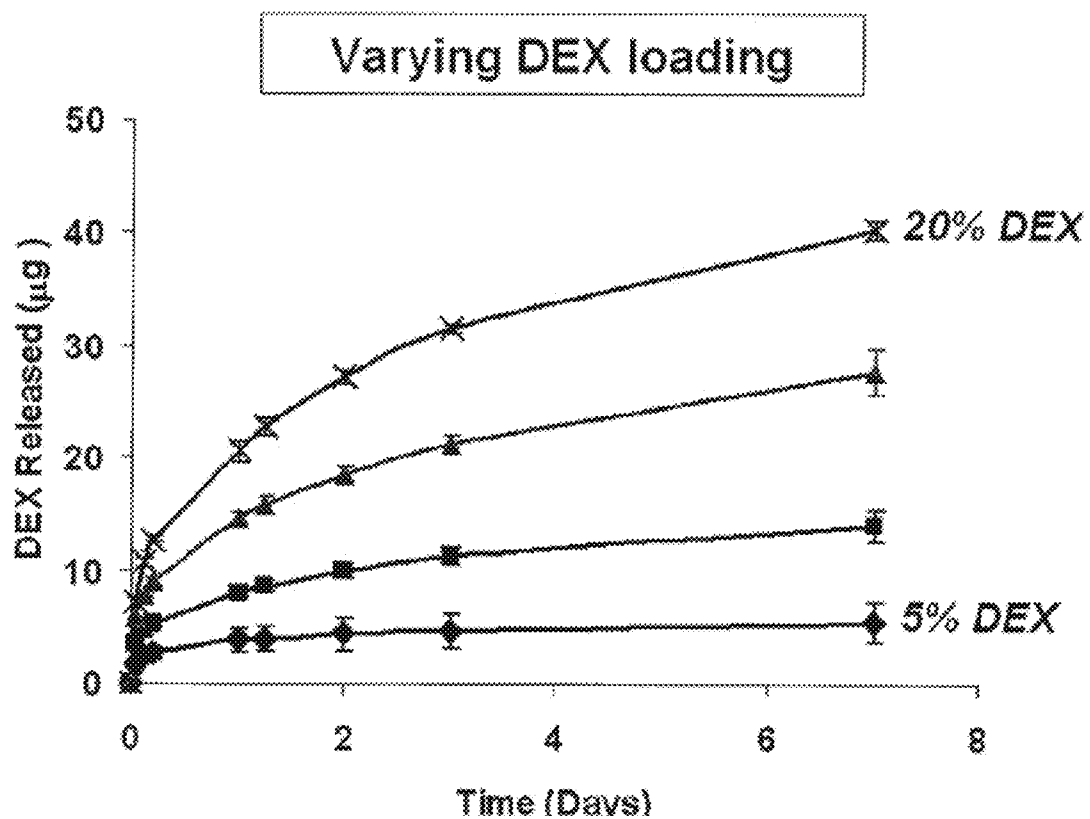

Fig. 8

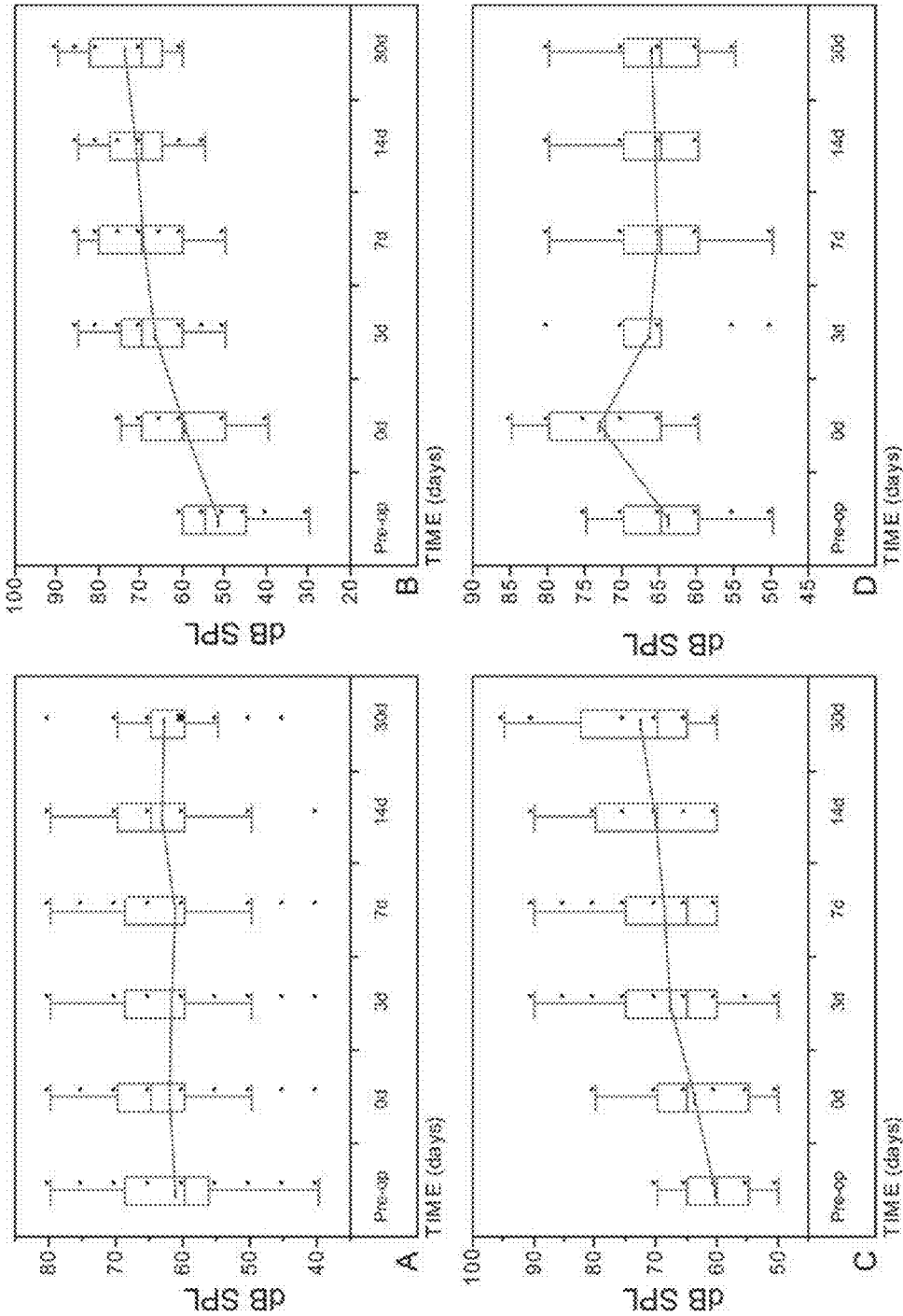

Fig. 9

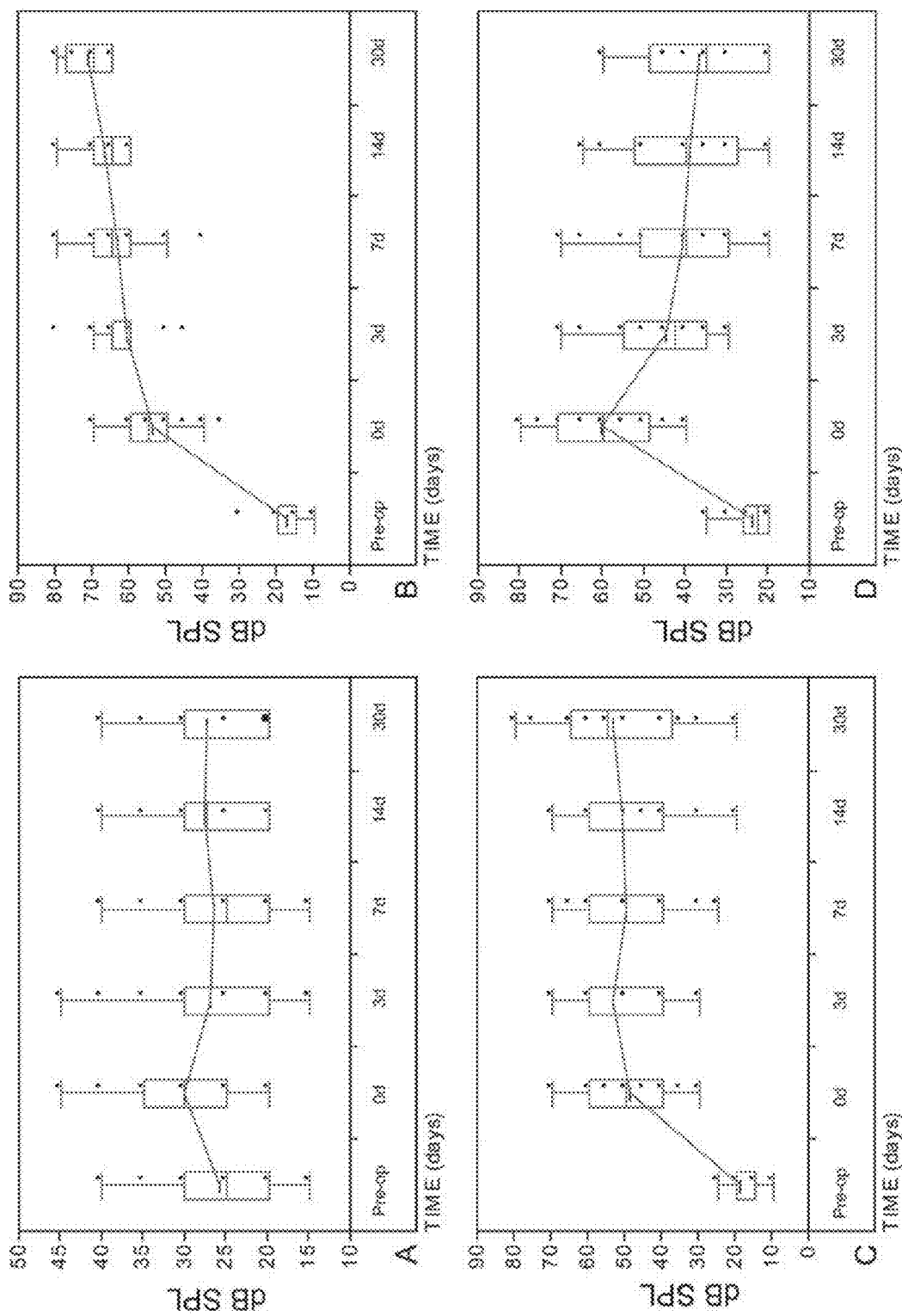

Fig. 10

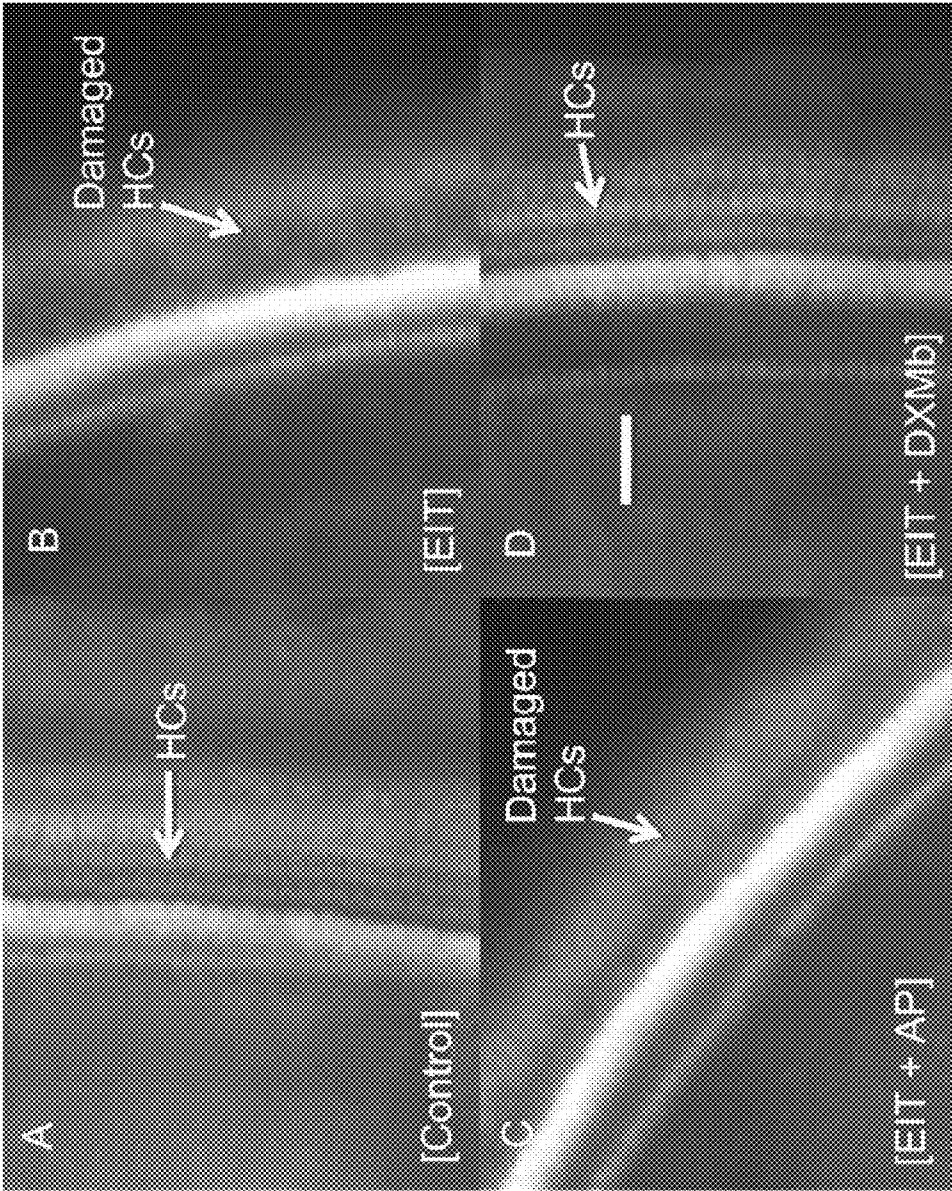

Fig. 11

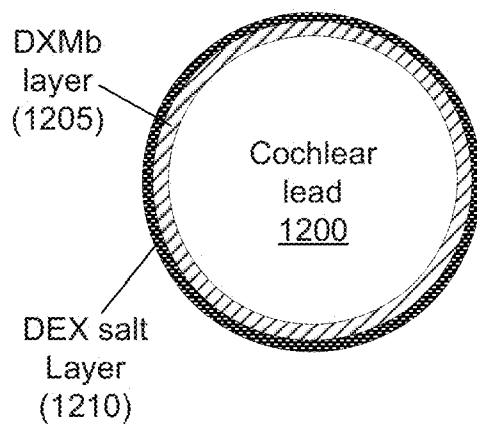

Fig. 12

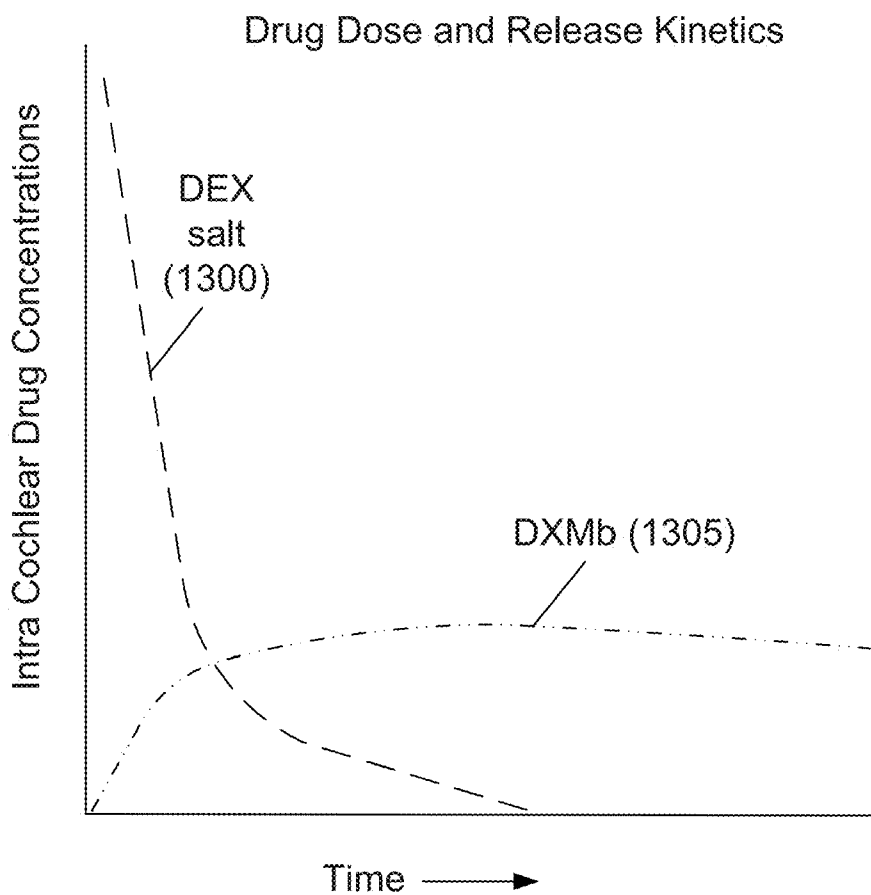

Fig. 13

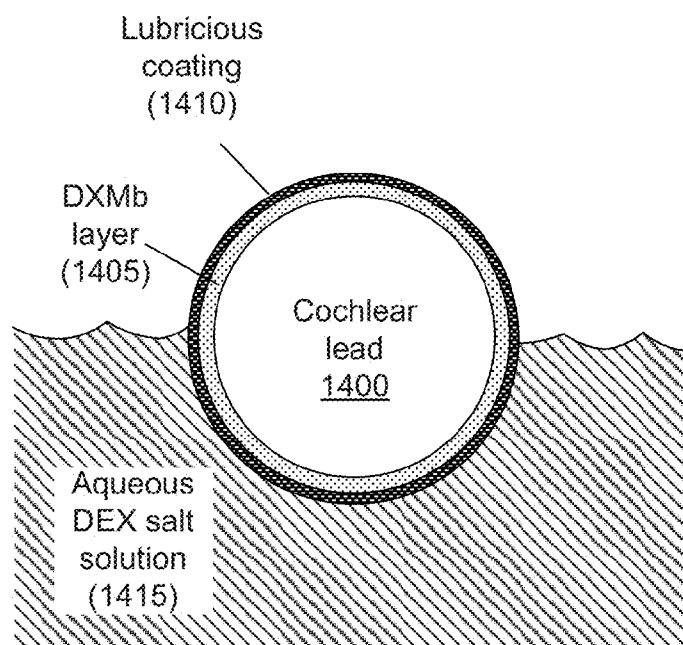

Fig. 14A

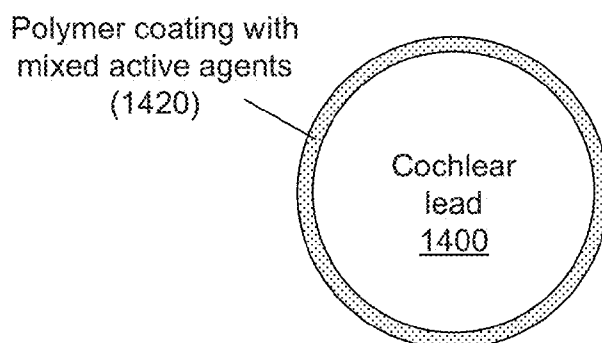

Fig. 14B

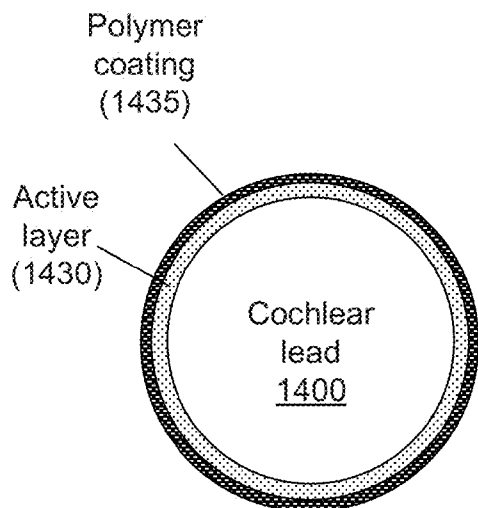

Fig. 14C

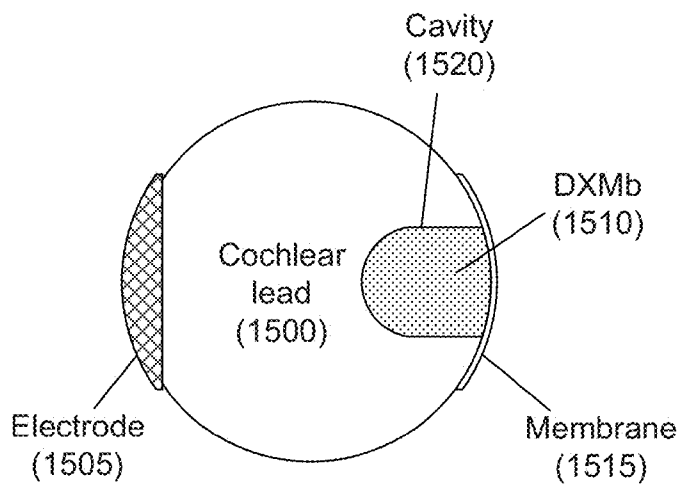

Fig. 15

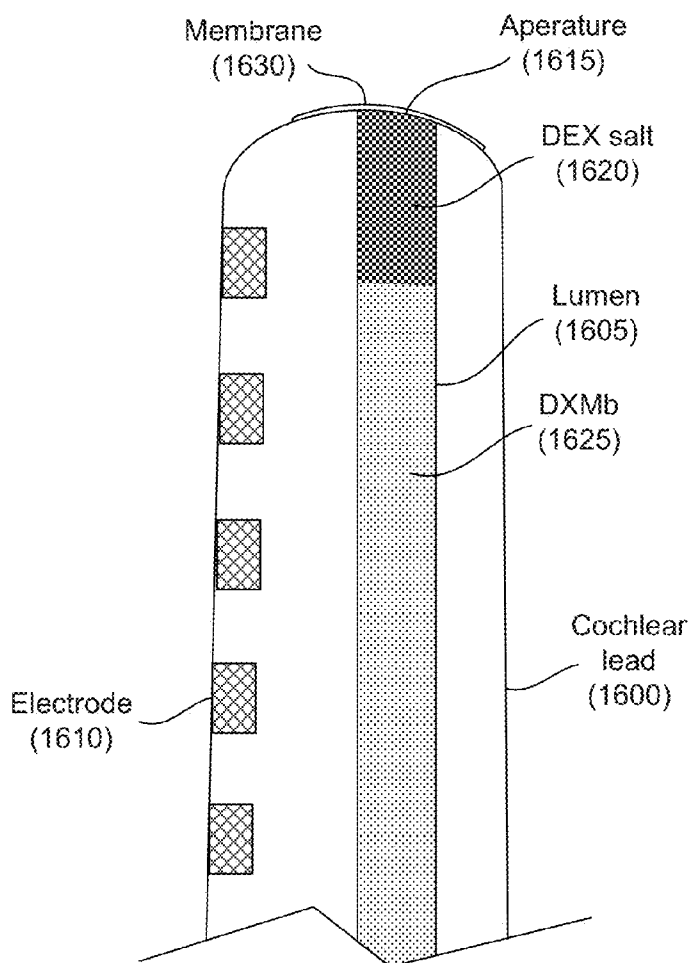

Fig. 16

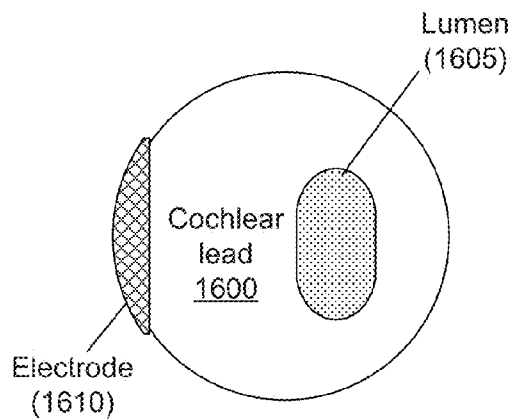

Fig. 17

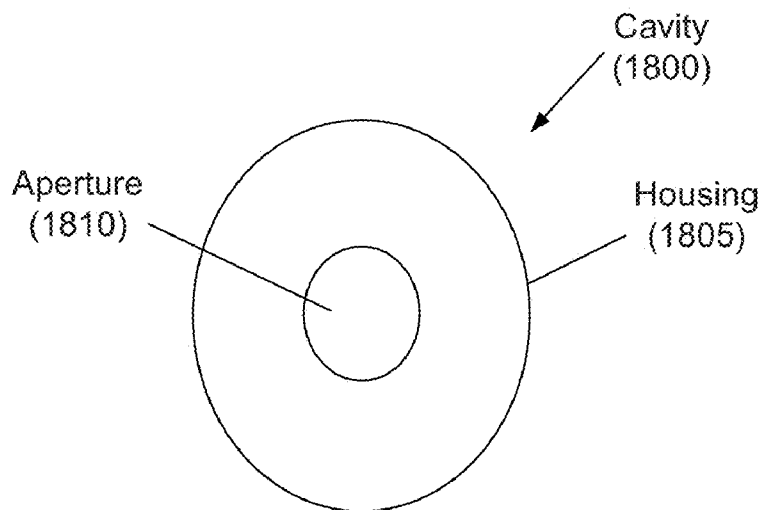

Fig. 18A

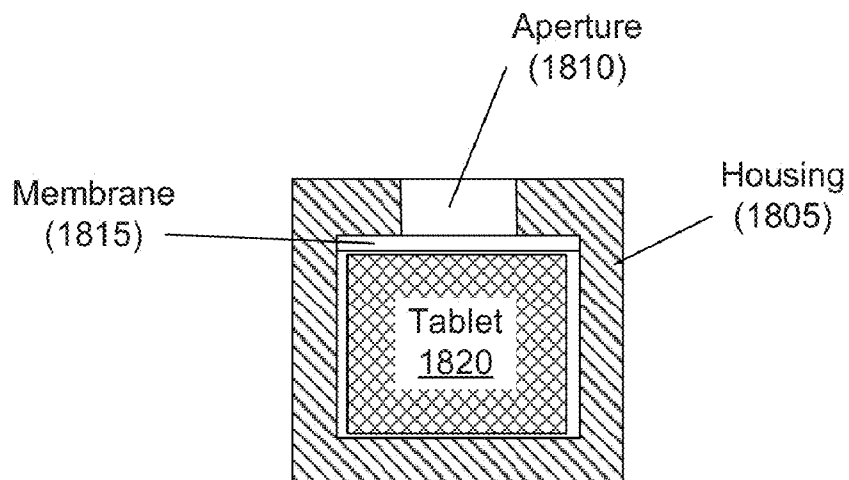

Fig. 18B

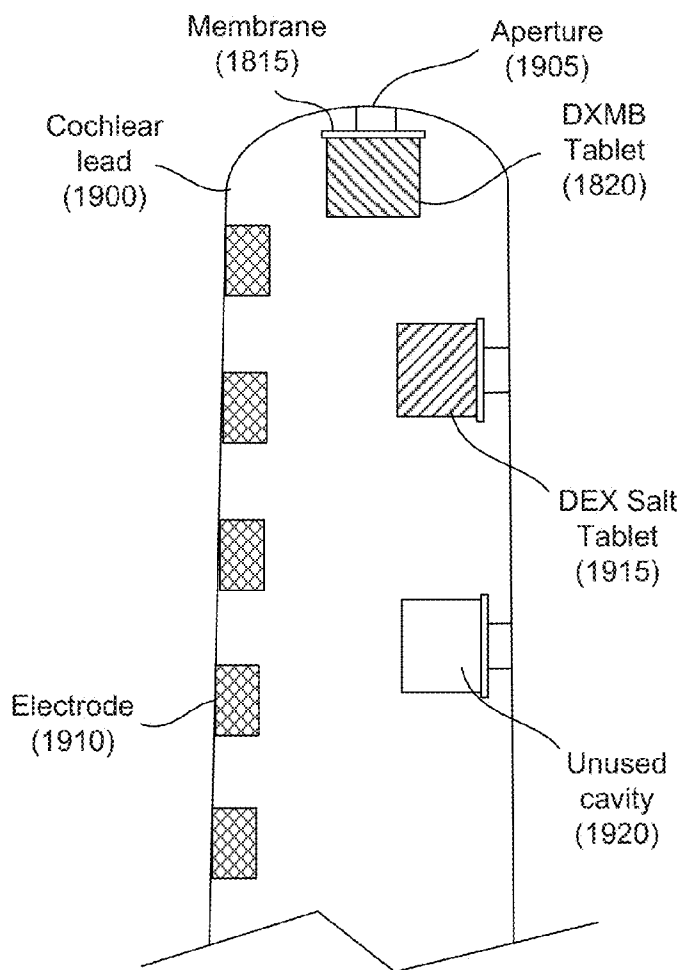

Fig. 19

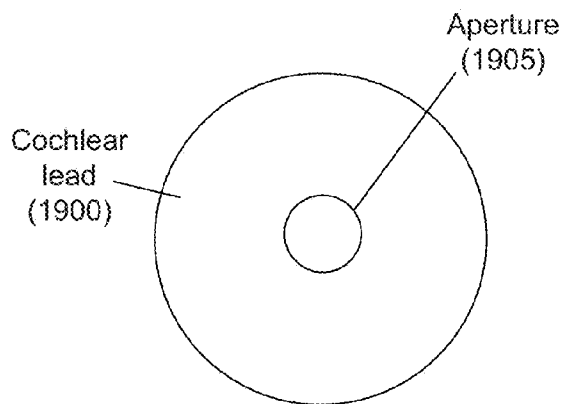

Fig. 20

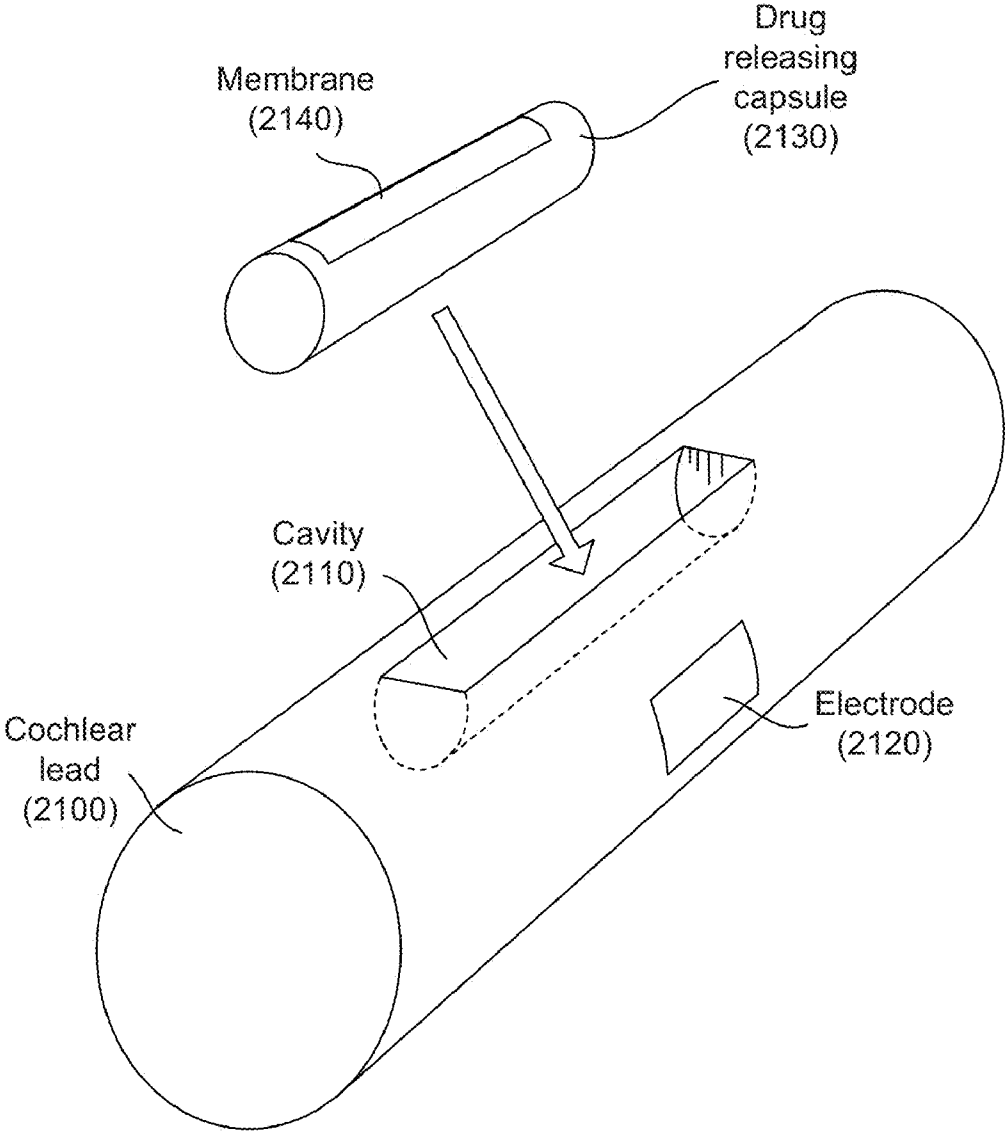

Fig. 21

**MODULAR DRUG DELIVERY SYSTEM FOR
MINIMIZING TRAUMA DURING AND AFTER
INSERTION OF A COCHLEAR LEAD**

RELATED APPLICATIONS

[0001] The present application is a continuation and claims the benefit under 35 U.S.C. §120, of U.S. patent application Ser. No. 12/533,963, filed Jul. 31, 2009, which claims priority to under 35 U.S.C. §120, of U.S. patent application Ser. No. 12/202,134, filed Aug. 29, 2008, now issued as U.S. Pat. No. 8,190,271, which claims priority under 35 U.S.C. §119(e) to U.S. Provisional Patent Application No. 60/968,785, filed on Aug. 29, 2007. These applications are herein incorporated by reference in their entireties.

BACKGROUND

[0002] A cochlear implant is a surgically implanted electronic device that resides in the cochlea of a patient's ear and provides a sense of sound to the patient who is profoundly deaf or severely hard of hearing. The present specification relates to such neural stimulators and, particularly, to cochlear implant systems that include electrode arrays for stimulation of a patient's cochlea. In a typical cochlear implant, an array of electrode contacts are placed along one side of an elongate carrier or lead so that when the array is implanted within one of the cochlear ducts, such as the scala tympani, the electrode contacts are positioned in close proximity to the cells that are to be stimulated. This allows such cells to be stimulated with minimal power consumption.

[0003] To maximize the benefit of the surgery for the patient, it is important to preserve the residual hearing of the patient and to maximize the long term effectiveness of the cochlear implant. As the cochlear lead is inserted through the tissues in the head and into the cochlea, there can be mechanical damage to the surrounding tissues, subsequent inflammation, and possibly damage to the delicate structures within the cochlea. Additionally, various autoimmune reactions can occur in response to the presence of the cochlear lead in the cochlea. These autoimmune reactions can include growth of tissue around the cochlear implant and eventual ossification. This tissue growth can act as a barrier between the electrodes of the cochlear implant and the target nerves. This can lead to a degradation of the performance of the cochlear implant over time.

BRIEF DESCRIPTION OF THE DRAWINGS

[0004] The accompanying drawings illustrate various embodiments of the principles described herein and are a part of the specification. The illustrated embodiments are merely examples and do not limit the scope of the claims.

[0005] FIG. 1 is an illustrative diagram showing a cochlear implant system in use, according to one embodiment of principles described herein.

[0006] FIG. 2 is a diagram showing external components of an illustrative cochlear implant system, according to one embodiment of principles described herein.

[0007] FIG. 3 is a diagram showing the internal components of an illustrative cochlear implant system, according to one embodiment of principles described herein.

[0008] FIG. 4 is an illustrative cross-sectional diagram of the cochlea showing the insertion location of the intra cochlear lead, according to one embodiment of principles described herein.

[0009] FIG. 5 is an illustrative diagram of the insertion of the terminal portion of an intra cochlear lead into the cochlea, according to one embodiment of principles described herein.

[0010] FIG. 6 is an illustrative diagram of representative coefficients of friction for various coatings commonly used on surgical devices, according to one embodiment of principles described herein.

[0011] FIG. 7 is an illustrative diagram illustrating a series of chemical reactions of silanes with silicone, according to one embodiment of the principles described herein.

[0012] FIG. 8 is an illustrative chart showing the release of a steroid from a polymer coating, according to one embodiment of principles described herein.

[0013] FIG. 9 is a graph which illustrates the effectiveness of dexamethasone base (DXMb) steroid in minimizing surgery induced hearing loss, according to one embodiment of principles described herein.

[0014] FIG. 10 is a graph which illustrates the effectiveness of DXMb steroid in minimizing surgery induced hearing loss, according to one embodiment of principles described herein.

[0015] FIG. 11 shows the efficacy of DXMb protecting the auditory hair cells from electrode insertion trauma, according to one embodiment of principles described herein.

[0016] FIG. 12 is a cross-sectional diagram of one illustrative cochlear lead with various coatings, according to one embodiment of principles described herein.

[0017] FIG. 13 is an illustrative graph of drug dose and release kinetics, according to one embodiment of principles described herein.

[0018] FIGS. 14A-14C are cross-sectional diagrams of an illustrative cochlear lead with various coatings, according to one embodiment of principles described herein.

[0019] FIG. 15 is a cross-sectional diagram of an illustrative cochlear lead with a cavity containing DXMb, according to one embodiment of principles described herein.

[0020] FIG. 16 is a longitudinal section of an illustrative cochlear lead with a longitudinal lumen configured to accept various drug compounds, according to one embodiment of principles described herein.

[0021] FIG. 17 is a cross-sectional diagram of illustrative cochlear lead with a longitudinal lumen configured to accept various drug compounds, according to one embodiment of principles described herein.

[0022] FIGS. 18A and 18B are a top view and a cross-sectional diagram, respectively, of illustrative dispensing mechanism for pharmaceutical agents, according to one embodiment of principles described herein.

[0023] FIG. 19 is a cross-sectional diagram of illustrative cochlear lead with an illustrative dispensing mechanism for pharmaceutical agents, according to one embodiment of principles described herein.

[0024] FIG. 20 is a top view of an illustrative cochlear lead with an illustrative dispensing mechanism for pharmaceutical agents, according to one embodiment of principles described herein.

[0025] FIG. 21 is a perspective view of an illustrative drug releasing capsule and cochlear lead adapted to receive the capsule, according to one embodiment of principles described herein.

[0026] Throughout the drawings, identical reference numbers designate similar, but not necessarily identical, elements.

DETAILED DESCRIPTION

[0027] To place a cochlear implant, the terminal portion of a cochlear lead is pushed through an opening into the cochlea. The terminal portion of the lead is typically constructed out of biocompatible silicone. This gives the terminal portion of the lead the flexibility to curve around the helical interior of the cochlea. However, silicone has a high coefficient of friction and requires that a relatively high axial force be applied along the cochlear lead during the insertion process. As a result, the silicone can mechanically abrade or otherwise damage the interior of the cochlea, which can cause inflammation and disturbance of the vestibular duct or other structures, leading to nerve damage, vertigo, and/or tinnitus. Additionally, autoimmune reactions can cause nerve damage and undesirable tissue growth within the cochlea. This can result in the encapsulation of the cochlear lead by a layer of fibrotic tissue, which insulates the cochlear lead from the remaining nerve cells and further reduces the effectiveness of applied voltages.

[0028] As a consequence of this potential for damage to the residual hearing of a patient and reduction of efficiency of the cochlear lead over time, the majority of patients who are considered for cochlear implants have severe or total hearing loss. For this group of patients, the benefits provided by the cochlear implant can outweigh the risk of residual hearing loss. However, by solving the problems described above, cochlear implants could improve the hearing and quality of life of a much broader range of patients. Particularly, as a surgeon's ability to conserve residual hearing increases, the potential to implant patients with greater levels of baseline hearing can become a reality.

[0029] The initial mechanical tissue damage caused during the insertion of the cochlear lead can be significantly reduced by minimizing the coefficient of friction between the silicone and the body tissues. The coefficient of friction can be minimized by applying a lubricant to the outer surface of the silicone cochlear lead. However, the outer surface of the silicone is smooth and hydrophobic, which prevents the uniform and permanent application of a biocompatible lubricant. This issue can be addressed by altering the chemical characteristics of the exterior of the silicone. Then, a variety of lubricants can be coated onto the lead.

[0030] In addition to the need to reduce the mechanical damage caused by the insertion of the cochlear lead, the administration of various therapeutic drugs within the cochlea can minimize the biological reactions to the surgery and presence of a foreign body. The natural inflammation and immune system responses to the insertion of the cochlear lead can be reduced by the proper application of drugs intended to counter thrombus, fibrosis, inflammation, and other negative reactions. Additionally, other drugs could be applied to prevent infection, encourage the growth or regeneration of nerve cells, or other desirable effects. Ideally, a comparatively large dose of steroid or other appropriate drug or drug combination would be administered during or shortly after implantation of the cochlear lead. Following this initial dose, a lower, long-duration dose could be administered to prevent or reduce undesirable autoimmune system responses.

[0031] In the following description, for purposes of explanation, numerous specific details are set forth in order to provide a thorough understanding of the present systems and methods. It will be apparent, however, to one skilled in the art that the present systems and methods may be practiced without these specific details. Reference in the specification to "an embodiment," "an example," or similar language means that

a particular feature, structure, or characteristic described in connection with the embodiment or example is included in at least that one embodiment, but not necessarily in other embodiments. The various instances of the phrase "in one embodiment" or similar phrases in various places in the specification are not necessarily all referring to the same embodiment.

[0032] Electrical stimulation of predetermined locations within the cochlea of the human ear through an intracochlear electrode array is described, e.g., in U.S. Pat. No. 4,400,590 (the "590 patent"), which is incorporated herein by reference. The electrode array shown in the '590 patent comprises a plurality of exposed electrode pairs spaced along and imbedded in a resilient curved base for implantation in accordance with a method of surgical implantation, e.g., as described in U.S. Pat. No. 3,751,605, which is incorporated herein by reference. The system described in the '590 patent receives audio signals, i.e., sound waves, at a signal processor (or speech processor) located outside the body of a hearing impaired patient. The speech processor converts the received audio signals into modulated radio frequency (RF) data signals that are transmitted through the patient's skin and then by a cable connection to an implanted multi-channel intracochlear electrode array. The modulated RF signals are demodulated into analog signals and are applied to selected contacts of the plurality of exposed electrode pairs in the intracochlear electrode so as to electrically stimulate predetermined locations of the auditory nerve within the cochlea.

[0033] U.S. Pat. No. 5,938,691, incorporated herein by reference, shows an improved multi-channel cochlear stimulation system employing an implanted cochlear stimulator (ICS) and an externally wearable speech processor (SP). The speech processor employs a headpiece that is placed adjacent to the ear of the patient, which receives audio signals and transmits the audio signals back to the speech processor. The speech processor receives and processes the audio signals and generates data indicative of the audio signals for transcutaneous transmission to the implantable cochlear stimulator. The implantable cochlear stimulator receives the transmission from the speech processor and applies stimulation signals to a plurality of cochlea stimulating channels, each having a pair of electrodes in an electrode array associated therewith. Each of the cochlea stimulating channels uses a capacitor to couple the electrodes of the electrode array.

[0034] Over the past several years, a consensus has generally emerged that the scala tympani, one of the three parallel ducts that make up the spiral-shaped cochlea, provides the best location for implantation of an electrode array used as part of a cochlear prosthesis. The electrode array to be implanted in the scala tympani typically consists of a thin, elongated, flexible carrier containing several longitudinally disposed and separately connected stimulating electrode contacts, conventionally numbering about 6 to 30. Such an electrode array is pushed into the scala tympani duct in the cochlea to a depth of about 20-30 mm via a cochleostomy or via a surgical opening made in the round window at the basal end of the duct.

[0035] In use, the cochlear electrode array delivers electrical current into the fluids and tissues immediately surrounding the individual electrode contacts to create transient potential gradients that, if sufficiently strong, cause the nearby auditory nerve fibers to generate action potentials. The audi-

tory nerve fibers branch from cell bodies located in the spiral ganglion, which lies in the modiolus, adjacent to the inside wall of the scala tympani.

[0036] Other patents relevant to the subject matter of cochlear stimulation leads are: U.S. Pat. Nos. 6,125,302; 6,070,105; 6,038,484; 6,144,883; and 6,119,044, which are all herein incorporated by reference. Other improved features of cochlear implant systems are taught, e.g., in U.S. Pat. Nos. 6,129,753; 5,626,629; 6,067,474; 6,157,861; 6,249,704; and 6,289,247, each of which is incorporated herein by reference.

[0037] While the electrode arrays taught in the above-referenced patents are based on the correct goal, i.e., to force the electrode carrier into a dose hugging engagement with the modiolus, they do so only by using an additional element that makes manufacture of the lead more difficult and expensive and only by applying an additional pushing force to an electrode structure after it has already been inserted into the cochlea. Such additional pushing force may cause damage to the delicate scala tympani or cause the electrode contacts to twist or to separate away from the modiolus, rather than be placed in the desired hugging relationship. Thus, while it has long been known that an enhanced performance of a cochlear electrode or lead can be achieved by proper placement of the electrode contacts dose to the modiolar wall of the cochlea, a major challenge has been obtaining an electrode/lead design that does not require excessive force to achieve this dose placement. According to one illustrative embodiment, the surface of the cochlear lead is modified to allow a lubricant to uniformly cover the cochlear lead and minimize the insertion forces and resulting trauma.

[0038] Additionally, the cochlear implant can be used as a vehicle for carrying therapeutic substances, such as steroids and antibacterial drugs, directly to disturbed tissues within the cochlea. A variety of delivery mechanisms can be used to deliver the drug or combination of drugs. A number of patents relate to manufacturing methods and drug delivery by implantable leads, including: U.S. Pat. Nos. 4,506,680 (a drug impregnated silicone plug retained within a cavity in an implantable lead); 5,092,332 (a drug impregnated polymeric layer bonded to an implantable lead); 5,103,837 (an implantable lead with a porous outer surface that contains an anti-inflammatory steroid), 5,609,029 (a cochlear implant with a drug impregnated outer coating); 5,496,360 (an implantable lead having a central cavity configured to receive various drug products); 5,824,049 (a manufacturing method for applying a drug layer covered by porous layer of biocompatible polymer to an implantable lead); 5,987,746 (an implantable lead being coated with a drug which is no more than sparingly soluble in water); 6,259,951 (an implantable cochlear lead which uses both electrode and displacement stimulation); 6,304,787 (a cochlear lead treated with a drug compound); 6,862,805 (a manufacturing method for a cochlear implant); 6,879,695 (a personal audio system with an implanted wireless receiver/audio transducer); 7,187,981 (an implantable lead with a lubrication/drug eluting coating); 7,294,345 (a generic method for biological delivery of drug compounds into a matrix); and 7,363,091 (an implantable lead containing a silicone elastomer matrix containing steroids); U.S. App. Nos.: 20070213799 (cochlear electrode arrays with drug eluting portions); 20060282123 (medical devices resistant to tissue overgrowth); 20060287689 (cochlear implants configured for drug delivery); and 20080014244 (polymer matrix for containing therapeutic drugs); European Pat. No.: EP0747069 (a manufacturing method for applying a drug

layer covered by porous layer of biocompatible polymer to an implantable lead); PCT Publication Nos. WO2008/024511 (layered matrix impregnated with therapeutic drugs) and WO2008/014234 (a cochlear implant with a drug eluting polymer material); which are all herein incorporated by reference. These patents describe a number of manufacturing techniques which can be utilized in conjunction various illustrative embodiments of cochlear implants which are described below.

[0039] According to one illustrative embodiment, the drugs may be coated on the outer surface of the implant, with the thickness and surface area of the various layers corresponding to the desired delivery drug profile and dose. In another embodiment, the drugs may also be encapsulated in a matrix which gradually releases the drugs into the intracochlear space. This matrix may be attached to cochlear lead in a variety of ways, including as a coating, a plug, or other geometry. In another illustrative embodiment, the drugs could also be delivered as a powder that is contained within a cavity of the implant. The drug type, particle size, cavity opening, covering membrane or other means could be used to control the delivery of the drug. However, in all cases, the amount of drug delivered is constrained by the need to minimize the size of the intracochlear lead. Any increase in the size of the intracochlear lead increases the potential for mechanical damage and disruption to the cochlea. Thus, a selection of the most efficacious drug or combination of drugs is important, given that only a small quantity of the drugs can be delivered via the intracochlear lead.

[0040] As mentioned above, and by various incorporated references, a variety of drugs or drug combinations could be beneficial for a patient receiving a cochlear implant. In the past, one of the primary considerations in selecting drugs for administration on electrical nerve stimulation implants (such as vagus nerve stimulators, pace makers, cochlear leads, etc.) was that the drugs should have a high solubility in aqueous solutions. The majority of the fluids within the human body contain a high percentage of water, and thus serve as an aqueous solution capable of acting as a solvent for the drugs. However, the applicants have discovered that dexamethasone base (DXMb), which has a very low solubility in aqueous solutions, was surprisingly efficacious when administered into the intracochlear space after implantation surgeries. Additionally, DXMb was surprisingly more potent than salt forms of dexamethasone. This surprising potency allows for increased therapeutic effects without increasing the volume of the drug or the size of the intracochlear lead.

[0041] FIG. 1 is a diagram showing one illustrative embodiment of a cochlear implant system (100) having a cochlear implant (300) with an electrode array that is surgically placed within the patient's auditory system. Ordinarily, sound enters the external ear, or pinna, (110) and is directed into the auditory canal (120) where the sound wave vibrates the tympanic membrane (130). The motion of the tympanic membrane is amplified and transmitted through the ossicular chain (140), which consists of three bones in the middle ear. The third bone of the ossicular chain (140), the stirrup (145), contacts the outer surface of the cochlea (150) and causes movement of the fluid within the cochlea. Cochlear hair cells respond to the fluid-borne vibration in the cochlea (150) and trigger neural electrical signals that are conducted from the cochlea to the auditory cortex by the auditory nerve (160).

[0042] As indicated above, the cochlear implant (300) is a surgically implanted electronic device that provides a sense

of sound to a person who is profoundly deaf or severely hard of hearing. In many cases, deafness is caused by the absence or destruction of the hair cells in the cochlea, i.e., sensorineural hearing loss. In the absence of properly functioning hair cells, there is no way auditory nerve impulses can be directly generated from ambient sound. Thus, conventional hearing aids, which amplify external sound waves, provide no benefit to persons suffering from complete sensorineural hearing loss.

[0043] Unlike hearing aids, the cochlear implant (300) does not amplify sound, but works by directly stimulating any functioning auditory nerve cells inside the cochlea (150) with electrical impulses representing the ambient acoustic sound. Cochlear prosthesis typically involves the implantation of electrodes into the cochlea. The cochlear implant operates by direct electrical stimulation of the auditory nerve cells, bypassing the defective cochlear hair cells that normally transduce acoustic energy into electrical energy.

[0044] External components (200) of the cochlear implant system can include a Behind-The-Ear (BTE) unit (175), which contains the sound processor and has a microphone (170), a cable (177), and a transmitter (180). The microphone (170) picks up sound from the environment and converts it into electrical impulses. The sound processor within the BTE unit (175) selectively filters and manipulates the electrical impulses and sends the processed electrical signals through the cable (177) to the transmitter (180). The transmitter (180) receives the processed electrical signals from the processor and transmits them to the implanted antenna (187) by electromagnetic transmission. In some cochlear implant systems, the transmitter (180) is held in place by magnetic interaction with the underlying antenna (187).

[0045] The components of the cochlear implant (300) include an internal processor (185), an antenna (187), and a cochlear lead (190) having an electrode array (195). The internal processor (185) and antenna (187) are secured beneath the user's skin, typically above and behind the pinna (110). The antenna (187) receives signals and power from the transmitter (180). The internal processor (185) receives these signals and performs one or more operations on the signals to generate modified signals. These modified signals are then sent through the cochlear lead (190) to the electrode array (195). The electrode array (195) is implanted within the cochlea (150) and provides electrical stimulation to the auditory nerve (160).

[0046] The cochlear implant (300) stimulates different portions of the cochlea (150) according to the frequencies detected by the microphone (170), just as a normal functioning ear would experience stimulation at different portions of the cochlea depending on the frequency of sound vibrating the liquid within the cochlea (150). This allows the brain to interpret the frequency of the sound as if the hair cells of the basilar membrane were functioning properly.

[0047] FIG. 2 is an illustrative diagram showing a more detailed view of the external components (200) of one embodiment of a cochlear implant system. External components (200) of the cochlear implant system include a BTE unit (175), which comprises a microphone (170), an ear hook (210), a sound processor (220), and a battery (230), which may be rechargeable. The microphone (170) picks up sound from the environment and converts it into electrical impulses. The sound processor (220) selectively filters and manipulates the electrical impulses and sends the processed electrical signals through a cable (177) to the transmitter (180). A

number of controls (240, 245) adjust the operation of the processor (220). These controls may include a volume switch (240) and program selection switch (245). The transmitter (180) receives the processed electrical signals from the processor (220) and transmits these electrical signals and power from the battery (230) to the cochlear implant by electromagnetic transmission.

[0048] FIG. 3 is an illustrative diagram showing one embodiment of a cochlear implant (300), including an internal processor (185), an antenna (187), and a cochlear lead (190) having an electrode array (195). The cochlear implant (300) is surgically implanted such that the electrode array (195) is internal to the cochlea, as shown in FIG. 1. The internal processor (185) and antenna (187) are secured beneath the user's skin, typically above and behind the pinna (110), with the cochlear lead (190) connecting the internal processor (185) to the electrode array (195) within the cochlea. As discussed above, the antenna (187) receives signals from the transmitter (180) and sends the signals to the internal processor (185). The internal processor (185) modifies the signals and passes them through the cochlear lead (190) to the electrode array (195). The electrode array (195) is inserted into the cochlea and provides electrical stimulation to the auditory nerve. This provides the user with sensory input that is a representation of external sound waves sensed by the microphone (170).

[0049] FIG. 4 shows a cross sectional diagram of the cochlea (150) taken along line 4-4 in FIG. 1. The walls of the hollow cochlea (150) are made of bone, with a thin, delicate lining of epithelial tissue. The primary structure of the cochlea is a hollow tube that is helically coiled, similar to a snail shell. The coiled tube is divided through most of its length by the basilar membrane (445). Two fluid-filled spaces (scalae) are formed by this dividing membrane (445). The scala vestibuli (410) lies superior to the cochlear duct. The scala tympani (420) lies inferior to the scala cochlear duct. The scala media (430) is partitioned from the scala vestibuli (410) by Reissner's membrane (440).

[0050] The cochlea (150) is filled with a watery liquid, which moves in response to the vibrations coming from the middle ear via the stirrup (145). As the fluid moves, thousands of "hair cells" (445) in a normal, functioning cochlea are set in motion and convert that motion to electrical signals that are communicated via neurotransmitters to many thousands of nerve cells (400). These primary auditory neurons (400) transform the signals into electrical impulses known as action potentials, which travel along the auditory nerve to structures in the brainstem for further processing. The terminal end of the cochlear lead (190) is inserted into the scala tympani with the electrodes (195) preferably being positioned in close proximity to the nerve (400).

[0051] As shown in FIG. 5, the tip of the cochlear lead (190) is inserted through an incision in the cochlea (150) and pushed into the scala tympani (420) so that the tip of the lead conforms to the helical shape of the scala tympani. A major problem with electrode insertion is potential damage to the delicate structures within the cochlea. To insert the cochlear lead, a passageway is made through the body tissues of the head to expose the cochlea. The tip of the electrode is inserted through an opening in the cochlea. The electrode is then pushed axially into the cochlea. The force of the tip against the inner wall of the cochlear channel bends the flexible tip. When the tip is in its final position, the electrode array is entirely contained within the cochlea and the individual elec-

trodes (195) are placed proximate the nerve cells (400). When electrical current is routed into an intracochlear electrode (195), an electric field is generated and the auditory nerve fibers (400, FIG. 4) are selectively stimulated.

[0052] Many surgeons, in an off-label practice, apply a lubricant HEALON (Pharmacia Corporation, Peapack, N.J., USA) to the electrode array to decrease the friction between the cochlear implant lead and the patient's internal tissues. However, HEALON lubricant is highly viscous and when applied at the time of surgery, there is little or no control over the conformity of the coating across the silicone surface.

[0053] According to one illustrative embodiment, a pre-coated cochlear lead can be used to ensure the desired amount of surface area is coated with a uniform and reliable lubricant. Increasing lubricity of the silicone in the cochlear implant lead will help to reduce the probability that the soft tissues of the cochlear will be torn upon electrode insertion and make the insertion of leads much easier.

[0054] FIG. 6 shows experimental results of tests performed with various materials that are used as the outer surfaces of medical devices. The vertical axis shows the range of the coefficient of friction. The horizontal axis shows various materials that were tested. For example, uncoated silicone cardiac rhythm management (CRM) leads had a coefficient of friction of approximately 1. After a hydrophilic lubricious coating was applied to the silicone, the coefficient of friction was reduced to approximately 0.1. Thus, the use of a lubricious coating may reduce friction forces by 90% or more as shown in FIG. 6 on various surfaces, including silicone as used in the cochlear lead's electrode array.

[0055] Silicone is known to be an unreactive polymer. It has a very low surface energy and is wettable by few liquids. Therefore, it is difficult to attach molecules or coatings to its surfaces. Its surfaces can be made wettable and hydrophilic by subjecting the silicone to oxygen plasma. This introduces hydroxyl groups on the exposed silicone surfaces. However, these wetting and hydrophilic properties are temporary. Silicone undergoes rapid surface inversion and reverts back to a hydrophobic and unwettable material within 24 hours.

[0056] However, within the time immediately after treatment of the silicone with oxygen plasma, these temporary hydroxyl groups may be utilized to attach coatings or to derivatize the surface. Examples of reactive molecules that could be used to modify the surface include Propyltrimethoxysilane ($C_3H_7-Si(OCH_3)_3$), Glycidoxypropyltrimethoxysilane ($CH_2(O)CHCH_2OC_3H_6-Si(OCH_3)_3$), Aminopropyltriethoxysilane ($H_2C_3H_6-Si(OC_2H_5)_3$), Aminoethylaminopropyltrimethoxysilane ($H_2NC_2H_4NHC_3H_6-Si(OCH_3)_3$), Methacryloxypropyltrimethoxysilane ($H_2C=CH(CH_3)C(O)OC_3H_6-Si(OCH_3)_3$), Mercaptopropyltrimethoxysilane ($HS(CH_2)_3Si(OMe)_3$), Chloropropyltrimethoxysilane ($ClC_3H_6-Si(OCH_3)_3$), Phenyltriethoxysilane ($C_6H_5-Si(OCH_3)_3$) and Vinyltrimethoxysilane ($H_2C=CH-Si(OCH_3)_3$). All of these compounds can react permanently with the hydroxyl groups through a covalent linkage via a silyl ether linkage. These alkoxy silanes have been added to lattices and hydrolyzed to form an interpenetrating polymer network (IPN) polymer with improved properties.

[0057] Two types of alkoxy silanes have widespread application in the coatings industries: alkyl/aryl and organofunctional. Possessing both organic and inorganic properties, these hybrid chemicals react with the polymer, forming durable covalent bonds across the interface. It has been pro-

posed that these bonds are hydrolyzable, but can reform, and therefore provide a means of stress relaxation at the organic/inorganic interface. The results are improved adhesion and durability.

[0058] FIG. 7 shows a diagram of the reaction of silanes to enhance bonding with a substrate. Initially, hydrolysis of the alkoxy groups occurs. It is after the first and second alkoxy groups are hydrolyzed that condensation to oligomers follows. The tendency toward self condensation can be controlled by using fresh solutions, alcoholic solvents, dilution, and by careful selection of pH ranges. The third methoxy group upon hydrolysis is oriented towards and hydrogen bonds with the hydroxyl groups on the silicone surface. Finally, during curing ($110^\circ C./10 min$) a covalent bond is formed with the silicone, water is liberated and the interpenetrating network is formed improving the mechanical strength and preventing surface inversion of the silicone.

[0059] The most straightforward method of silylating a surface with a silane is from an alcohol solution. A two percent silane solution can be prepared in the alcohol of choice (methanol, ethanol, and isopropanol are typical choices). The solution can be wiped, dipped, or sprayed onto the surface. After the surface dries, excess material can be gently wiped, or briefly (alcohol) rinsed off. Cure of the silane layer is for 5-10 minutes at $110^\circ C.$ or for 24 hours at ambient conditions.

[0060] The resulting additives change the surface energy of the silicone polymer (e.g., more lubricious and wettable) and makes the silicone surface much more reactive for subsequent reactions. For example, if the silicone were treated with Methacryloxypropyltrimethoxysilane, $H_2C=CH(CH_3)C(O)OC_3H_6-Si(OCH_3)_3$, it would have a free vinyl group which could subsequently be used to react with a hydrophilic vinyl containing monomer, oligomer, or polymer, forming a covalent bond by free radical reaction. This hydrophilic coating would render the silicone not only lubricious but also able to imbibe drugs for subsequent drug delivery.

[0061] As described above, one method of precisely delivering the steroid is to impregnate the chemically modified silicone of the cochlear implant lead with the steroid. The steroid leaches out of the porous silicone over time, creating a time release mechanism for delivering the steroid directly the tissue affected by the implantation of the lead.

[0062] FIG. 8 shows the drug elution of a steroid DEX salt from the polystyrene-polyisobutylene-polystyrene (SIBS) polymer coating. SIBS is an elastomeric block copolymer of polystyrene and polyisobutylene used for medical applications such as stent coatings. The vertical axis shows the total amount of DEX salt released in micrograms. The horizontal axis shows elapsed time in days. The test shows the advantageous release of large quantities of steroid immediately following the insertion of the surgical device. As the tissues heal over a period of time, the need for steroid intervention decreases. The elution profiles shown in FIG. 8 show a corresponding reduction in the rate of steroid elution over a period of days. The elution profile can be chosen to match the needs of the patient by increasing or decrease the percentage of DEX salt in the SIBS polymer.

[0063] In one alternative embodiment, the steroid is delivered in combination with lubrication. A lubricant containing a steroid substance is applied along the length in part or in whole to the cochlear lead to minimize trauma to the cochlea. The lubricant will allow the lead to be more easily inserted by reducing frictional forces that can tear soft tissues. During

insertion and post insertion of the lead, the steroid substance will diffuse into the surrounding tissues and reduce the initial trauma and subsequent inflammation that the cochlea and other tissues may experience. Minimizing inflammatory processes during and after the insertion of the cochlear lead can increase the probability of preserving residual hearing.

[0064] A class of lubricants referred to as “slippery when wet” lubricants have the characteristic of being applied, packaged, and transported as a dry powder or dry coating. Prior to insertion, the coated article is immersed or otherwise brought into contact with an aqueous solution (typically purified water or saline solution). The dry powder absorbs the solution and becomes lubricious. As the coated object is inserted into tissue, it further absorbs body fluids to enhance its low friction characteristics.

[0065] In embodiments using “slippery when wet” lubricants where the steroid is to be combined with the lubricant, the “slippery when wet” lubricant powder or dry coating is brought into contact with a steroid solution. The lubricant coating absorbs the steroid and delivers it to tissues that the coated object encounters. The steroid could also be coated directly on the silicone as part of the lubricious coating. The lubricious coating consists of one- or multiple-layer polymer coatings bound to the silicone. In the case that multiple coatings are used, the base coating may provide excellent adhesion to the silicone substrate while also containing the steroid. The top coating may provide the improved lubricity to ease the surgical implantation of the cochlear implant lead.

[0066] In these exemplary embodiments, a variety of commercially available lubricious coatings could be used. By way of example and not limitation, the following lubricants could be used: LUBRILAST from AST Products, HARMONY from SurModics, SILGLIDE from Applied Membrane Technology, HYDAK from Biocoat, F2 series from Hydromer, and others.

[0067] The lubricious coating can be applied to the lead using any of a number of techniques. For example, the lubricious coating can be applied by means of dip coating, spray coating, electro-deposition, direct printing (such as with ink-jet technology) or brush painting.

[0068] In another exemplary embodiment, the steroid could be encased in a vesicle, such as a nanoparticle or liposome vesicle, or combined with a biodegradable substance to facilitate time release. Nanoparticles and liposomes could be suspended in the lubricious coating or contained within porous coatings. In addition to the benefits described above, the polymer coating on cochlear leads may provide additional valuable characteristics such as anti-microbial, anti-thrombogenic and reduced fibrosis.

[0069] Alternative lubricants include a hydrophilic polymeric material such as plant- and animal derived natural water-soluble polymers, semi-synthetic water-soluble polymers, and synthetic water-soluble polymers. Further, the water-soluble polymers are can be stabilized (turned to be water-insoluble) by such means as crosslinking. Specific examples of the hydrophilic polymeric material include polyvinyl pyrrolidone (PVP), acrylic acid-based polymers, polyvinyl alcohols, polyethylene glycol, cellulose derivatives such as cellulose, methyl cellulose, and hydroxypropyl cellulose; sugars such as mannan, chitosan, guar gum, xanthan gum, gum arabic, glucose, and sucrose; amino acids and the derivatives thereof such as glycine, serine, and gelatin; and natural polymers such as polylactic acid, sodium alginate, and casein. In this embodiment, PVP or an acrylic acid-based

polymer can be used, in view of excellent compatibility with the underlying lead and excellent operability at the time of inserting or withdrawing the lead.

[0070] As described herein, concerns are raised by the tissue damage done when a cochlear lead is implanted. Additionally, in some patients, the presence of the implant activates the patient’s immune response resulting in a rejection of the implant. To address these issues, a steroid substance applied to surgically disrupted tissues can improve patient outcomes. The advantages of locally delivered drugs include increased local and decreased systemic drug concentration thereby lessening the potential for serious side effects. As described above, steroids, such as Dexamethasone (DEX), can help control inflammation and autoimmune responses. Dexamethasone is a potent synthetic member of the glucocorticoid class of steroid hormones. Dexamethasone demonstrates glucocorticoid (suppressing allergic, inflammatory, and autoimmune reactions) effects and serves as an antiphlogistic (anti-inflammatory) agent. Its potency is about 20-30 times that of hydrocortisone and 4-5 times that of prednisone.

[0071] When dexamethasone or its derivatives are mentioned in literature, it is invariably a reference to a dexamethasone salt. Dexamethasone salts, such as dexamethasone sodium phosphate, dexamethasone acetate, dexamethasone sulfate, dexamethasone isonicotinate, etc., are used because the water solubility of the salts forms of dexamethasone are much greater than the base form. Consequently, the salt forms were thought to be more easily delivered to living tissues and appear to be used exclusively in the prior art.

[0072] However, the inventors discovered that dexamethasone base (DXMb), which has a very low solubility in aqueous solutions, was surprisingly efficacious when administered into the intracochlear space after implantation surgeries. Additionally, DXMb was surprisingly more potent than salt forms of dexamethasone. In one study performed by the Applicants, a comparison of DXMb and DEX salt was performed in an in-vivo model over the prior of a week. The Applicants found that DXMb delivered at 1 $\mu\text{L/hr}$ at a concentration of 70 $\mu\text{L/ml}$ (limit of DXMb solubility in aq solution) was just as effective DEX salt delivered at a concentration of 100 $\mu\text{L/ml}$ at 1 $\mu\text{L/hr}$. This surprising potency allows for increased therapeutic effects without increasing the volume of the drug or the size of the intracochlear lead.

[0073] The efficacy of DXMb was also studied by the Applicants in relationship to preserving residual hearing and internal nerve structures within the cochlea. In the study performed by the Applicants, 88 ears of 44 pigmented guinea pigs of 250 to 300 grams were randomly assigned to one of four groups as follows: group 1 corresponded to the contralateral, unoperated ears from groups 2 to 4 animals (n=44). Group 2 (n=15): electrode insertion trauma (EIT); these ears underwent EIT only via a cochleostomy and then immediate closure. Group 3 (n=15): EIT+artificial perilymph (EIT+AP) treated ears received EIT and immediately after trauma, insertion of a microcatheter into the cochleostomy site with AP perfused into the scale tympani (ST) for a period of 8 days. Group 4 (n=14): EIT dexamethasone base (EIT=DXMb) treated animals underwent EIT followed immediately by insertion of a microcatheter into the cochleostomy with ST perfusion of DXMb (70 g/mL) in AP for a period of 8 days. Hearing measurements were performed before surgery, as well as on post-EIT days 0, 3, 7, 14, and 30. Tone bursts of 0.5, 1, 4, and 16 kHz were delivered to the ear at a rate of 29 Hz. The intensity of the stimulation was decreased by 10 dB

sound pressure level (SPL) decrements until no auditory brainstem response was identified.

[0074] FIG. 9 shows charts auditory functions of the various test groups as a function of time. Each of the charts show box plots of mean auditory brainstem response threshold values by time for a set of low (0.5 kHz) frequency pure tone stimuli. A line passes through mean value of each the temporal measurement. The ends of the boxes are the 25th and 75th quartiles. The horizontal line across the middle of the boxes identifies the median threshold values. The whiskers at the ends of the boxes extend to the outermost data points. (A) Represents values for the control ears (group 1, n=44), (B) for group 2 (EIT, n=15), (C) for group 3 (EIT+AP, n=15), and (D) for group 4 (EIT+DXMb, n=14).

[0075] Chart A in FIG. 9 shows that there is no change the hearing capability in the control ears which have not been disturbed by surgery. Chart B shows that there is significant hearing loss (the measurements trend higher, showing that an increase tone volume is required to detect an auditory brainstem response) for ears where there was surgery performed but no treatment was provided. Similarly, Chart C shows that there was a significant hearing loss in ears where a placebo (artificial perilymph) was administered. Chart D shows test results for ears where DXMb was administered. In Chart D, there was a sharp increase in hearing loss immediately following the surgery, but this hearing loss was reversed by the administration of the DXMb. Over the long term, the administration of DXMb maintained the pre-operative hearing levels.

[0076] FIG. 10 shows that DXMb treatment similarly conserves auditory function thresholds at 16 kHz after electrode insertion trauma. Chart A shows that there is no significant change the hearing capability in the control ears which have not been disturbed by surgery. Chart B shows that there is dramatic hearing loss for ears where there was surgery performed but no treatment was provided. Chart C shows that there was a less dramatic but still significant hearing loss in ears where a placebo was administered, Chart D shows test results for ears where DXMb was administered. In Chart D, there was a sharp increase in hearing loss immediately following the surgery, but this hearing loss was reversed, and continued to decline as DXMb was administered. Consequently, it can be concluded that DXMb treatment can conserve auditory function thresholds over a range of frequencies after electrode insertion trauma.

[0077] FIG. 11 shows Organ of Corti photomicrographs from an area of the lower middle turn of four representative cochleae thirty days after electrode insertion trauma. The control specimen (photomicrograph A) is the contralateral unoperated cochlea which shows the undamaged structure of hair cells (arrow, "HCs"). The organization of hair cells is in three distinct rows. Microphotograph B shows an area of damaged hair cells (arrow, "Damaged HCs") from the group which received no treatment following electrode insertion trauma. Microphotograph C shows an area of damaged hair cells (arrow, "Damaged HCs") from the group which received a placebo treatment. However, microphotograph C shows that there are fewer missing hair cells than shown in B. A possible explanation for the better preservation of hair cells receiving the placebo treatment (the cochlea was flushed with artificial perilymph rather than DXMb) was that the flushing action reduced the autoimmune actors in the intracochlear space. Microphotograph D is a photograph of hair cells from a specimen that received DXMb treatment following electrode

insertion trauma. The hair cells and hair cell structure of microphotograph D are substantially similar to that of the control group, showing that DXMb treatment is effective in reducing damage to intracochlear structures following electrode insertion trauma.

[0078] As mentioned above, optimal delivery of a steroid as a means of minimizing negative surgical side effects varies by situation, but typically delivery directly to the disturbed tissues is desired. For example, the base or salt form of Dexamethasone can be combined with either or both of a surface lubricant or the underlying silicone. The sodium salt form of dexamethasone is highly soluble in aqueous preparations which allows for the application of very high dose levels of this synthetic corticosteroid if required. In contrast, the base variant of dexamethasone (i.e., DXMb) is highly soluble in organic solvents but has limited solubility in aqueous preparations. This difference in solubility between the salt and base forms of dexamethasone can be leveraged to provide a time varying release profile of steroid into the intracochlear space. For example, a high dosage of steroid is often found to be beneficial during or immediately following the surgery and implantation process. This high dosage of steroid or other anti-inflammatory drug can mitigate swelling, nerve damage, and aid in the post operative recovery of the patient. For a period of time after the surgery, a lower level and sustained release of steroid or other medication can be desirable to prevent immune system rejection of the cochlear implant, ossification, tissue build up within the cochlea, and progressive nerve damage.

[0079] The combination of DEX salt and DXMb can provide a time varying release of steroids. According to one illustrative embodiment, various layers of drugs could be applied to achieve the desired release profile and combination of drugs. For example, an outer layer could be composed of DEX salt and an inner layer could be composed of DXMb. The outer layer of DEX salt would be rapidly released during the implantation, while the inner layer of DEX salt would be more slowly released for long term treatment. Other drugs could be used in combination with DEX salts or DXMb to supply a broader spectrum of benefits. By way of example and not limitation, a heparin layer could be added as a thrombin inhibitor. The layering sequence and compositions could also be used to control the release rate of various drugs. For example, a heparin under layer could be used to increase the release rate of an overlying DEX salts or DXMb by about a factor of 10. The various layers could be applied using a variety of techniques. By way of example and not limitation, the layers could be applied by painting, spraying, printing (similar to ink jet technology using large or very small (picoliter) droplets), and/or dipping the lead until the desired dose is applied.

[0080] In one illustrative embodiment, the DEX salt or DXMb could be dissolved in a carrier fluid and applied to cochlear lead surface. The carrier would then evaporate or otherwise be removed, leaving the DEX salt or DXMb layer or layers in place on the cochlear lead. A number of solvents could be used. For DEX salt coatings, various aqueous solutions could be used. For DXMb coatings, organic solvents could be used. By way of example and not limitation, these organic solvents may include methanol, ethanol, isopropanol, acetone, chloroform, and others. A variety of factors could influence the choice of carrier solutions, including: the solubility of DEX salt or DXMb in the chosen solution, the evaporation rate of the carrier, the ease of applying and han-

ding the solution, the toxicity of any remaining carrier, the compatibility of the carrier with the underlying substrates, and other factors.

[0081] FIG. 12 is a cross-sectional diagram of a cochlear lead (1200) that is coated with multiple drug eluting layers (1205, 1210). According to one illustrative embodiment, a first layer (1210) containing DXMb is deposited on the outer surface of the cochlear lead (1200). A second layer (1210) containing a DEX salt is deposited over the first layer (1210). As discussed above, the DEX salt highly soluble in water or solutions that contain a high percentage of water. The intracochlear fluid is primarily water. Consequently, the DEX salt is quickly dissolved by the intracochlear fluid and rapidly attains a relatively high concentration of DEX salt within the fluid. By configuring the cochlear implant to make available a given amount of DEX salt from the second layer (1210) during and immediately after implantation, the desired burst of steroid can be administered. After the initial release of DEX salt, the DXMb contained within the second layer (1205) can provide lower levels of steroid within the cochlea for a sustained period. The saturation concentration of DXMb within the cochlear fluid is much lower than that of DEX salt, leading to a slower release/dissolution of the DXMb into the cochlear fluid. Additionally, as described above, it has been found that DXMb can be more potent on a per mass basis than a DEX salt. This allows a larger therapeutic dose of DXMb to be delivered within the size constraints imposed by the cochlea and electrode geometries. Although no concrete explanation for the higher potency is provided, this could possibly be due to longer clearance times of DXMb. A clearance time is measurement of the time during which a drug remains within a portion of the body before it is transported or otherwise removed from the body. The lower solubility of the DXMb may lead to slower transport of the DXMb out of the intracochlear region.

[0082] FIG. 13 shows a chart illustrating hypothetical drug dose and release kinetics associated with a DEX salt/DXMB combination, such as the geometry illustrated in FIG. 12. The horizontal axis of the chart represents the passage of time after administration of the DEX salt/DXMB combination. The vertical axis represents the intracochlear drug concentrations. A dashed line (1300) illustrates a hypothetical release profile for DEX salt. As shown by the dashed line (1300), the DEX salt is rapidly dissolved by the intracochlear fluid and, due to the high solubility of the DEX salt in the intracochlear fluid, a high concentration of DEX salt rapidly accumulates in the cochlea. This high concentration of DEX salt mitigates the immediate damage caused by the electrode insertion. The concentration of the DEX salt rapidly declines as the DEX salt is consumed and/or transported out of the cochlea. The DXMB concentrations are illustrated by a dot-dash line (1305). The DXMB concentrations increase much more slowly and are sustained within the intracochlear space for a longer period of time.

[0083] The DEX salt/DXMB combination could be combined with the cochlear implant in a number of alternative methods. For example, a cochlear implant could be coated with a hydrophilic layer. The hydrophilic layer could be made up of a number of materials that would absorb or retain an aqueous solution, such as a "slippery when wet" lubricant or a hydrogel such as HYDROMER polyvinyl pyrrolidone. A DEX salt or a combination of DEX salt and DXMB could be dissolved in the solution. The aqueous solution could then be used to load the hydrophilic layer with DEX salt or DXMB. In

one embodiment, the all or a portion of the cochlear implant could packaged and shipped in the solution. In other embodiments, the cochlear implant could be soaked in the DEX solution prior to use. In one illustrative embodiment, the solution could include a combination of aqueous and organic solvents to provide the desired delivery of DEX salt and DXMB.

[0084] FIG. 14A shows an alternative embodiment of a cochlear lead (1400) where a DXMB layer (1405) is applied to the cochlear lead (1400), followed by a lubricant layer (1410). Prior to the insertion of the cochlear lead (1400) into the body tissues, the lead is submerged in an aqueous solution containing DEX salt (1415). The aqueous solution (1415) is absorbed by the lubricant layer (1410). This hydrates the lubricant and reduces the coefficient of friction between the cochlear lead (1400) and the surrounding tissues. Additionally, a portion of the DEX salt is eluted out of the lubricant layer (1410) as the cochlear lead passes through the tissues, thereby directly depositing the steroid on the disturbed tissues. Further, because the DXMB layer (1405) has only a low solubility in aqueous solutions, it will not dissolve or lose its structural integrity during the hydration and insertion process.

[0085] Another advantage of DXMB relates to its high solubility in organic solvents. Organic solvents are used in a variety of processes, including the preparation of polymers. By dissolving DXMB in an organic solvent, DXMB can be easily incorporated into a variety of biocompatible polymers. The DXMB can then be gradually eluted from the polymer to produce the desired drug release kinetics.

[0086] FIG. 14 B shows an illustrative embodiment of a cochlear lead (1400) with a polymer coating (1420). According to one illustrative embodiment, the polymer coating (1420) includes mixed active agents which gradually are eluted polymer coating. For example, the mixed active agents may include a combination of DXMB and DEX salts. As discussed above, the ratio of DXMB and DEX salts may be adjusted to achieve the desired release profile and biological benefit. The polymer coating (1420) may be applied using a variety of methods. By way of example and not limitation, the polymer coating (1420) may be applied by dip coating, brush coating, spray coating or other methods.

[0087] FIG. 14 C shows an illustrative embodiment of a cochlear lead (1400) with an active layer (1430) which is covered by a polymer coating (1435). According to one illustrative embodiment, the active layer (1430) may include mixed active agents such as a combination of DXMB and DEX salts. The polymer coating (1435) may serve as a protecting layer which prevents the active layer (1430) from damage. Additionally, the polymer coating (1435) may serve as a membrane which moderates the release rate of drugs which are eluted from the active layer (1430).

[0088] According to one illustrative embodiment, the polymer coating (1435) may be hydrophobic or hydrophilic. Advantages of a hydrophobic coating may include lower permeability to water solutions, longer term dimensional stability, lower elution rates of drugs from the underlying active layer. Advantages of a hydrophilic coating may include higher elution rates of drugs from the underlying active layer, greater lubricity, the ability to absorb and carry water soluble solutions. According to one illustrative embodiment, the polymer coating (1435) has a higher lubricity than the underlying silicone surface of the cochlear lead (1400).

[0089] FIG. 15 shows a cross-sectional diagram of a cochlear lead (1500) with an electrode (1505) and a cavity

(1520) which runs along the length of the intracochlear lead (1500). The cavity (1520) could have a variety of geometries as best suits the situation. For example, the cross-sectional shape of the cavity (1520) could be altered to best retain and dispense the drug or drug combination contained within the cavity (1520). According to one illustrative embodiment, the cavity (1520) is filled with a matrix which contains DXMb (1510). As described, above DXMb can be incorporated into a number of biocompatible polymers. This drug loaded polymer can be shaped to fill a variety of cavity geometries. According to one embodiment, the drug loaded polymer may adhere to the cavity wall or be applied as a coating to the cochlear lead surface.

[0090] In an alternative embodiment, powdered drugs or drug combinations may be used to fill the cavity (1520). A selectively permeable membrane (1515) may be used to cover the opening of the cavity (1520) and retain the powder. When the cochlear implant is inserted into tissue or the intracochlear space, body fluids pass through the membrane and dissolve the drug particles, which then pass through the membrane and into the surrounding tissues. According to one exemplary embodiment, DXMb powder (1510) is used to fill the tissue, and a membrane (1515) having a pore size of no greater than 10 microns is used to retain the DXMb powder (1510). According to one illustrative embodiment, the pore size is less than 6 microns. In another illustrative embodiment, the pore size is less than 0.2 microns. The membrane (1515) pore size is configured to prevent the passage of bacteria across the membrane but allows water and dissolved DXMb cross the membrane. Smaller pore sizes may exclude a greater number of bacteria. In other embodiments, the membrane may have pore sizes that range from nanofeatures to very large macroscopic holes. In one illustrative embodiment, the membrane may be eliminated entirely and the solution may directly enter the cavity.

[0091] Alternatively or additionally, the outer covering of the cochlear implant could be molded with features which facilitate the retention of DEX and any carrier medium. By way of example and not limitation the outer covering of the insulating silicone could be molded with grooves, wells, indentations, or cavities. According to one exemplary embodiment, a porous coating made from a hydrophilic polymer covers the implant lead and is configured to be impregnated with various drug eluting substances. In one illustrative embodiment, a suspension of silicone and DEX could be inserted into these features and transported into the cochlea, where the DEX could be released into the intra cochlear space. In an alternative embodiment, these features can be filled with drugs in a powdered form. A thin layer or layer of variable thickness of silicone or other coating polymer could be applied to seal or partially seal the hole to give rise to the desired release kinetics. A number of factors could influence the release kinetics. By way of example and not limitation, these factors could include the permeability of the covering membrane to intracochlear or body fluids, the permeability of the covering membrane to the drug or combination of drug in the interior, the surface area of the covering membrane, the quantity of drug powder, the solubility of the drug powder, the range of particulate sizes in the powder, and other factors. As discussed above, DEX salt, DXMb, and other therapeutic drugs could be combined to deliver the desired therapeutic effect.

[0092] The various therapeutic drugs can be combined with polymers in various geometries to assist in the desired deliv-

ery. For example, in some circumstances, it may be desirable to control the elution rate of various drugs by overcoating the drug layers with a polymeric layer. According to one embodiment, the overcoating polymeric layer may be deposited by vapor or plasma deposition of the polymer agent to create a porous membrane. This allows the deposition of the overcoat without the use of solvents, catalysts, heat or other chemicals or techniques which would cause damage to the agent, drug, or material. The polymeric overcoat layer can allow for less retention of unused drug within in the implanted device. Additionally, the polymeric overcoat can prevent undesirable fragmentation of biodegradable interior substances.

[0093] In conjunction with the methods mentioned above, a variety of surface treatments can be used to render the surface more amenable to the subsequent processes. By way of example and not limitation, these methods can include cleaning physical modifications such as etching, drilling, cutting, or abrasion; and chemical modifications such as solvent treatment, the application of primer coatings, the application of surfactants, plasma treatment, ion bombardment, and covalent bonding.

[0094] By way of example and not limitation, examples of biodegradable polymers which can be used as a matrix to contain and dispense various therapeutic compounds may be selected from suitable members of the following, among many others: (a) polyester homopolymers and copolymers such as polyglycolide, poly-L-lactide, poly-D-lactide, poly-D,L-lactide, poly(beta-hydroxybutyrate), poly-D-gluconate, poly-L-gluconate, poly-D,L-gluconate, poly(epsilon-caprolactone), poly(delta-valerolactone), poly(p-dioxanone), poly(trimethylene carbonate), poly(lactide-co-glycolide) (PLGA), poly(lactide-co-delta-valerolactone), poly(lactide-co-epsilon-caprolactone), poly(lactide-co-beta-malic acid), poly(lactide-co-trimethylene carbonate), poly(glycolide-co-trimethylene carbonate), poly(beta-hydroxybutyrate-co-beta-hydroxyvalerate), poly[1,3-bis(p-carboxyphenoxy)propane-co-sebacic acid], and poly(sebacic acid-co-fumaric acid), among others, (b) poly(ortho esters) such as those synthesized by copolymerization of various diketene acetals and diols, among others, (c) polyanhydrides such as poly(adipic anhydride), poly(suberic anhydride), poly(sebacic anhydride), poly(dodecanedioic anhydride), poly(maleic anhydride), poly[1,3-bis(p-carboxyphenoxy)methane anhydride], and poly[alpha,omega-bis(p-carboxyphenoxy)alkane anhydrides] such as poly[1,3-bis(p-carboxyphenoxy)propane anhydride] and poly[1,3-bis(p-carboxyphenoxy)hexane anhydride], among others; and (d) amino-acid-based polymers including tyrosine-based polyarylates (e.g., copolymers of a diphenol and a diacid linked by ester bonds, with diphenols selected, for instance, from ethyl, butyl, hexyl, octyl and benzyl esters of desaminotyrosyl-tyrosine and diacids selected, for instance, from succinic, glutaric, adipic, suberic and sebacic acid), tyrosine-based polycarbonates (e.g., copolymers formed by the condensation polymerization of phosgene and a diphenol selected, for instance, from ethyl, butyl, hexyl, octyl and benzyl esters of desaminotyrosyl-tyrosine), and tyrosine-, leucine- and lysine-based polyesteramides; specific examples of tyrosine-based polymers include includes polymers that are comprised of a combination of desaminotyrosyl tyrosine hexyl ester, desaminotyrosyl tyrosine, and various di-acids, for example, succinic acid and adipic acid, among others.

[0095] According to one embodiment, DXMb may also be delivered in bio-release polymer matrix. The bio-release

polymer matrix containing DXMb may be used and shaped in a variety of ways. By way of example and not limitation, a cochlear implant electrode array coated with a DXMb impregnated polymer that can bio-release this drug at a pre-determined rate that is determined at the time of fabrication.

[0096] According to one exemplary embodiment, the various drug components can be incorporated into a polymeric matrix, which is then applied to the cochlear lead. The polymeric matrix layer may be fabricated in a variety of ways. By way of example and not limitation, a mixture can be formed from 0.2 milligrams of dexamethasone sodium phosphate with 0.5 cubic centimeters of silicone medical adhesive. The mixture is molded to the desired shape and allowed to cure. After curing the polymeric matrix layer is attached to the outer substrate with silicone medical adhesive such as SILASTIC by Dow Corning. The thickness of the drug impregnated polymeric coating can be varied to deliver the optimal amount of drug dosage over the lifetime of the device. The coating may also cover varying portions of the implant. For example, the coating may cover the entire implant lead or may be applied to only a portion of the lead so that the electrodes are not covered.

[0097] Polymer matrix which as been impregnated with DXMb or another drug can be shaped into a variety of geometries and incorporated into a cavity within the lead. This cavity may be covered by a porous elution path. The porous elution path may be created by placing a layer of cindered platinum or titanium foam over the cavity opening. According to one embodiment, the particles of DEX salts or DXMb, combinations there of, can be mixed with silicone rubber medical adhesive. The silicon rubber medical adhesive is permeable by water vapor, which dissolves the DEX salts or DXMb. The dissolved DEX salts or DXMb then elute from the matrix into the cochlear space. In one illustrative embodiment, particles of dexamethasone sodium phosphate, which has a relatively fast elution rate, and particles of DXMb, which has a much slower elution rate, can be use in combination to achieve the desired release profile. As mentioned above, a number of other factors, such as particle size, surface area, matrix, etc. can be used to further adjust the drug release over time.

[0098] In an alternative embodiment, a silicone elastomer matrix is used rather than silicon medical adhesive. The silicon elastomer may provide a number of manufacturing advantages including longer pot life and a shorter curing time. According to one illustrative method, two silicon elastomer precursor compounds are combined with a third compound which carries the drug particles. The third compound may be silicone fluid and the drug particles may be made up of DXMb or similar compound. The three components are mixed and placed in a mold. The temperature of the matrix and mold can be controlled to assist in curing the matrix. After the molding process is complete, the silicon shape can be placed in or on the cochlear lead as desired.

[0099] All of the above methods of dispensing therapeutic compounds can be combined with various lubrication techniques. Additionally, the drug layer may have lubricant properties or a lubrication layer which contains drug compounds may be included.

[0100] FIGS. 16 and 17 show an illustrative embodiment of a cochlear lead (1600) with various electrodes (1610) along one side and a lumen (1605) passing longitudinally through the cochlear lead. The lumen (1605) may access the surrounding tissues through one or more apertures (1615). According

to one embodiment, the lumen (1605) may serve as a drug reservoir. For example, the lumen (1605) could contain a powdered DEX salt (1620) near the aperture (1615) and powdered DXMb (1625) in the remainder of the lumen (1605). The aperture (1615) could be covered with a membrane (1630) to retain the drug powders (1620, 1625) and control the passage of solutes and particles through the aperture (1615). Additionally or alternatively, the lumen (1605) could be filled with a suspension of silicone and DEX salt/DX Mb. The lumen could be filled with the drug or drug eluting compound during manufacturing or just prior to use.

[0101] FIGS. 18A and 18B are a top view and cross-sectional diagram, respectively, of illustrative dispensing mechanism for pharmaceutical agents. According to one illustrative embodiment, a solid tablet (1820) of steroid is contained within a housing (1805). An aperture (1810) on one side of the housing (1805) is covered with a membrane (1815). When implanted in conjunction with a medical device, the solid tablet (1820) of steroid is gradually dissolved and elutes through the membrane into the body.

[0102] According to one illustrative embodiment, the tablet (1820) is has a cylindrical shape with dimensions of approximately 1.5 mm in diameter and 1.5 mm in height. The tablet (1820) may contain approximately 0.5 milligrams of steroid and elute approximately 0.6 to 0.3 micrograms per day into the surrounding tissues over the course of 30 months. The tablet may be comprised of a number of steroid or other medications. By way of example and not limitation, the tablet may comprise dexamethasone base or fluocinolone acetonide.

[0103] The housing (1805) may be made of a variety of materials that are biocompatible and have low permeability. For example, the housing (1805) may be a silicone elastomer. The membrane (1815) may be made from a variety of biocompatible materials that have higher permeability, such as polyvinyl alcohol (PVA).

[0104] FIGS. 19 and 20 are a cross-sectional diagram and top view of an illustrative cochlear lead that incorporates a tablet similar to that described in FIG. 18. In this illustrative embodiment, the silicone body of the cochlear lead (1900) forms the housing for the tablet (1820). An aperture (1905) is formed within the cochlear lead (1900). The tablet (1820) is placed within a cavity underlying the aperture (1905) and the aperture is covered by a membrane (1815). According to one embodiment, the membrane (1815) maintains its structural integrity throughout the lifetime of the cochlear lead. This prevents undissolved portions of the tablet from exiting through the aperture.

[0105] In some embodiment, the tablet may be significantly smaller than 1.5 mm. Additionally, multiple tablets may be incorporated into the cochlear lead to achieve the desired drug combination and release profile. In some circumstances, an active drug releasing tablet may not be inserted into a cavity (1920). Instead, the cavity may be left empty or a placebo could be inserted into the cavity (1920). Additionally or alternatively, other compounds, such as DEX salt tablet (1915) or other therapies can be inserted into one or more of the cavities. For example, therapies which support regrowth of hair cells or containing stem cells could be contained within one or more of the cavities. This modularity allows the cochlear lead to be customized for the particular needs of the patient and leaves flexibility to incorporate future advances in beneficial therapies. The apertures and membranes covering the apertures may be modified to permit the most effectual release

profiles of the therapies contained within the corresponding cavities. For example, the membrane covering a therapy that includes larger molecules may be thinner or more porous to allow the molecules to diffuse through the membrane.

[0106] FIG. 21 shows a cochlear lead (2100) that has a longitudinal cavity (2110) which is configured to receive a drug releasing capsule (2130). The drug releasing capsule (2130) may be held in place within the longitudinal cavity in a number of ways. By way of example and not limitation, the capsule (2130) may be glued in place with silicone medical adhesive or another biocompatible adhesive. The adhesion between the drug release capsule (2130) and the supporting structure may be optimized by using a variety of surface treatments. Additionally or alternatively, the cavity (2110) may incorporate a number of features, such as overhanging walls, which mechanically secure the capsule (2130) in place.

[0107] The drug releasing capsule (2130) may be in a variety of shapes and sizes that are compatible with connection to the cochlear lead (2100). According to one illustrative embodiment, the drug release capsule (2130) may have a rod shaped housing that contains drugs or drug generating materials. The drug elutes through a membrane (2140) into the surrounding tissues. As discussed above, the membrane pores may be sized to prevent the passage of bacteria or other contaminants. For example, pore sizes of 0.2 microns or less substantially prevent bacterial ingress and egress from the drug releasing capsule.

[0108] The drug releasing capsule (2130) may also have number of alternative embodiments. By way of example and not limitation, the capsule (2130) may comprise a matrix which encapsulates the drug. The drug then gradually elutes from the matrix to deliver the desired drug profile. In an alternative embodiment, a dry powdered drug may be completely encapsulated by a flexible membranous material. By way of example and not limitation, the flexible membranous material may be porous PolyTetraFluoroEthylene (PTFE), a silicone membrane, Fluorinated Ethylene Propylene (FEP), or cellulose acetate. Additionally or alternatively, a fluid or suspension of drug may be encapsulated by the flexible membranous material. Other embodiments of the capsule (2130) may include a micro-osmotic pump which dispenses a controlled amount of a liquid drug. In some embodiments, the liquid drug may be dissolved in a carrier fluid. In other embodiments, the liquid drug may comprise drug particles in suspension.

[0109] The drug release profile can be controlled using a number of factors. These factors may include the dimensions of the capsule (such as length, diameter, cross-sectional geometry, etc.); the placement of the membrane on the capsule; and membrane characteristics (such as thickness, surface area, permeability, pore size, etc.). The drug placed within the capsule can also influence the release profile. As mentioned above, a combination of DXMB and DEX salt powders could be used. The ratio of DXMB to DEX salt powders could be designed to achieve the desired drug release profile. For example, increasing the amount of DEX salt powder would increase the initial burst of drug upon implantation. Increasing the amount of DXMB powder, which has a much lower solubility in aqueous solutions, could extend the length of the treatment. Additionally, the particle sizes of the drug powders could be altered. For example, large particle sizes may decrease the total surface area of the drug powder and slow the release of drug, while smaller particle sizes increase the total surface area and may increase the release rate of the

drug. Microspheres are one example of particles which could be used to influence a drug release profile.

[0110] The placement of the particles within the capsule (2130) could also influence the drug release. According to one illustrative embodiment, the membrane (2140) may be positioned such that a first portion of the capsule (2130) has more direct access to the membrane (2140) than second portion of the capsule (2130). Consequently, drug agents placed in the first portion of the capsule could be expected to elute through the membrane (2140) in greater proportion than drug agents placed in the second portion of the capsule.

[0111] Additionally or alternatively, the capsule (2130) may incorporate genetically engineered cells which absorb nutrients from the tissue surrounding the implantation site and produce a therapeutic agent. According to one embodiment, the genetically engineered cells are contained within a polymer membrane capsule which is inserted into the implantation site. The nutrients from the surrounding tissues diffuse through the polymer membrane to sustain the genetically engineered cells. The genetically engineered cells then manufacture the therapeutic drug according to the genetic instructions which have been inserted into their genome. The therapeutic agent diffuses through the membrane and into the surrounding tissues. This approach has the potential advantages of a long lifetime, smaller capsule size, the ability to continuously deliver freshly synthesized therapeutic agents, and the ability to manufacture in situ a variety of therapeutic agents that are unstable or otherwise difficult to effectively administer.

[0112] The use of a modular tablet or capsule as a means of drug delivery has a number of benefits and advantages. A first advantage may be that the tablet or capsule design can be relatively independent of the electrode design. For example, the capsule may be constructed of different materials and by a different process than the electrode. When compared to coating methods used to deliver therapeutic agents, the capsule or tablet may have a significantly smaller effect on the lubricity of the electrode. A second advantage is that the tablet or capsule can be tested independent of the full device. This could decrease development times and lower manufacturing costs. A third advantage may be that the modularity of the system allows for the cochlear lead to be customized to meet the individual medical needs of the patient. A wide variety of therapeutic drugs or other pharmaceutical agents could be inserted into the tablet or capsule. If no therapeutic agent is desired, the preformed cavity could simply be filled with a silicone blank. Fourth, the modularity of the system allows for new innovations to be incorporated into a drug delivery tablet or capsule and inserted into the cochlear lead without the need to redesign and retest the entire system. The modularity also allows an experienced third party vendor to make the tablet or capsule, which could result in significant cost reduction. Fifth, the incorporation of a modular capsule can simplify the process of assembling the cochlear lead. When compared to the coating process, which requires expensive coating equipment, the insertion of a tablet or capsule into a preformed cavity is significantly less complex and time consuming.

[0113] The preceding description has been presented only to illustrate and describe embodiments and examples of the principles described. This description is not intended to be exhaustive or to limit these principles to any precise form disclosed. Many modifications and variations are possible in light of the above teaching.

What is claimed is:

1. A system for delivering a therapeutic agent to biological tissue comprising:

a surgically implantable lead configured to be inserted into the biological tissue, the surgically implantable lead comprising a preformed cavity; and

a modular capsule configured to be retained within the preformed cavity, the modular capsule comprising a first therapeutic agent and a second therapeutic agent, wherein the first therapeutic agent is configured to rapidly elute into the biological tissue and the second therapeutic agent is configured to more slowly elute into the biological tissue.

2. The system of claim **1**, wherein the first therapeutic agent has a higher solubility in aqueous solutions than the second therapeutic agent.

3. The system of claim **1**, wherein the first therapeutic agent comprises dexamethosone (DEX) salt and the second therapeutic agent comprises dexamethosone base (DXMb).

4. The system of claim **3**, wherein the DEX salt elutes into a surrounding aqueous solution at higher concentrations than the DXMb.

5. The system of claim **1**, further comprising a permeable membrane interposed between the biological tissue and therapeutic agents, wherein the first therapeutic agent in a first portion of the capsule has greater access to the membrane and elutes through the membrane in greater proportion than the second therapeutic agent placed in a second portion of the capsule with lesser access to the membrane.

6. The system of claim **5**, wherein the permeable membrane comprises least one of porous polytetrafluoroethylene, a silicone membrane, fluorinated ethylene propylene, or cellulose acetate.

7. The system of claim **1**, wherein at least one of the first therapeutic agent and the second therapeutic agent comprise microspheres.

8. The system of claim **1**, wherein the first therapeutic agent comprises powered dexamethosone (DEX) salt having a first particle size and the second therapeutic agent comprises dexamethosone base (DXMb) having a second different particle size.

9. The system of claim **8**, wherein the modular capsule further comprises a permeable membrane encapsulating the powered DEX salt and DXMb.

10. The system of claim **1**, wherein the modular capsule comprises a polymer matrix and mixed DXMb and DEX salt particulates.

11. The system of claim **1**, wherein the preformed cavity is covered by porous metal layer comprising a number of porous elution paths.

12. A system for delivering a therapeutic agent to biological tissue comprising:

a surgically implantable lead configured to be inserted into the biological tissue, the surgically implantable lead comprising a preformed cavity; and

a modular capsule configured to be retained within the preformed cavity, the modular capsule comprising a drug release profile when inserted in biological tissue, the drug release profile comprising a high initial concentration of a first therapeutic agent and a long term lower concentration of a second therapeutic agent.

13. A modular capsule for delivering a therapeutic agent to biological tissue, the modular capsule comprising:

a membrane;

a first portion comprising a first therapeutic agent; and

a second portion comprising a second therapeutic agent;

wherein the first portion has more direct access to the membrane than the second capsule such that the first therapeutic agent elutes through the membrane in greater proportion than the second therapeutic agent.

14. The capsule of claim **13**, wherein the first therapeutic agent comprises dexamethosone (DEX) salt and the second therapeutic agent comprises dexamethosone base (DXMb).

15. The capsule of claim **13**, wherein elution of the first therapeutic agent comprises a first particle size and the second therapeutic agent comprises a second particle size.

16. The capsule of claim **13**, wherein the modular capsule comprises a solid tablet comprising DXMb and DEX salt.

17. The capsule of claim **13**, wherein the capsule releases approximately 0.3 to 0.6 micrograms per day of DXMb into cochlear tissues.

18. The capsule of claim **13**, wherein the membrane comprises polyvinyl alcohol (PVA) and walls of the capsule comprise silicone.

* * * * *