

Dec. 18, 1923.

J. B. GLOWACKI

1,477,643

FUSE PLUG

Filed July 21, 1919

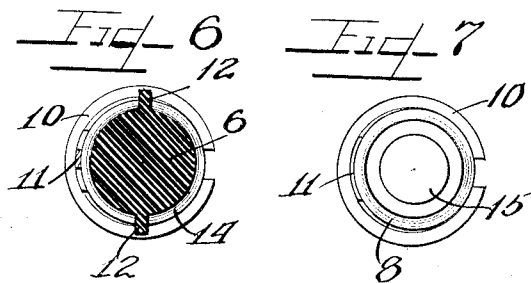
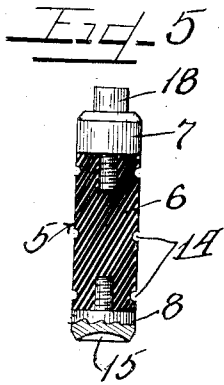
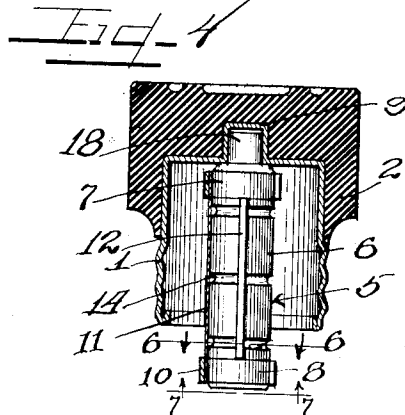
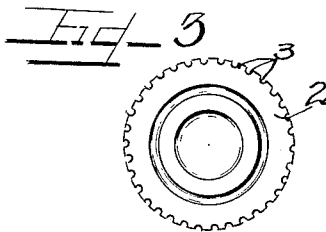
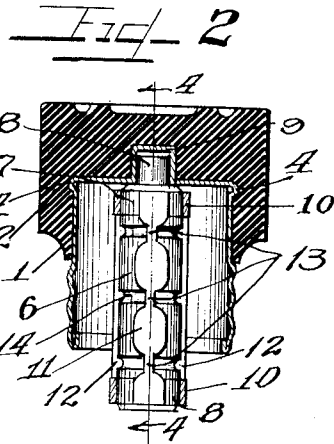
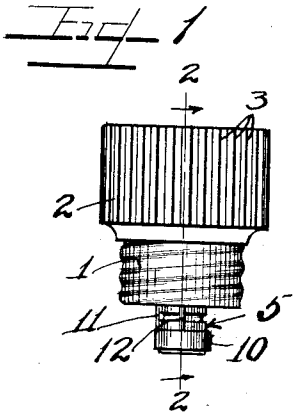

WITNESSES

*Wm. Angell*  
*Charles H. Hill, Jr.*

INVENTOR

*John B. Glowacki*

*Charles H. Hill, Jr.*  
by ATTY

# UNITED STATES PATENT OFFICE.

JOHN B. GLOWACKI, OF CHICAGO, ILLINOIS.

## FUSE PLUG.

Application filed July 21, 1919. Serial No. 312,341.

*To all whom it may concern:*

Be it known that I, JOHN B. GLOWACKI, a subject of the Republic of Poland, having declared my intention to become a citizen of the United States, and a resident of the city of Chicago, in the county of Cook and State of Illinois, have invented certain new and useful Improvements in a Fuse Plug; and I do hereby declare that the following is a full, clear, and exact description of the same, reference being had to the accompanying drawings, and to the numerals of reference marked thereon, which form a part of this specification.

This invention relates to screw contact fuse plugs, more particularly plugs adapted to screw into a fuse cutout box.

Hitherto screw contact fuse plugs have been constructed so that it is difficult to insert a new fuse link after the fuse has blown and further in many cases insufficient ventilation has been provided around the fuse link to ensure its action at proper times and prevent fusion thereof as the result of long continued passage of current of safe amperage.

One of the objects, therefore, of this invention is to provide a simple, economical form of construction of screw contact fuse plugs in which the fuse is firmly held and yet readily replaceable when necessary.

Another object of the invention is to provide means for allowing air to pass completely around the fuse link.

A further object of the invention is to provide an improved form of fuse link.

Other and further important objects of this invention will be apparent from the disclosures in the specification and drawings.

The invention (in a preferred form) is illustrated in the drawings and hereinafter more fully described.

On the drawings:—

Figure 1 is a side elevation of a fuse plug embodying the features of the present invention.

Figure 2 is a section on the line 2—2 of Figure 1.

Figure 3 is a plan view of the plug.

Figure 4 is a section on the line 4—4 of Figure 2.

Figure 5 is an axial section through the fuse carrier, with parts in elevation.

Figure 6 is a section on the line 6—6 of Figure 4, and

Figure 7 is a view taken on the line 7—7 of Figure 4.

As shown in the drawings:—

The plug comprises a threaded metallic cup 1 to the upper part of which is attached a cylindrical block 2 of insulating material. This block may conveniently consist of hard rubber which is molded around the upper part of the cup and formed with vertical flutings 3 to aid the rotation of the plug in its socket.

Lateral projections 4 on the upper end of the cup may be provided to prevent detachment of the insulation 2 from the cup 1.

Centrally and detachably arranged within the cup 1, is a fuse carrier 5 comprising a central cylindrical portion 6 of insulating material and metallic end pieces 7 and 8 screwed or cast into each end. For connecting this carrier 5 to the cup 1 the end piece 7 may be provided with an extension 18 of reduced size adapted to fit snugly within a cylindrical recess 9 in the end of the cup. The outer end piece is conveniently dished at its end, as at 15, for better engagement with the central contact of a socket.

A fuse 11 may be detachably secured to one side of the carrier 5 by any suitable means such as split rings 10, which clamp the ends of the strip to the two metallic end pieces 7 and 8.

Preferably movement of these rings towards the center of the carrier is limited by providing longitudinal ribs 12 on the central insulating portion 6 of the carrier.

Although various forms of fuse strip may be employed I prefer to use a strip having a series of portions 13 of reduced width as shown more particularly in Figure 2. The cross-section of these portions 13 determines the current strength at which the fuse will blow and by providing a plurality of such sections arcing is avoided since one or more of the intermediate parts of the fuse will fall when the sections 13 above and below it fuse, thereby producing a much wider gap than would be produced by the fusing of a single section 13.

Preferably provision is made for allowing free circulation of air all around the parts 13 of the fuse strip and in the form of construction shown this is accomplished by forming a series of circumferential grooves 14 in the insulating part 6 of the carrier

adapted to register with the parts 13 of the fuse strip.

The operation is as follows:

The fuse carrier 5 is detached from the plug and the rings 10 slipped off the ends. A fuse strip 11 is then laid along one side of the carrier with its parts 13 registering with the grooves 14. The rings are now slipped over the ends of the carrier to clamp the ends of the fuse link to the end pieces 7 and 8.

Next the carrier is connected to the cup 1 by thrusting the extension 18 into the recess 9 by which it is frictionally held.

The plug is now ready to screw into the fuse cutout box.

I am aware that numerous details of construction may be varied through a wide range without departing from the principles of this invention and I therefore do not purpose limiting the patent granted further than necessitated by the prior art and the annexed claims.

I claim as my invention:—

- 25 1. A fuse comprising a cylinder having metallic end portions and an intermediate portion of insulating material and split metallic rings for detachably securing a strip of fusible material along one side of the cylinder with its ends in contact with the metallic end portions, said cylinder being provided with a longitudinal ridge adapted to prevent displacement of the split metallic rings.
- 35 2. A fuse plug comprising a threaded metallic shell, a cylinder arranged concentrically within the shell having metallic end portions and an intermediate circumferentially grooved portion of insulating material, one end portion being electrically connected

with the shell and the other being adapted for electrical connection with a contact in a socket, a strip of fusible material having a portion of reduced width and split metallic rings for securing said strip along one side of the cylinder with its ends in contact with the metallic end portions and its portion of reduced width in register with the groove in the cylinder.

3. A fuse plug comprising a cylinder closed at one end, a cylinder of insulating material disposed therein, a fuse carried on the outside of the second cylinder, said assembly forming an open air space between the cylinders.

4. A fuse plug comprising a cylinder, closed at one end, another cylinder of insulating material frictionally held therein, a fuse carried on the outside of the second cylinder, said assembly forming an open ended air space between the cylinders.

5. In a fuse plug, a hollow cylinder of sheet metal closed at one end and open at the other, the side wall of said cylinder toward the open end being formed into a screw thread to fit a standard socket, a head of insulating material surrounding the unthreaded part of said wall and covering the closed end of said cylinder, a hollow projection on said closed end extending into said head, and a fuse frictionally engaging the inside of said projection and supported thereby.

In testimony whereof I have hereunto subscribed my name in the presence of two subscribing witnesses.

JOHN B. GLOWACKI.

Witnesses:

CHARLES W. HILLS, Jr.,  
EARL M. HARDINE.