

E. S. Piner,

Grinding Hand-Saws,

No 111, 117,

Patented Jan. 24, 1871.

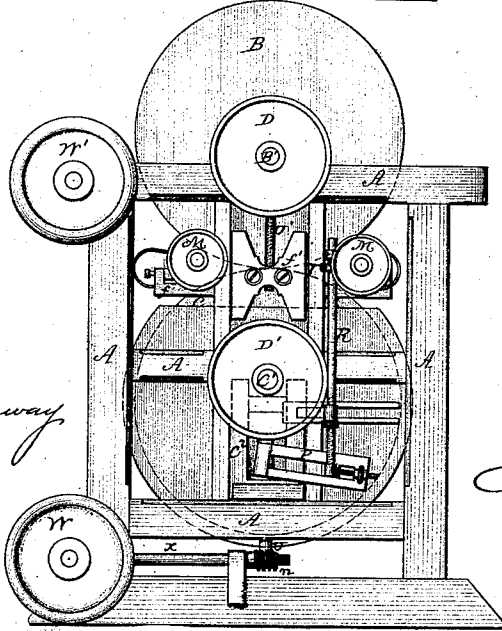
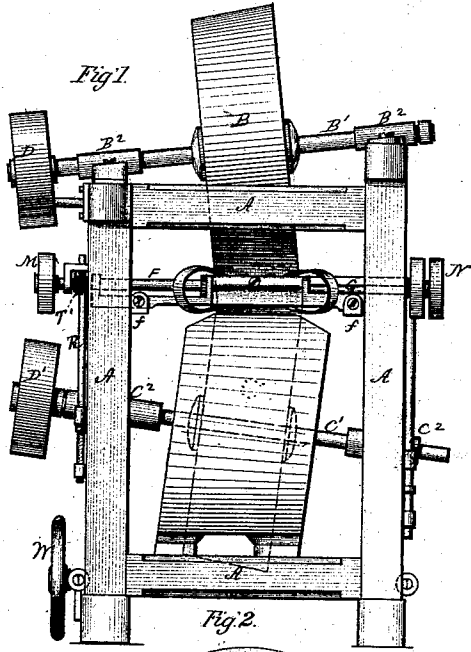

Witnesses
J. H. Shumway
W. J. Tibbets

Edwin S. Piner
 Inventor
 By *Geo. A. Conroy*
John E. Earle

L. S. Filer,

27, Steele's, Street, E.

Grinding Hand Saws.

No. 111, 117.

Patented Jan. 24, 1871.

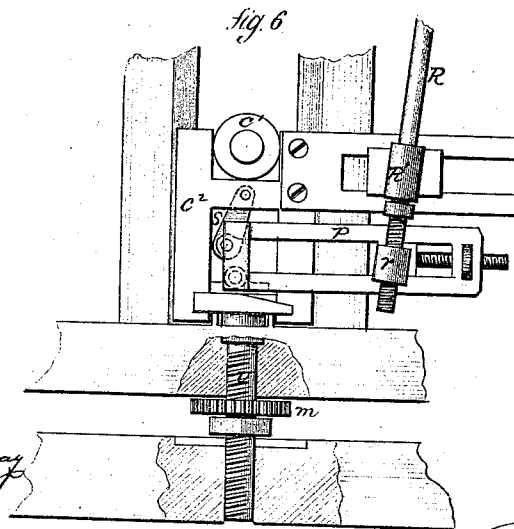
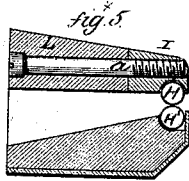
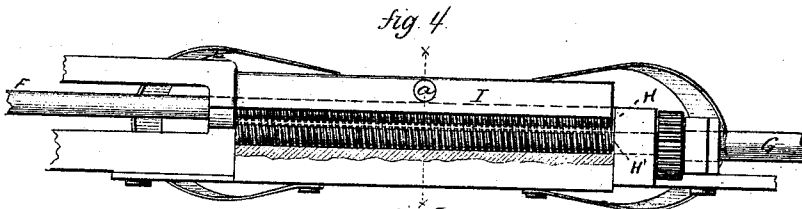
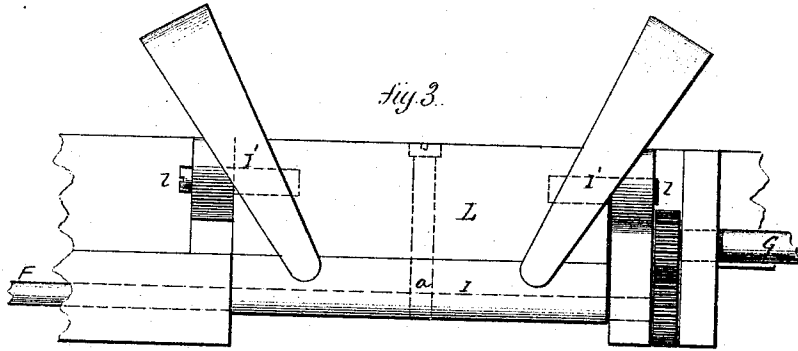

Witnesses.

J. H. Sumnerway
A. J. Tibbitts

Edwin S. Fisher
Inventor
By his Attorney,
John S. Earle

United States Patent Office.

EDWIN S. PIPER, OF ROCHESTER, NEW YORK.

Letters Patent No. 111,147, dated January 24, 1871.

IMPROVEMENT IN MACHINES FOR GRINDING HAND-SAWS.

The Schedule referred to in these Letters Patent and making part of the same.

To all whom it may concern :

Be it known that I, EDWIN S. PIPER, of Rochester, in the county of Monroe and State of New York, have invented a new Improvement in Machines for Grinding Hand-Saws; and I do hereby declare the following, when taken in connection with the accompanying drawing and the letters of reference marked thereon, to be a full, clear, and exact description of the same, and which said drawing constitutes part of this specification, and represents in

Figure 1 a front view;

Figure 2, a side view; and in

Figures 3, 4, 5, and 6, detached views to illustrate the construction and operation.

This invention relates to an improvement in machines for grinding saw-plates, the object being the construction of a machine which shall be self-adjusting, so as to automatically bring the saw-plate to the required thickness from one end to the other.

Such plates are formed of an even thickness upon the toothed edge, diminishing in thickness toward the back slightly at the heel, and gradually thinning on the back from the heel to the point.

My invention consists—

First, in a compound adjustment of the feeding-rolls.

Second, in an automatic arrangement for adjusting the inclination of the axles of the stones so as to give the increasing thickness to the back of the saw from the point to the heel.

A is the frame which supports the operative mechanism;

B is the upper stone; and

C, the lower stone, hung upon their respective axles B¹ and C¹, and so as to revolve freely on bearings B² and C², the said bearings being constructed so as to rock and operate at different inclinations, and the two stones caused to revolve by the application of power through the pulleys D and D¹.

The face of the stones is made conical, corresponding to the inclination at which they are set, so that the two faces may lie parallel to each other. This gives to the stones an increasing diameter from one end to the other, and, revolving upon the work, imparts as it were, a sliding grind, but yet the work ground in a straight line from end to end, and without wavering, as with stones which are hung with parallel axles.

The feeding device consists of two rolls, the one driven by the shaft F and the other by the shaft G, shown enlarged in figs. 3 and 4.

The shaft F, to which one roll H (see fig. 4) is fixed, is hung in a bar, I, (see figs. 3, 4, and 5,) the said bar being pivoted transversely at *a* to a second bar, L, and the bar L pivoted longitudinally at *l*, (see fig. 3,) so that, by means of the bar L, the roll may be raised

vertically, and by the pivot *a* a transverse inclination may be given to the roll to correspond to the irregularities on the surface of the saw-plate, by this construction giving a compound or universal movement to the feeding-rolls.

The feeding-rolls are caused to revolve by the application of power thereto through the pulleys M and N.

One of these feeding devices is arranged on each side of the stones, as seen in fig. 2, so that a saw fed in at one side is carried through between the stones into the feeding device at the other side, and by the last drawn through when the first shall have ceased to act—that is, when the plate has passed out of the first device.

Upon the bar I, springs I' are arranged so as to bear the upper roll upon the lower, and yet allow the roll to automatically adjust to the surface of the saw-plate.

The feed-rolls H and H' are threaded, so that, by the revolving of the rolls to draw in the saw-plate, the screw-thread on the rolls will work off from the plate the mud which will accumulate on the surface of the plate during the process of grinding.

The feeding devices are supported upon bars, *f*, and these bars are fixed to a slide, *f'*, upon opposite sides of the frame, and these slides are raised up or down, as may be required, to set the feeding device relatively to the stones, and this I do by screws, U, operated by a hand-wheel, W, connected by suitable gearing with the said screws.

In grinding saws, it is necessary that the point be thin at the back, gradually increasing toward the heel, while the edge remains of an even thickness from heel to point. To do this it is necessary to change the position of the stones or inclination of their axles, and with this object I fix a lever, P, (seen enlarged in fig. 6,) with a toggle, *s*, beneath the bearings of the lower shaft, and connect the lever by a shaft, R, to a pinion T, operated by a worm, T', on the shaft F, the lower end of the shaft R being threaded and working in a nut, *r*, adjustably arranged in the lever P, so that the shaft F, revolving, operates the lever P to gradually change the inclination of the axle.

The lower end of the shaft R is supported in bearing R', to permit the adjustment of the nut *r* in the lever P to give a greater or lesser throw to the toggle.

The toggle raises or lowers a carriage, C², upon which the bearing C¹ of the lower stone rests, and, as this lever is operated by the feed-rolls, the adjustment of the stone is made to correspond to the movement of the saw-plate between the stones. Therefore, commencing to grind, say at the point, the inclination of the stone is set to give the requisite diminish at the point; as the plate advances by the turning of the feed-rolls, the lower stone will be gradually lowered upon that side where the back of the plate is being

ground, while the other edge will be adjusted to retain the same thickness, and thus the desired form of grinding will be attained.

The bearings for the lower axle are adjusted to bring the stones nearer together or carry them farther apart, by a screw, U, under each carriage, which are operated by a hand-wheel, W, working by suitable gears in a shaft, X, for each screw, and with a worm, n, on each of the said shafts working in a pinion, m, on the said screws.

I arrange, if desired, upon one or both stones, suitable bonnets or shoulders, denoted in the drawing as only upon the lower stone.

I claim as my invention—

1. The feed-rolls H H', one of which is arranged in a universal bearing so as to be self-adjusted to the other, and combined with the grinding apparatus, substantially as set forth.

2. In a grinding apparatus, the arrangement of the toggles s to adjust the bearings of the stones, in connection with the feeding device, substantially in the manner herein set forth.

EDW. S. PIPER.

Witnesses:

CHRIS. GAFFIN,
RICHARD H. SCHOOLEY.