

March 24, 1964

K. F. FRYER

3,125,877

CYLINDER LOCK MOUNTING CONSTRUCTION

Filed Aug. 24, 1961

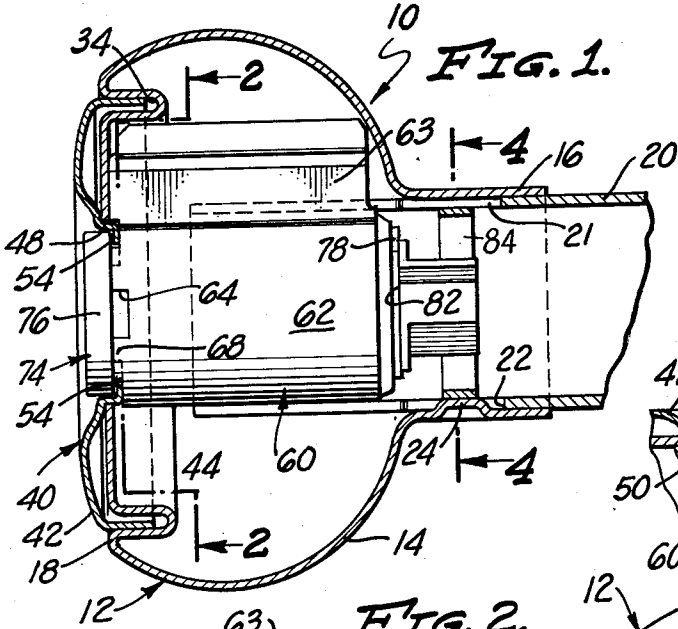

FIG. 1.

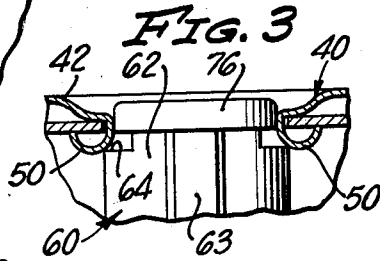

FIG. 3

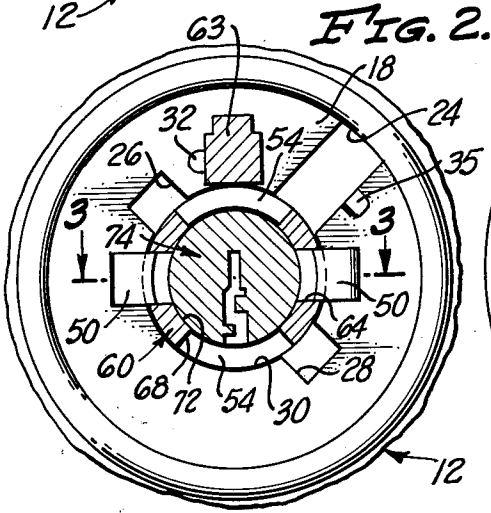

FIG. 2.

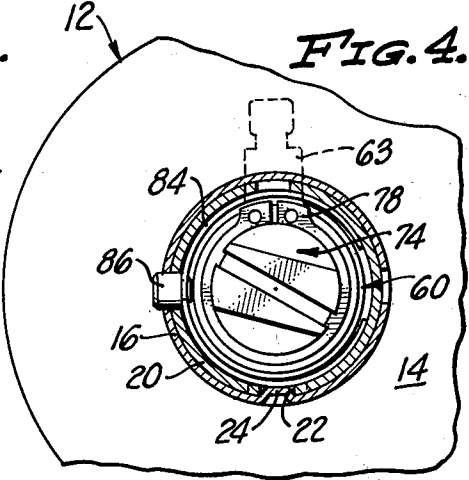

FIG. 4.

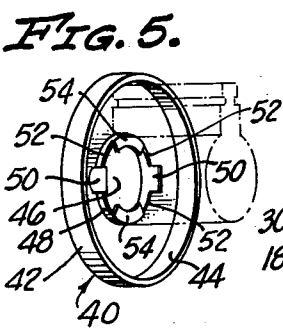

FIG. 5.

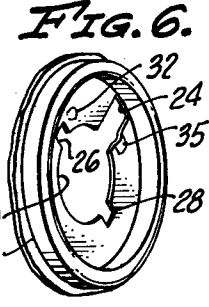

FIG. 6.

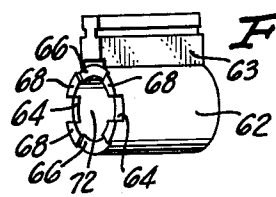

FIG. 7.

INVENTOR.  
**KENNETH F. FRYER**  
 BY  
*Thomas P. Mahoney*  
 ATTORNEY

1

3,125,877

**CYLINDER LOCK MOUNTING CONSTRUCTION**

Kenneth F. Fryer, Anaheim, Calif., assignor to The American Hardware Corporation, New Britain, Conn., a corporation of Connecticut

Filed Aug. 24, 1961, Ser. No. 133,596

10 Claims. (Cl. 70-224)

This invention relates to a cylinder lock mounting construction and, more particularly, to a cylinder lock mounting adapted to be utilized in conjunction with a single piece knob whereby a cylinder lock may be mounted and retained in operative relationship with said knob.

Obviously, the retention of a cylinder lock in operative relationship with a knob with which it is associated is of paramount importance since the cylinder lock must be easily insertable in operative relationship with the knob but must also be easily removable from operative relationship therewith in order to permit the modification thereof or substitution of another lock therefor. A mounting and retention problem for cylinder locks is encountered, particularly, in one-piece knobs having shanks or necks whose diameter will not permit a cylinder and plug assembly to pass therethrough. Therefore, the cylinder lock must be mounted from the front end or face of the knob and my invention is directed to the accurate and easy mounting of cylinder locks in such one-piece knobs.

It is, therefore, an object of my invention to provide a cylinder lock knob construction which is characterized by the relative ease with which a cylinder lock can be mounted in operative relationship with said knob by merely inserting the cylinder lock through an opening in the front face of the knob and displacing a portion of the cylinder lock with respect to the front face and said opening.

Another object of my invention is the provision of a cylinder lock mounting which is characterized by the fact that the cylinder lock is associated with a cover or face plate adapted to be disposed in overlying relationship with the front face or outer extremity of the associated knob, said face plate being secured against rotation relative to said lock by cooperating detent means on said lock and said face plate.

Another object of my invention is the provision in a knob construction of the aforementioned character, of a cylinder lock adapted to be inserted through a corresponding opening in the front face of the knob, said cylinder lock having a face or cover plate mounted thereupon and restrained against rotation relative thereto and said plate having a retention means thereupon engageable with portions of the front face of said knob adjacent said opening.

A further object of my invention is the provision, in a knob construction of the aforementioned character, of stop means on the front end or face of the knob body adapted to prevent movement of the cylinder lock with respect to the knob body beyond a predetermined position therein.

An additional object of my invention is the provision of a cylinder lock mounting for a one-piece knob having an opening in the front face thereof, said mounting including a cover plate secured to one extremity of the cylinder lock against relative rotation with respect to said cylinder lock, and said cover plate including retention means adapted to engage upon the interior surface of the front face of said knob to retain said lock in said knob.

Other objects and advantages of my invention will be apparent from the following specification and the accompanying drawing, which is for the purpose of illustration only, and in which:

FIG. 1 is a longitudinal sectional view of a lock mount-

2

ing construction manufactured in accordance with the teachings of my invention;

FIG. 2 is a vertical sectional view taken on the broken line 2-2 of FIG. 1;

FIG. 3 is a transverse, fragmentary, sectional view taken on the broken line 3-3 of FIG. 2;

FIG. 4 is a vertical sectional view taken on the broken line 4-4 of FIG. 1;

FIG. 5 is a perspective view of the cover or face plate;

FIG. 6 is a fragmentary, perspective view of the rear portion of the front face of the knob; and

FIG. 7 is a perspective view of the cylinder lock housing.

Referring to the drawing, and particularly to FIGS. 1-3 thereof, I show a knob construction 10 manufactured in accordance with the teachings of my invention and including a one-piece sheet metal knob 12 having a body 14 which includes a cylindrical shank 16 and a front end or face 18. The shank 16 is adapted to be mounted in encompassing relationship with a knob spindle 20, said spindle incorporating radial slots 21 and 22. Formed in the shank 16 is a projection or lance 24 which is adapted to engage in the lower slot 22 in the spindle 20 to permit rotation of the spindle 20 by the knob 12. If the knob 12 is reversed, the lance 24 will engage in the slot 21.

The front face or end 18 of the knob body 14 incorporates a plurality of radial openings or slots including a centrally located slot 24 and smaller slots 26 and 28 which communicate with a centrally located opening 30 in said front face. A protuberance 32 is formed on the interior wall of the front face 18 of the knob 12 and constitutes a stop, for a purpose which will be described in greater detail below. The front face 18 of the knob 12 also includes an annular depression or groove 34. Located adjacent the larger slot 24 is an abutment 35 which is adapted to perform a function to be described in greater detail below.

A cylinder lock mounting assembly 40 is adapted to be disposed in operative relationship with the knob 12 and includes a circular cover plate 42 which incorporates a peripheral flange 44 adapted to project into the corresponding annular groove 34 in the front face 18 of the knob 12. The cover or face plate 42 has a centrally located opening 46 therein which is defined by a perimetrical, right-angular, flange 48 extending rearwardly through the opening 30 in the front face 18 of the knob 12 when the cover plate 42 is assembled in operative relationship with said knob.

The flange 48 incorporates a pair of radially extending retention tabs 50 and a plurality of detent openings 52, as best shown in FIGS. 2 and 5 of the drawing. The remaining portions 54 of the flange 48 serve to retain a cylinder lock 60 in operative relationship with the face plate or cover 42, in a manner to be described in greater detail below.

The cylinder lock 60 includes a housing or cylinder 62 having a radially projecting tumbler chamber 63 formed integrally therewith. The forward extremity of the cylinder 62 is, as best shown in FIGS. 1 and 7 of the drawing, provided with oppositely disposed radial slots 64 and 66 which define radial detents 68 on said forward extremity.

Located in the bore 72 of the cylinder 62 is a rotatable key-receiving plug 74 which has a head 76 adapted to overlie the radial slots 64 and 66 provided in the forward extremity of the cylinder 62 of the cylinder lock 60. The rearward extremity of the plug 74 is retained in operative relationship with the cylinder 62 by means of a snap ring 78 located in a slot 82 in said rearward extremity as best shown in FIG. 1 of the drawing.

In assembling the mounting assembly 40 the cover plate

3

42 is located in overlying relationship with the forward extremity of the cylinder 62 and the radial detents 68 on the forward extremity of the cylinder 62 are located in the detent openings or slots 52 provided in the perimetrical flange 48 on the face plate 42. The radially extending tabs 50 on the face plate 42 are located in the corresponding radial slots 64 on the cylinder 62 and the remaining portions 54 of the perimetrical flange 48 are located in the openings 66 on the forward extremity of the cylinder 62.

The plug 74 is then inserted through the bore 72 of the cylinder 62 and the snap ring 78 installed open the rearward extremity thereof. Therefore, the interengagement of the radial detents 68 with the radial slots or openings 52 in the flange 48 of the face plate 42 prevents relative rotation between the cylinder lock 60 and the face plate 42, while the location of the remaining portions 54 of the flange 48 in the openings 66 of the cylinder 62 behind the head 76 of the plug prevents axial displacement of the cylinder lock 60 from operative engagement with the face plate 42.

When the mounting assembly 40 is inserted into operative relationship with the front face 18 of the knob body 14, the cylinder is located in the centrally located opening 30 of the front face 18 of the knob body 14 with the tumbler housing 63 disposed in registry with the largest slot 24 of the plurality of slots or openings in said front face. Registration of the tumbler housing 63 with the opening 24 will cause corresponding registry of the radially extending tabs 52 with the openings or slots 26 and 28. The cylinder 62 can then be pushed rearwardly into the body 14 of the knob 12 until the forward extremity of the tumbler housing 63 is located rearwardly of the interior surface of the front face 18 of the knob body 14 and until the radially extending tabs 52 are also disposed rearwardly of said interior surface.

When the cylinder 62 has been so located, the face plate 42 may be rotated in a counterclockwise direction as viewed in FIG. 2 of the drawing to urge the tumbler housing 63 against the stop 32. The abutment 35 prevents rotation of the cylinder lock housing 62 in a clockwise direction, as viewed in FIG. 2 of the drawing, because the tumbler chamber 63 will impinge thereupon. Rotation of the face plate 42 causes corresponding rotation of the cylinder 62 and causes the radially extending tabs 50 to engage the interior surface of the front face 18 of the knob body 14 in the manner best shown in FIG. 2 of the drawing. Location of the tabs 50 in this manner prevents axial displacement of the mounting assembly 40 from operative engagement from the knob body 14.

After the cylinder lock 60 has been located, by the use of the mounting assembly 40, in the above-described manner, the knob 12 can be installed upon the spindle 20 with the projection 24 on the shank 16 engaged in the lower slot 22. The tumbler housing 63 of the cylinder lock 60 is received in the upper slot 21 and restrained from relative rotation with respect to the spindle 20. A latch 86 is biased by a spring 84 through corresponding openings in the spindle 20 and shank 16 to restrain the knob body 14 from axial displacement with respect to the spindle 20.

Removal of the mounting assembly 40 from operative engagement with the knob 12 merely entails a reversal of the steps of assembly set forth hereinabove in that the knob 12 is removed from operative engagement with the spindle 20 by disengagement of the latch 86 from the corresponding openings in the shank 16 of the knob 12 and the spindle 20. When the knob has been removed from the spindle 20, the face plate 42 is rotated to juxtapose the tumbler housing 63 with the slot 24 in the front face 18 of the knob 14 which permits removal of the cylinder 62 from the knob 12.

By my invention, I provide a cover plate which is locked to and rotates with the cylinder lock thus eliminating the necessity for interengagement of lock portions with the face plate during the installation of the lock. More-

4

over, the provision of the tabs on the face plate secures the face plate and the lock mounted therein against displacement from the knob.

Therefore, quicker and more positive installation or removal of the lock mounting assembly is achieved. Furthermore, replacement of the cover plate at any time or of the lock upon the cover plate is always possible because the release of the plug from the cylinder of the lock immediately permits separation of the cover plate from the lock.

Furthermore, since the cylinder lock is supported completely within the knob, there is no necessity for removing the entire lockset from the associated door when it is necessary to reverse, rekey, or replace the cylinder lock.

I claim:

1. In a cylinder lock mounting construction, the combination of: a cylinder lock including a housing, a tumbler chamber formed integrally with said housing and a plug mounted for rotation in said housing, said housing having detents on its forward extremity and said plug having a forward extremity overlying said detents; a face plate mounted on said lock at its forward extremity and rearwardly of the forward extremity of said plug, said face plate having detent openings engageable by said detents on said forward extremity of said housing; and a hollow knob body having a front face with an opening therein corresponding to the cross-sectional configuration of said cylinder lock housing, said front face having a stop thereupon engageable by said cylinder lock housing when said cylinder lock housing is rotated within said knob with respect to said opening.

2. In a cylinder lock mounting construction, the combination of: a hollow knob body having a front face incorporating a central opening and a plurality of openings communicating with said central opening; a cylinder lock having a housing whose cross-sectional configuration is substantially identical with the configuration of said central opening and one of said openings communicating with said opening in said front face, said cylinder lock housing incorporating a plurality of detents at its forward extremity and a rotatable plug having a head overlying said detents; and a face plate disposed in overlying relationship with said front face of said knob, said face plate having a central opening adapted to receive said plug and incorporating a plurality of detent openings for the reception of said housing detents, said face plate having retention means thereupon insertable through certain of said openings in said front face of said knob and overlying the interior surface of said front face when said housing is rotated within said knob.

3. In a cylinder lock mounting construction, the combination of: a hollow knob body having a front face incorporating a central opening and a plurality of openings communicating with said central opening; a cylinder lock including a housing, a tumbler chamber formed integrally with said housing and a plug mounted for rotation in said housing, said housing having detents on its forward extremity, and said plug having a forward extremity overlying said detents; a face plate mounted on said lock at its forward extremity and rearwardly of the forward extremity of said plug, said face plate having detent openings engageable by said detents on said forward extremity of said cylinder lock housing, said front face having a stop thereupon engageable by said cylinder lock housing when said cylinder lock housing is rotated within said knob with respect to said opening and having retention means thereupon insertable through certain of said openings in said front face of said knob and overlying the interior surface of said front face when said housing is rotated within said knob, said retention means being constituted by tabs on said face plate overlying the interior surface of said front face.

4. In a cylinder lock mounting construction, the combination of: a hollow knob body having a front face incorporating a central opening and a plurality of openings

5

communicating with said central opening, said front face having a stop formed on its interior surface, a cylinder lock having a housing whose cross-sectional configuration is substantially identical with the configuration of said central opening and one of said openings communicating with said opening in said front face, said cylinder lock housing incorporating a plurality of detents at its forward extremity and a rotatable plug having a head overlying said detents; and a face plate disposed in overlying relationship with said front face of said knob, said face plate having a central opening adapted to receive said plug and incorporating a plurality of detent openings for the reception of said housing detents, said face plate having retention means thereupon insertable through certain of said openings in said front face of said knob and overlying the interior surface of said front face when said housing is rotated within said knob, said housing being engageable with said stop to limit rotation of said housing and said retention means with respect to said openings in said front face of said knob.

5. In a cylinder lock mounting construction adapted to be utilized in conjunction with a hollow knob having a front face incorporating a centrally located opening and a plurality of slots communicating with said opening, the combination of: a cylinder lock including a housing whose cross-sectional configuration conforms substantially to the shape of said centrally located opening and one of said slots in said front face of said knob, said housing having a detent at its forward extremity and incorporating a rotatable plug having a head at its forward extremity overlying said detent; and a face plate mounted on said cylinder lock rearwardly of said head of said plug, said face plate having a detent receiving opening therein adapted to receive said detent on the forward extremity of said housing to prevent relative rotation between said lock and said face plate when said lock and face plate are installed in operative relationship with said knob.

6. In a cylinder lock mounting construction adapted to be utilized in conjunction with a hollow knob having a front face incorporating a centrally located opening and a plurality of slots communicating with said opening, the combination of: a cylinder lock including a housing whose cross-sectional configuration conforms substantially to the shape of said centrally located opening and one of said slots in said front face of said knob, said housing having a detent at its forward extremity and incorporating a rotatable plug having a head at its forward extremity overlying said detent; and a face plate mounted on said cylinder lock rearwardly of said head of said plug, said face plate having a detent receiving opening therein adapted to receive said detent on the forward extremity of said housing to prevent relative rotation between said lock and said face plate when said lock and face plate are installed in operative relationship with said knob, said face plate having retention means thereupon insertable through certain of said slots in said front face of said knob to retain said lock and face plate against axial displacement from said knob after said lock and face plate have been rotated to dispose said housing and retention means out of register with said slots.

7. In a cylinder lock mounting construction adapted to be utilized in conjunction with a hollow knob having a front face incorporating a centrally located opening and a plurality of slots communicating with said opening, the combination of: a cylinder lock including a housing whose cross-sectional configuration conforms substantially to the shape of said centrally located opening and one of said slots in said front face of said knob, said housing having a detent at its forward extremity and incorporating a rotatable plug having a head at its forward extremity overlying said detent; and a face plate mounted on said cylinder lock rearwardly of said head of said plug, said face plate having a detent receiving opening therein adapted to receive said detent on the forward

6

extremity of said housing to prevent relative rotation between said lock and said face plate when said lock and face plate are installed in operative relationship with said knob, said face plate having retention means thereupon insertable through certain of said slots in said front face of said knob to retain said lock and face plate against axial displacement from said knob after said lock and face plate have been rotated to dispose said housing and retention means out of register with said slots, said retention means being constituted by radially extending tabs engageable with the interior surface of said front face of said knob.

8. In a cylinder lock mounting construction adapted to be utilized in conjunction with a knob having a front face incorporating a centrally located opening and a plurality of slots communicating with said opening, the combination of: a cylinder lock including a housing and a plug rotatable in said housing, said lock having a detent thereupon at the forward extremity thereof; and a face plate mounted on the forward extremity of said lock adapted to be disposed in overlying relationship with said front face of said knob, said face plate having a detent recess therein engageable by said detent on said lock to prevent relative rotation between said lock and said face plate.

9. In a cylinder lock mounting construction adapted to be utilized in conjunction with a knob having a front face incorporating a centrally located opening and a plurality of slots communicating with said opening, the combination of: a cylinder lock including a housing whose cross-sectional configuration is substantially the same as the cross-sectional configuration of said opening and one of said slots to facilitate the insertion of said housing through said opening and said one slot into the interior of said knob, said housing incorporating a rotatable plug having a head at its forward extremity projecting from said housing and said housing incorporating detents at its forward extremity; and a face plate disposed in overlying relationship with said front face of said knob, said face plate being mounted on said lock adjacent the forward extremity of said housing and including a plurality of detent-receiving recesses engageable by said detents on the forward extremity of said housing to prevent relative rotation between said lock and said face plate.

10. In a cylinder lock mounting construction adapted to be utilized in conjunction with a knob having a front face incorporating a centrally located opening and a plurality of slots communicating with said opening, the combination of: a cylinder lock including a housing whose cross-sectional configuration is substantially the same as the cross-sectional configuration of said opening and one of said slots to facilitate the insertion of said housing through said opening and said one slot into the interior of said knob, said housing incorporating a rotatable plug having a head at its forward extremity projecting from said housing and said housing incorporating detents at its forward extremity; and a face plate disposed in overlying relationship with said front face of said knob, said face plate being mounted on said lock adjacent the forward extremity of said housing and including a plurality of detent-receiving recesses engageable by said detents on the forward extremity of said housing to prevent relative rotation between said lock and said face plate, said face plate having retention tabs thereupon adjacent said recesses, said retention tabs being insertable through certain of said slots and, when said lock is rotated within said knob, being adapted to engage the interior surface of said front face of said knob to prevent axial displacement of said lock and said face plate from said knob.

#### References Cited in the file of this patent

##### UNITED STATES PATENTS

2,040,258	Jacobi	May 12, 1936
2,079,583	Brauning	May 4, 1937
2,748,590	Kubik et al.	June 5, 1956