

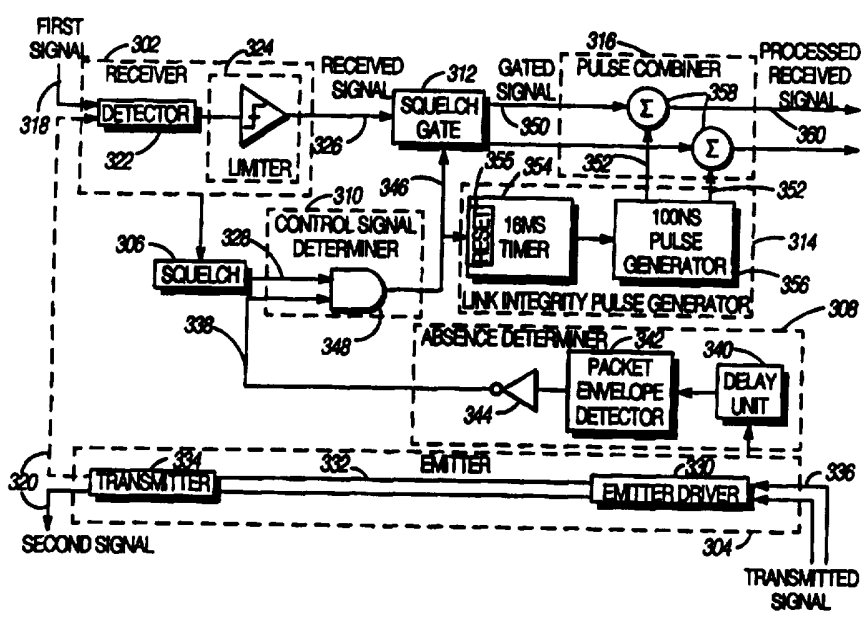

INTERNATIONAL APPLICATION PUBLISHED UNDER THE PATENT COOPERATION TREATY (PCT)

<p>(51) International Patent Classification ⁶ : G08B 5/22, G06F 15/00, H04B 1/52, 1/58, 3/20, 14/04, 10/06, H04J 1/00, 3/00, 15/00, 3/02</p>	<p>A1</p>	<p>(11) International Publication Number: WO 96/20462 (43) International Publication Date: 4 July 1996 (04.07.96)</p>
<p>(21) International Application Number: PCT/US95/13927 (22) International Filing Date: 10 October 1995 (10.10.95) (30) Priority Data: 08/365,615 28 December 1994 (28.12.94) US (71) Applicant: MOTOROLA INC. [US/US]; 1303 East Algonquin Road, Schaumburg, IL 60196 (US). (72) Inventors: EASTMOND, Bruce, Charles; 5931 Brookbank Road, Downers Grove, IL 60516 (US). ALAMEH, Rachid, Mohsen; Apartment #304, 205 Travis Court, Schaumburg, IL 60195 (US). (74) Agents: STOCKLEY, Darleen, J. et al.; Motorola Inc., Intellectual Property Dept., 1303 East Algonquin Road, Schaumburg, IL 60196 (US).</p>		<p>(81) Designated States: AU, CA, CN, European patent (AT, BE, CH, DE, DK, ES, FR, GB, GR, IE, IT, LU, MC, NL, PT, SE). Published <i>With international search report.</i></p>

(54) Title: METHOD, TRANSCEIVER, AND SYSTEM FOR PROVIDING WIRELESS COMMUNICATION COMPATIBLE WITH 10BASE-T ETHERNET



(57) Abstract

The present invention provides a method (200), transceiver (100), and system (900) for providing wireless communication compatible with 10BASE-T Ethernet. In the transceiver, an absence detector receives a transmitted signal, determines an absence of the transmitted signal, and passes the absence to an activity detector in order to differentiate between a reflected signal and a received signal in a half duplex system. The activity detector receives the received signal and determines an operation time signal in which the received signal is absent.

FOR THE PURPOSES OF INFORMATION ONLY

Codes used to identify States party to the PCT on the front pages of pamphlets publishing international applications under the PCT.

AM	Armenia	GB	United Kingdom	MW	Malawi
AT	Austria	GE	Georgia	MX	Mexico
AU	Australia	GN	Guinea	NE	Niger
BB	Barbados	GR	Greece	NL	Netherlands
BE	Belgium	HU	Hungary	NO	Norway
BF	Burkina Faso	IE	Ireland	NZ	New Zealand
BG	Bulgaria	IT	Italy	PL	Poland
BJ	Benin	JP	Japan	PT	Portugal
BR	Brazil	KE	Kenya	RO	Romania
BY	Belarus	KG	Kyrgystan	RU	Russian Federation
CA	Canada	KP	Democratic People's Republic of Korea	SD	Sudan
CF	Central African Republic	KR	Republic of Korea	SE	Sweden
CG	Congo	KZ	Kazakhstan	SG	Singapore
CH	Switzerland	LI	Liechtenstein	SI	Slovenia
CI	Côte d'Ivoire	LK	Sri Lanka	SK	Slovakia
CM	Cameroon	LR	Liberia	SN	Senegal
CN	China	LT	Lithuania	SZ	Swaziland
CS	Czechoslovakia	LU	Luxembourg	TD	Chad
CZ	Czech Republic	LV	Latvia	TG	Togo
DE	Germany	MC	Monaco	TJ	Tajikistan
DK	Denmark	MD	Republic of Moldova	TT	Trinidad and Tobago
EE	Estonia	MG	Madagascar	UA	Ukraine
ES	Spain	ML	Mali	UG	Uganda
FI	Finland	MN	Mongolia	US	United States of America
FR	France	MR	Mauritania	UZ	Uzbekistan
GA	Gabon			VN	Viet Nam

**METHOD, TRANSCEIVER, AND SYSTEM FOR PROVIDING
WIRELESS COMMUNICATION COMPATIBLE WITH
10BASE-T ETHERNET**

5 Field of the Invention

The present invention relates generally to 10BASE-T Ethernet networks, and more particularly to wireless 10BASE-T Ethernet networks.

10

Background of the Invention

Since 1990, the wired local area network defined by IEEE (The Institute of Electrical and Electronics Engineers, Inc.) standard 802.3 10BASE-T, an acronym which stands for 10 Mbit/s, baseband transmission, twisted-pair wiring, has rapidly become preeminent. In addition to its widespread use in new installations, it has, in many cases, supplanted earlier coaxial cable Ethernet and Token-Ring installations. The number of 10BASE-T installations is already large and continues to grow rapidly.

10BASE-T network stations are each connected to a repeater via a duplex, unshielded twisted-pair cable. The repeater accepts a transmitted signal from one station and repeats it to the receivers of all the other stations. This topology facilitates changes and fault location, and the unshielded twisted-pair cable is inexpensive and easy to co-install with telephone wiring. Sixteen-port repeaters of a basic design are easily affordable by small businesses. A local area network repeater may also be connected to a metropolitan area network, wide area network, the Internet, and the proposed "information highway".

Prior to 1993, most stations connected to the 10BASE-T network were desktop personal computers; however, it is becoming increasingly common for portable computing units to be equipped with accessory slots conforming to the PCMCIA standard which can accept credit card-sized 10BASE-T adapters. The users of portable computing units would receive significant benefit from a means for extending the 10BASE-T network to establish communication *ad hoc* among collaborators on a common task, between desktop and portable computers, or with the wired network. Two 10BASE-T stations can form a "network" using a cross-connected cable in which the transmitter of the first station is connected to the receiver of the second station and *vice versa*. However, since n stations require $[n/2] \cdot [n-1]$ duplex twisted-pair cables, it is impracticable for a multi-station *ad hoc* network to be connected in this manner.

The prior art includes a variety of IR, or infrared, and RF, or radio frequency, systems. Prior-art IR systems are limited to less than 10 Mbit/s by either the choice of modulation technique or receiver design limitations or are so directive that it would be difficult or impossible to form a collaborative network of portable computers. Prior art RF systems are either limited by spectrum availability to much less than 10 Mbit/s, or designed for stationary mounting and alternating current powered operation.

The environment of a 10BASE-T network extension is local, which minimizes the range and coverage requirements, as well as the likelihood of "hidden" stations. Thus, either IR optical or microwave radio frequencies are appropriate to convey the Ethernet signal by on-off keyed modulation. On-off keyed modulation is spectrally efficient and simple to generate and detect. Signal emission in an IR optical receiver may employ one or more light-emitting diodes, such as the

Stanley Electric Co., Ltd. DN304, or laser diodes, while signal emission in a microwave RF transmitter may employ a Gunn diode of the type used in law-enforcement speed detectors. Signal detection in an IR optical receiver may employ one or more photodiodes, while signal detection in a microwave RF receiver may employ a Schottky barrier diode. Information transmitted using IR optical signals is inherently private and resistant to interference since most building materials are opaque. In addition, the generation of IR optical signals does not require a license, and safety and international spectrum regulation issues are avoided.

The CSMA/CD, or carrier sense, multiple access with collision detection, protocol specified by the IEEE 802.3 Ethernet standard provides for greater network throughput by quickly aborting transmissions involved in collisions, or simultaneous transmissions by two transmitters. The protocol determines that a collision has occurred when a station detects the presence of a valid signal on its receiving pair during the time that its transmitting pair is active. In the wired 10BASE-T environment, it is certain that the colliding signal originates from a second station. However, if the transmitting and receiving pairs of each station are not connected to the repeater but to a wireless emitter and receiver, respectively, then the wireless receiver will often respond to its own emitter due to reflection from nearby objects or surfaces. Under this condition, the 10BASE-T hardware and protocol will identify every transmission as a collision, the collision protocol will be continuously engaged, and the network will become inoperative. Thus, standard 10BASE-T Ethernet hardware and protocol is inadequate when the wire transmission medium is replaced with a wireless transmission medium.

The 10BASE-T Ethernet protocol also provides for verifying the integrity of the twisted-pair connection between the network station and repeater by sending link integrity pulses having a duration of 100 nanoseconds at 16 millisecond intervals during the time when no data is being transmitted. If neither a data packet nor a link integrity pulse is received for a typical duration of 110 ms, then the protocol enters the link test fail state, and the transmit and receive functions are inhibited. When either a data packet or, typically, four consecutive link integrity pulses are received, then the Ethernet adapter will exit the link test fail state and re-enable the transmit and receive functions. Since a wireless receiver may not respond reliably to an isolated 100 nanosecond pulse, and many Ethernet adapters do not provide for disabling the link integrity test function, the 10BASE-T Ethernet link test will inhibit operation of the network if it is used in the wireless environment.

Accordingly, there is a need for a wireless method, transceiver and system which is compatible with a standard, twisted-pair 10BASE-T Ethernet interface or card so that the wired and wireless environments can be made equivalent. If such a wireless method, transceiver and system were available then file-sharing and communications capabilities could be user-defined by the same operating system or networking software in either the wired or the wireless environment. Moreover, wireless access to the wired 10BASE-T local area network would be greatly simplified since no protocol or data rate translation would be required.

30

Brief Description of the Drawings

FIG. 1 is a block diagram of a preferred embodiment of a transceiver which provides wireless communication

compatible with 10BASE-T Ethernet in accordance with the present invention.

5 FIG. 2 is a flow diagram of steps for implementing a preferred embodiment of a method for providing wireless communication compatible with 10BASE-T Ethernet in accordance with the present invention.

10 FIG. 3 is a block diagram of an alternative embodiment of a transceiver which provides wireless communication compatible with 10BASE-T Ethernet in accordance with the present invention.

15 FIG. 4 is a flow diagram of steps for implementing an alternative embodiment of a method for providing wireless communication compatible with 10BASE-T Ethernet in accordance with the present invention.

20 FIG. 5 is a flow diagram, shown in greater detail, of one embodiment of a step from FIG. 4 for providing, by a receiver, for a reception of a first signal and a second signal to provide a received signal in accordance with the present invention.

25 FIG. 6 is a flow diagram, shown in greater detail, of one embodiment of a step from FIG. 4 for determining, by a presence determiner, the presence of the second signal in accordance with the present invention.

30 FIG. 7 is a flow diagram, shown in greater detail, of one embodiment of a step from FIG. 4 for receiving, by the emitter, a transmitted signal and providing for an emission of the second signal in accordance with the present invention.

35 FIG. 8 is a flow diagram, shown in greater detail, of one embodiment of a step from FIG. 4 for generating, by a link

integrity pulse generator, a link integrity pulse based on the control signal in accordance with the present invention.

FIG. 9 is a block diagram of a system which provides
5 wireless communication compatible with 10BASE-T Ethernet in accordance with the present invention.

Detailed Description of a Preferred Embodiment

10 Generally, the present invention provides a method, transceiver, and system for providing wireless communication compatible with 10BASE-T Ethernet.

FIG. 1, numeral 100, is a block diagram of a preferred
15 embodiment of a transceiver which provides wireless communication compatible with 10BASE-T Ethernet in accordance with the present invention. The transceiver comprises an absence detector (102) and an activity detector (104). A pulse combiner (106) may also be included in the
20 transceiver.

The absence detector (102) receives a transmitted signal (108) for determining an absence (110) of the transmitted signal and passing the absence (110) to the activity detector (104) in order to differentiate between a reflected signal and a received signal (112), in a half duplex system.
25

The activity detector (104) is operably coupled to receive the received signal (112) and to the absence detector (102) for determining an operation time signal (114) in which the received signal is absent.
30

The pulse combiner (106) is operably coupled to receive the received signal (112) and operably coupled to the activity detector (104) for combining a link integrity pulse with the
35

received signal (112) when the operation time signal (114) indicates to provide a 10BASE-T Ethernet compatible signal (116). The pulse combiner (106) is not necessary if the need for a link integrity pulse is overridden in subsequent
5 processing of the 10BASE-T Ethernet compatible signal (116).

FIG. 2, numeral 200, is a flow diagram of steps for implementing a preferred embodiment of a method for providing wireless communication compatible with 10BASE-T
10 Ethernet in accordance with the present invention. The first step is differentiating between a reflected signal originating from a local transmitter and a received signal originating from a remote transmitter, in a half duplex system, by determining an absence of the reflected signal originating
15 from a local transmitter (202). The second step is determining an operation time in which the received signal is absent (204). A final step may be combining a link integrity pulse with the received signal during the operation time to provide a signal compatible with 10BASE-T Ethernet (206).

20
FIG. 3, numeral 300, is a block diagram of an alternate embodiment of a transceiver which provides wireless communication compatible with 10BASE-T Ethernet in accordance with the present invention. The transceiver
25 comprises a receiver (302), an emitter (304), a squelch (306), an absence determiner (308), a control signal determiner (310), a squelch gate (312), a link integrity pulse generator (314), and a pulse combiner (316).

30 The receiver (302) receives a first wireless signal (318) which originates from a point external to the transceiver, and may receive a second wireless signal (320) which originates from the emitter (304). The presence of second wireless signal (320) at receiver (302) depends upon the presence of
35 reflective materials in proximity to transceiver (300). The

receiver includes at least a detector (322) and limiter (324) for producing received signal (326). Limiter (324) produces a binary signal output, with the transition between levels corresponding to first signal (318) or second signal (320) if present; or to detector (322) noise if neither signal is present. If the first and second signals are optical signals, receiver (302) may be as described in Eastmond, *et al.*, "Receiver for Binary Coded Wireless Optical Data", US Patent 5,355,242, issued October 11, 1994 and assigned to Motorola, Inc., which patent is hereby incorporated by reference.

The squelch (306), operably coupled to receiver (302), responds to the presence of first signal (318) or second signal (320) by producing an indication of received signal presence (328). Squelch (306) may determine signal presence from the time distribution of transitions in received signal (326), or from a received signal strength indicator RSSI, known in the art, derived from limiter (324). If the first and second signals are binary encoded data, then squelch (306) may be as described in Alameh, *et al.*, "Method and Apparatus for Detecting Binary Encoded Data", US patent application 08/042,910, filed April 5, 1993, which application is hereby incorporated by reference.

In the emitter (304), emitter driver (330) creates a transmitter control signal (332) for control of transmitter (334) in response to a transmitted signal (336). If the transmitted signal (336) is an Ethernet data signal then it consists of data packets which comprise a plurality of Manchester-encoded bits transmitted at a 10 Mbit/s rate.

The absence determiner (308), operably coupled to receive a transmitted signal (336), produces an indication of second signal absence (338). Absence determiner (308) comprises a time delay (340), having a delay time, t , a packet

envelope detector (342), and an inverter gate (344). The time delay (340) may consist of one or more tandem logic gates, or other means well-known in the art for achieving a delay time, t , which corresponds to the propagation delay experienced by the second signal (320) in passing from transmitter (334) through receiver (302). Packet envelope detector (342) may consist of a monostable multivibrator, resistor-capacitor network, or other means well-known in the art for determining the presence of the transmitted signal envelope. Inverter gate (344) inverts the polarity of the packet envelope detector to produce the indication of second signal absence (338).

The control signal determiner (310) is coupled to absence determiner (308) and to the squelch (306) for producing a control signal (346) based on the simultaneous occurrence of both signal presence (328) and second signal absence (338). The control signal determiner (310) is comprised of a two-input AND gate (348); however, other combinations of standard logic elements may be chosen which are equivalent in operation to the two-input AND gate (348).

The squelch gate (312) coupled to received signal (326) and controlled by control signal (346) operates so that gated signal (350) comprises only the first signal (318). Both the receiver noise and second signal (320) are blocked from the gated signal (350).

The link integrity pulse generator (314), is coupled to control signal (346) for generating 100 nanosecond pulses (352) at 16 millisecond intervals in the absence of control signal (346). The link integrity pulse generator (314) is comprised of a 16 millisecond timer (354) coupled to a 100 nanosecond pulse generator (356). The control signal (346) is connected to a reset (355) of the 16 millisecond timer (354). The 100 nanosecond pulses (352) are each added by a pair of

summers (358) to the gated signal (350) in the pulse combiner (316) to produce a processed received signal (356).

5 FIG. 4, numeral 400, is a flow diagram of steps for implementing an alternative embodiment of a method for providing wireless communication compatible with 10BASE-T Ethernet in accordance with the present invention. The steps include the following: providing, by a receiver, in step (402), for reception of a first signal and a second signal to produce a received signal; determining, by a squelch, in step (404), a presence of the received signal; determining, by an absence determiner, in step (406), the absence of the second signal; providing, by a control signal determiner, in step (408), a control signal based on the presence of the received signal and the absence of the second signal; receiving, by the emitter, in step (410), a transmitted signal and providing for an emission of the second signal; gating, by a squelch gate, in step (412), the received signal based on the control signal to produce a gated signal; generating, by a link integrity pulse generator, in step (414), a link integrity pulse based on the control signal; and adding, by a pulse combiner, in step (416), the pulse to the gated signal to produce a processed received signal compatible with 10BASE-T Ethernet.

25 FIG. 5, numeral 402, is a flow diagram, shown in greater detail, of one embodiment of a step from FIG. 4 for providing, by a receiver, for a reception of a first signal and a second signal to provide a received signal in accordance with the present invention. The flow diagram comprises the following: allowing, by a detector, in step (502), for the reception of at least a first signal, wherein the detector is capable of receiving at least the first signal over an azimuth angle of at least plus and minus 90 degrees; and converting, by a receiver, in step (504), at least the first signal into the received signal, wherein the received signal is an electrical signal.

FIG. 6, numeral 406, is a flow diagram, shown in greater detail, of one embodiment of a step from FIG. 4 for determining, by a presence determiner, the presence of the second signal in accordance with the present invention. The flow diagram comprises the following: providing, by a delay unit, in step (602), a delay with a time duration corresponding to a predetermined mean propagation delay of a reflected signal to the receiver; determining, by a packet envelope detector, in step (604), a presence of the second signal; and inverting, by an inverter gate, in step (606), the presence of the second signal to produce the absence of the second signal.

FIG. 7, numeral 410, is a flow diagram, shown in greater detail, of one embodiment of a step from FIG. 4 for receiving, by the emitter, a transmitted signal and providing for an emission of the second signal in accordance with the present invention. The flow diagram comprises the following: receiving, by an emitter driver, in step (702), the transmitted signal and providing an emitter input and an absence determiner input; and emitting, in step (704), the second signal over an azimuth angle of at least plus and minus 90 degrees.

FIG. 8, numeral 414, is a flow diagram, shown in greater detail, of one embodiment of a step from FIG. 4 for generating, by a link integrity pulse generator, a link integrity pulse based on the control signal in accordance with the present invention. The flow diagram comprises the following: providing, by a timer, in step (802), a 16 millisecond clock for a 100 nanosecond pulse generator based on the control signal; and generating, by the 100 nanosecond pulse generator, in step (804), the link integrity pulse.

FIG. 9, numeral 900, is a block diagram of a system which provides wireless communication compatible with 10BASE-T Ethernet in accordance with the present invention. A first transceiver (904), operably coupled to communication unit (902), receives a second Ethernet transmitted signal (913) from 10BASE-T Ethernet card (912), and transmits a first Ethernet processed received signal (914) to the 10BASE-T card (912). The first transceiver (904) produces the first Ethernet processed received signal (914) in response to first wireless signal (916), and produces a second wireless signal (915) in response to the second Ethernet transmitted signal (913). A second transceiver (906), produces a third Ethernet signal (917) in response to the second wireless signal (915) received from first transceiver (904), and produces the first wireless signal (916) in response to a fourth Ethernet signal (918). An Ethernet bridge (908), operably coupled to second transceiver (906), converts a fifth Ethernet signal (920) received from a 10BASE-T network (910) to the fourth Ethernet signal (918), and converts the third Ethernet signal (917) to a sixth Ethernet signal (919) sent to the 10BASE-T network (910).

A method, transceiver, and system for providing wireless communication compatible with 10BASE-T Ethernet has been described which achieves equivalency in file-sharing and communications capabilities between the wired and wireless environments. Wireless access to a wired 10BASE-T local area network is greatly simplified since no protocol translation is required.

Although exemplary embodiments are described above, it will be obvious to those skilled in the art that many alterations and modifications may be made without departing from the invention. Accordingly, it is intended that all such

alterations and modifications be included within the spirit and scope of the invention as defined in the appended claims.

We claim:

Claims

1. A transceiver for providing wireless communications compatible with 10 BASE-T Ethernet, the transceiver
5 comprising:
- 1A) an absence detector, operably coupled to a transmitted signal, for determining an absence of the transmitted signal and passing the absence to an activity
10 detector in order to differentiate between a reflected signal and a received signal, in a half duplex system; and
- 1B) the activity detector, operably coupled to receive the received signal and to the absence detector, for determining an operation time signal in which the received
15 signal is absent.
2. The transceiver of claim 1, wherein the transceiver further comprises a pulse combiner, operably coupled to receive the received signal and operably coupled to the
20 activity detector, for combining a link integrity pulse with the received signal when the operation time signal indicates to provide a signal compatible with 10BASE-T Ethernet.
3. A method for providing wireless communications compatible with 10 BASE-T Ethernet, the method comprising:
- 25 3A) differentiating between a reflected signal originating from a local transmitter and a received signal originating from a remote transmitter, in a half duplex
30 system, by determining an absence of the reflected signal originating from a local transmitter; and
- 3B) determining an operation time in which the received signal is absent.
35

4. The method of claim 3, wherein the method further comprises a final step of combining a link integrity pulse with the received signal during the operation time to provide a signal compatible with 10BASE-T Ethernet.

5

5. A transceiver for providing wireless communication compatible with 10BASE-T Ethernet, the transceiver comprising:

10 5A) a receiver, operably coupled to receive a first signal and a second signal, for producing a received signal;

5B) a squelch, operably coupled to the receiver, for determining a presence of the received signal;

15

5C) an absence determiner, operably coupled to an emitter, for determining an absence of the second signal;

20 5D) a control signal determiner, operably coupled to the squelch and the absence determiner, for providing a control signal based on the presence of the received signal and the absence of a second signal;

25 5E) the emitter, operably coupled to the absence determiner, for receiving a transmitted signal and providing for an emission of the second signal,

30 5F) a squelch gate, operably coupled to the control signal determiner and receiver, for gating the received signal based on the control signal to produce a gated signal;

35 5G) a link integrity pulse generator, operably coupled to the control signal determiner, for generating a link integrity pulse based on the control signal; and

5H) a pulse combiner, operably coupled to the squelch gate and the link integrity pulse generator, for adding the link integrity pulse to the gated signal to produce a processed received signal compatible with 10BASE-T Ethernet.

5

6. The transceiver of claim 5, wherein at least one of 6A-6H:

6A) the first signal and the second signal are transmitted using on-off keyed modulation;

10 6B) the first signal and the second signal are optical signals;

6C) the first signal and the second signal are microwave radio frequency signals;

6D) wherein the absence determiner further comprises:

15 6D1) a delay unit for providing a delay with a time duration corresponding to a predetermined mean propagation delay of a reflected signal to the receiver;

6D2) a packet envelope detector, operably coupled to the delay unit, for determining a presence of the second signal; and

20

6D3) an inverter gate, operably coupled to the packet envelope detector, for inverting the presence of the second signal to produce the absence of the second signal;

6E) the control signal determiner is an AND gate;

25 6F) wherein the emitter further comprises:

6F1) an emitter driver for receiving the transmitted signal and providing an emitter input and an absence determiner input; and

30

6F2) a transmitter, operably coupled to the emitter driver, for emitting the second signal over an azimuth angle of at least plus and minus 90 degrees;

6G) wherein the link integrity pulse generator further comprises:

6G1) a timer for providing a 16 millisecond clock for a 100 nanosecond pulse generator based on the control signal; and

5 6G2) a 100 nanosecond pulse generator, operably coupled to the timer, for generating the link integrity pulse;

6H) wherein the receiver further comprises:

10 6H1) a detector for allowing for a collection of at least a first signal, wherein the detector is capable of receiving at least the first signal over an azimuth angle of at least plus and minus 90 degrees; and

6H2) a receiver, operably coupled to the detector, for converting at least the first signal into the received signal, wherein the received signal is an electrical signal;

and where further selected, at least one of 6H3-6H4:

15 6H3) wherein the detector is comprised of at least a first photodiode; and

6H4) wherein the detector is comprised of a Schottky barrier diode.

20 7. A method for providing wireless communication compatible with 10BASE-T Ethernet, the method comprising:

7A) providing, by a receiver, for a reception of a first signal and a second signal to provide a received signal;

25

7B) determining, by a squelch, a presence of the received signal;

30 7C) determining, by an absence determiner, an absence of the second signal;

7D) providing, by a control signal determiner, a control signal based on the presence of the received signal and the absence of the second signal;

35

7E) receiving, by an emitter, a transmitted signal and providing for an emission of the second signal;

5 7F) gating, by a squelch gate, the received signal based on the control signal to provide a gated signal;

7G) generating, by a link integrity pulse generator, a link integrity pulse based on the control signal; and

10 7H) adding, by a pulse combiner, the link integrity pulse to the gated signal to provide a processed received signal compatible with 10BASE-T Ethernet.

8. The method of claim 16, wherein at least one of 8A-8H:

15 8A) the first signal and the second signal are transmitted using on-off keyed modulation;

8B) the first signal and the second signal are optical signals;

20 8C) the first signal and the second signal are microwave radio frequency signals;

8D) wherein step 8C) further comprises:

8D1) providing, by a delay unit, a delay with a time duration corresponding to a predetermined mean propagation delay of a reflected signal to the receiver;

25 8D2) determining, by a packet envelope detector, a presence of the second signal; and

8D3) inverting, by an inverter gate, the presence of the second signal to produce the absence of the second signal;

8E) the control signal determiner is an AND gate;

30 8F) wherein step 8E) further comprises:

8F1) receiving, by an emitter driver, the transmitted signal and providing an emitter input and an absence determiner input; and

35 8F2) emitting the second signal over an azimuth angle of at least plus and minus 90 degrees;

8G) wherein step 8F) further comprises:

8G1) providing, by a timer, a 16 millisecond clock for a 100 nanosecond pulse generator based on the control signal; and

5 8G2) generating, by the 100 nanosecond pulse generator, the link integrity pulse; and

8H) wherein step 8A) further comprises:

8H1) allowing, by a detector, for a reception of at least a first signal, wherein the detector is capable of receiving at least the first signal over an azimuth angle of at least plus and minus 90 degrees; and

10 8H2) converting, by a receiver, at least the first signal into the received signal, wherein the received signal is an electrical signal;

15 and where further selected, at least one of 8H3-8H4:

8H3) wherein the detector is comprised of at least a first photodiode; and

8H4) wherein the detector is comprised of a Schottky barrier diode.

20

9. A system for providing wireless communication compatible with 10BASE-T Ethernet, wherein the wireless communication is between a communication unit and a 10BASE-T Ethernet network, the system comprising:

25

9A) a first transceiver, operably coupled to the communication unit, for receiving a first wireless signal to provide a first Ethernet signal and transmitting a second wireless signal based on a second Ethernet signal;

30

9B) a second transceiver, responsive to the second wireless signal of the first transceiver, for receiving the second wireless signal to provide a third Ethernet signal and transmitting the first wireless signal based on a fourth Ethernet signal; and

35

9C) an Ethernet bridge, operably coupled to the second transceiver, for communicating the third Ethernet signal and the fourth Ethernet signal with a 10BASE-T Ethernet network.

5

10. The system of claim 9, wherein one of 10A-10B:

10A) the communication unit is a portable computer; and

10B) the system further comprises a 10BASE-T Ethernet

card, operably coupled to the first transceiver, for converting

10

the first Ethernet signal to a communication unit input and converting a user input to the second Ethernet signal.

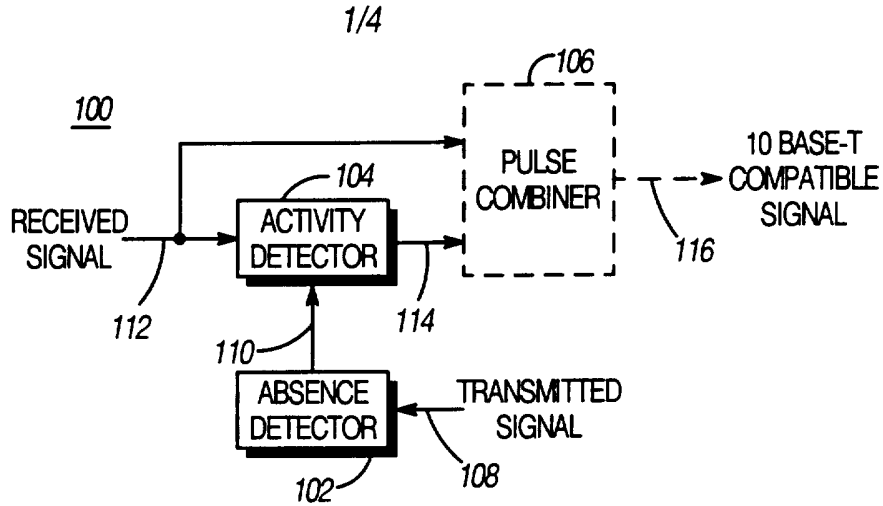

Fig.1

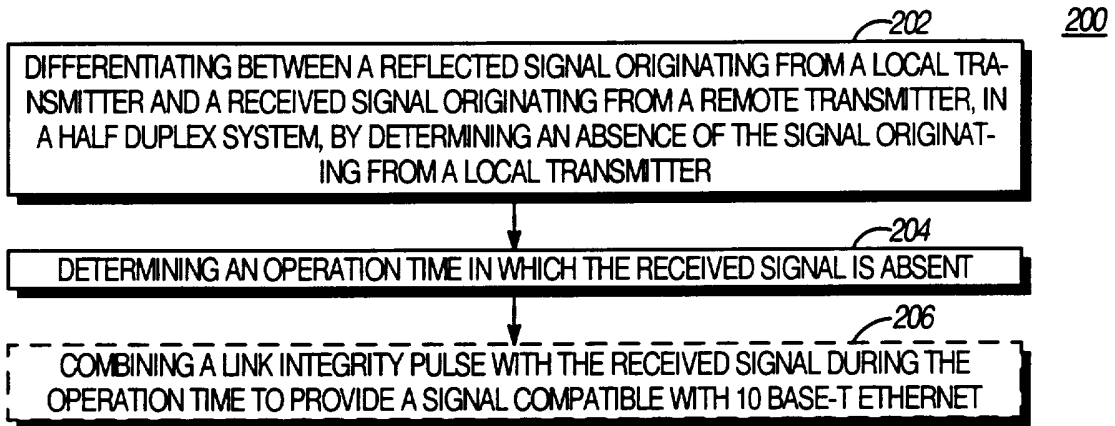

Fig.2

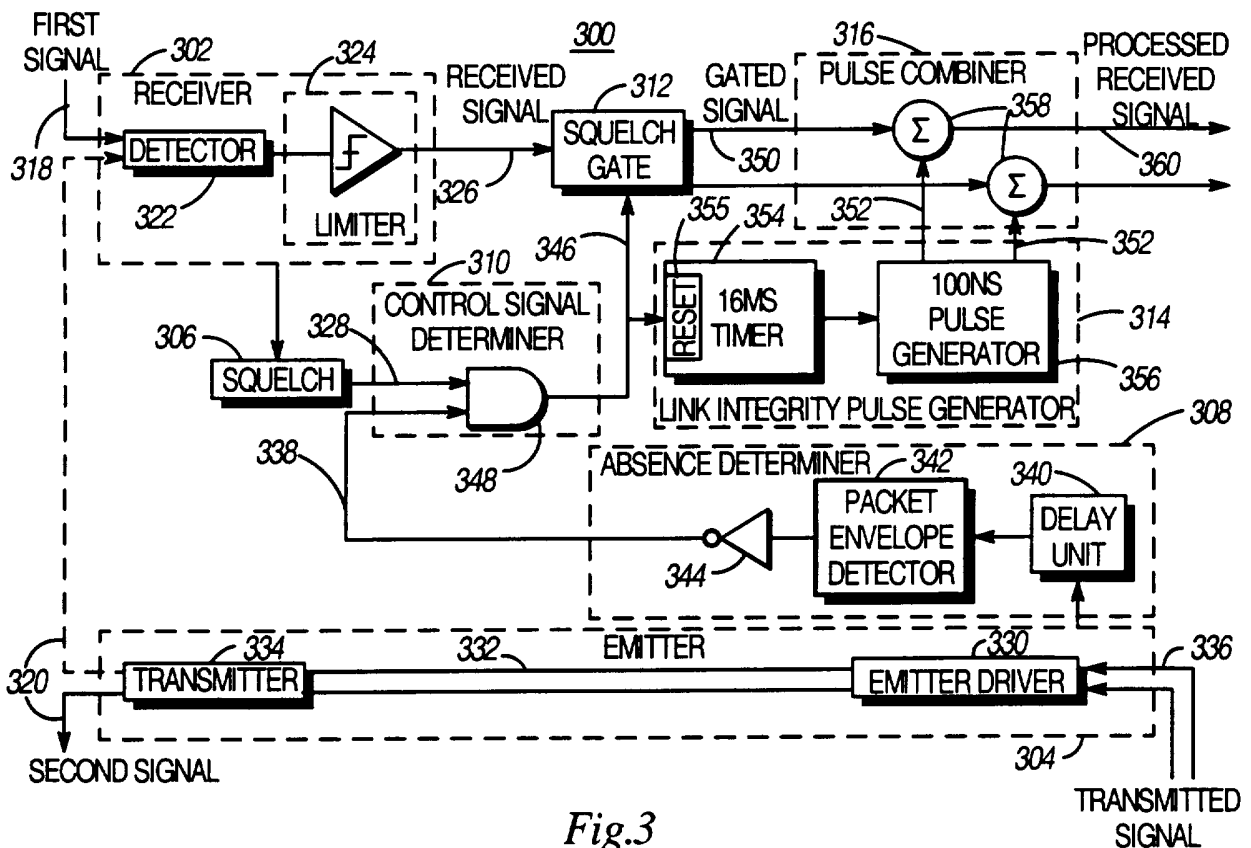

Fig.3

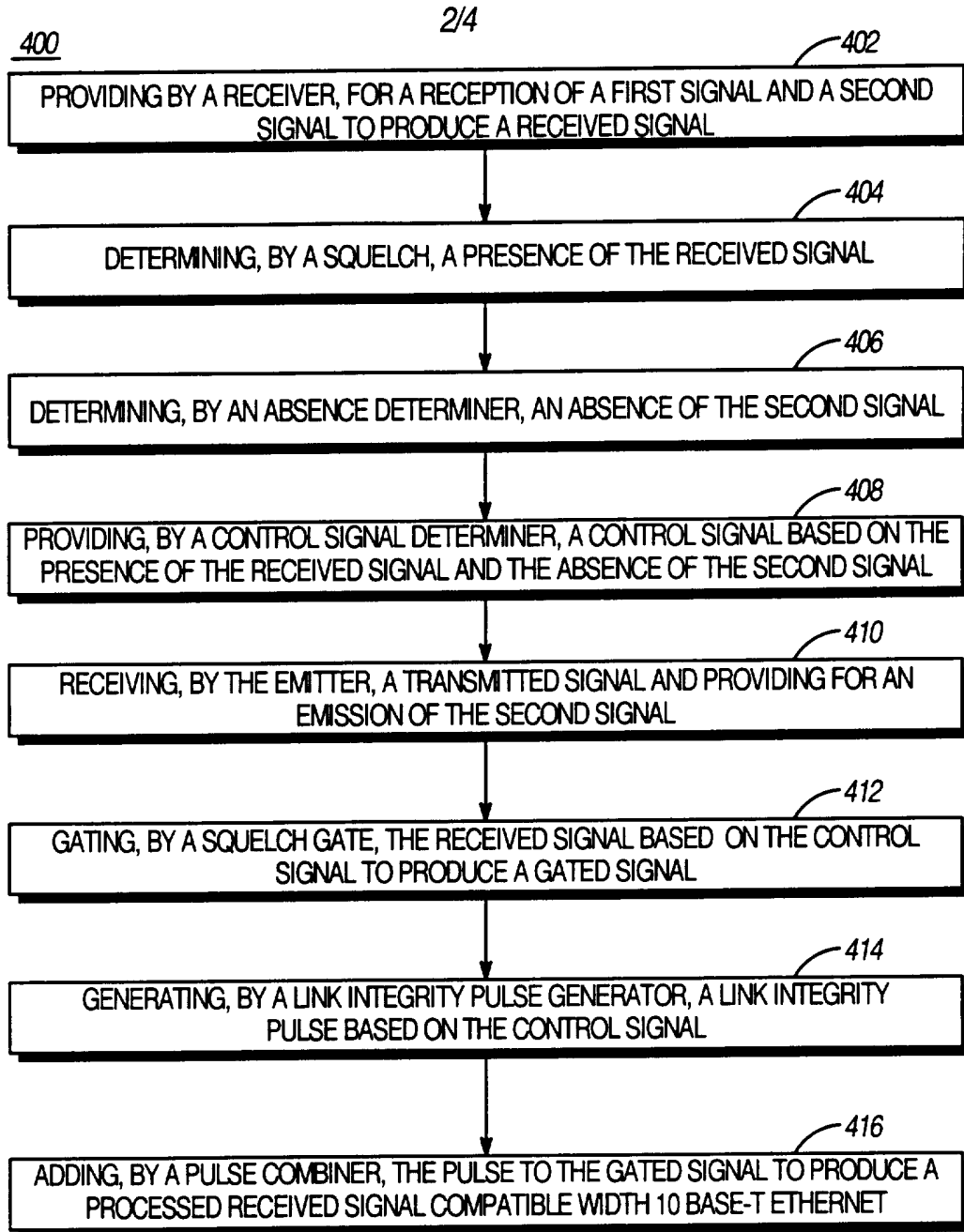

Fig.4

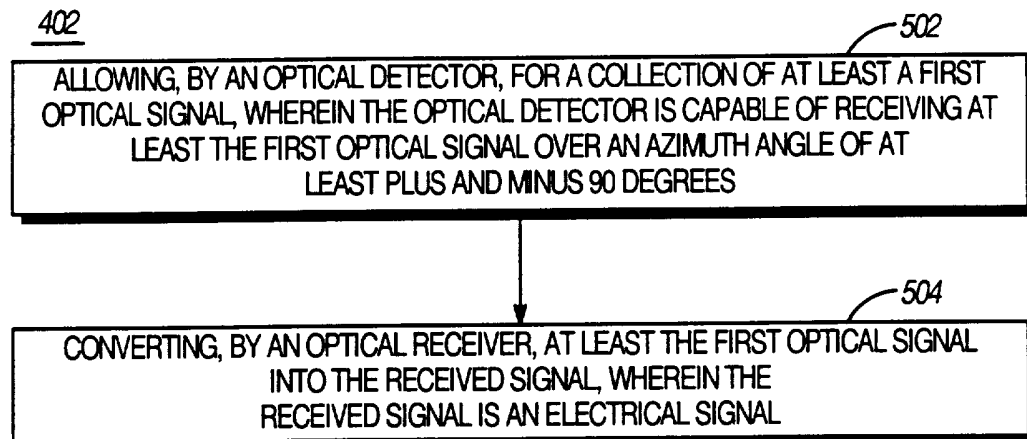

Fig.5

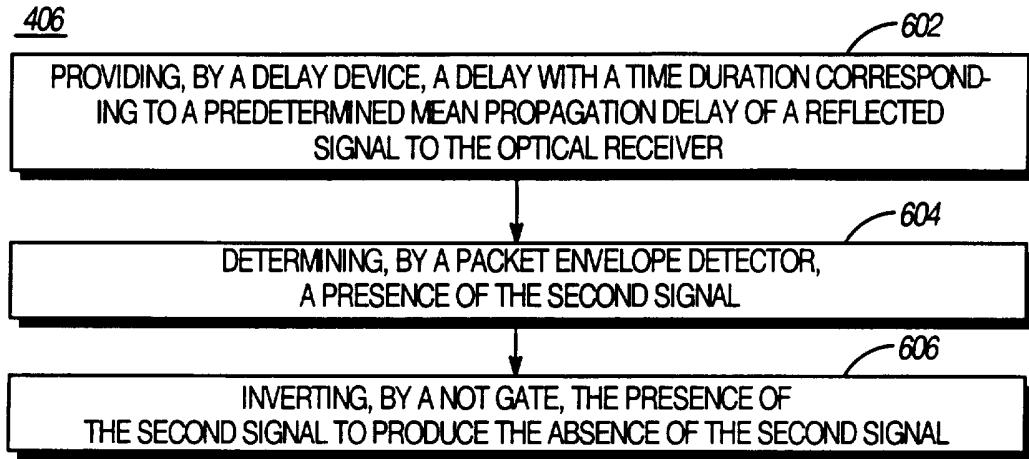

Fig.6

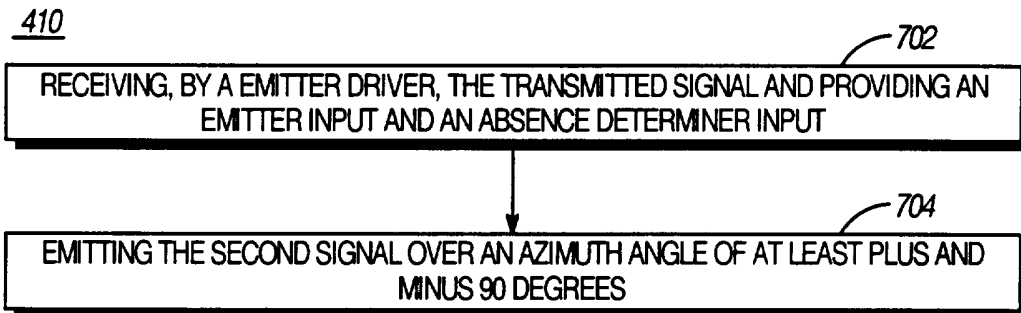

Fig.7

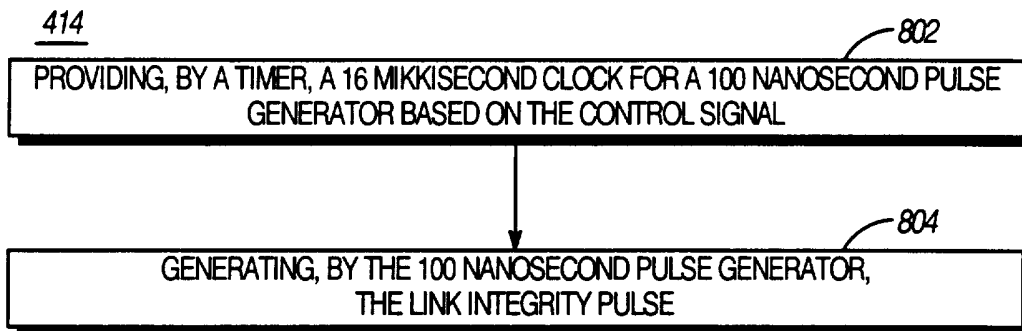

Fig.8

4/4

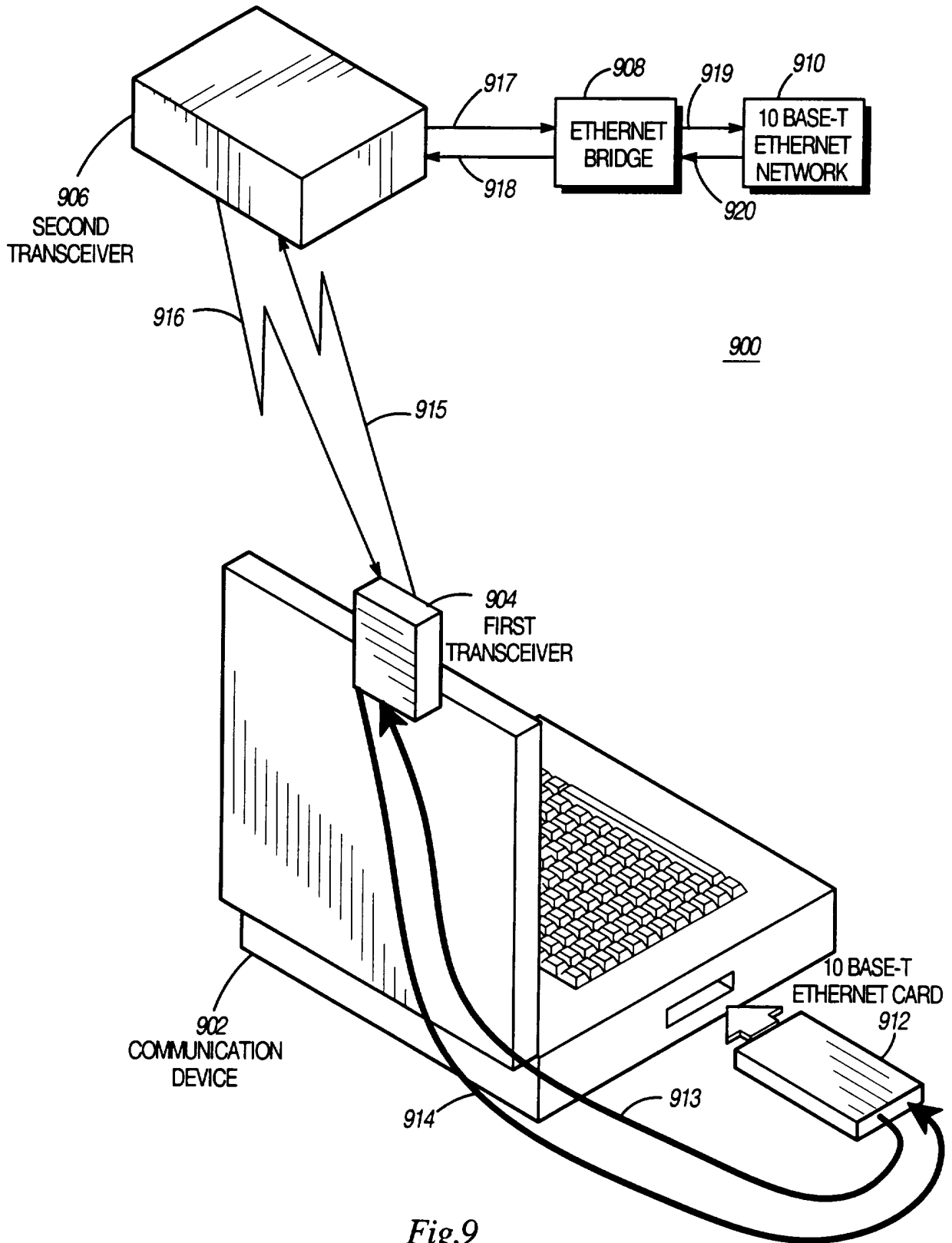

Fig.9

INTERNATIONAL SEARCH REPORT

International application No.
PCT/US95/13927

A. CLASSIFICATION OF SUBJECT MATTER

IPC(6) : Please See Extra Sheet.

US CL : 370/27, 31, 32, 32.1, 85.3; 340/825.36; 375/243; 359/189

According to International Patent Classification (IPC) or to both national classification and IPC

B. FIELDS SEARCHED

Minimum documentation searched (classification system followed by classification symbols)

U.S. : 370/27, 31, 32, 32.1, 85.3; 340/825.36; 375/243; 359/189

Documentation searched other than minimum documentation to the extent that such documents are included in the fields searched

Electronic data base consulted during the international search (name of data base and, where practicable, search terms used)

APS

search terms: Base-T, wireless, detector, transceiver

C. DOCUMENTS CONSIDERED TO BE RELEVANT

Category*	Citation of document, with indication, where appropriate, of the relevant passages	Relevant to claim No.
X	US, A, 5,319,363 (WELCH ET AL.) 07 JUNE 1994, col. 2, line 58 to col. 3, line 2, col. 5, lines 1-16, col. 6, lines 41-46, and Fig. 1.	27-29
Y,P	US, A, 5,434,775 (SIMS ET AL.) 18 JULY 1995, col. 22, lines 1-12, col. 8, lines 3-19, and col. 12, lines 14-35.	1-26
Y,P	US, A, 5,390,039 (YAMAMOTO ET AL.) 14 FEBRUARY 1995, col. 7, lines 8-32.	1-26
Y	US, A, 5,355,242 (EASTMOND ET AL.) 11 OCTOBER 1994, col. 3, lines 41-61 and Fig. 1.	2, 4-26

 Further documents are listed in the continuation of Box C.
 See patent family annex.

* Special categories of cited documents:	"T"	later document published after the international filing date or priority date and not in conflict with the application but cited to understand the principle or theory underlying the invention
"A" document defining the general state of the art which is not considered to be part of particular relevance	"X"	document of particular relevance; the claimed invention cannot be considered novel or cannot be considered to involve an inventive step when the document is taken alone
"E" earlier document published on or after the international filing date	"Y"	document of particular relevance; the claimed invention cannot be considered to involve an inventive step when the document is combined with one or more other such documents, such combination being obvious to a person skilled in the art
"L" document which may throw doubts on priority claim(s) or which is cited to establish the publication date of another citation or other special reason (as specified)	"&"	document member of the same patent family
"O" document referring to an oral disclosure, use, exhibition or other means		
"P" document published prior to the international filing date but later than the priority date claimed		

Date of the actual completion of the international search

25 JANUARY 1996

Date of mailing of the international search report

15 FEB 1996

Name and mailing address of the ISA/US
Commissioner of Patents and Trademarks
Box PCT
Washington, D.C. 20231

Facsimile No. (703) 305-3230

Authorized officer

DOUGLAS OLMS

Telephone No. (703) 305-4703

INTERNATIONAL SEARCH REPORT

International application No.
PCT/US95/13927

C (Continuation). DOCUMENTS CONSIDERED TO BE RELEVANT		
Category*	Citation of document, with indication, where appropriate, of the relevant passages	Relevant to claim No.
Y	US, A, 4,742,543 (FREDERIKSEN) 03 MAY 1988, col. 6, lines 19-47 and col. 18, line 55 to col. 19, line 11.	2, 4-26
A	US, A, 4,843,621 (POTRATZ) 27 JUNE 1989, see entire document.	1-27

INTERNATIONAL SEARCH REPORT

International application No.
PCT/US95/13927

A. CLASSIFICATION OF SUBJECT MATTER:

IPC (6):

G08B 5/22; G06F 15/00; H04B 1/52, 1/58, 3/20, 14/04, 10/06; H04J 1/00, 3/00, 15/00, 3/02