

Carley & Broughton,

Planing Wood.

No. 102219.

Patented Apr. 26. 1870.

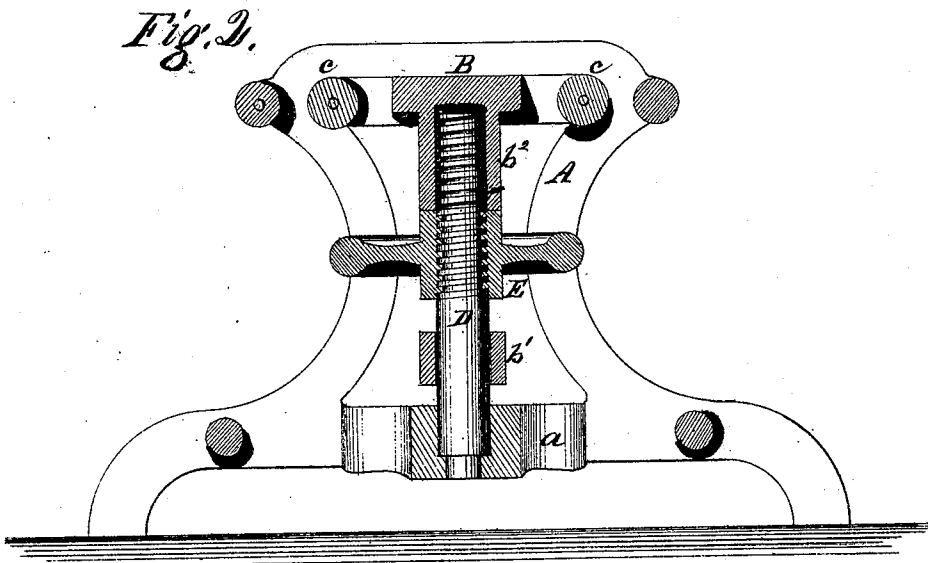
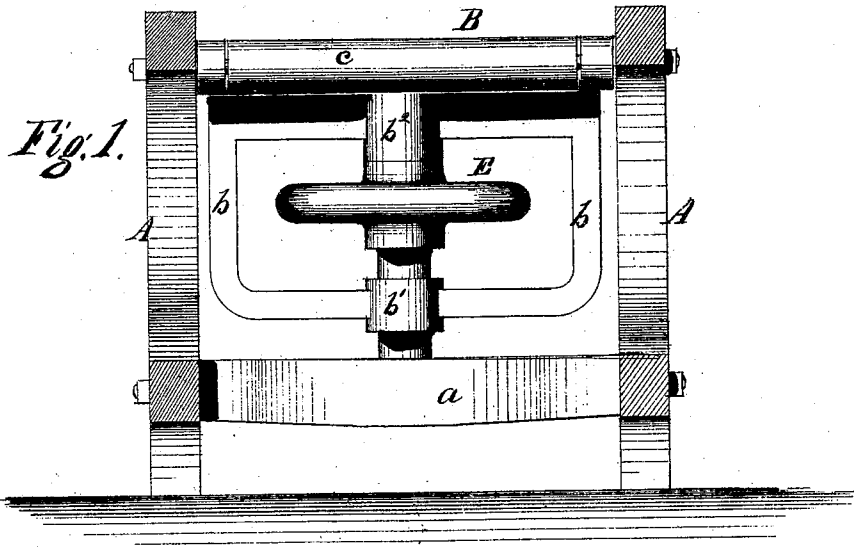

Witnesses.

Chas. Dodge
W. Nish

Inventors.

J. L. Carley
M. Broughton
per J. C. Morley & Co
Attys.

United States Patent Office.

TIMOTHY L. CARLEY AND MILTON BROUGHTON, OF HOMER, NEW YORK; SAID MILTON BROUGHTON ASSIGNS HIS RIGHT TO SAID CARLEY.

Letters Patent No. 102,219, dated April 26, 1870.

IMPROVEMENT IN PLANING-MACHINE.

The Schedule referred to in these Letters Patent and making part of the same.

To all whom it may concern:

Be it known that we, TIMOTHY L. CARLEY and MILTON BROUGHTON, of Homer, in the county of Cortland and State of New York, have invented a new and useful Improvement in Planing-Machines; and we do hereby declare that the following is a full, clear, and exact description thereof, which will enable those skilled in the art to make the same, reference being had to the accompanying drawings forming part of this specification, in which—

Figure 1 shows a vertical cross-section of the supporting-frame, with our improvement; and

Figure 2 is a vertical central longitudinal section of the same.

Similar letters of reference indicate like parts.

This improvement relates to a new construction and arrangement of the parts for raising and lowering the table or bed of wood-planers, whereby the adjustment of the bed is made more readily than by the ordinary methods, and a simple and substantial construction of the parts is obtained, as hereinafter more fully described.

In the accompanying drawings—

A A a is the frame-work, in which is mounted the vertically-adjustable table or bed B.

The bed B is raised and lowered by a single screw, D, placed under its center, the screw being fixed rigidly in the bottom piece a of the frame, and a hand-wheel nut, E, traveling on said screw, to carry the bed vertically.

The bed B has rollers c c, as ordinarily, and on its lower side is provided with a sleeve or collar, b², which travels on the upper part of the screw, and the table has also a yoke, b b, fig. 1, which reaches down below the nut E, and embraces the base or lower part of the screw by means of a collar, b¹; the said collars b¹ and b² acting as guides to steady the table in a vertical position within the frame A A.

By this construction the adjustment of the table or bed B is made with the greatest facility, and a strong and simple construction and arrangement of the parts are obtained.

We do not claim, broadly, the use of a single screw for raising and lowering the bed of a planing-machine, as that is not new; but having thus described our invention,

What we claim as new, and desire to secure by Letters Patent, is—

The screw D, rigidly secured in the framing A a, and carrying the bed B and hand-wheel nut E, said bed being provided with rollers c c, and with guides b b¹ b² fitted on the screw, all constructed, arranged, and operating substantially as described.

The above specification of our invention signed by us this 22d day of February, 1870

TIMOTHY L. CARLEY.
MILTON BROUGHTON.

Witnesses:

WM. J. DODGE,
F. A. MORLEY.