



US008969905B2

(12) **United States Patent**
Okabe et al.

(10) **Patent No.:** **US 8,969,905 B2**
(45) **Date of Patent:** **Mar. 3, 2015**

(54) **SEMICONDUCTOR LIGHT EMITTING DEVICE AND METHOD FOR MANUFACTURING SEMICONDUCTOR LIGHT EMITTING DEVICE, AND LAMP**

USPC 257/E33.055, E33.065, 98, 99; 438/42
See application file for complete search history.

(75) Inventors: **Takehiko Okabe**, Chiba (JP); **Daisuke Hiraiwa**, Ichihara (JP); **Remi Ohba**, Ichihara (JP)

(56) **References Cited**

U.S. PATENT DOCUMENTS

2005/0104080 A1* 5/2005 Ichihara et al. 257/98
2005/0277218 A1* 12/2005 Nakajo et al. 438/46

(73) Assignee: **Toyota Gosei Co., Ltd.**, Aichi (JP)

(Continued)

(*) Notice: Subject to any disclaimer, the term of this patent is extended or adjusted under 35 U.S.C. 154(b) by 233 days.

FOREIGN PATENT DOCUMENTS

JP 10-242516 A 9/1998
JP 10-242518 A 9/1998

(21) Appl. No.: **13/141,849**

(Continued)

(22) PCT Filed: **Dec. 15, 2009**

OTHER PUBLICATIONS

(86) PCT No.: **PCT/JP2009/006886**

Office Action with a mailing date of Dec. 25, 2012 for corresponding Taiwanese Application No. 098143668.

§ 371 (c)(1),
(2), (4) Date: **Jun. 23, 2011**

(Continued)

(87) PCT Pub. No.: **WO2010/073539**

Primary Examiner — Marc Armand

PCT Pub. Date: **Jul. 1, 2010**

Assistant Examiner — Sarah Salerno

(65) **Prior Publication Data**

US 2011/0255294 A1 Oct. 20, 2011

(74) *Attorney, Agent, or Firm* — Sughrue Mion, PLLC

(30) **Foreign Application Priority Data**

Dec. 25, 2008 (JP) 2008-329977

(57) **ABSTRACT**

(51) **Int. Cl.**

H01L 33/38 (2010.01)

H01L 33/40 (2010.01)

(Continued)

A semiconductor light-emitting device (1) of the present invention includes: a substrate (101); a laminated semiconductor layer (20) containing a light-emitting layer, which is formed on the substrate (101); a first electrode (111) formed on the upper surface (106c) of the laminated semiconductor layer (20); and a second electrode (108) formed on an exposed surface (104c) that is formed by partially cutting the laminated semiconductor layer (20), wherein the first electrode (111) includes a transparent electrode (109) containing a hole portion (109a) through which the upper surface (106c) of the laminated semiconductor layer (20) is exposed, a junction layer (110) formed on a bottom surface (109b) and an inner wall (109d) of the hole portion (109a), and a bonding pad electrode (120) formed to cover the junction layer (110).

(52) **U.S. Cl.**

CPC **H01L 33/405** (2013.01); **H01L 33/32** (2013.01); **H01L 33/42** (2013.01)

USPC **257/99**; 257/E33.066; 434/42

(58) **Field of Classification Search**

CPC H01L 33/42; H01L 33/405; H01L 33/387

14 Claims, 13 Drawing Sheets

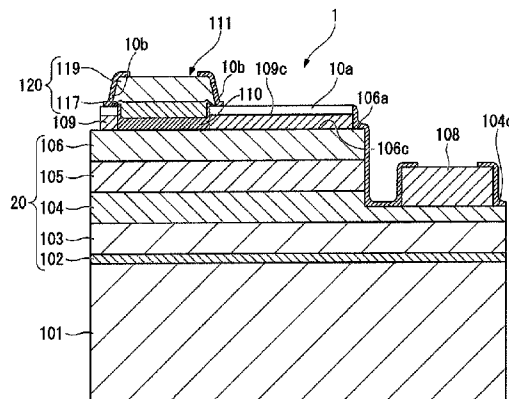

(51) **Int. Cl.**
H01L 33/32 (2010.01)
H01L 33/42 (2010.01)

JP 2004-186543 A 7/2004
 JP 2005-11857 A 1/2005
 JP 2005-045038 A 2/2005
 JP 2006-13034 A 1/2006
 JP 2006-66903 A 3/2006
 JP 2006-173506 A 6/2006
 JP 2008-034822 A 2/2008
 JP 2008-182050 A 8/2008
 JP 2008-192710 A 8/2008
 JP 2008-218440 A 9/2008

(56) **References Cited**

U.S. PATENT DOCUMENTS

2006/0124954 A1* 6/2006 Akaishi 257/99
 2007/0090378 A1* 4/2007 Lee et al. 257/94
 2008/0142821 A1* 6/2008 Sakamoto et al. 257/98
 2009/0001407 A1* 1/2009 Osawa et al. 257/99
 2009/0078951 A1* 3/2009 Miki et al. 257/98
 2010/0072487 A1* 3/2010 Tsai et al. 257/86

FOREIGN PATENT DOCUMENTS

JP 2803742 B2 9/1998
 JP 2003-101071 A 4/2003

OTHER PUBLICATIONS

Japanese Office Action (“Decision of Rejection”) with a mailing date of Sep. 3, 2013 for corresponding Japanese Patent Application No. 2008-329977.

* cited by examiner

FIG. 1

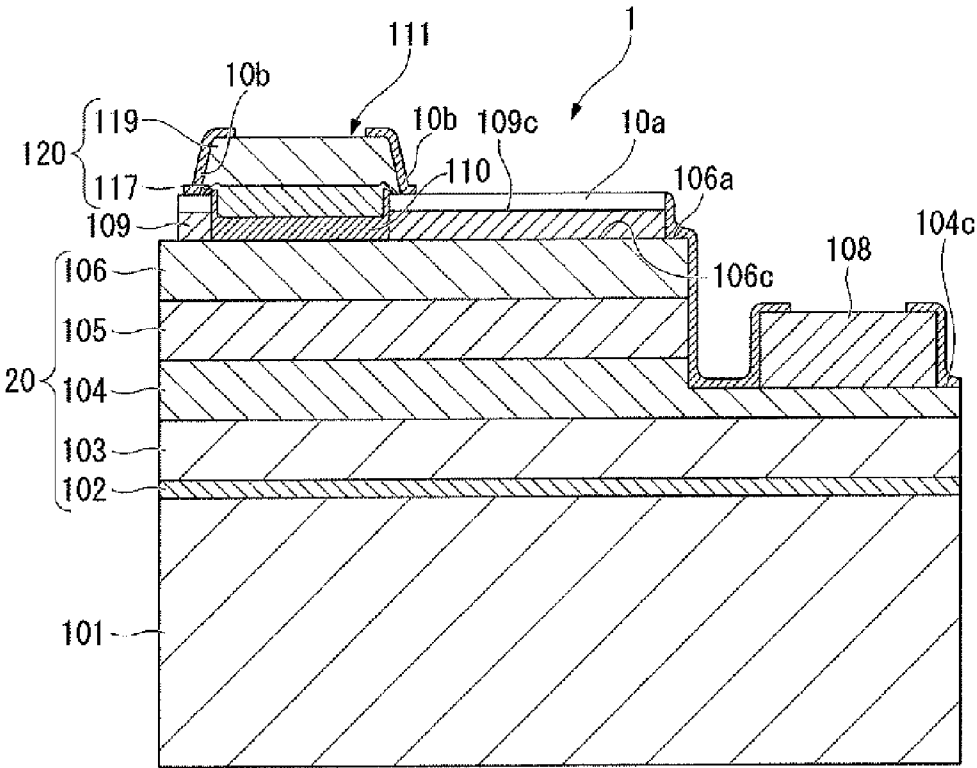

FIG. 2

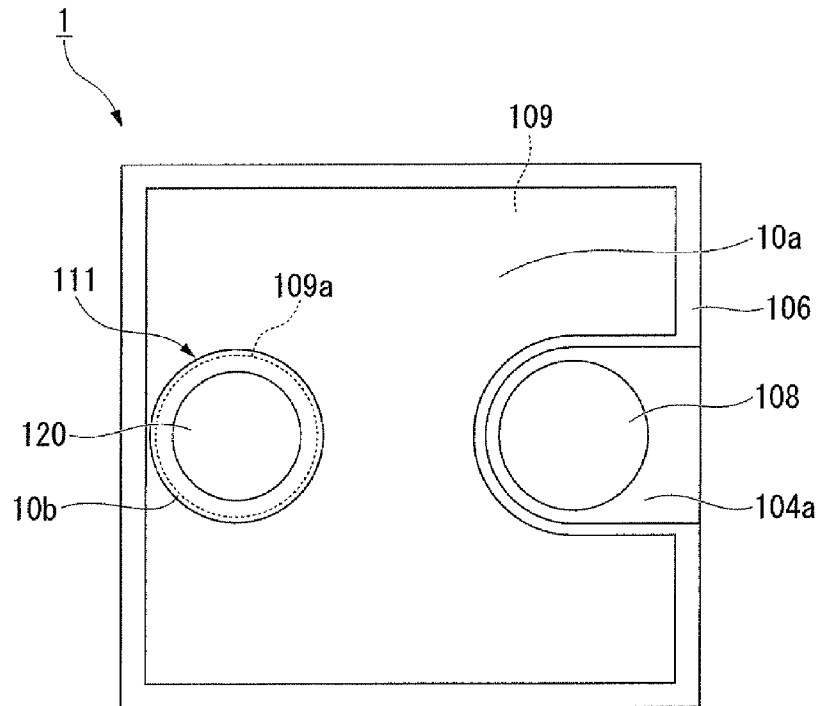

FIG. 3

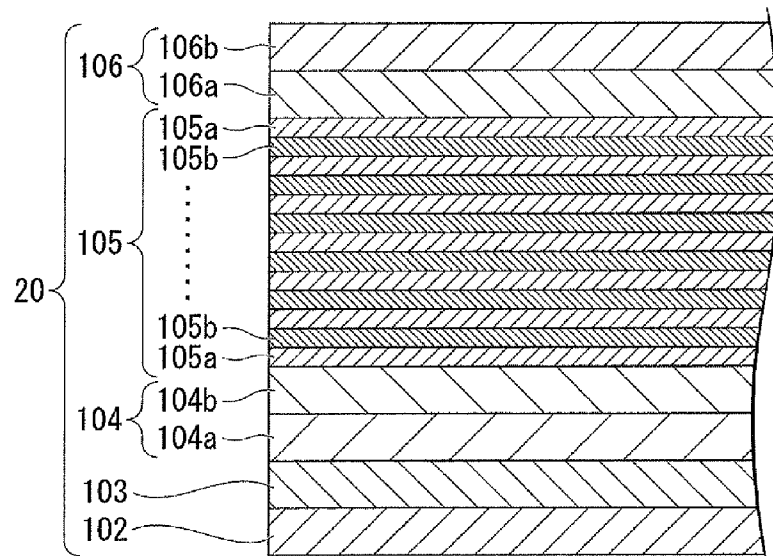

FIG. 4

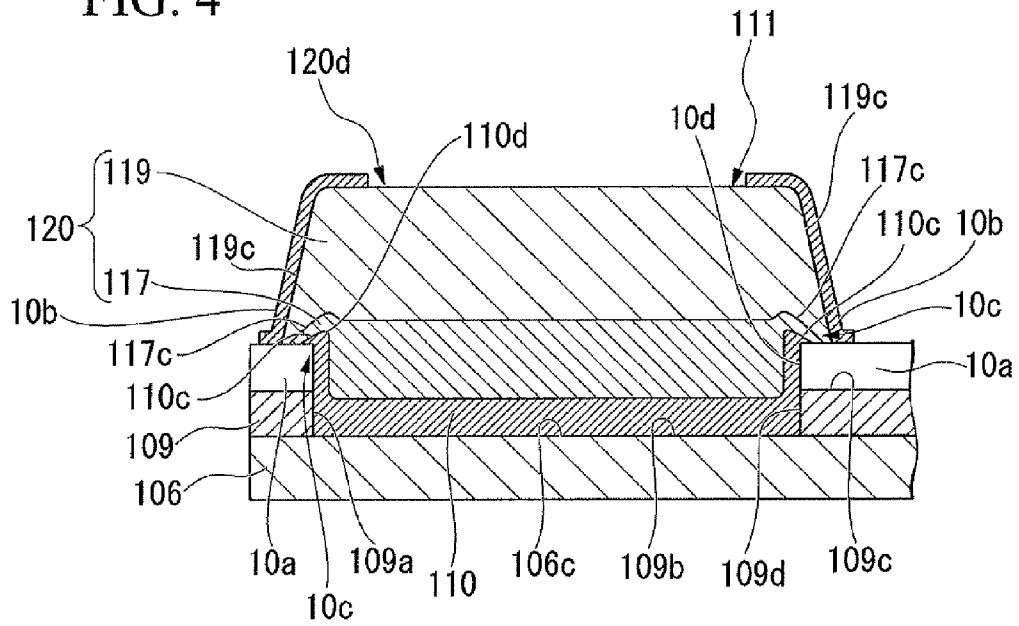

FIG. 5A

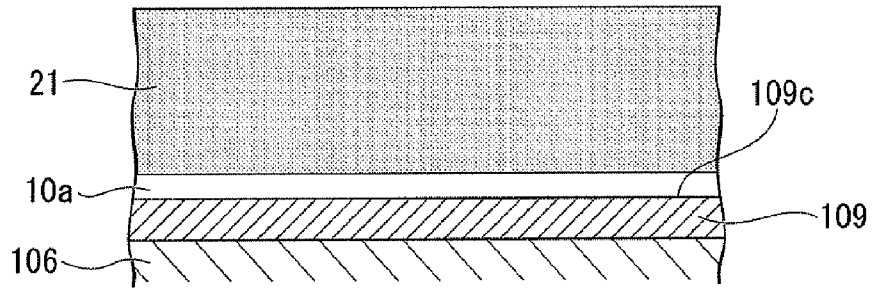

FIG. 5B

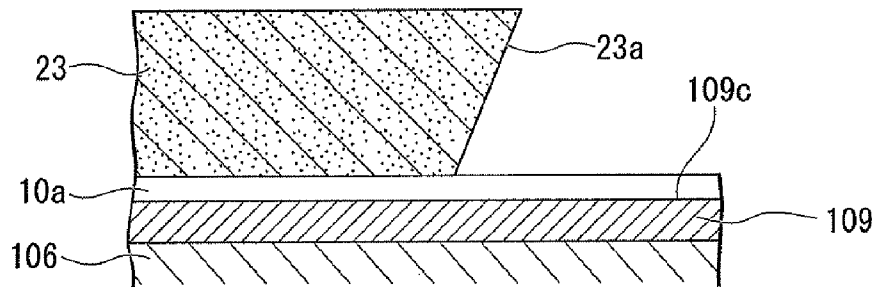

FIG. 5C

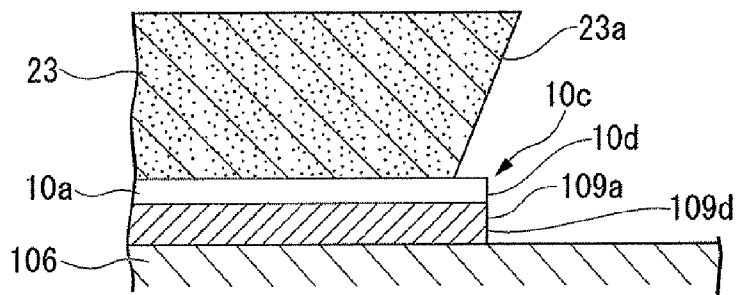

FIG. 5D

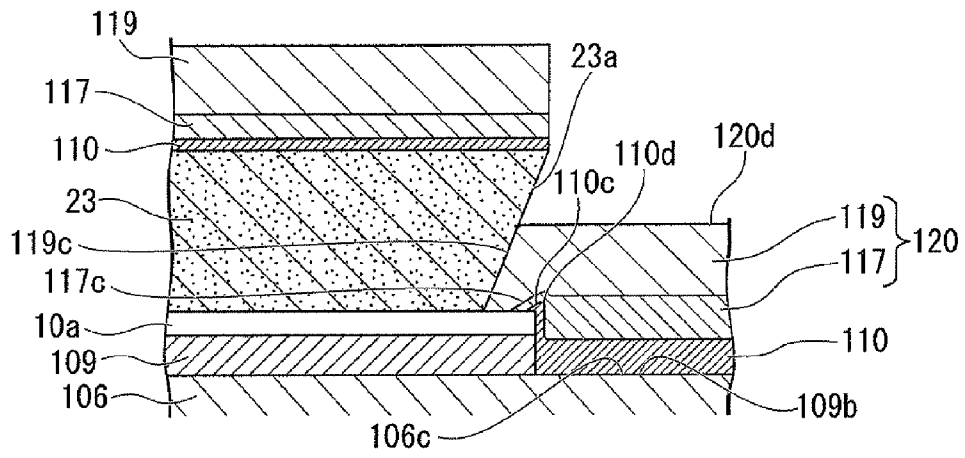

FIG. 5E

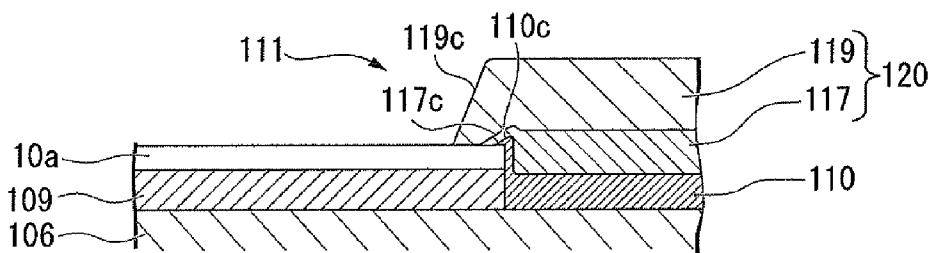

FIG. 6A

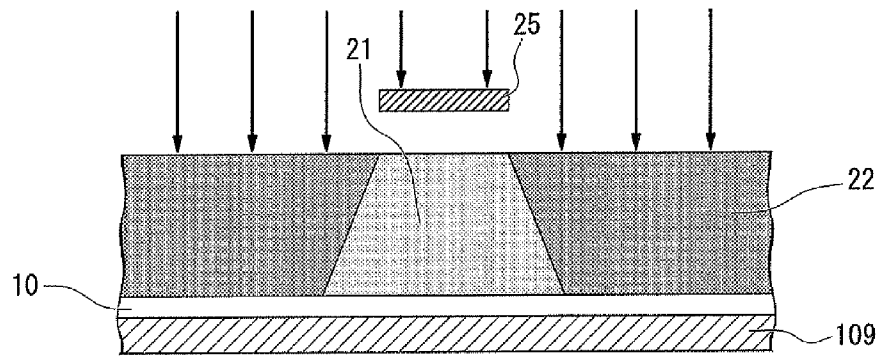

FIG. 6B

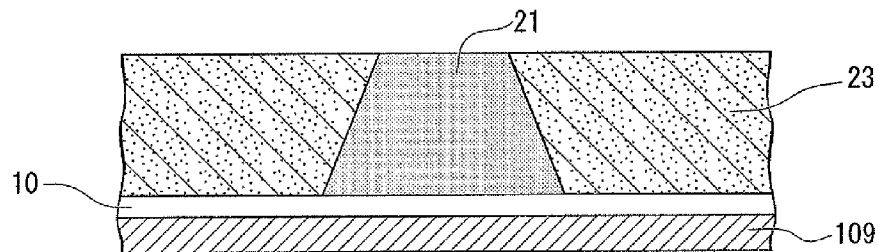

FIG. 6C

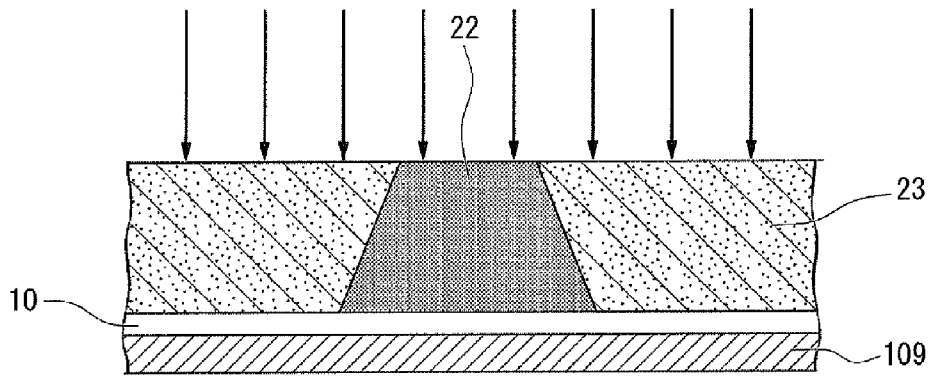

FIG. 6D

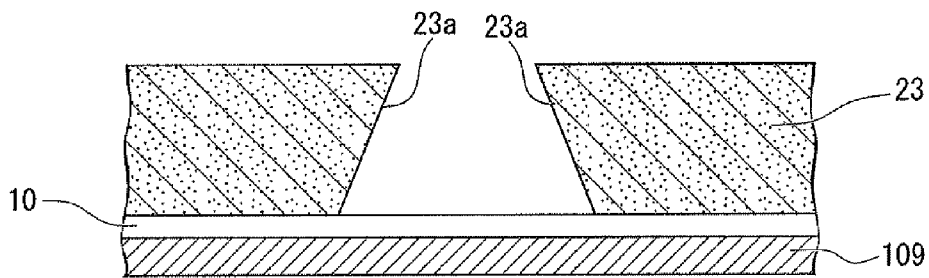

FIG. 7

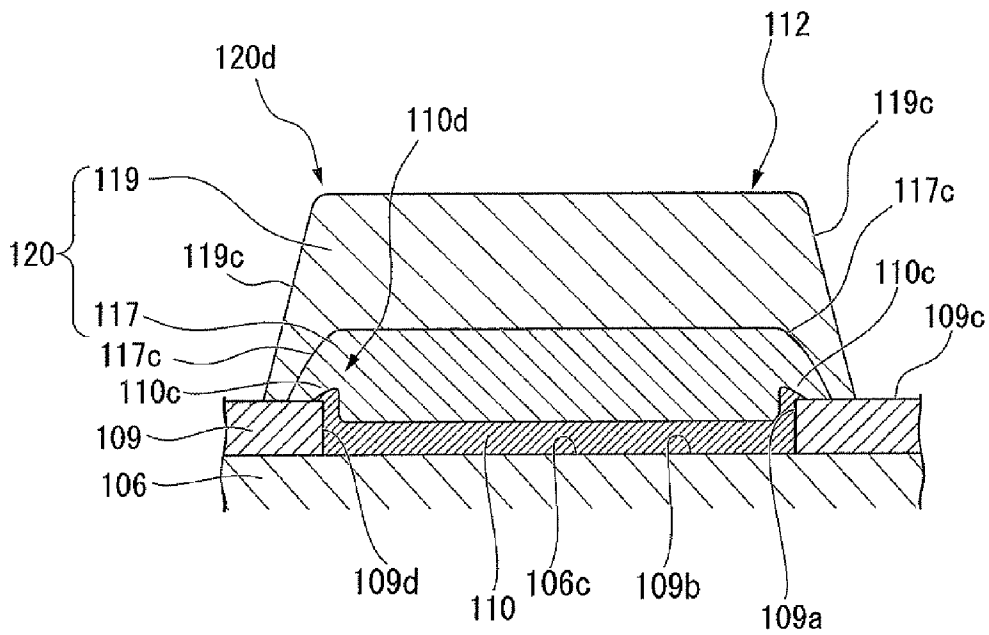

FIG. 8

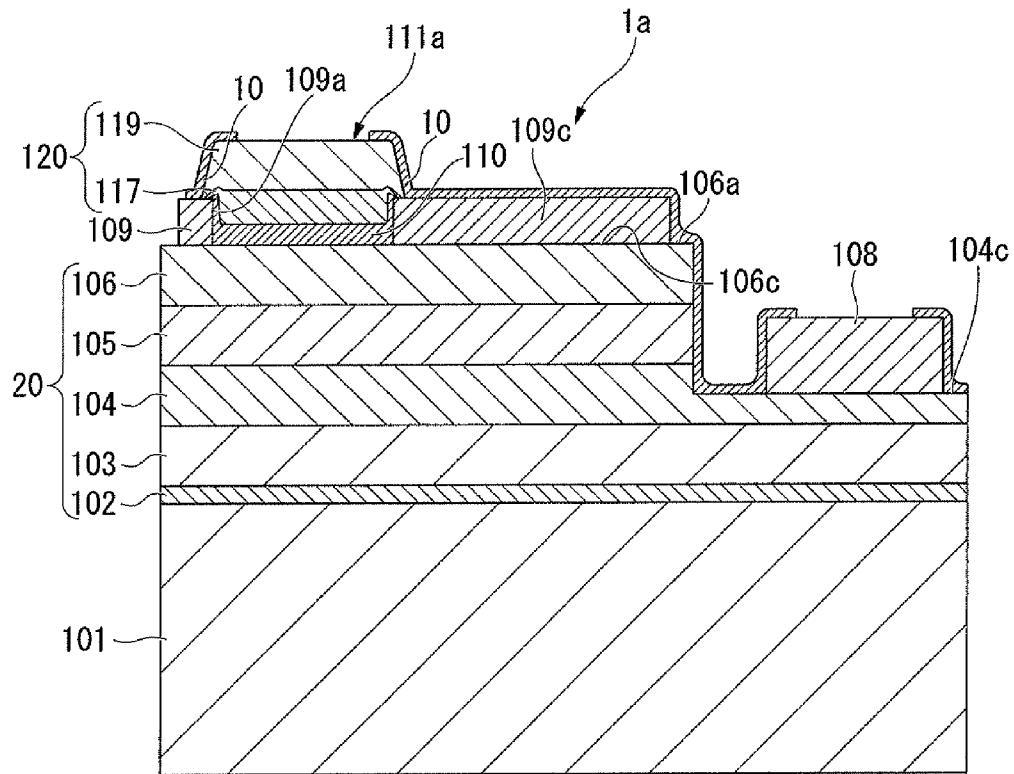

FIG. 9A

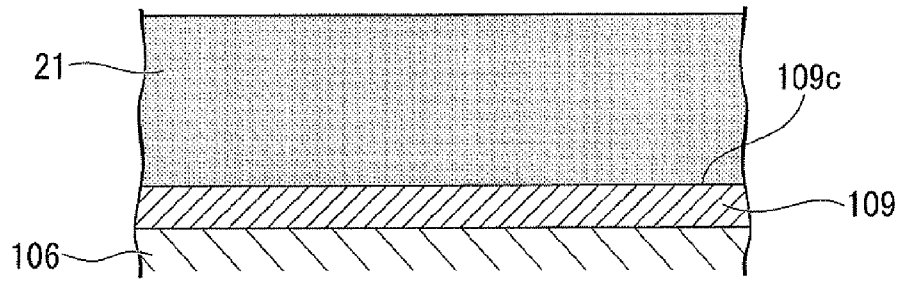

FIG. 9B

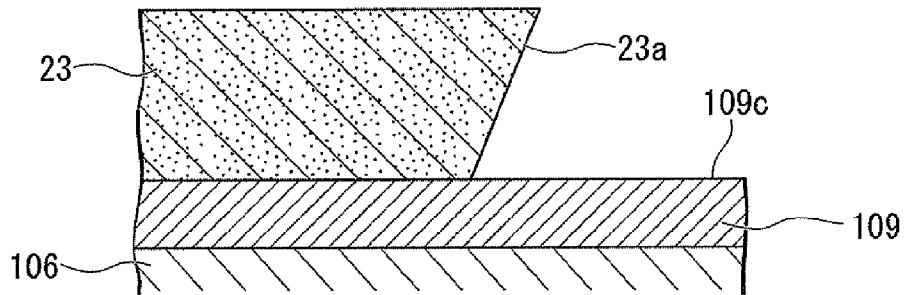

FIG. 9C

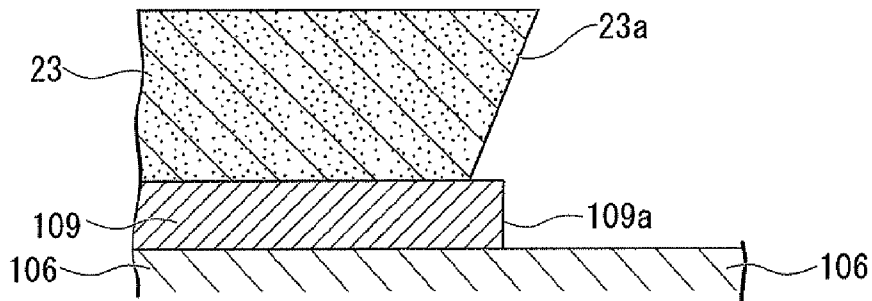

FIG. 9D

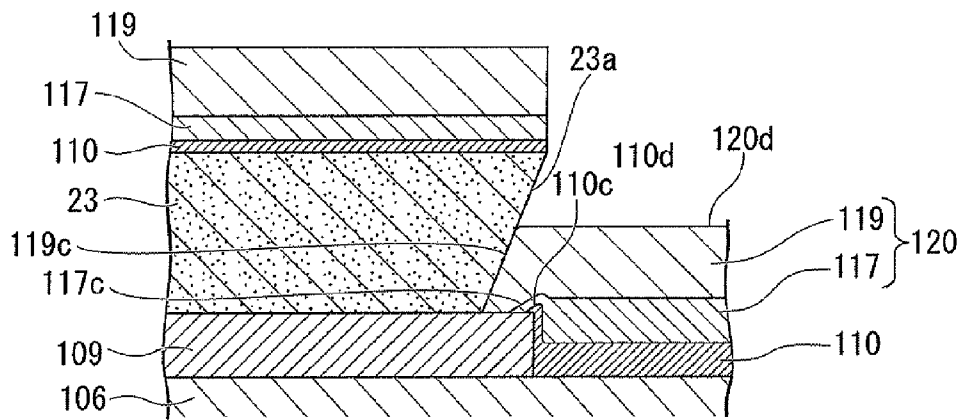

FIG. 9E

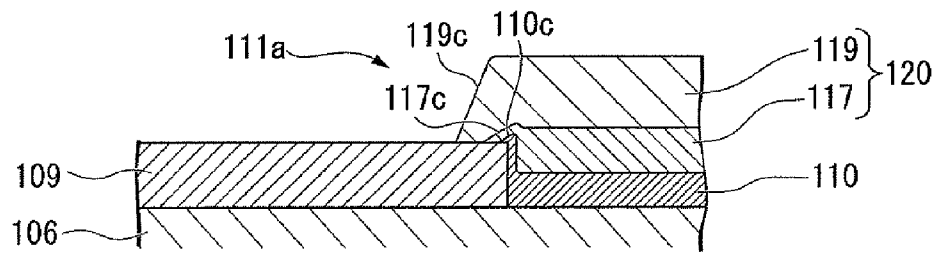

FIG. 10

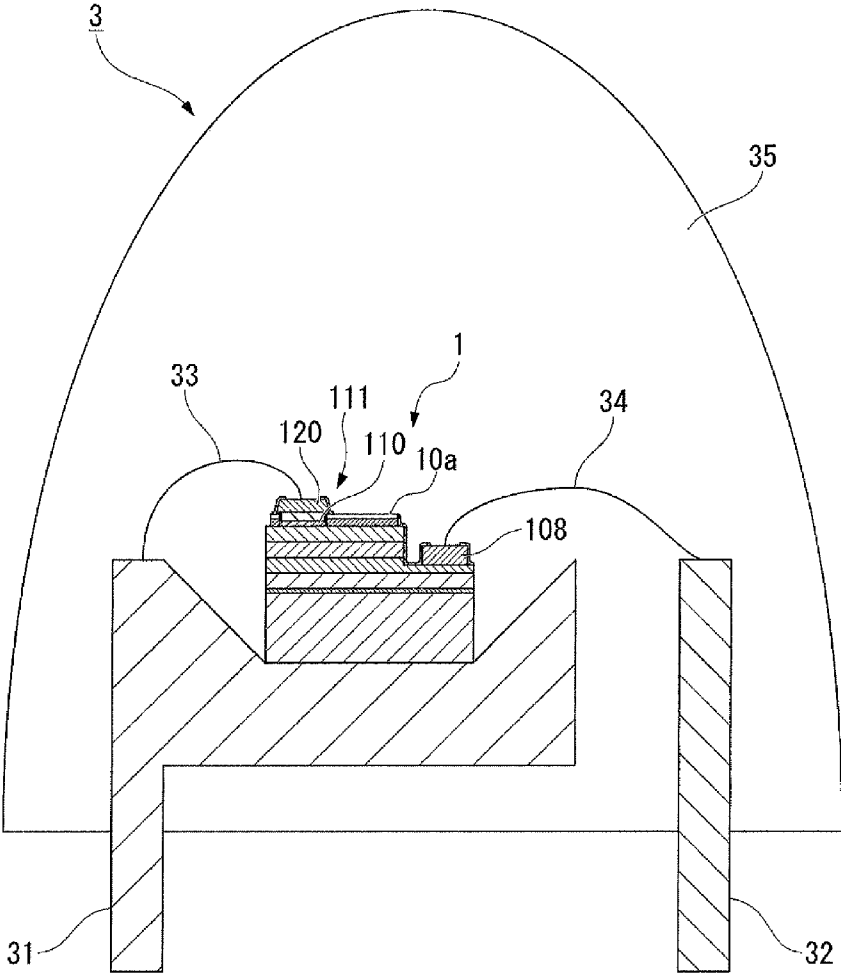
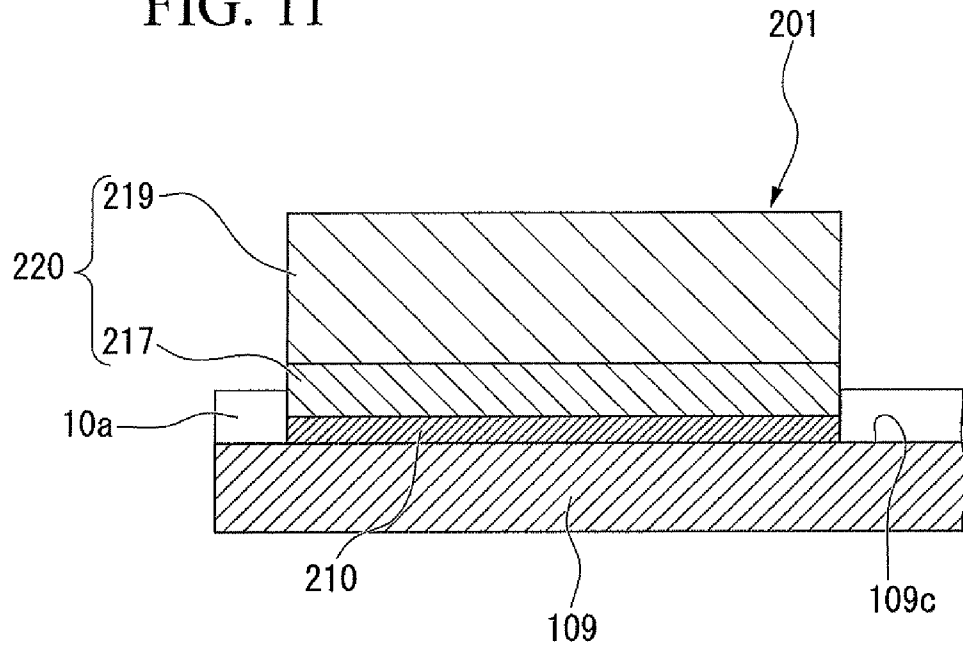

FIG. 11



**SEMICONDUCTOR LIGHT EMITTING
DEVICE AND METHOD FOR
MANUFACTURING SEMICONDUCTOR
LIGHT EMITTING DEVICE, AND LAMP**

TECHNICAL FIELD

The present invention relates to a semiconductor light-emitting device, a production method of the semiconductor light-emitting device, and a lamp, and more particularly to a semiconductor light-emitting device that is excellent in a junction property of an electrode and light extraction efficiency, a production method thereof, and a lamp equipped therewith.

Priority is claimed on Japanese Patent Application No. 2008-329977, filed in the Japan Patent Office on Dec. 25, 2008, and the content of which is incorporated herein by reference.

BACKGROUND ART

Recently, as a semiconductor material for a short-wavelength light-emitting device, a GaN-based compound semiconductor has received attention. Generally, a GaN-based compound semiconductor is formed on a substrate made of sapphire monocrystals, various oxides, or group III-V compounds by using a thin film-forming means such as a metalorganic chemical vapor deposition (MOCVD) method or a molecular beam epitaxy (MBE) method.

A thin film made of a GaN-based compound semiconductor has the characteristic of small current diffusion in an in-plane direction of the thin film. Further, a p-type GaN-based compound semiconductor has the characteristic of a high resistivity in comparison to an n-type GaN-based compound semiconductor. Due to this, in the case where only a p-type electrode made of metal is laminated on the surface of the p-type GaN-based compound semiconductor layer, there is almost no spread of current in the in-plane direction of the p-type semiconductor layer. Accordingly, for example, if a laminated semiconductor layer having an LED structure comprised of an n-type semiconductor layer, a light-emitting layer, and a p-type semiconductor layer is formed as a semiconductor light-emitting device using the GaN-based compound semiconductor, and also a p-type electrode is formed on the p-type semiconductor layer of an uppermost portion, then only a portion of the light-emitting layer that is positioned just below the p-type electrode emits light.

As a method of extracting the emitted light, which occurs just below the p-type electrode, out of the semiconductor light-emitting device, there is a method of using the transparent p-type electrode, transmitting the light occurring just below this p-type electrode through the p-type electrode, and extract the light out of the semiconductor light-emitting device. As the transparent p-type electrode, a method is known that uses a conductive metal oxide such as ITO or a metal thin film of about several tens of nanometers.

For example, Patent Literature 1 discloses a method that uses a metal thin film of about several tens of nanometers. However, the transparent electrode comprised of metal oxide such as ITO or the ohmic electrode comprised of a metal thin film of about several tens of nanometers has a problem of a low strength of the electrode itself.

In order to improve the strength of the electrode itself, there is the example in which a bonding pad electrode, which is made of a metal material and has a specified thickness, is arranged on a transparent electrode made of metal oxide such as ITO or a p-type electrode made of a metal thin film of about

several tens of nanometers. However, since this bonding pad electrode has no transparency and shields light, there was a problem in that it was not possible to extract light out of the semiconductor light-emitting device.

In order to solve this problem, for example, Patent Literature 2 discloses a method of laminating a bonding pad electrode formed of a reflection film, such as Ag, Al, on a p-type electrode. By forming the bonding pad electrode from the reflection film, it is possible that the emitted light that has transmitted the p-type electrode is reflected to the inside of the light-emitting device by the bonding pad electrode and the reflected light is extracted from a portion other than a bonding pad electrode forming area to the outside of the light-emitting device.

CITATION LIST

Patent Literature

- [Patent Literature 1]
Japanese Patent No. 2803742
[Patent Literature 2]
Japanese Unexamined Patent Application Publication No. 2006-66903

SUMMARY OF INVENTION

Technical Problem

However, when the bonding pad electrode made of the reflection film such as Ag, Al is provided on the transparent electrode made of the metal oxide such as ITO, there was the problem in that the bonding pad electrode was peeled off from the transparent electrode by the tensile stress during bonding of the bonding wire to the bonding pad electrode. Also, since the bonding pad electrode is peeled off from the transparent electrode, there was the problem in that the yield in manufacturing a lamp that uses such electrodes deteriorated.

The present invention has been made in view of the above-described problems, and an object of the invention is to provide a semiconductor light-emitting device that is excellent in a junction property, a production method thereof, and a lamp that is obtained by using the semiconductor light-emitting device, has good light extraction efficiency, and can be manufactured with good yield.

Solution to Problem

In order to achieve the above-described objects, the present invention adopts the following features.

- (1) A semiconductor light-emitting device comprising:
a substrate;
a laminated semiconductor layer containing a light-emitting layer, which is formed on the substrate;
a first electrode formed on the upper surface of the laminated semiconductor layer; and
a second electrode formed on an exposed surface that is formed by partially cutting the laminated semiconductor layer, wherein
the first electrode includes a transparent electrode containing a hole portion through which the upper surface of the laminated semiconductor layer is exposed, a junction layer formed on a bottom surface and an inner wall of the hole portion, and a bonding pad electrode formed to cover the junction layer.
(2) A semiconductor light-emitting device according to (1), wherein a junction resistivity between the laminated semi-

conductor layer and the junction layer is higher than a junction resistivity between the transparent electrode and the junction layer.

(3) The semiconductor light-emitting device according to (1) or (2), wherein the junction layer is made of at least one kind of element selected from the group consisting of Al, Ti, V, Cr, Mn, Co, Zn, Ge, Zr, Nb, Mo, Ru, Hf, Ta, W, Re, Rh, Ir, and Ni, and is a thin film whose maximum thickness is within a range from 10 Å or more to 400 Å or less.

(4) The semiconductor light-emitting device according to any one of (1) to (3), wherein the bonding pad electrode is comprised of a bonding layer made of Au, Al, or an alloy comprising any one of these metals.

(5) The semiconductor light-emitting device according to (4), wherein the bonding pad electrode is comprised of a metal reflection layer formed to cover the junction layer and the bonding layer formed to cover the metal reflection layer, and the metal reflection layer is made of any one selected from the group consisting of Ag, Al, Ru, Rh, Pd, Os, Ir, Pt, and Ti or an alloy comprising any one of these metals.

(6) The semiconductor light-emitting device according to (1) to (5), wherein the transparent electrode is made of a transparent conductive material selected from the group consisting of zinc sulfide, chromium sulfide, and a conductive oxide comprising any one kind selected from the group consisting of In, Zn, Al, Ga, Ti, Bi, Mg, W, Ce, Sn, and Ni.

(7) The semiconductor light-emitting device according to (1) to (6), wherein the laminated semiconductor layer is mainly comprised of a gallium nitride semiconductor.

(8) The semiconductor light-emitting device according to (1) to (7), wherein the laminated semiconductor layer is formed by laminating in order an n-type semiconductor layer, the light-emitting layer, and a p-type semiconductor layer on the substrate, and the light-emitting layer has a multiple quantum well structure.

(9) A lamp comprising:

the semiconductor light-emitting device according to any one of (1) to (8);

a first frame on which the semiconductor light-emitting device is arranged and which is wire-bonded with the first electrode of the semiconductor light-emitting device;

a second frame which is wire-bonded with the second electrode of the semiconductor light-emitting device; and a mold formed around the semiconductor light-emitting device.

(10) A method of manufacturing a semiconductor light-emitting device which comprises a substrate; a laminated semiconductor layer containing a light-emitting layer, which is formed on the substrate; a first electrode formed on the upper surface of the laminated semiconductor layer; and a second electrode formed on an exposed surface that is formed by partially cutting the laminated semiconductor layer,

the method comprising a first electrode manufacturing step which comprises the steps of:

forming a transparent electrode on the upper surface of the laminated semiconductor layer;

forming a hole portion of the transparent electrode, through which the upper surface of the laminated semiconductor layer is exposed;

forming a junction layer on a bottom surface and an inner wall of the hole portion; and

forming a bonding pad electrode to cover the junction layer.

(11) An electronic appliance incorporated with the lamp according to (9).

(12) A mechanical device incorporated with the electronic appliance according to (11).

Advantageous Effects of Invention

In a semiconductor light-emitting device of the present invention that is formed to incorporate the junction layer in the hole portion of the transparent electrode, it is possible to obtain high junction strength between the junction layer, and the transparent electrode and the laminated semiconductor layer. In addition, since the bonding pad electrode is formed to cover the junction layer, it is possible to obtain high junction strength between the junction layer and the bonding pad electrode. Therefore, it is possible to obtain high junction strength between the bonding pad electrode, and the transparent electrode and the laminated semiconductor layer. Also, it is possible to obtain a semiconductor light-emitting device that has the first electrode with a good junction property.

Also, a lamp according to the present invention is provided with a semiconductor light-emitting device according to the present invention which includes electrodes excellent in a junction property, and therefore, it can be manufactured with good yield.

Also, in a production method of a semiconductor light-emitting device of the present invention, a first electrode formation step comprises the steps of: forming a transparent electrode on the upper surface of the laminated semiconductor layer; forming a hole portion of the transparent electrode, through which the upper surface of the laminated semiconductor layer is exposed; forming a junction layer on a bottom surface and an inner wall of the hole portion; and forming a bonding pad electrode to cover the junction layer. Therefore, it is possible to easily produce a semiconductor light-emitting device of the present invention which has the first electrode with a good junction property.

BRIEF DESCRIPTION OF DRAWINGS

FIG. 1 is a view illustrating an example of a semiconductor light-emitting device of the present invention, and a schematic cross-sectional view of a semiconductor light-emitting device.

FIG. 2 is a schematic plan view of a semiconductor light-emitting device illustrated in FIG. 1.

FIG. 3 is an enlarged schematic cross-sectional view of a laminated semiconductor layer constituting a semiconductor light-emitting device illustrated in FIG. 1.

FIG. 4 is a schematic enlarged cross-sectional view of a p-type electrode constituting a semiconductor light-emitting device illustrated in FIG. 1.

FIG. 5A is a view illustrating an example of a step of manufacturing a p-type electrode, and an enlarged cross-sectional view illustrating only a portion of an area in which a p-type electrode is manufactured.

FIG. 5B is a view illustrating an example of a step of manufacturing a p-type electrode, and an enlarged cross-sectional view illustrating only a portion of an area in which a p-type electrode is manufactured.

FIG. 5C is a view illustrating an example of a step of manufacturing a p-type electrode, and an enlarged cross-sectional view illustrating only a portion of an area in which a p-type electrode is manufactured.

FIG. 5D is a view illustrating an example of a step of manufacturing a p-type electrode, and an enlarged cross-sectional view illustrating only a portion of an area in which a p-type electrode is manufactured.

5

FIG. 5E is a view illustrating an example of a step of manufacturing a p-type electrode, and an enlarged cross-sectional view illustrating only a portion of an area in which a p-type electrode is manufactured.

FIG. 6A is a view illustrating a step of manufacturing a mask illustrated in FIG. 5B, and an enlarged cross-sectional view illustrating only a portion of an area in which a p-type electrode is manufactured.

FIG. 6B is a view illustrating a step of manufacturing a mask illustrated in FIG. 5B, and an enlarged cross-sectional view illustrating only a portion of an area in which a p-type electrode is manufactured.

FIG. 6C is a view illustrating a step of manufacturing a mask illustrated in FIG. 5B, and an enlarged cross-sectional view illustrating only a portion of an area in which a p-type electrode is manufactured.

FIG. 6D is a view illustrating a step of manufacturing a mask illustrated in FIG. 5B, and an enlarged cross-sectional view illustrating only a portion of an area in which a p-type electrode is manufactured.

FIG. 7 is a view illustrating another example of a semiconductor light-emitting device according to the present invention, and a schematic enlarged cross-sectional view of a p-type electrode constituting the semiconductor light-emitting device.

FIG. 8 is a view illustrating another example of a semiconductor light-emitting device according to the present invention, and a schematic cross-sectional view of the semiconductor light-emitting device.

FIG. 9A is a view illustrating a step of manufacturing a p-type electrode, and an enlarged cross-sectional view illustrating only a portion of an area in which the p-type electrode is manufactured.

FIG. 9B is a view illustrating a step of manufacturing a p-type electrode, and an enlarged cross-sectional view illustrating only a portion of an area in which the p-type electrode is manufactured.

FIG. 9C is a view illustrating a step of manufacturing a p-type electrode, and an enlarged cross-sectional view illustrating only a portion of an area in which the p-type electrode is manufactured.

FIG. 9D is a view illustrating a step of manufacturing a p-type electrode, and an enlarged cross-sectional view illustrating only a portion of an area in which the p-type electrode is manufactured.

FIG. 9E is a view illustrating a step of manufacturing a p-type electrode, and an enlarged cross-sectional view illustrating only a portion of an area in which the p-type electrode is manufactured.

FIG. 10 is a schematic cross-sectional view illustrating an example of a lamp of the present invention.

FIG. 11 is a view illustrating effects of a semiconductor light-emitting device of the present invention, and a schematic enlarged cross-sectional view of a p-type electrode.

DESCRIPTION OF EMBODIMENTS

Hereinafter, the present invention will be described in detail using the accompanying drawings. In the following description of the present invention, the size, thickness, and dimensions of each portion as illustrated in the drawings referred to may be different from the actual relationship of the measurements of the semiconductor light-emitting device and the like.

Embodiment 1 Semiconductor Light-Emitting Device

FIG. 1 to FIG. 4 are views illustrating an example of a semiconductor light-emitting device of the present invention.

6

FIG. 1 is a schematic cross-sectional view illustrating an example of a semiconductor light-emitting device. FIG. 2 is a schematic plan view of a semiconductor light-emitting device illustrated in FIG. 1. FIG. 3 is an enlarged schematic cross-sectional view of a laminated semiconductor layer constituting a semiconductor light-emitting device illustrated in FIG. 1. FIG. 4 is a schematic enlarged cross-sectional view of a p-type electrode constituting a semiconductor light-emitting device illustrated in FIG. 1.

As shown in FIG. 1, a semiconductor light-emitting device 1 of the present embodiment includes: a substrate 101; a laminated semiconductor layer 20 which is formed on the substrate 101; a p-type electrode 111 (a first electrode) formed on the upper surface 106c of the laminated semiconductor layer 20; and a n-type electrode 108 (a second electrode) formed on an exposed surface 104c that is formed by partially cutting the laminated semiconductor layer 20.

As shown in FIG. 1, the laminated semiconductor layer 20 is formed by laminating in order the n-type semiconductor layer 104, the light-emitting layer 105, and the p-type semiconductor layer 106 on the substrate 101. The semiconductor light-emitting device 1 of the present embodiment is configured to obtain light emitted from the light-emitting layer 105 by applying a voltage and flowing a current between the p-type electrode 111 and the n-type electrode 108. Also, the semiconductor light-emitting device 1 of the present embodiment is a face up mount type light-emitting device which is configured to extract the light from the side where the p-type electrode 111 is formed.

<Substrate>

The substrate 101 may be selected and used from various kinds of substrates, without being specially limited, if the substrate 101 is a substrate on which a group III nitride semiconductor crystal is epitaxially grown onto the surface. For example, a substrate may be used, which is made of sapphire, SiC, silicon, zinc oxide, magnesium oxide, manganese oxide, zirconium oxide, manganese zinc iron oxide, magnesium aluminum oxide, zirconium boride, gallium oxide, indium oxide, lithium gallium oxide, lithium aluminum oxide, neodymium gallium oxide, lanthanum strontium aluminum tantalum oxide, strontium titanium oxide, titanium oxide, hafnium, tungsten, molybdenum, and the like. Also, particularly, it is preferable to use a sapphire substrate having a c-surface as its main surface among the above-described substrates.

Note that, among the above-described substrates, it is preferable to use an oxide substrate or a metal substrate, etc. which is chemically modified through contact with ammonia at high temperature because the buffer layer 102 can be formed without using ammonia.

<Laminated Semiconductor Layer>

The laminated semiconductor layer 20 of the semiconductor light-emitting device 1 according to the present embodiment is made of a group III nitride semiconductor, and as illustrated in FIG. 1, the buffer layer 102, the ground layer 103, the n-type semiconductor layer 104, the light-emitting layer 105, and the p-type semiconductor layer 106 are laminated on the substrate 101 in order. As illustrated in FIG. 3, each layer of the n-type semiconductor layer 104, the light-emitting layer 105, and the p-type semiconductor layer 106 may be formed as a plurality of semiconductor layers.

<Buffer Layer>

The buffer layer 102 functions to make it easy to form the C-axis oriented monocrystal layer on the (0001) C-surface of the substrate 101 by mitigating the difference in lattice constant between the substrate 101 and the ground layer 103. In

the present invention, it is preferable to form a buffer layer **102**, but such a buffer layer **102** may not be formed.

The thickness of the buffer layer **102**, for example, may be within a range from 0.01 to 0.5 μm . If the thickness of the buffer layer **102** is less than 0.01 μm , an effect of mitigating a difference in lattice constant between the substrate **101** and the ground layer **103** may not be sufficiently obtained by the buffer layer **102**. Also, if the thickness of the buffer layer **102** exceeds 0.5 μm , even if functioning as the buffer layer **102** is not changed, the time for the step of forming the buffer layer **102** is lengthened, thus deteriorating the productivity.

The buffer layer **102** is made of a group III nitride semiconductor and is preferably made of polycrystal $\text{Al}_x\text{Ga}_{1-x}\text{N}$ ($0 \leq x \leq 1$) or monocrystal $\text{Al}_x\text{Ga}_{1-x}\text{N}$ ($0 \leq x \leq 1$). The crystal of the group III nitride semiconductor that forms the buffer layer **102** may have a polycrystal structure or a monocrystal structure. Since the crystal of the group III nitride semiconductor controls the growth condition, it grows not only in an upward direction but also in an in-plane direction to form the monocrystal structure. Accordingly, by controlling the film-forming condition of the buffer layer **102**, the buffer layer **102** is made of the crystal of the group III nitride semiconductor of the monocrystal structure. When the buffer layer **102** having the monocrystal structure as described above is formed on the substrate **101**, the buffer function of the buffer layer **102** is effectively performed, and thus the group III nitride semiconductor formed thereon becomes a crystal layer having good orientation and crystallinity.

Also, the buffer layer **102** may have a crystal structure of a hexagonal crystal system that is made of a group III nitride semiconductor. Also, by controlling the film-forming condition, the crystal of the group III nitride semiconductor that forms the buffer layer **102** may become a column type crystal (polycrystal) comprised of a texture based on a hexagonal prism. Here, the column type crystal comprised of the texture means a crystal in which grain boundaries are formed between neighboring grains separated from each other and which is itself a column type that has a vertical profile.

Although the buffer layer **102** may be formed by a MOCVD method, it may also be formed by a sputtering method. In the case of forming the buffer layer **102** by a sputtering method, it is possible to suppress the temperature of the substrate **101** at low temperature during the formation of the buffer layer **102**, and thus even in the case of using the substrate **101** made of a material having a property that is decomposed at high temperature, the respective layers can be preferably formed on the substrate **101** without damaging the substrate **101**.

<Ground Layer>

When the monocrystal ground layer **103** is laminated on the buffer layer **102**, the ground layer **103** can be laminated with much higher crystallinity. Although the ground layer **103** may be $\text{Al}_x\text{Ga}_y\text{In}_z\text{N}$ ($0 \leq x \leq 1$, $0 \leq y \leq 1$, $0 \leq z \leq 1$, $x+y+z=1$), the under-layer **103** having a good crystallinity can be preferably formed using $\text{Al}_x\text{Ga}_{1-x}\text{N}$ ($0 \leq x < 1$).

The thickness of the under-layer **103** is preferably equal to or more than 0.1 μm , more preferably equal to or more than 0.5 μm , and most preferably equal to or more than 1 μm . By forming the under-layer with a thickness equal to or more than 1 μm , a layer of $\text{Al}_x\text{Ga}_{1-x}\text{N}$ having a good crystallinity can be easily obtained.

However, in order to form the under-layer **103** with a good crystallinity, it is preferable that the under-layer **103** is not doped with impurities. However, in the case where the p-type or n-type conductivity is necessary, an acceptor impurity or a donor impurity may be added.

<N-Type Semiconductor Layer>

As illustrated in FIG. 3, it is preferable that the n-type semiconductor layer **104** is comprised of an n-contact layer **104a** and an n-clad layer **104b**. In this case, it is also possible that the n-contact layer **104a** also serves as the n-clad layer **104b**.

The n-contact layer **104a** is a layer for installing an n-type electrode **108**. It is preferable that the n-contact layer **104a** is made of an $\text{Al}_x\text{Ga}_{1-x}\text{N}$ layer ($0 \leq x < 1$, preferably $0 \leq x \leq 0.5$, and more preferably $0 \leq x \leq 0.1$).

Also, it is preferable that the n-contact layer **104a** is doped with an n-type impurity. If the n-type impurity is contained at density of 1×10^{17} to $1 \times 10^{20}/\text{cm}^3$, and preferably at density of 1×10^{18} to $1 \times 10^{19}/\text{cm}^3$, it is advantageous in maintaining a good ohmic contact with the n-type electrode **108**. The n-type impurity, although not specially limited, for example, may be Si, Ge, Sn, or the like, and preferably may be Si or Ge.

Preferably, the thickness of the n-contact layer **104a** is within the range of 0.5 to 5 μm , and more preferably, within the range of 1 to 3 μm . If the thickness of the n-contact layer **104a** is in the above-described range, the crystallinity of the semiconductor can be maintained well.

The n-clad layer **104b** is a layer that performs carrier injection and carrier confinement in the light-emitting layer **105**. The n-clad layer **104b** can be formed of AlGaIn , GaInN , and the like. Also, the n-clad layer **104b** may have a superlattice structure in which the above-described structures are heterojunctioned or laminated plural times. In the case of forming the n-clad layer **104b** with GaInN , it is undoubtedly preferable to form the n-clad layer with a size that is larger than a band gap of GaInN of the light-emitting layer **105**.

The thickness of the n-clad layer **104b**, although not specially limited, may be preferably within the range of 0.005 to 0.5 μm , and more preferably within the range of 0.005 to 0.1 μm . The n-type doping density of the n-clad layer **104b** is preferably 1×10^{17} to $1 \times 10^{20}/\text{cm}^3$, and more preferably 1×10^{18} to $1 \times 10^{19}/\text{cm}^3$. If the doping density is in this range, it is advantageous in maintaining a good crystallinity and in reducing the operation voltage of the device.

At this time, in the case where the n-clad layer **104b** is a layer including the superlattice structure, it may include a structure in which an n-side first layer comprised of a group III nitride semiconductor having a thickness equal to or less than 100 \AA and an n-side second layer comprised of a group III nitride semiconductor having a composition different from that of the n-side first layer and having a thickness equal to or less than 100 \AA are laminated. Also, the n-clad layer **104b** may include a structure in which the n-side first layer and the n-side second layer are alternately and repeatedly laminated. Also, preferably, any one of the n-side first layer and the n-side second layer has a construction that is in contact with an active layer (light-emitting layer **105**).

The n-side first layer or the n-side second layer may be a composition of an AlGaIn system (which may be simply described as AlGaIn) including Al, a GaInN system (which may be simply described as GaInN) including In, and GaN. Also, the n-side first layer or the n-side second layer may be a GaInN/GaIn alternating structure, an $\text{AlGaIn}/\text{GaIn}$ alternating structure, a $\text{GaInN}/\text{AlGaIn}$ alternating structure, a $\text{GaInN}/\text{GaInN}$ alternating structure having different composition (herein, the term "different composition" indicates that the composition ratio of the respective elements is different, and the same may be said hereinafter), or an $\text{AlGaIn}/\text{AlGaIn}$ alternating structure having different composition.

The superlattice layers of the n-side first layer and the n-side second layer are preferably equal to or less than 60 \AA , more preferably equal to or less than 40 \AA , and most prefer-

ably within the range of 10 Å to 40 Å, respectively. If the thickness of the n-side first layer and the n-side second layer that constitute the superlattice layer exceeds 100 Å, the crystal may be defective, and thus it is not preferable.

The n-side first layer and the n-side second layer may have a doped structure or a combination of doped/undoped structures. As doping impurities, known impurities in the related art may be applied to the above-described material composition without any limitation. For example, in the case of using the GaInN/GaN alternating structure or the GaInN/GaInN alternating structure having different composition as the n-clad layer **104b**, Si is suitable as an impurity. Also, the n-side superlattice multi-layer as described above may be manufactured by properly turning on/off the doping even if the same composition represented by the GaInN, AlGaIn, or GaN is used. The n-side first layer and the n-side second layer that constitute the superlattice layer may be manufactured by using a material with the same composition and properly turning on/off the doping.

<Light Emitting Layer>

The light-emitting layer **105** has a multiple quantum well structure as illustrated in FIG. 3. In the multiple quantum well structure of the light-emitting layer **105** illustrated in FIG. 3, the $\text{Ga}_{1-y}\text{In}_y\text{N}$ ($0 \leq y < 0.4$) becomes the well layer **105b**, and the $\text{Al}_z\text{Ga}_{1-z}\text{N}$ ($0 \leq z < 0.3$) having a band gap energy that is larger than that of the well layer **105b** becomes a barrier layer **105a**. The impurities may or may not be doped into the well layer **105b** and the barrier layer **105a**. The well layer **105b** may have a thickness enough to obtain the quantum effect, and for example, the thickness of the well layer **105b** may be within the range of 1 to 10 nm, and preferably within the range of 2 to 6 nm, which is preferable in view of light emission. Herein, the light-emitting layer **105** may have a multiple quantum well structure or a single quantum well structure.

<P-Type Semiconductor Layer>

As illustrated in FIG. 3, the p-type semiconductor layer **106** is comprised of a p-clad layer **106a** and a p-contact layer **106b**. In this case, it is also possible that the p-contact layer **106b** also serves as the p-clad layer **106a**.

The p-clad layer **106a** is a layer that performs carrier confinement and carrier injection in the light-emitting layer **105**. The p-clad layer **106a**, although not specially limited, may have a composition that becomes larger than the band gap energy of the light-emitting layer **105** and may confine the carrier of the light-emitting layer **105**, and preferably, may be $\text{Al}_x\text{Ga}_{1-x}\text{N}$ ($0 < x \leq 0.4$). If the p-clad layer **106a** is comprised of the AlGaIn as described above, it is preferable in confining the carrier of the light-emitting layer **105**.

The p-clad layer **106a**, although not specially limited, may have a thickness preferably within the range of 1 to 400 nm, and more preferably within the range of 5 to 100 nm.

Also, the p-type doping density of the p-clad layer **106a** is preferably within the range of 1×10^{18} to $1 \times 10^{21}/\text{cm}^3$, and more preferably within the range of 1×10^{19} to $1 \times 10^{20}/\text{cm}^3$. If the p-type doping density is in this range, a good p-type crystal is obtained without deteriorating the crystallinity.

Also, the p-clad layer **106a** may be a layer having a superlattice structure. In the case of making the p-clad layer **106b** as a layer including the superlattice structure, it may include a structure in which a p-side first layer comprised of a group III nitride semiconductor having a thickness equal to or less than 100 Å and a p-side second layer comprised of a group III nitride semiconductor having a composition different from that of the p-side first layer and having a thickness equal to or less than 100 Å are laminated. Also, it may include a structure in which the p-side first layer and the p-side second layer are alternately and repeatedly laminated.

The p-side first layer or the p-side second layer may be a different composition, and for example, may be any composition of AlGaIn, GaInN, or GaN, or may be a GaInN/GaN alternating structure, an AlGaIn/GaN alternating structure, or a GaInN/AlGaIn alternating structure.

In the present invention, it is preferable that the p-side first layer or the p-side second layer is a AlGaIn/AlGaIn alternating structure or an AlGaIn/GaN alternating structure.

The superlattice layers of the p-side first layer and the p-side second layer are preferably equal to or less than 60 Å, more preferably equal to or less than 40 Å, and most preferably within the range of 10 to 40 Å. If the thickness of the p-side first layer and the p-side second layer that constitute the superlattice layer exceeds 100 Å, the crystal may be greatly defective, and thus it is not preferable.

The p-side first layer and the p-side second layer may be a doped structure or a combination of doped/undoped structures. As doping impurities, known impurities in the related art may be applied to the above-described material composition without any limitation. For example, in the case of using the AlGaIn/GaN alternating structure or the AlGaIn/AlGaIn alternating structure having different composition as the p-clad layer, Mg is suitable as an impurity. Also, the p-side first layer and the p-side second layer that constitute the superlattice layer may be manufactured by using a material with the same composition and properly turning on/off the doping.

The p-contact layer **106b** is a layer for installing the p-type electrode **111** that is a positive electrode. It is preferable that the p-contact layer **106b** is made of an $\text{Al}_x\text{Ga}_{1-x}\text{N}$ layer ($0 \leq x \leq 0.4$). If the Al composition is in the above-described range, it is preferable in maintaining a good crystallinity and a good ohmic contact with the p-type electrode **111**.

If the p-type contact layer **106b** contains the p-type impurity (dopant) at density of 1×10^{18} to $1 \times 10^{21}/\text{cm}^3$, and preferably at density of 5×10^{19} to $5 \times 10^{20}/\text{cm}^3$, it is preferable in maintaining a good ohmic contact, preventing crack generation, and maintaining a good crystallinity. The p-type impurity, although not specially limited, for example, may be Mg or the like.

The thickness of the p-contact layer **106b**, although not specifically limited, is preferably 0.01 to 0.5 μm, and more preferably 0.05 to 0.2 μm. If the thickness of the p-contact layer **106b** is in this range, it is preferable in view of the light emission output.

<P-Type Electrode>

The p-type electrode **111**, as illustrated in FIG. 4, includes a transparent electrode **109**, a junction layer **110**, and a bonding pad electrode **120**.

As illustrated in FIG. 4, a hole portion **109a**, through which the upper surface **106c** of the laminated semiconductor layer **20** is exposed, is formed in a transparent electrode **109**. Also, as illustrated in FIG. 1, in an area where the hole portion **109a** is not formed on the upper surface **109c** of the transparent electrode **109**, a transparent protection film **10a** is formed to cover the transparent electrode **109**. In other words, an area where the hole portion **109a** is formed is an opening **10d** in which a portion of the transparent protection film **10a** is open.

On the bottom surface **109b** and the inner wall **109d** of the hole portion **109a** exposed from the opening **10d**, the junction layer **110** is formed to cover the hole portion **109a** and the opening **10d**.

Also, in the semiconductor light-emitting device **1** of the present embodiment, the junction resistivity between the junction layer **110** and the laminated semiconductor layer **20** is higher than the junction resistivity between the junction layer **110** and the transparent electrode **109**. Therefore, the

junction layer **110** may ohmically contact the transparent electrode **109**, and the junction layer **110** may not ohmically contact the upper surface **106c** of the laminated semiconductor layer **20**. In this case, in the semiconductor light-emitting device **1** of the present embodiment, the sufficient current is supplied to the light-emitting layer **105** that is positioned in the vicinity of the inner wall **109d** of the hole portion **109a** of the transparent electrode **109**, and the strong light emission is obtained in the light-emitting layer **105** that is positioned in the vicinity of the inner wall **109d** of the hole portion **109a**. Also, the light emission distribution is formed in which the light emission from the light-emitting layer **105** radially diminishes from the inner wall **109d** of the hole portion **109a** toward the outside. Also, in the semiconductor light-emitting device **1** of the present embodiment, the amount of the current supplied to the light-emitting layer **105**, which is positioned inside of the hole portion **109a** of the transparent electrode **109** as planarly viewed, is small. Also, the light-emitting from the light-emitting layer **105**, which is positioned inside of the hole portion **109a** of the transparent electrode **109** as planarly viewed, may be small.

Also, on the junction layer **110**, the bonding pad electrode **120** is formed to cover the junction layer **110**. As illustrated in FIG. 4, an outer edge portion of the junction layer **110** and an outer edge portion of the bonding pad electrode **120** (a metal reflection layer **117** and a bonding layer **119**) are arranged on the transparent protection film **10a**. Also, the bonding pad electrode **120** is provided with an slope **119c**, which is made gradually thinner toward the outside and is formed on an outer circumference portion **120d** of the bonding pad electrode **120**. In the semiconductor light-emitting device **1** of the present embodiment, as illustrated in FIG. 4, the outer edge portion of the bonding pad electrode **120** is covered by an edge portion protection film **10b**.

[Transparent Electrode]

The transparent electrode **109**, as illustrated in FIG. 1, is installed on the upper surface **106c** of the p-type semiconductor layer **106**, and as illustrated in FIG. 4, is provided with the hole portion **109a** through which the upper surface **106c** of the laminated semiconductor layer **20** is exposed. The planar shape of the hole portion **109a** of the transparent electrode **109** may be an arbitrary shape such as circular shape or polygonal shape, and, although not specifically limited, is preferably a circular shape to make the bonding work easy as illustrated in FIG. 2.

Also, the transparent electrode **109**, as illustrated in FIG. 2, as planarly viewed, is formed to cover the almost entire upper surface **106c** of the p-type semiconductor layer **106**. However, the transparent electrode **109** is not limited to such a shape, and may be formed in a lattice shape or in a tree shape at predetermined intervals.

Also, the hole portion **109a** of the transparent electrode **109** may be formed anywhere on the upper surface **106c** of the p-type semiconductor layer **106**. For example, it may be formed on a position that is farthest from the n-type electrode **108**, or may be formed in the center of the semiconductor light-emitting device **1**. However, if the bonding pad electrode **120** is formed on a position that is too close to the n-type electrode **108**, short circuiting may occur between the wires or balls when the wire is bonded to the bonding pad electrode **120** that is formed on the hole portion **109a**, and thus it is not preferable.

It is preferable that the transparent electrode **109** have a small contact resistance with the p-type semiconductor layer **106**. Also, it is preferable that the transparent electrode **109** have a superior light permeability in order to efficiently extract the light from the light-emitting layer **105** toward a

side on which the p-type electrode **111** is formed. Also, in order to uniformly diffuse current over the whole surface of the p-type semiconductor layer **106**, it is preferable that the transparent electrode **109** have a superior conductivity.

From the above-described contents, as the material of the transparent electrode **109**, it is preferable to use a transparent conductive material selected from the group consisting of zinc sulfide, chromium sulfide, and a conductive oxide comprising any one kind selected from the group consisting of In, Zn, Al, Ga, Ti, Bi, Mg, W, Ce, Sn, and Ni.

Also, it is preferable that the conductive oxide be ITO (Indium Tin Oxide ($\text{In}_2\text{O}_3\text{—SnO}_2$)), IZO (Indium Zinc Oxide ($\text{In}_2\text{O}_3\text{—ZnO}$)), AZO (Aluminum Zinc Oxide ($\text{ZnO—Al}_2\text{O}_3$)), GZO (Gallium Zinc Oxide ($\text{ZnO—Ga}_2\text{O}_3$)), fluorine doped tin oxide, titanium oxide, or the like.

Also, it is preferable that the transparent electrode **109** have a crystallized structure from the viewpoint of the adhesion and transparency with the junction layer **110**. In particular, it is preferable that the transparent electrode **109** include a transparent electrode (for example, ITO or IZO) including In_2O_3 crystal having a hexagonal crystal structure or a bixbyite structure.

In the case where the transparent electrode **109** is made of a crystallized IZO, it may be the IZO that includes an In_2O_3 crystal having a bixbyite crystal structure or the IZO that includes an In_2O_3 crystal having a hexagonal crystal structure. In particular, the IZO that includes the In_2O_3 crystal having the hexagonal crystal structure is preferable. The crystallized IZO film has good adhesion with the junction layer **110** and the p-type semiconductor layer **106** in comparison to the IZO film in an amorphous state, and thus it is very preferable.

Also, as the IZO film, it is preferable to use a composition that has the lowest resistivity. For example, the ZnO density inside the IZO is preferably within the range of 1 to 20% by mass, and more preferably within the range of 5 to 15% by mass. Particularly, it is preferable that the ZnO density be 10% by mass.

Also, the thickness of the IZO film is preferably within the range of 35 nm to 10000 nm (10 μm) in which low resistivity and high light permeability can be obtained. Further, from a view point of production cost, the thickness of the IZO film is preferably equal to or less than 1000 nm (1 μm).

[Junction Layer]

The junction layer **110** is laminated between the bonding pad electrode **120**, and the laminated semiconductor layer **20** and the transparent electrode **109** in order to improve the junction strength of the bonding pad electrode **120** against the laminated semiconductor layer **20** and the transparent electrode **109**.

As illustrated in FIG. 4, the junction layer **110** is formed to be installed inside the hole portion **109a** of the transparent electrode **109** and the opening **10d** of the transparent protection film **10a**. In the present embodiment, the junction layer **110** is successively formed to cover the bottom surface **109b** (the upper surface **106c** of the laminated semiconductor layer **20**) and the inner wall **109d** of the hole portion **109a**, and the end portion **10c** of the transparent protection film **10a**. Accordingly, it is possible to obtain the high junction strength between the junction layer **110**, and the laminated semiconductor layer **20** and the transparent electrode **109**.

Also, the thickness of the junction layer **110** is roughly uniform within the hole portion **109a** and on the inner wall surface of the opening **10d** of the transparent protection film **10a**. Also, on the outside of the opening **10d**, the junction

layer **110** is gradually thinner toward the outside, and thus an slope **110c** is formed on the outer circumference portion **110d** of the junction layer **110**.

Also, it is preferable that the junction layer **110** have transparency. In the case where the junction layer **110** has transparency, the light radiated from the light-emitting layer **105** onto the bonding pad electrode **120** can be transmitted through the junction layer **110** without loss. More specifically, in the case where the junction layer **110** has transparency, a portion of the light from the light-emitting layer **105** is transmitted through the transparent electrode **109** and the junction layer **110**, and then is reflected by the bonding pad electrode **120** (in the present embodiment, the metal reflection layer **117**) in the interface of the junction layer **110** and the bonding pad electrode **120**. The light reflected by the bonding pad electrode **120** is introduced into the inside of the laminated semiconductor layer **20** again, repeats transmission and reflection, and then is extracted from a place except for the area where the bonding pad electrode **120** is formed to the outside of the semiconductor light-emitting device **1**. Accordingly, in the case where the junction layer **110** has transparency, the light from the light-emitting layer **105** can be very efficiently extracted to the outside of the semiconductor light-emitting device **1**.

The junction layer **110** is made of the material with the property in which the junction resistivity to the laminated semiconductor layer **20** is higher than the junction resistivity to the transparent electrode **109**. Specifically, it is preferable that the junction layer **110** be made of at least one kind of element selected from the group consisting of Al, Ti, V, Cr, Mn, Co, Zn, Ge, Zr, Nb, Mo, Ru, Hf, Ta, W, Re, Rh, Ir, and Ni. For example, the transparent electrode **109** is formed of IZO, the upper surface **106c** of the laminated semiconductor layer **20** is prepared using the p-type contact layer **106b** made of p-GaN (Mg doping), and the junction layer **110** is formed of the above-described materials. Because of these configurations, the junction resistivity between the junction layer **110** and the laminated semiconductor layer **20** is higher than the junction resistivity between the junction layer **110** and the transparent electrode **109**, and also, the bonding pad electrode **120** has the good transparency and junction strength against the laminated semiconductor layer **20** and the transparent electrode **109**.

The junction layer **110** is made of preferably at least one kind of element selected from the group consisting of Cr, Ti, W, Mo, Zr, Hf, Co, Rh, Ir, and Ni, and more preferably at least one kind of element selected from the group consisting of Cr, Ti, W, Mo, Rh, Co, and Ni. In particular, by using a metal such as Cr, Ti, Mo, Ni, Co as the material of the junction layer **110**, the junction strength of the bonding pad electrode **120** against the laminated semiconductor layer **20** and the transparent electrode **109** can be especially increased.

Also, in the case where, for example, the transparent electrode **109** is made of a metal oxide, such as IZO, ITO, and the bonding pad electrode **120** is made of Ag, Al, or the like, as materials of the junction layer **110**, it is especially preferable to use Cr, from which a superior junction property is obtained, with respect to both the metal oxide and the Ag and Al.

Also, it is preferable that the junction layer **110** be a thin film of which the maximum thickness is equal to or more than 10 Å and equal to or less than 400 Å. By making the maximum thickness of the junction layer **110** in the above-described range, superior transparency is obtained and thus the light from the light-emitting layer **105** can be effectively transmitted without shielding. In this case, if the maximum thickness becomes less than 10 Å, the strength of the junction layer **110** is lowered, and thus the junction strength of the

bonding pad electrode **120** against the laminated semiconductor layer **20** and the transparent electrode **109** is lowered to cause a non-preferable result.

[Bonding Pad Electrode]

The bonding pad electrode **120** is comprised of a laminated body in which the metal reflection layer **117** and the bonding layer **119** are laminated in order from the side of the transparent electrode **109**. In this case, the bonding pad electrode **120** may be a single-layer structure comprised of only the bonding layer **119**, a single-layer structure comprised of only the metal reflection layer **117**, or a three-layer structure that is obtained by inserting a barrier layer between the metal reflection electrode **117** and the bonding layer **119**. In this case, metal elements, which form the junction layer **110**, the metal reflection layer **117**, the bonding layer **119**, and the barrier layer, may include the same metal element or a combination of different metal elements.

In the present embodiment, although the reflection ratio of the bonding pad electrode **120** is greatly changed according to the constituent materials of the metal reflection layer **117**, the reflection ratio is preferably equal to or more than 60%. Further, the reflection ratio of the bonding pad electrode **120** is more preferably equal to or more than 80%, and further more preferably equal to or more than 90%. The reflection ratio can be relatively easily measured by a spectrophotometer and so on. However, since the bonding pad electrode **120** itself has a small area, it is difficult to measure the reflection ratio. Accordingly, for example, a "dummy substrate" which is made of transparent glass and has a larger area may be put into a chamber for forming the bonding pad electrode, and the same bonding pad electrode may be formed on the dummy substrate while the bonding pad electrode is formed, so that the reflection ratio of the bonding pad electrode formed on the dummy substrate may be measured.

As for the area of the bonding pad electrode **120**, it is preferable that the bonding pad electrode **120** have a larger area to facilitate the bonding work. However, when the area of the bonding pad electrode **120** is large, the current amount supplied from the bonding pad electrode **120** is small in the light-emitting layer **105** that planarly overlaps the bonding pad electrode **120**, and the amount of the light emission from the light-emitting layer **105** is small. Therefore, when the area of the bonding pad electrode **120** is larger, there is a problem that the amount of the light emission from the light-emitting layer **105** is insufficient. Specifically, for example, if the area of the bonding pad electrode **120** exceeds a half of the area on the transparent electrode **109**, the light emission amount of the light-emitting layer **105** that planarly overlaps the bonding pad electrode **120** is small, and thus the output deteriorates remarkably. In contrast, if the area of the bonding pad electrode **120** is too small, it becomes difficult to perform the bonding work, and thus the yield of the product deteriorates. Accordingly, the area of the bonding pad electrode **120** is preferably somewhat larger than the diameter of a bonding ball, and specifically in a roughly circular shape of which the upper surface's diameter is about 100 μm and of which the diameter becomes larger toward the side of the transparent protection film **10a**.

<Metal Reflection Layer>

The metal reflection layer **117** is formed to cover the junction layer **110**. On the outer circumference portion of the metal reflection layer **117**, an slope **117c**, which is made gradually thinner toward the outside, is formed. Accordingly, the metal reflection layer **117** is formed to completely cover the forefront end portion of the transparent protection film **10a** of the slope **110c** of the junction layer **110**, that is, a boundary portion of the junction layer **110** that makes a

15

contour-line as seen planarly viewed. In other words, as planarly viewed, the metal reflection layer 117 is formed to cover the junction layer 110 and further to project up to the outside of the junction layer 110, and thus no portion of the junction layer 110 is exposed from the lower part of the metal reflection layer 117.

The metal reflection layer 117 illustrated in FIG. 1 is made of preferably a metal having a high reflection ratio, and more preferably a platinum group metal, such as Ru, Rh, Pd, Os, Ir, Pt, Al, Ag, Ti, or an alloy including at least one kind of these metals. By forming the metal reflection layer 117 with one of the above-described materials, the light from light-emitting layer 105 can be effectively reflected. Among them, Al, Ag, Pt, or an alloy including at least one kind of these metals is superior on the point that it is easy to obtain and easy to handle. Also, Rh, Pd, Ir, Pt, or an alloy including at least one kind of these metals is appropriately used as the metal reflection layer 117 in view of its light reflection.

Also, it is preferable that the metal reflection layer 117 have a maximum thickness that is larger than the maximum thickness of the junction layer 110. By making the maximum thickness of the metal reflection layer 117 larger than the maximum thickness of the junction layer 110, the junction layer 110 is covered by the metal reflection layer 117 more reliably and completely.

Also, the maximum thickness of the metal reflection layer 117 is preferably 20 to 3000 nm. If the metal reflection layer 117 is thinner than this thickness range, a sufficient reflection effect may not be obtained. If the metal reflection layer 117 is thicker than the thickness range, any special advantage is not obtained, but only the processing time is lengthened with the waste of materials. The thickness of the metal reflection layer 117 is more preferably 50 to 1000 nm, and most preferably 100 to 500 nm.

<Bonding Layer>

The bonding layer 119 is formed to cover the metal reflection layer 117. Also, on the outer circumference portion of the bonding layer 119 (the outer circumference portion 120d of the bonding pad electrode 120), an slope 119c, which is made gradually thinner toward the outside, is formed. Accordingly, the bonding layer 119 is formed to completely cover the forefront end portion of the transparent protection film 10a of the slope 117c of the metal reflection layer 117, that is, a boundary portion of the metal reflection layer 117 that makes a contour-line as seen from a plane. That is, as seen from a plane, the bonding layer 119 is formed to cover the metal reflection layer 117 and further to project up to the outside of the metal projection layer 117, and thus no portion of the metal reflection layer 117 is exposed from the lower part of the bonding layer 119.

It is preferable that the bonding layer 119 as illustrated in FIG. 1 be made of Au, Al, or an alloy including at least one kind of these metals. Au and Al are metals having good adhesion with gold balls, which are often used as bonding balls, and by using Au, Al, or an alloy including at least one kind of these metals as the bonding layer 119, the bonding layer 119 has superior adhesion with the bonding wires. Among them, Au is particularly preferable.

Also, it is preferable that the bonding layer 119 be formed so that the maximum thickness of the bonding layer 119 is larger than that of the junction layer 110 and the metal reflection layer 117. By making the maximum thickness of the bonding layer 119 larger than that of the junction layer 110 and the metal reflection layer 117, the metal reflection layer 117 is covered by the bonding layer 119 more certainly and completely.

16

Also, the maximum thickness of the bonding layer 119 is preferably equal to or more than 50 nm and equal to or less than 2000 nm, and more preferably equal to or more than 100 nm and equal to or less than 1500 nm. If the maximum thickness of the bonding layer 119 is too thin, the adhesion with the bonding balls becomes insufficient, while if the maximum thickness of the bonding layer 119 is too thick, any special advantage is not obtained, but only the cost is increased.

<Barrier Layer>

The barrier layer is arranged between the metal reflection layer 117 and the bonding layer 119, and reinforces the strength of the entire bonding pad electrode 120. The barrier layer is made of a relatively strong metal material or is sufficiently thick. As a material of the barrier layer, Ti, Cr, Al, or the like, may be used, but it is preferable to use Ti having superior strength. Also, the maximum thickness of the barrier layer is preferably 20 to 3000 nm. If the barrier layer is too thin, a sufficient strength reinforcement effect is not obtained, while if the barrier layer is too thick, no special advantage is obtained, but only the cost is increased. The thickness of the barrier layer is more preferably 50 to 1000 nm, and most preferable 100 to 500 nm.

In this case, if the metal reflection layer 117 is mechanically strong, it is not surely necessary to form the barrier layer. For example, in the case where the metal reflection layer 117 is made of Al or Pt, the barrier layer is not surely necessary. [Transparent Protection Film]

The transparent protection film 10a is to protect the transparent electrode 109 and the junction layer 110. The transparent protection film 10a, as illustrated in FIG. 1 and FIG. 2, is formed to cover an area where the hole portion 109a is not formed on the upper surface 109c of the transparent electrode 109, and an area where the hole portion 109a is formed becomes the opening 10d. In the present embodiment, as illustrated in FIG. 4, the junction layer 110 is formed to be in contact with the inner wall surface of the opening 10d, and an outer edge portion of the junction layer 110 is arranged to be in contact with the transparent protection film 10a. By the transparent protection film 10a, the portion that is in contact with the transparent protection film 10a of the junction layer 110 is prevented from being in contact with air or moisture.

Also, in the present embodiment, as illustrated in FIG. 4, outer edge portions of the metal reflection layer 117 and the bonding layer 119 which constitute the bonding pad electrode 120 are arranged to be in contact with the transparent protection film 10a, and the entire outer surface of the junction layer 110 that is not in contact with the laminated semiconductor layer 20 and the transparent electrode 109 is surrounded by the transparent protection film 10a and the bonding pad electrode 120, so that the junction layer 110 is effectively prevented from being in contact with air or moisture.

The transparent protection film 10a is formed of preferably a material which is transparent and has superior adhesion with the respective layers of the transparent electrode 109, the junction layer 110, and the bonding pad electrode 120, and more particularly SiO₂.

The thickness of the transparent protection film 10a is preferably 20 to 500 nm, and more preferably 50 to 300 nm. If the thickness of the transparent protection film 10a is less than this thickness range, a sufficient effect of protecting the transparent electrode 109 and the junction layer 110 may not be obtained. Also, if the thickness of the transparent protective film 10a exceeds the thickness range, transparency deteriorates, and a trouble may occur in extracting the light. Also, if the thickness of the transparent protective film 10a exceeds the thickness range, the depth that is obtained by adding the

depth of the opening **10d** and the depth of the hole portion **109a** is increased, and this may cause a trouble in adhesion between the junction layer **110**, and the hole portion **109a** and the inner wall surface of the opening **10d**.

[Edge Portion Protection Film]

The edge portion protection film **10b** prevents the junction layer **110** from being in contact with air or moisture and prevents the bonding pad electrode **120** from peeling off from the semiconductor light-emitting device **1** to improve the junction strength of the bonding pad electrode **120**. The edge portion protection film **10b**, as illustrated in FIG. **2** and FIG. **4**, is roughly in the form of a donut that exposes the center portion of the bonding pad electrode **120** as planarly viewed. Also, the edge portion protection film **10b**, as illustrated in FIG. **1** and FIG. **2**, is arranged over a juncture portion of the outer edge portion (contour-line) of the bonding pad electrode **120** and the transparent protective film **10a**, and covers the outer edge portion of the bonding pad electrode **120** as planarly viewed. Accordingly, in the present embodiment, as illustrated in FIG. **4**, the outer edge portion of the bonding pad electrode **120** is inserted between the transparent protective film **10a** and the edge portion protection film **10b**.

As the area of the edge portion protection film **10b** becomes wider around the boundary portion of the bonding pad electrode **120** and the transparent protective film **10a**, the effect obtained by installing the edge portion protection film **10b** becomes greater. However, if the area of the edge portion protection film **10b** is widened, the area of the bonding pad electrode **120** that is exposed from the edge portion protection film **10b** becomes smaller, and this may cause trouble in workability of the bonding work. Also, the edge portion protection film **10b** may deteriorate transparency of the area where the bonding pad electrode **120** is not formed to cause trouble in extracting the light. Accordingly, it is preferable that the edge portion protection film **10b** completely cover the boundary portions of the bonding pad electrode **120** and the transparent protective film **10a**, and completely exposes the top head portion of the bonding pad electrode **120**. Specifically, it is preferable that the edge portion protection film **10b** have a width of 5 to 10 μm around the boundary portion of the bonding pad electrode **120** and the edge portion protection film **10b**.

The edge portion protection film **10b** is transparent, and is formed of preferably a material having superior adhesion between the transparent protective film **10a** and the bonding pad electrode **120**, and more preferably the same material as the transparent protective film **10a**. Specifically, the transparent protective film **10a** and the edge portion protection film **10b** may be formed of SiO_2 . In the case where the edge portion protection film **10b** and the transparent protective film **10a** are formed of the same material, the adhesion between the edge portion protection film **10b** and the transparent protective film **10a** becomes remarkably good, and thus the effect obtained by installing the edge portion protection film **10b** can be much more improved.

<N-Type Electrode>

As illustrated in FIG. **1**, the n-type electrode **108** is formed on the exposed surface **104c** of the n-type semiconductor layer **104**. The exposed surface **104c** of the n-type semiconductor layer **104** is exposed by partially cutting and removing the light-emitting layer **105** and the p-type semiconductor layer **106** by a means such as etching.

As illustrated in FIG. **2**, as planarly viewed, the n-type electrode **108** is in a circular shape. However, the shape of the n-type electrode **108** is not limited thereto, and may be an arbitrary shape such as a multi-angle shape. Also, the n-type electrode **108** also serves as a bonding pad, and thus is con-

figured to connect a bonding wire. In this case, as the n-type electrode **108**, various kinds of known compositions or structures may be installed by a common means well known in the technical field.

5 (Method of Manufacturing Semiconductor Light-Emitting Device)

Next, a method of manufacturing a semiconductor light-emitting device of the present invention will be described. The method of manufacturing a semiconductor light-emitting device of the present embodiment is the method of manufacturing the semiconductor light-emitting device **1** as illustrated in FIG. **1**.

In order to manufacture a semiconductor light-emitting device **1** as illustrated in FIG. **1**, a laminated semiconductor layer **20** is first formed on a substrate **101**. By forming a laminated semiconductor layer **20** using the MOCVD method, a good crystallinity can be obtained. However, by optimizing the conditions in the formation of a laminated semiconductor layer **20** using the sputtering method, the crystallinity, which is more superior to that obtained in the MOCVD method, can be obtained.

<Formation of Laminated Semiconductor Layer>

For the formation of the laminated semiconductor **20** in the present embodiment, a substrate **101** such as a sapphire substrate or the like is firstly prepared, and a preprocessing of the substrate **101** is performed. The preprocessing of the substrate **101** may be performed by a method or the like that puts the substrate **101** in a chamber of a sputter device and performs sputtering before the formation of a buffer layer **102**. Specifically, in the chamber, a preprocessing for cleaning an upper surface of the substrate **101** through exposure of the substrate **101** in Ar or N_2 plasma may be performed. By applying plasma of Ar gas or N_2 gas on the substrate **101**, an organic material or oxide attached to the upper surface of the substrate **101** can be removed.

Next, on the upper surface of the substrate **101**, a buffer layer **102** is laminated by a sputtering method. In the case of forming the buffer layer **102** having a monocrystal structure by a sputtering method, it is preferable that the ratio of nitrogen raw material flow rate to the inert gas flow rate in the chamber be 50% to 100%, and preferably 75%.

Also, in the case of forming the buffer layer **102** having a column type crystal (polycrystal) by the sputtering method, it is preferable that the ratio of nitrogen raw material flow rate to the inert gas flow rate in the chamber be 1% to 50%, and preferably 25%. In this case, the buffer layer **102** may also be formed by a MOCVD method in addition to the above-described sputtering method.

After the buffer layer **102** is formed, a monocrystal ground layer **103** is formed on the upper surface of the substrate **101** on which the buffer layer **102** is formed. It is preferable that the ground layer **103** be formed using the sputtering method. In the case of using the sputtering method, it is possible to use the device with a simple construction in comparison to the MOCVD method or MBE method. In the case of forming the ground layer **103** by the sputtering method, it is preferable to form the ground layer using a film-forming method by a reactive sputtering method that circulates a group V raw material such as nitrogen or the like in a reactor.

After the ground layer **103** is formed, the n-type semiconductor layer **104** is formed by laminating an n-contact layer **104a** and an n-clad layer **104b**. The n-contact layer **104a** and the n-clad layer **104b** may be formed by a sputtering method or by a MOCVD method.

Next, the light-emitting layer **105** is formed. The light-emitting layer **105** can be formed by using any one of the sputtering method and the MOCVD method, and it is particu-

larly preferable to use the MOCVD method. Specifically, the lamination of a barrier layer **105a** and a well layer **105b** is alternately repeated, and the barrier layer **105a** is arranged in order on the side of the n-type semiconductor layer **104** and on the side of the p-type semiconductor layer **106**.

Also, the p-type semiconductor layer **106** may be formed by any one of the sputtering method and the MOCVD method, and the p-type semiconductor layer **106** may be formed by sequentially laminating the p-clad layer **106a** and the p-contact layer **106b**.

[Formation of Electrode]

Through the above-described step, the laminated semiconductor layer **20** is formed, and then an n-type electrode **108** and a p-type electrode **111** are formed.

<N-Type Electrode Formation Step>

First, by performing a patterning using a known photolithography method, a portion of the n-contact layer **104a** is exposed by etching a portion of the laminated semiconductor layer **20** in a predetermined area. Next, using a sputtering method or the like, the n-type electrode **108** is formed on the exposed surface **104c** of the n-contact layer **104a**.

<P-Type Electrode Formation Step>

Next, with reference to FIG. 5A to FIG. 5E, a step of manufacturing a p-type electrode **111** will be described. FIG. 5A to FIG. 5E is a view illustrating a step of manufacturing a p-type electrode, and an enlarged cross-sectional view illustrating only a portion of an area on which the p-type electrode **111** is manufactured.

As illustrated in FIG. 5A, in order to manufacture the p-type electrode **111** of the present embodiment, a transparent electrode **109** is first formed on the p-type semiconductor layer **106** of the laminated semiconductor layer **20**. The transparent electrode **109** is formed in a manner that a mask that covers an area except for an area where the transparent electrode **109** is formed, such as the exposed surface **104c** of the n-contact layer **104a** on which the n-type electrode **108** is formed, the transparent electrode **109** is formed on the p-type semiconductor layer **106** using a known method such as a sputtering method, and then the mask is removed. In this case, the transparent electrode **109** may be formed after the n-type electrode **108** is formed, or may be formed before the etching of the laminated semiconductor layer **20** for forming the n-type electrode **108**.

Next, as illustrated in FIG. 5A, a transparent protective film **10a** is formed on the upper surface **109c** of the transparent electrode **109**, a resist **21** is coated on the transparent protective film **10a**, and then a drying process is performed.

Next, by removing the resist **21** on a portion that corresponds to the portion on which the bonding pad electrode **120** is formed, a reverse-tapered mask **23** illustrated in FIG. 5B, which has an opening **23a** that is in the form of an inner wall of which the cross-sectional area is gradually widened toward the bottom surface, is formed on the upper surface **109c** of the transparent electrode **109** on which the transparent protective film **10a** is formed. The method of forming the reverse-tapered mask **23** may be a method using the n-type photoresist or a method using an image reversion type photoresist. In the present embodiment, with reference to FIG. 6A to FIG. 6D, a method of forming a mask as illustrated in FIG. 5B using the image reversion type photoresist will be described. FIG. 6A to FIG. 6D is a view illustrating a step of manufacturing a mask illustrated in FIG. 5B, and enlarged cross-sectional views illustrating only an area in which one p-type electrode **111** is formed.

In the present embodiment, as a resist **21**, insoluble resist that is an image reversion type photoresist is used. As the

image reversion type photoresist, for example, AZ5200NJ (product name: product of AZ Electronic Materials) may be used.

Next, as illustrated in FIG. 6A, a mask **25** is arranged to cover a predetermined position on the upper side of the resist **21**, and as indicated by an arrow in FIG. 6A, light of a predetermined intensity and wavelength is radiated from the side of the mask **25** to the side of the resist **21**. Accordingly, an optical reaction of the resist **21** on a portion, to which the light is radiated, occurs to form a soluble portion **22**. Since this optical reaction progresses in accordance with the intensity of light, the light reaction progresses fast on the light irradiation surface side, and the light reaction progresses slowly on the side of the transparent electrode **109**. Due to this, the soluble portion **22**, as seen from the cross-section, as illustrated in FIG. 6A, is formed to be in a reverse-tapered shape (reversely inclined shape), in which the side surface of the portion is inwardly receded toward the lower side of the portion. Also, the resist **21** of the portion covered by the mask **25** remains as the insoluble resist (insoluble portion) **21**, and as seen from the cross-section, is formed to be in a tapered shape (inclined shape), in which the side surface is inwardly receded toward the upper side thereof.

Next, using a heating device such as a hot plate or an oven, the substrate is heated, and as illustrated in FIG. 6B, the soluble portion **22** is made to thermally react to form the hardened portion (mask) **23** comprised of crosslinked polymer.

Thereafter, as illustrated in FIG. 6C, the light with the predetermined intensity and wavelength is radiated onto the insoluble resist **21** and the surface side of the hardened portion (mask) **23** comprised of the crosslinked polymer, without using a mask, and an optical reaction of the insoluble resist **21** as described above using FIG. 6A, which has not been transformed into the soluble resist **22**, occurs to form the soluble portion **22**.

Lastly, by dissolving and removing the soluble portion **22** as illustrated in FIG. 6C using a predetermined developing solution, as illustrated in FIG. 6D, the mask **23** comprised of crosslinked polymer, in a reverse-tapered shape (reversely inclined shape), having an opening **23a**, in which the side surface is inwardly receded toward the lower side of the portion, is obtained.

Then, by removing the transparent protective film **10a** that is exposed from the opening **23a** of the mask **23** as illustrated in FIG. 5B using RIE (Reactive Ion Etching) in a direction vertical to the upper surface **109c** of the transparent electrode **109**, as illustrated in FIG. 5C, an opening **10d** is formed, through which the upper surface **109c** of the transparent electrode **109** is exposed for the opening **10d**. Since the RIE (Reactive Ion Etching) is an etching method which has high directivity and low curvature, as seen from the etching direction (upper side in FIG. 5A to FIG. 5E), the transparent protective film **10a** that becomes a shadow of the mask **23** is hardly etched and removed, and as illustrated in FIG. 5C, the end portion **10c** of the transparent protective film **10a** remains.

Thereafter, as illustrated in FIG. 5C, by etching the transparent electrode **109** that is exposed from the opening **10d** of the transparent protection film **10a**, the hole portion **109a** is formed in the transparent electrode **109**. By forming the hole portion **109a**, the inner wall **109d** of the hole portion **109a** that is exposed from the transparent electrode **109** has superior adhesion with the junction layer **110** in comparison to the upper surface **109c** of the transparent electrode **109**.

Here, for example, in the case where the transparent electrode **109** that is etched is an IZO film in an amorphous state,

the hole portion **109a** of a specified shape can be formed due to the superior etching property. The IZO film in an amorphous state can be easily etched with good accuracy using a known etchant (ITO-07N etchant (product of Kanto Chemical Co., Ltd.)). Also, the etching of the IZO film in an amorphous state may be performed using a dry etching device. In this case, Cl₂, SiCl₄, BCl₃, and the like, may be used as an etching gas.

Also, it is preferable that the IZO film in an amorphous state be an IZO film including In₂O₃ crystal of a hexagonal crystal structure or an IZO film including In₂O₃ crystal of a bixbyite structure by performing heat-treatment. By shifting the film in an amorphous state into a structure that includes the crystal by the heat-treatment or the like, the transparent electrode **109** having good transparency and adhesion with the junction layer **110** rather than the amorphous IZO film can be made. However, since it is difficult to perform the etching of the IZO film including In₂O₃ crystal of a hexagonal crystal structure, it is preferable to perform the heat-treatment after the above-described etching process.

In the case of crystallizing the IZO film in an amorphous state, if the film-forming condition, heat-treatment condition, or the like, is different, the crystal structure in the IZO layer becomes different. The heat-treatment for crystallizing the IZO film is performed preferably in the atmosphere that does not include O₂. The atmosphere that does not include O₂ may be an inert gas atmosphere such as N₂ atmosphere, a mixed gas atmosphere including an inert gas such as N₂ and H₂, or the like, and preferably an N₂ atmosphere or a mixed gas atmosphere including N₂ and H₂. In this case, if the heat-treatment of the IZO film is performed in an N₂ atmosphere or a mixed gas atmosphere including N₂ and H₂, for example, it is possible to crystallize the IZO film on a film that includes In₂O₃ crystal of a hexagonal crystal structure and to effectively reduce sheet resistance of the IZO film.

Also, the heat-treatment temperature for crystallizing the IZO film is preferably 500° C. to 1000° C. In the case of performing the heat-treatment at a temperature less than 500° C., the IZO film may not be sufficiently crystallized, and thus the light permeability of the IZO film may not be sufficiently high. In the case of performing the heat-treatment at a temperature exceeding 1000° C., the IZO film may be crystallized, but the light permeability of the IZO film may not be sufficiently high. Also, in the case of performing the heat-treatment at a temperature exceeding 1000° C., the semiconductor layer located below the IZO film may deteriorate.

Next, as illustrated in FIG. 5D, by the sputtering method, the junction layer **110** is formed to cover the bottom surface **109b** and the inner wall **109d** of the hole portion **109a**. In this case, by using the sputtering method that controls the sputter conditions, the junction layer **110** can be formed with high coverage. Accordingly, the junction layer **110** is formed to cover the entire bottom surface **109b** and the entire inner wall **109d** of the hole portion **109a**, the entire surface on the inner wall surface of the opening **10d** of the transparent protective film **10a**, and a portion of the end portion **10c** of the transparent protective film **10a**, and on the outer circumference portion **110d** of the junction layer **110**, an slope **110c**, which is made gradually thinner toward the outside, is formed.

In this case, before the junction layer **110** is formed, it is may preferably perform preprocessing for cleaning the bottom surface **109b** (the upper surface **106c** of the laminated semiconductor layer **20**) and the inner wall **109d** of the hole portion **109a** on which the junction layer **110** is formed. Here, the cleaning method may be a dry process that exposes the transparent electrode to plasma or the like and a wet process that makes the transparent electrode in contact with a chemi-

cal solution, and from the viewpoint of convenience in the process, the dry process is preferable.

Next, by the sputtering method, the metal reflection layer **117** is formed. In this case, in the same manner as the case of forming the junction layer **110**, the sputtering method that controls the sputter conditions is used, and thus the coverage of the metal reflection layer **117** can be heightened. The metal reflection layer **117** is formed, which covers the junction layer **110** and has a slope **117c**, which is formed on the outer circumference portion of the metal reflection layer **117** and is made gradually thinner toward the outside.

Next, by the sputtering method, the bonding layer **119** is formed. In this case, by using the sputtering method that controls the sputter conditions, the bonding layer **119** can be formed with high coverage. The bonding layer **119** (bonding pad electrode **120**) is formed, of which the outer circumference portion is shaped along the inner wall shape of the opening **23a** of the mask **23**, and which covers the metal reflection layer **117** and has an slope **119c**, which is formed on the outer circumference portion **120d** of the bonding layer **119** and is made gradually thinner toward the outside.

Thereafter, by soaking in a resist peel-off solution, the mask **23** comprised of crosslinked polymer is peeled off. Accordingly, as illustrated in FIG. 5E, the bonding pad electrode **120** comprised of the metal reflection layer **117** and the bonding layer **119** is formed.

In the present embodiment, since the mask **23** including the opening **23a** having the inner wall shape, of which the cross-sectional area is gradually widened toward a bottom surface, is formed, and the junction layer **110**, the metal reflection layer **117**, and the bonding layer **119** are formed by the sputtering method having high coverage, layers having different inclination angles are formed according to the thickness of the respective layers including the junction layer **110**, the metal reflection layer **117**, and the bonding layer **119** in an area that becomes a shadow of the mask **23** as seen from the sputter direction. Accordingly, on the outer circumference portions of the junction layer **110**, the metal reflection layer **117**, and the bonding layer **119**, slopes **110c**, **117c**, and **119c**, which are made gradually thinner toward the outer circumference, are formed.

Next, using a known method, the edge portion protection film **10b**, which is roughly in the form of a donut that exposes the center portion of the bonding pad electrode **120** as planarily viewed, and covers the outer edge portion of the bonding pad electrode **120** over a juncture portion of the outer edge portion (contour-line) of the bonding pad electrode **120** and the transparent protective film **10a**, is formed.

In the present embodiment, on the outer circumference portion **120d** of the bonding pad electrode **120**, an slope **119c**, which is made gradually thinner toward the outside, is formed, and the edge portion protection film **10b** is easily formed on the slope **119c** of the bonding pad electrode **120** with a uniform thickness. By this, a portion, in which the edge portion protection film **10b** is not formed on the portion that is a juncture portion of the outer edge portion (contour-line) of the bonding pad electrode **120** and the transparent protective film **10a**, is prevented from occurring, and thus the edge portion protection film **10b** can be easily and closely formed over the portion that is a juncture portion of the outer edge portion (contour-line) of the bonding pad electrode **120** and the transparent protective film **10a** with a uniform thickness.

Accordingly, the semiconductor light-emitting devices **1** having a p-type electrode **111** as illustrated in FIG. 1 to FIG. 3 are formed.

In the semiconductor light-emitting device **1** of the present embodiment, the p-type electrode **111** includes the transpar-

ent electrode 109 containing the hole portion 109a through which the upper surface 106c of the laminated semiconductor layer 20 is exposed; the junction layer 110 formed on the bottom surface 109b and the inner wall 109d of the hole portion 109a; and the bonding pad electrode 120 formed to cover the junction layer 110. Also, the junction resistivity between the junction layer 110 and the laminated semiconductor layer 20 is higher than the junction resistivity between the junction layer 110 and the transparent electrode 109. Therefore, the current from the bonding pad electrode 120 is mainly diffused in the in-plane direction of the transparent electrode 109 from the inner wall 109d of the hole portion 109a of the transparent electrode 109 through the junction layer 110, and is supplied on the upper surface of the laminated semiconductor layer 20. The amount of the current supplied through the transparent electrode 109 among the current supplied to the laminated semiconductor 20 is larger than the amount of the current directly supplied from the junction layer 110 that contacts the laminated semiconductor layer 20.

Accordingly, in the semiconductor light-emitting device 1 of the present embodiment, the amount of the current supplied to the light-emitting layer 105, which is positioned inside of the hole portion 109a of the transparent electrode 109 as planarly viewed, is small. Also, the light-emitting from the light-emitting layer 105, which is positioned inside of the hole portion 109a of the transparent electrode 109 as planarly viewed, is small. Consequently, even though the bonding pad electrode 120, which cover the junction layer 110 formed on the bottom surface 109b and the inner wall 109d of the hole portion 109a of the transparent electrode 109, does not have transparency and shields a light, it is possible to extremely reduce the ratio of the light, which cannot be extracted to the outside of the semiconductor light-emitting device 1 due to shielding of the bonding pad electrode 120, to the light emitted from the light-emitting layer 105. Also, the light extraction efficiency is high, and the light extraction property is good.

Further, in the semiconductor light-emitting device 1 of the present embodiment, the junction layer 110 is formed on the bottom surface 109b (the upper surface 106c of the laminated semiconductor layer 20) and the inner wall 109d of the hole portion 109a of the transparent electrode 109, and the bonding pad electrode 120 is formed to cover the junction layer 110. Therefore, the high junction strength between the bonding pad electrode 120, and the transparent electrode 109 and the laminated semiconductor layer 20 can be obtained by the junction layer 110. Also, the semiconductor light-emitting device 1 of the present embodiment include the p-type electrode 111 with the good junction property.

Further, according to the semiconductor light-emitting device 1 of the present embodiment, since the bonding pad electrode 120 having a slope 119c, which is made gradually thinner toward the outside, formed on the outer circumference portion 120d is formed to cover the junction layer 110, penetration of external air or moisture into the junction layer 110 can be effectively prevented, and thus the superior anticorrosion property thereof can be obtained.

Here, the effect of the semiconductor light-emitting device of the present embodiment will be described taking the semiconductor light-emitting device 1 having the p-type electrode as illustrated in FIG. 11 as an example. In this case, in FIG. 11, only the p-type electrode provided in the semiconductor light-emitting device is illustrated, and the illustration of the substrate and the laminated semiconductor layer is omitted. In the p-type electrode 201 illustrated in FIG. 11, unlike the semiconductor light-emitting device 1 according to the present embodiment, the edge portion protection film 10b is not formed, the hole portion 109a is not formed in the trans-

parent electrode 109, and the side surfaces of the junction layer 210 and the metal reflection layer 217 and the bonding layer 219 constituting the bonding pad electrode 220 are formed almost vertical to the upper surface 109c of the transparent electrode 109.

In the p-type electrode 201 illustrated in FIG. 11, external air or moisture easily invades between the transparent protective film 10a and the metal reflection layer 217 to reach the junction layer 210. If the air or moisture reaches the junction layer 210, the junction layer 210 deteriorates and the life span of the semiconductor light-emitting device is shortened. Particularly, in the case where the junction layer 210 includes Cr, Cr is easily oxidized or hydro-oxidized by the air or moisture having reached the junction layer 210, and thus the junction layer 210 is dissolved and destroyed to cause a serious problem. Further, the oxidation or hydro-oxidation of Cr is accelerated as bias is applied to the semiconductor light-emitting device having the p-type electrode 201 illustrated in FIG. 11, and this may cause the junction layer 210 to be simply dissolved and destroyed.

In contrast, in the semiconductor light-emitting device 1 of the present embodiment, since the bonding pad electrode 120, which is formed to cover the junction layer 110 and has the slope 119c, which is made gradually thinner toward the outside, formed on the outer circumference portion 120d thereof, is provided, no portion of the junction layer 110 is exposed below the bonding pad electrode 120. Accordingly, according to the semiconductor light-emitting device 1 of the present embodiment, penetration of external air or moisture into the junction layer 110 can be effectively prevented by the semiconductor light-emitting device 1, and thus even in the case where the junction layer 110 is made of Cr, it is possible to obtain the superior anticorrosion property and the superior junction property between the bonding pad electrode 120, and the laminated semiconductor layer 20 and the transparent electrode 109 due to the junction layer 110.

Also, in the semiconductor light-emitting device 1 of the present embodiment, if the junction layer 110 is made of at least one kind of element selected from the group consisting of Al, Ti, V, Cr, Mn, Co, Zn, Ge, Zr, Nb, Mo, Ru, Hf, Ta, W, Re, Rh, Ir, and Ni, and is a thin film of which the maximum thickness is equal to or more than 10 Å and equal to or less than 400 Å, it is possible to even more improve the junction between the bonding pad electrode 120, and the laminated semiconductor layer 20 and the transparent electrode 109.

Further, in the semiconductor light-emitting device 1 of the present embodiment, since the transparent protective film 10a is formed to cover an area where the hole portion 109a is not formed on the upper surface 109c of the transparent electrode 109, and the outer edge portion of the junction layer 110 and the outer edge portion of the bonding pad electrode 120 are arranged on the transparent protective film 10a, further more superior anticorrosion and junction properties can be obtained.

Also, in the semiconductor light-emitting device 1 of the present embodiment, the bonding pad electrode 120 includes a metal reflection layer 117 and the bonding layer 119. No portion of the junction film 110 is exposed from the lower part of the metal reflection layer 117, no portion of the metal reflection layer 117 is exposed from the lower part of the bonding layer 119, and the junction layer 110 is doubly covered by the metal reflection layer 117 and the bonding layer 119. Further, in the semiconductor light-emitting device 1 of the present embodiment, the outer edge portion of the bonding pad electrode 120 is arranged on the transparent protective film 10a. Accordingly, in the semiconductor light-emitting device 1 of the present embodiment, external air or

moisture is unable to invade the junction layer **110** of the semiconductor light-emitting device **1** without passing through the junction surface between the transparent protective film **10a** and the bonding layer **119** and the junction surface between the transparent protective film **10a** and the metal reflection layer **117**. Accordingly, in the present embodiment, the penetration of the external air or moisture into the junction layer **110** of the semiconductor light-emitting device **1** can be prevented more effectively.

Also, in the semiconductor light-emitting device **1** of the present embodiment, since the edge portion protection film **10b**, which covers the outer edge portion of the bonding pad electrode **120** and exposes a portion of the bonding pad electrode **120**, is formed, further more superior anticorrosion and junction properties can be obtained.

Further, according to the semiconductor light-emitting device **1** of the present embodiment, since the bonding pad electrode **120** having an slope **119c**, which is made gradually thinner toward the outside, formed on the outer circumference **120d** is formed to cover the junction layer **110**, a contact surface area between the outer circumference portion **120d** of the bonding pad electrode **120** and the lower surface of the outer circumference portion **120d** of the bonding pad electrode **120** (in the present embodiment, transparent protection film **10a**) can be sufficiently secured to obtain superior junction, and the penetration of the external air or moisture into the junction layer **110** through a portion between the outer circumference portion **120d** of the bonding pad electrode **120** and the lower surface thereof can be effectively prevented to provide superior anticorrosion property.

Also, in the method of manufacturing a semiconductor light-emitting device **1** according to the present embodiment, the step of manufacturing the p-type electrode **111** includes the steps of: forming the transparent electrode **109** on the upper surface **106c** of the laminated semiconductor layer **20**; forming the hole portion **109a** in the transparent electrode **109**, through which the upper surface **106c** of the laminated semiconductor layer **20** is exposed to the bottom surface **109b**; forming the junction layer **110**, which is made of the material with the property in which the junction resistivity to the laminated semiconductor layer **20** is higher than the junction resistivity to the transparent electrode **109**, on the bottom surface **109b** and the inner wall **109d** of the hole portion **109a**; and forming the bonding pad electrode **120** to cover the junction layer **110**. Therefore, it is possible to manufacture the semiconductor light-emitting device **1** of the present embodiment which is excellent in the junction property of the p-type electrode **111** and light extraction efficiency.

Also, the method of manufacturing a semiconductor light-emitting device **1** according to the present embodiment includes the steps of forming the hole portion **109a** by etching the upper surface **109c** of the transparent electrode **109** exposed from the opening **10d** of the transparent protection film **10a**, and forming the junction layer **110** on the bottom surface **109b** and the inner wall **109d** of the hole portion **109a**. Therefore, the junction layer **110** is formed in contact with the inner wall **109d** of the hole portion **109a** that is exposed from the transparent electrode **109** by forming the hole portion **109a**. By forming the hole portion **109a**, the inner wall **109d** of the hole portion **109a** that is exposed from the transparent electrode **109** has superior adhesion to the junction layer **110** in comparison to the upper surface **109c** of the transparent electrode **109**, and thus according to the manufacturing method of the present embodiment, the p-type electrode **111** having superior adhesion with the junction layer **110** can be

obtained in comparison to the case of forming the junction layer **110** on the upper surface **109c** of the transparent electrode **109**.

Embodiment 2 Semiconductor Light-Emitting Device

FIG. 7 is a view illustrating another example of a semiconductor light-emitting device according to the present invention, and is a schematic enlarged cross-sectional view illustrating a p-type electrode that constitutes the semiconductor light-emitting device. The semiconductor light-emitting device of the present embodiment as illustrated in FIG. 7 has the same configuration as that of the semiconductor light-emitting device **1** as illustrated in FIG. 1 except that the transparent protective film **10a** and the edge portion protection film **10b** are not formed in the present embodiment. The configuration except those is the same as the semiconductor light-emitting device **1** illustrated in FIG. 1. Accordingly, the same reference numerals are given to the same members as those according to Embodiment 1, and the explanation thereof will be omitted.

Also, the p-type electrode **112** that constitutes the semiconductor light-emitting device of the present embodiment can be formed in the same manner as the p-type electrode **111** as illustrated in FIG. 1 except that the transparent protective film **10a** and the edge portion protection film **10b** are not formed in the present embodiment.

Even though the transparent protection film **10a** and the edge portion protection film **10b** are not prepared as in the semiconductor light-emitting device of the present embodiment illustrated in FIG. 7, the p-type electrode **112** includes: the transparent electrode **109** containing the hole portion **109a**, through which the upper surface **106c** of the laminated semiconductor layer **20** is exposed, on the bottom surface **109b**; the junction layer **110** formed on the bottom surface **109b** and the inner wall **109d** of the hole portion **109a**; and the bonding pad electrode **120** formed to cover the junction layer **110**. Also, the junction resistivity between the junction layer **110** and the laminated semiconductor layer **20** is higher than the junction resistivity between the junction layer **110** and the transparent electrode **109**. Therefore, the current from the bonding pad electrode **120** is mainly diffused in the in-plane direction of the transparent **109** from the inner wall **109d** of the hole portion **109a** of the transparent electrode **109** through the junction layer **110**, and is supplied on the upper surface of the laminated semiconductor layer **20**. The amount of the current supplied through the transparent electrode **109** among the current supplied to the laminated semiconductor **20** is larger than the amount of the current directly supplied from the junction layer **110** that contacts the laminated semiconductor layer **20**.

Therefore, even in the semiconductor light-emitting device of the present embodiment, even though the bonding pad electrode **120** does not have transparency and shields a light, it is possible to extremely reduce the ratio of the light, which cannot be extracted to the outside of the semiconductor light-emitting device **1** due to shielding of the bonding pad electrode **120**, to the light emitted from the light-emitting layer **105**. Also, the light extraction efficiency is high, and the light extraction property is good.

Further, even in the semiconductor light-emitting device of the present embodiment, due to the junction layer **110**, it is possible to obtain the sufficiently high junction strength between the bonding pad electrode **120**, and the transparent electrode **109** and the laminated semiconductor layer **20**.

Thus, the semiconductor light-emitting device includes the p-type electrode **111** with the good junction property.

Further, even in the semiconductor light-emitting device of the present embodiment, the bonding pad electrode **120** having the slope **119c**, which is made gradually thinner toward the outside and is formed in the outer circumference portion **120d**, is formed to cover the junction layer **110**, and thus the penetration of the external air or moisture into the junction layer **110** can be effectively prevented, and thus superior anticorrosion property is obtained.

Embodiment 3 Semiconductor Light-Emitting Device

FIG. **8** is a view illustrating another example of a semiconductor light-emitting device according to the present invention, and is a schematic cross-sectional view illustrating a semiconductor light-emitting device according to the present invention. The semiconductor light-emitting device **1a** of the present embodiment as illustrated in FIG. **8** has the same configuration as that of the semiconductor light-emitting device **1** as illustrated in FIG. **1** except that the transparent protective film **10a** is not formed, and as planarly viewed, an upper surface protection film **10** is installed on the entire surface of the upper surface **109c** of the transparent electrode **109** except for the area that exposes the center portion of the bonding pad electrode **120** in the present embodiment. The configuration except those is the same as the semiconductor light-emitting device **1** illustrated in FIG. **1**. Accordingly, the same reference numerals are given to the same members as those according to Embodiment 1, and the explanation thereof will be omitted.

The upper surface protection film **10** may be made of the same material as the transparent protective film **10a** with the same thickness according to the semiconductor light-emitting device **1** as illustrated in FIG. **1**.

In order to manufacture the semiconductor light-emitting device **1a** as illustrated in FIG. **8**, the n-type electrode **108** is formed after the laminated semiconductor layer **20** is formed in the same manner as the semiconductor light-emitting device **1** as illustrated in FIG. **1**.

Then, as described below, the p-type electrode **111a** is manufactured. FIG. **9A** to FIG. **9E** are the views illustrating a step of manufacturing the p-type electrode, and is an enlarged cross-sectional view illustrating only a portion of the area in which the p-type electrode **111a** is manufactured.

As illustrated in FIG. **9A**, in order to manufacture the p-type electrode **111a** of the present embodiment, the transparent electrode **109** is first formed on the p-type semiconductor layer **106** in the same manner as the semiconductor light-emitting device **1** as illustrated in FIG. **1**.

Then, as illustrated in FIG. **9A**, a resist **21** is coated on the transparent protective film **10a** to be dried, and a reverse-tapered mask **23** illustrated in FIG. **9B**, which has an opening **23a** that is in the form of an inner wall of which the cross-sectional area is gradually widened toward the bottom surface, is formed on the upper surface **109c** of the transparent electrode **109** in the same manner as the semiconductor light-emitting device **1** as illustrated in FIG. **1**.

Then, a hole portion **109a** is formed in the transparent electrode **109**, as illustrated in FIG. **9C**, by etching the transparent electrode **109** that is exposed from the opening **23a** of the mask **23** as illustrated in FIG. **9B** in the same manner as the semiconductor light-emitting device **1** as illustrated in FIG. **1**.

Then, as illustrated in FIG. **9D**, in the same manner as the semiconductor light-emitting device **1** as illustrated in FIG. **1**,

a junction layer **110**, a metal reflection layer **117**, and a bonding layer **119** are formed. Thereafter, in the same manner as the semiconductor light-emitting device **1** as illustrated in FIG. **1**, the mask **23** is peeled off. Accordingly, as illustrated in FIG. **9E**, a bonding pad electrode **120** including the metal reflection layer **117** and the bonding layer **119** is formed. Even in the present embodiment, in the same manner as the semiconductor light-emitting device **1** as illustrated in FIG. **1**, slopes **110c**, **117c**, and **119c**, which are made gradually thinner toward the outside, are formed on the outer circumference portions of the junction layer **110**, the metal reflection layer **117**, and the bonding layer **119**.

Next, using a known method in the related art, as seen from a plane, the upper surface protection film **10** is formed on the entire surface of the upper surface **109c** of the transparent electrode **109**, except for the area that exposes the center portion of the bonding pad electrode **120**. By doing this, a semiconductor light-emitting device **1a** having the p-type electrode **111a** as illustrated in FIG. **8** is formed.

Even in the semiconductor light-emitting device **1a** of the present embodiment, in the same manner as the semiconductor light-emitting device **1** as illustrated in FIG. **1**, the light extraction efficiency is high, the light extraction property is good, and the junction and anticorrosion properties are good.

Also, according to the semiconductor light-emitting device **1a** of the present embodiment, as seen from a plane, since the upper surface protection film **10** is formed on the entire surface of the upper surface **109c** of the transparent electrode **109**, except for the area that exposes the center portion of the bonding pad electrode **120**, further excellent anticorrosion and junction properties can be obtained.

Embodiment 4 Lamp

FIG. **10** is a schematic cross-sectional view illustrating an example of a lamp according to the present invention. As illustrated in FIG. **10**, the lamp **3** of the present embodiment is in the form of a shell, and the semiconductor light-emitting device **1** according to the present invention as illustrated in FIG. **1** is built therein as the semiconductor light-emitting device. In this case, the lamp **3**, for example, is configured by combining the semiconductor light-emitting device **1** and phosphors, and has a configuration that is known to those of ordinary skill in the art which is configured by a means that is known to those of ordinary skill in the art. Also, by combining the semiconductor light-emitting device **1** with phosphors, it is known that the light-emitting color can be changed, and it is possible to adopt such technology even in the lamp according to an embodiment of the present invention without any limitation.

As illustrated in FIG. **10**, the lamp **3** of the present embodiment includes one frame **31** which is bonded by a wire **33** to the bonding pad electrode **120** of the p-type electrode **111** of the semiconductor light-emitting device **1**, the other frame **32** which is bonded by a wire **34** to the n-type electrode **108** (bonding pad) of the semiconductor light-emitting device **1**, and a mold **35** made of transparent resin that is formed around the neighborhood of the semiconductor light-emitting device **1**.

Also, the lamp **3** according to the present embodiment is provided with the semiconductor light-emitting device **1** as illustrated in FIG. **1** which is excellent in the light extraction efficiency and has the electrode having superior junction and anticorrosion properties as a semiconductor light-emitting device. Therefore, the lamp **3** with superior anticorrosion property and light emission efficiency can be manufactured with good yield.

The lamp 3 according to the present embodiment may be used in any type for any purpose, such as a shell type for general use, a side view type for a portable backlight, a top view type for use in a displayer, and the like.

Also, since the lamp 3 manufactured from the semiconductor light-emitting device according to the present invention has superior effect as described above, an electronic appliance incorporated with the lamp manufactured by this technique, such as a backlight, portable phone, display, various kinds of panels, computer, game machine, illumination, or the like, and a mechanical device such as a vehicle incorporated with the electronic appliance can provide high reliability as the product in use. Particularly, in an appliance that drives a battery, such as a backlight, portable phone, display, game machine, illumination, or the like, a product provided with a light-emitting device having high reliability can be preferably provided.

Hereinafter, the present invention will be described in detail based on examples. However, the present invention is not limited to such examples.

Example 1

Production of Semiconductor Light-Emitting Device

A semiconductor light-emitting device made of gallium nitride-based compound semiconductor as illustrated FIG. 1 to FIG. 3, in which the p-type electrode 111 (the transparent electrode 109, and the junction layer 110, and the bonding pad electrode 120 (the metal reflection layer 117, the barrier layer, and the bonding layer 119)) and the n-type electrode 108 had the configurations shown in Tables 1 and 2, was manufactured as follows.

TABLE 1

	P-Type Electrode										N-Type Electrode
	Transparent Electrode					Bonding Pad Electrode					
	Material	Thickness (nm)	Material	Thickness (nm)	Material	Thickness (nm)	Material	Thickness (nm)	Material	Thickness (nm)	
Example 1	IZO	250	Cr	10	Pt	100	—	—	Au	1100	Ti/Pt/Au
Example 2	IZO	250	Cr	10	Pt	100	—	—	Au	1100	Same as Configuration of Junction Layer and Bonding Pad Electrode of P-Type Electrode
Example 3	ITO	200	Cr	2	Rh	200	Ti	80	Au	200	Same as above
Example 4	IZO	200	Cr	2	Al	200	Ti	80	Au	200	Same as above
Example 5	IZO	200	Cr	2	Ag	200	Ti	80	Au	200	Same as above
Example 6	IZO	200	Cr	2	Rh	200	Ti	80	Au	200	Same as above
Example 7	IZO	200	Ni	2	Al	200	Ti	80	Au	200	Same as above
Example 8	IZO	200	Co	2	Al	200	Ti	80	Au	200	Same as above
Example 9	IZO	200	Cr	1	Al	200	Ti	80	Au	200	Same as above
Example 10	IZO	200	Cr	5	Al	200	Ti	80	Au	200	Same as above

TABLE 2

	P-Type Electrode										N-Type Electrode
	Transparent Electrode					Bonding Pad Electrode					
	Material	Thickness (nm)	Material	Thickness (nm)	Material	Thickness (nm)	Material	Thickness (nm)	Material	Thickness (nm)	
Example 11	IZO	250	Cr	40	Pt	100	—	—	Au	1100	Same as above
Example 12	IZO	200	Ti	10	Rh	100	—	—	Au	1100	Same as above
Example 13	IZO	200	Ti	10	Pt	100	—	—	Au	1100	Same as above
Example 14	IZO	200	Ti	10	Ir	100	—	—	Au	1100	Same as above
Example 15	ITO	200	Ti	2	Pt	200	—	—	Au	550	Same as above
Example 16	ITO	200	Ti	2	Ir	200	—	—	Au	550	Same as above
Example 17	ITO	200	Ni	40	—	—	—	—	Au	1100	Same as above
Example 18	ITO	200	Ni	40	Pt	200	—	—	Au	550	Same as above
Comparative Example 1	IZO	250	Cr	10	Pt	200	—	—	Au	1100	Ti/Pt/Au

[Formation of Laminated Semiconductor Layer]

First, a ground layer **103** made of undoped GaN with a thickness of 8 μm was formed on a substrate **101** made of sapphire via a buffer layer **102** made of AlN. Next, an n-contact layer **104a** made of Si-doped n-type GaN with a thickness of 2 μm and an n-type clad layer **104b** made of n-type $\text{In}_{0.1}\text{Ga}_{0.9}\text{N}$ with a thickness of 250 nm were formed. Thereafter, a Si-doped GaN barrier layer with a thickness of 16 nm and an $\text{In}_{0.2}\text{Ga}_{0.8}\text{N}$ well layer with a thickness of 2.5 nm were laminated five times, and lastly, a light-emitting layer **105** of a multiple quantum well structure, in which the barrier layer was installed, was formed. Further, a p-clad layer **106a** made of Mg-doped p-type $\text{Al}_{0.07}\text{Ga}_{0.93}\text{N}$ with a thickness of 10 nm and a p-contact layer **106b** made of Mg-doped p-type GaN with a thickness of 150 nm were formed in order.

At that time, the formation of the laminated semiconductor layer **20** was performed by a MOCVD method on well-known typical conditions in the corresponding technical field.

[Formation of Electrode]

After the laminated semiconductor layer **20** was formed as described above, a portion of the n-contact layer **104a** was exposed by patterning the laminated semiconductor layer **20** by a photolithography method and etching a portion of the laminated semiconductor layer **20** of a predetermined area. Next, an n-type electrode **108** made of Ti/Pt/Au in order was formed on the exposed surface **104c** of the n-contact layer **104a** by a sputtering method.

Thereafter, as described below, a p-type electrode **111** was formed. First, a transparent electrode **109** made of IZO with a thickness of 250 nm was formed on the p-type GaN contact layer **106b**, and a transparent protective film **10a** made of SiO_2 with a thickness of 100 nm was formed on the transparent electrode **109**.

Next, using AZ5200NJ (product name: product of AZ Electronic Materials) as an image reversion type photoresist, a reverse-tapered mask **23** having an opening **23a** that is in the form of an inner wall of which the cross-sectional area was gradually widened toward the bottom surface, was formed on the upper surface of the transparent electrode **109** on which the transparent protective film **10a** was formed.

Then, the transparent protective film **10a** that is exposed from the opening **23a** of the mask **23** was removed by using RIE (Reactive Ion Etching) in a direction vertical to the upper surface **109c** of the transparent electrode **109**, so as to form an opening **10d** and to expose the upper surface **109c** of the transparent electrode **109** from the opening **10d**.

Next, a hole portion **109a** was formed by dry-etching the transparent electrode **109** that is exposed from the opening **23a** of the mask **23**. Thereafter, the heat-treatment was performed at temperature of 650° C. in nitrogen atmosphere to crystallize the IZO layer in an amorphous state.

Next, by the sputtering method, the junction layer **110** made of Cr was formed with a maximum thickness of 10 nm to cover the bottom surface **109b** and the inner wall **109d** of the hole portion **109a** of the transparent electrode **109**. Next, by the sputtering method, a metal reflection layer **117** made of

Pt with a maximum thickness of 100 nm which covers the junction layer **110** and has an slope **117c**, which is made gradually thinner toward the outside, formed on the outer circumference thereof was formed. Then, by the sputtering method, the bonding layer **119** made of Au with a maximum thickness of 1100 nm, of which the shape of the outer circumference was formed along the inner wall shape of the opening **23a** of the mask **23**, which covered the metal reflection layer **117**, and had an slope **119c**, which was made gradually thinner toward the outside, formed on the outer circumference portion **120d**, was formed. Accordingly, the bonding pad electrode **120** including the metal reflection layer **117** and the bonding layer **119** was formed.

Thereafter, by soaking the resist in a resist peel-off solution, the mask **23** was peeled off. Next, as planarly viewed, the edge portion protection film **10b**, which was made of SiO_2 with a width of 5 μm and with a maximum thickness of 250 nm, covered the outer edge portion of the bonding pad electrode **120** through a portion that is a juncture between the outer edge portion (contour-line) of the bonding pad electrode **120** and the transparent protective film **10a**, and was roughly in the form of a donut that exposes the center portion of the bonding pad electrode **120**. By doing this, a semiconductor light-emitting device **1** of Example 1 having the p-type electrode **111** as illustrated in FIG. 1 to FIG. 3 was obtained.

Examples 2-18

Semiconductor light-emitting devices of Examples 2-18, which were the same as the semiconductor light-emitting device **1** of Example 1 except that the p-type electrode (the transparent electrode, the junction layer, and the bonding pad electrode (the metal reflection layer, the barrier layer, and the bonding layer)) and the n-type electrode were configured as shown in Tables 1 and 2, were manufactured.

Comparative Example 1

A semiconductor light-emitting device illustrated in FIG. 11 was manufactured, which was the same as the semiconductor light-emitting device **1** of Example 1, except that the edge portion protection film **10b** was not formed; the hole portion **109a** is not formed in the transparent electrode **109**; and the side surfaces of the metal reflection layer **217** and the bonding layer **219**, which constituted the junction layer **210** and the bonding pad electrode **220**, were formed almost vertical to the upper surface **109c** of the transparent electrode **109**.

<Evaluation of Semiconductor Light-Emitting Device>

With respect to the semiconductor light-emitting devices of Examples 1-18 and Comparative Example 1, a forward voltage was measured through conduction by a probe with an applied current value of 20 mA. The results are shown in Table 3.

As shown in Table 3, the forward voltage in Examples 1-18 was 3.0 V or 3.1 V, and the forward voltage in Comparative Example 1 was 3.0 V.

TABLE 3

	Forward Voltage (V)	Light Emission Output (mW)	Reflection Ratio of Bonding Pad Electrode (%)	Number of Bonding Inferiorities (among 100,000 chips)	Number of Inferiorities in Test at High Temperature and Humidity (among 100 chips)	Anticorrosion Test
Example 1	3.0	20	80	0	2	Good
Example 2	3.0	21	80	2	5	Good

TABLE 3-continued

	Forward Voltage (V)	Light Emission Output (mW)	Reflection Ratio of Bonding Pad Electrode (%)	Number of Bonding Inferiorities (among 100,000 chips)	Number of Inferiorities in Test at High Temperature and Humidity (among 100 chips)	Anticorrosion Test
Example 3	3.0	22	85	0	0	Good
Example 4	3.1	22	85	1	5	Good
Example 5	3.1	22.5	85	2	5	Good
Example 6	3.1	22	85	0	0	Good
Example 7	3.0	22	85	2	6	Good
Example 8	3.0	22	85	3	7	Good
Example 9	3.0	23	90	5	10	Good
Example 10	3.0	21	75	0	2	Good
Example 11	3.0	20.5	70	0	0	Good
Example 12	3.0	20.5	70	0	0	Good
Example 13	3.0	20.5	70	0	0	Good
Example 14	3.0	20.5	70	0	0	Good
Example 15	3.0	21	75	0	0	Good
Example 16	3.0	21	75	0	0	Good
Example 17	3.0	19	55	0	0	Good
Example 18	3.0	20.5	70	0	0	Good
Comparative Example 1	3.0	21	80	50	65	Bad

Thereafter, the semiconductor light-emitting devices of Examples 1-18 and Comparative Example 1 were mounted in the TO-18 can package, and the light emission output at the applied current of 20 mA was measured by a tester. The results of measurement are shown in Table 3.

As shown in Table 3, the light emission outputs of Examples 1-18 were within the range of 19.5 to 23 mW, and the light emission output of Comparative Example 1 was 21 mW.

The light emission distributions on the light-emitting surfaces were examined in Example 1-18 and Comparative Example 1. As a result, the uniform light emissions were confirmed in Example 1-18. In contrast, in Comparative Example 1, the light emission was confirmed only on the light-emitting layer that was positioned in the vicinity of the p-type electrode.

Further, in the Examples 1-18 and the Comparative Example 1, the reflection ratio of the produced bonding pad electrode was measured. The measurement of the reflection ratio was performed in a wavelength area of 460 nm using a spectrophotometer with respect to the same thin film as the bonding pad electrode formed using a glass dummy substrate put into the chamber during the formation of the bonding pad electrode. The results of measurement are shown in Table 3.

Also, bonding test was performed with respect to the semiconductor light-emitting devices (chips) of Examples 1-18 and Comparative Example 1. The results are shown in Table 3.

As illustrated in Table 3, in Examples 1, 3, 6, and 10-18, there was no chip in which the pad was peeled off (the number of bonding inferiorities) among 100,000 chips. Also, in other Examples, the number of bonding inferiorities was 5 or less, which was very small. In contrast, in Comparative Example 1, the number of bonding inferiorities was 50 among 100,000 chips.

<Chip Test in High Temperature and Humidity Conditions>

The semiconductor light-emitting devices (chip) of Examples 1-18 and Comparative Example 1 were put into high-temperature high-humidity tester (ISUZU Seisakusho, Co., Ltd., μ -SERIES), and a light emission test (the amount of

current passing through the chip was 5 mA, for 2000 hours) was made with respect to 100 chips under the environment of a temperature of 85° C. and relative humidity of 85RH %. The test results are shown in Table 3.

As shown in Table 3, the number of inferiorities was 0 in Examples 3, 6, and 11-18. Also, in other Examples, the number of inferiorities was 10 or less, which is quite small. In contrast, in Comparative Example 1, the number of inferiorities was 65.

<Anticorrosion Test>

In a state where the semiconductor light-emitting device emitted light under the conditions of the applied current value of 20 mA and the forward voltage of 3.0 V to 3.1 V, the semiconductor light-emitting devices in Examples 1-18 and Comparative Example 1 were sunk under water in a water tank.

In Examples 1-18, the semiconductor light-emitting devices were kept in this state for 10 minutes, was pulled out of the water, and then the light emission characteristic was measured again. As a result, in Examples 1-18, the light emission characteristics after the semiconductor light-emitting device was sunk under water in the water tank was almost not changed in comparison to that measured before the semiconductor light-emitting device was sunk under water.

In contrast, in Comparative Example 1, the light emission was kept only for several seconds in a state where the semiconductor light-emitting device is sunk under water in the water tank, and no further light was emitted thereafter.

INDUSTRIAL APPLICABILITY

The present invention relates to a semiconductor light-emitting device, a manufacturing method thereof, and a lamp, and can be used in the industry that manufactures and uses the semiconductor light-emitting device having the electrode improved in junction and anticorrosion properties, the manufacturing method thereof, and the lamp.

REFERENCE SIGNS LIST

- 1, 1a: Semiconductor Light-Emitting Device
- 3: Lamp

10a: Transparent Protection Film
10b: Edge Portion Protection Film
10c: End Portion
10d: Opening
20: Laminated Semiconductor Layer
21: Resist
22: Soluble Resist
23, 25: Mask
23a: Opening
31, 32: Frame
33, 34: Wire
35: Mold
101: Substrate
102: Buffer Layer
103: Ground Layer
104: N-Type Semiconductor Layer
104a: N-Contact Layer
104b: N-Clad Layer
104c: Exposed Surface
105: Light-Emitting Layer
105a: Barrier Layer
105b: Well Layer
106: P-Type Semiconductor Layer
106a: P-Clad Layer
106b: P-Contact Layer
106c: Upper Surface
108: N-Type Electrode (Second Electrode)
109: Transparent Electrode
109a: Hole Portion
109b: Bottom Surface
109c: Upper Surface
109d: Inner wall
110: Junction Layer
110c: Slope
110d: Outer Circumference Portion
111, 112: P-Type Electrode (First Electrode)
117: Metal Reflection Layer
117c: Slope
119: Bonding Layer
119c: Slope
120: Bonding Pad Electrode
120d: Outer Circumference Portion

The invention claimed is:

1. A semiconductor light-emitting device comprising:
 a substrate;
 a laminated semiconductor layer containing a light-emitting layer, which is formed on the substrate;
 a first electrode formed on the upper surface of the laminated semiconductor layer; and
 a second electrode formed on an exposed surface that is formed by partially cutting the laminated semiconductor layer, wherein
 the first electrode includes a transparent electrode containing a hole portion through which the upper surface of the laminated semiconductor layer is exposed, a junction layer formed on a bottom surface and an inner wall of the hole portion, and a bonding pad electrode formed directly over the junction layer wherein the bonding pad electrode completely covers the junction layer,
 a junction resistivity between the laminated semiconductor layer and the junction layer is higher than a junction resistivity between the transparent electrode and the junction layer;
 the bonding pad electrode is comprised of a metal reflection layer formed directly over the junction layer wherein the metal reflection layer completely covers the junction layer, and a bonding layer formed directly over

the metal reflection layer wherein the bonding layer completely covers the metal reflection layer, and the metal reflection layer is made of any one selected from the group consisting of Ag, Al, Ru, Rh, Pd, Os, Ir, Pt, and Ti or an alloy comprising any one of these metals.

2. The semiconductor light-emitting device according to claim **1**, wherein the junction layer is made of at least one kind of element selected from the group consisting of Al, Ti, V, Cr, Mn, Co, Zn, Ge, Zr, Nb, Mo, Ru, Hf, Ta, W, Re, Rh, Ir, and Ni, and is a thin film whose maximum thickness is within a range from 10 Å or more to 400 Å or less.

3. The semiconductor light-emitting device according to claim **1**, wherein the bonding layer is made of Au, Al, or an alloy comprising any one of these metals.

4. The semiconductor light-emitting device according to claim **1**, wherein the transparent electrode is made of a transparent conductive material selected from the group consisting of zinc sulfide, chromium sulfide, and a conductive oxide comprising any one kind selected from the group consisting of In, Zn, Al, Ga, Ti, Bi, Mg, W, Ce, Sn, and Ni.

5. The semiconductor light-emitting device according to claim **1**, wherein the laminated semiconductor layer is mainly comprised of a gallium nitride semiconductor.

6. The semiconductor light-emitting device according to claim **1**, wherein the laminated semiconductor layer is formed by laminating in order an n-type semiconductor layer, the light-emitting layer, and a p-type semiconductor layer on the substrate, and the light-emitting layer has a multiple quantum well structure.

7. A lamp comprising:

the semiconductor light-emitting device according to claim **1**;

a first frame on which the semiconductor light-emitting device is arranged and which is wire-bonded with the first electrode of the semiconductor light-emitting device;

a second frame which is wire-bonded with the second electrode of the semiconductor light-emitting device; and

a mold formed around the semiconductor light-emitting device.

8. A method of manufacturing a semiconductor light-emitting device which comprises a substrate; a laminated semiconductor layer containing a light-emitting layer, which is formed on the substrate; a first electrode formed on the upper surface of the laminated semiconductor layer; and a second electrode formed on an exposed surface that is formed by partially cutting the laminated semiconductor layer,

the method comprising a first electrode formation step which comprises the steps of:

forming a transparent electrode on the upper surface of the laminated semiconductor layer;

forming a hole portion of the transparent electrode, through which the upper surface of the laminated semiconductor layer is exposed;

forming a junction layer on a bottom surface and an inner wall of the hole portion; and

forming a bonding pad electrode directly over the junction layer wherein the bonding pad electrode completely covers the junction layer, wherein

the bonding pad electrode is comprised of a metal reflection layer formed directly over the junction layer wherein the metal reflection layer completely covers the junction layer, and a bonding layer formed directly over the metal reflection layer wherein the bonding layer completely covers the metal reflection layer, and

the metal reflection layer is made of any one selected from the group consisting of Ag, Al, Ru, Rh, Pd, Os, Ir, Pt, and Ti or an alloy comprising any one of these metals.

9. An electronic appliance incorporated with the lamp according to claim 7. 5

10. A mechanical device incorporated with the electronic appliance according to claim 9.

11. The semiconductor light-emitting device according to claim 1, wherein the bonding pad electrode is formed directly over the junction layer wherein the bonding pad electrode completely covers the junction layer and has a slope which is made gradually thinner toward the outside. 10

12. The semiconductor light-emitting device according to claim 1, further comprising an edge portion protection film formed to cover the bonding pad electrode. 15

13. The semiconductor light-emitting device according to claim 1, wherein the junction layer is in direct contact with the bottom surface and the inner wall of the hole portion.

14. The semiconductor light-emitting device according to claim 1, wherein the junction layer is in interfacial contact with the entire upper surface of the laminated semiconductor layer that is exposed through the hole portion. 20

* * * * *