

May 9, 1933.

L. DAVIDSON

1,908,125

BOILER

Filed July 20, 1931

3 Sheets-Sheet 1

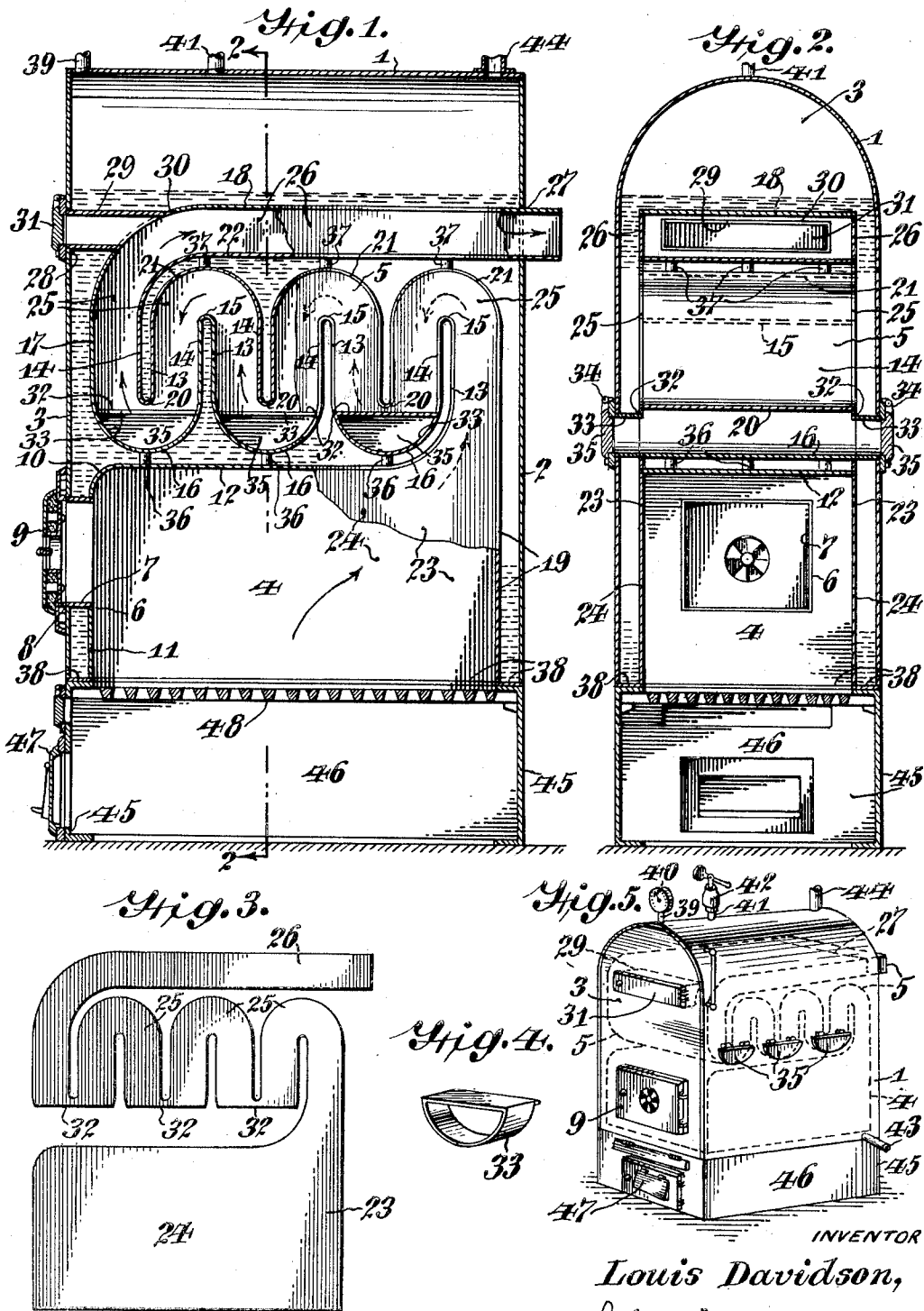

INVENTOR

Louis Davidson,
John D. Myers
Attorney

May 9, 1933.

L. DAVIDSON

1,908,125

BOILER

Filed July 20, 1931

3 Sheets—Sheet 2

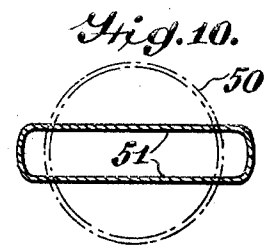
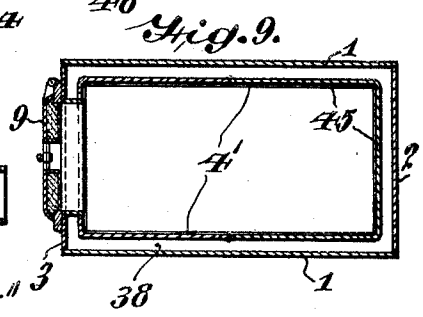
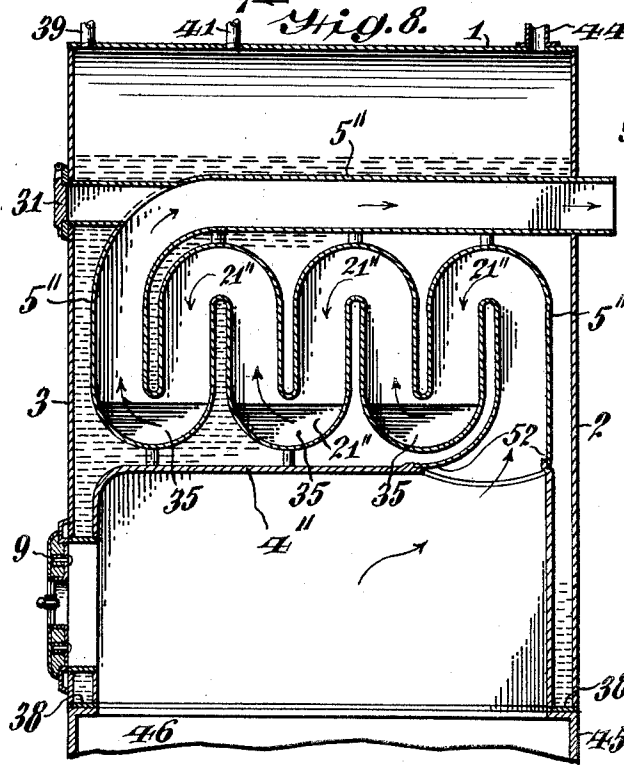
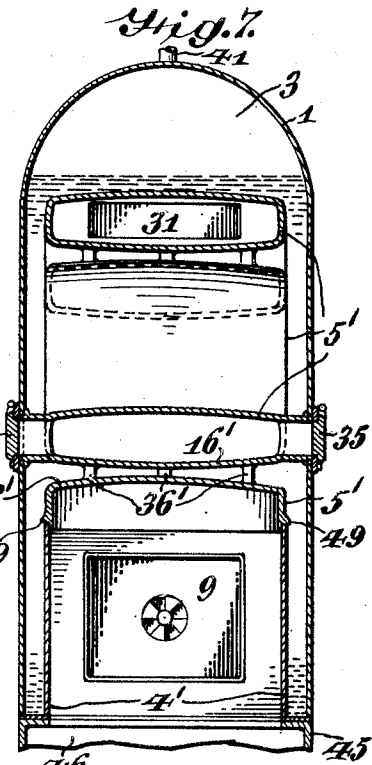
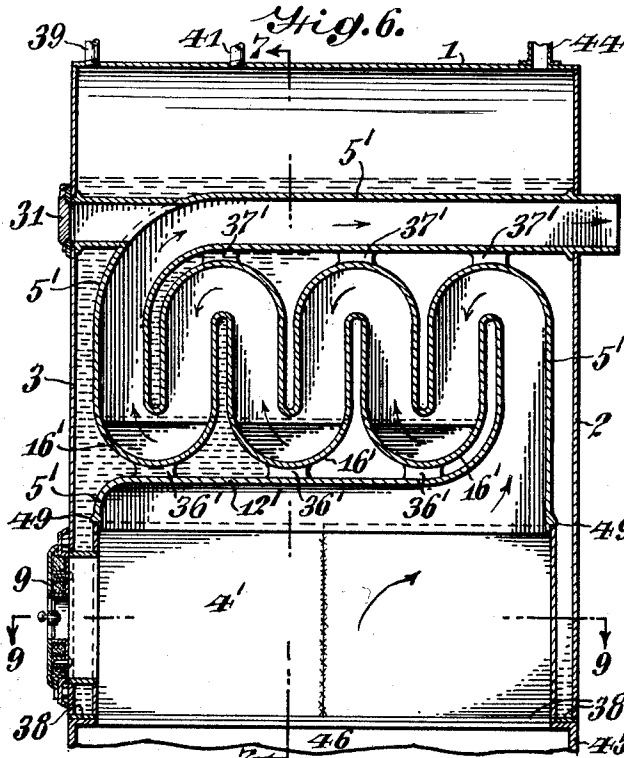

INVENTOR
Louis Davidson,
John Dwyers
Attorneys

May 9, 1933.

L. DAVIDSON

1,908,125

BOILER

Filed July 20, 1931

3 Sheets-Sheet 3

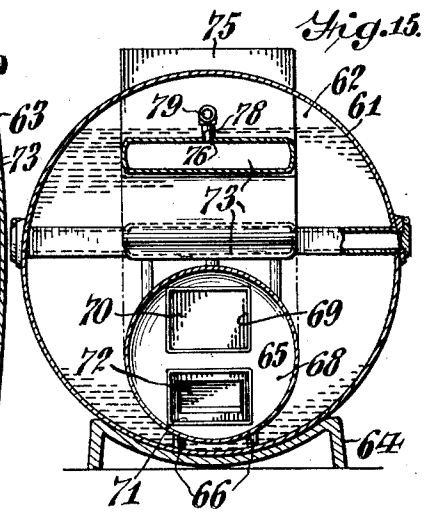
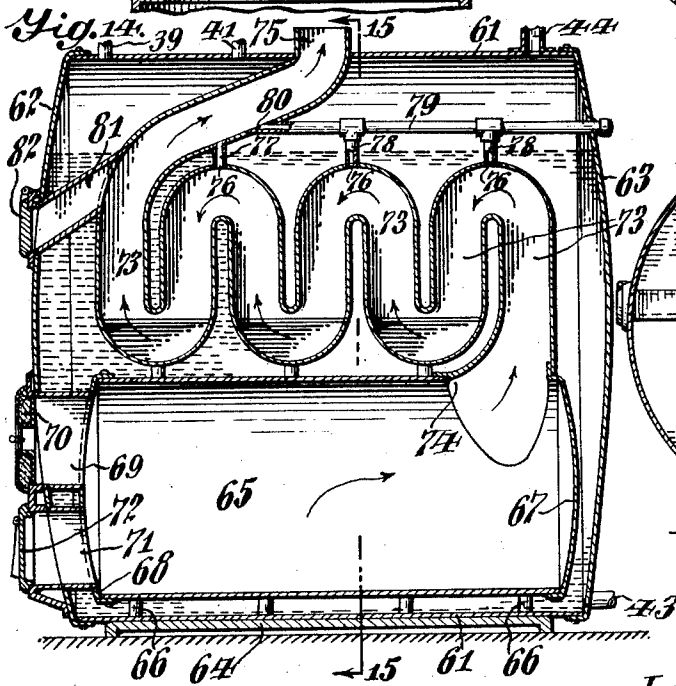
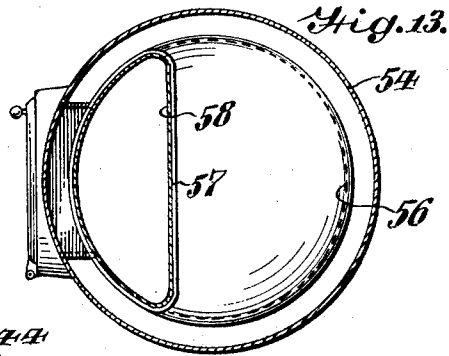
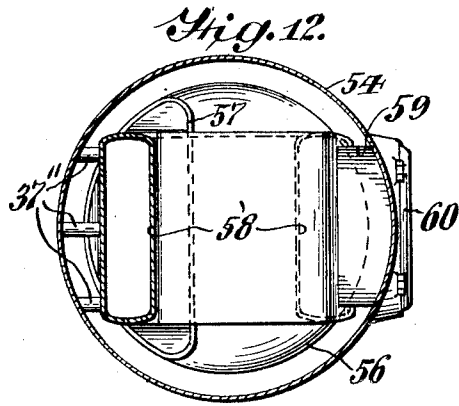
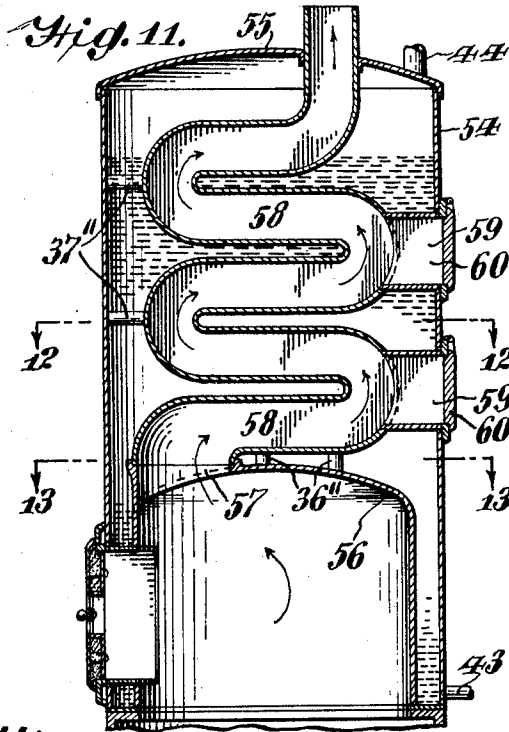

INVENTOR

Louis Davidson,

John W. Myers
Attorney

UNITED STATES PATENT OFFICE

LOUIS DAVIDSON, OF PHILADELPHIA, PENNSYLVANIA, ASSIGNOR TO MINA KAUFFMAN, OF PHILADELPHIA, PENNSYLVANIA

BOILER

Application filed July 20, 1931. Serial No. 551,890.

My invention relates to boilers which are used in generating steam or heating water, and relates particularly to that type of boilers which is ordinarily employed for heating purposes.

Boilers of this type are commonly constructed from castings, and, as is well known, castings are usually heavy and do not readily adapt themselves to the constructions which are some times desirable from the standpoint of economy and efficiency in heating apparatus. In particular, my invention has to do with the combustion chamber of a boiler, and I have found that by properly designing the combustion chamber, both the fire box and the flue leading therefrom may be made from sheet metal, thus reducing materially both the cost of manufacture and the weight of the boiler, without substantially reducing the strength.

It is one of the objects of my invention, therefore, to effect economy in the cost of manufacturing such boilers, and to decrease their weight. A further object of my invention is to simplify the entire boiler construction, particularly the construction and arrangement of the combustion chamber. It is also an object of my invention to improve upon the construction of the flue leading from the fire box outwardly through the fluid chamber. This simplification I bring about by so constructing the flue that it is substantially in the form of a flattened tube reversely bent upon itself to produce a tortuous passage for the gases of combustion, such passage being comparatively free from obstructions to the flue gases and providing an extensive heating surface for the water in contact therewith.

Without mentioning further objects of my invention at this point, additional objects will be apparent from the detailed description which follows. In order that my invention may be readily understood and its practical advantages fully appreciated, reference should be made to the accompanying drawings wherein I have illustrated various modifications in which my invention may be embodied.

In the drawings:

Fig. 1 is a vertical longitudinal view of a boiler in which one form of my invention is embodied;

Fig. 2 is a transverse sectional view taken on the line 2—2 of Fig. 1;

Fig. 3 is a vertical side view of one of the end plates for the combustion chamber of the boiler shown in Figs. 1 and 2;

Fig. 4 is a view of the collar inserted between the outer casing of the boiler and the flue to form a flue cleaning outlet.

Fig. 5 is an assembly view of the boiler shown in section in Figs. 1 and 2;

Fig. 6 is a vertical longitudinal view of a modified form of my invention showing the manner in which the combustion chamber may be made of castings;

Fig. 7 is a transverse sectional view taken on the line 7—7 of Fig. 6;

Fig. 8 is a vertical longitudinal view of a further modification of my invention in which the fire box is made of castings and the flue is made of sheet metal;

Fig. 9 is a longitudinal sectional view taken on the line 9—9 of Fig. 6;

Fig. 10 is a detailed view showing the manner in which the flue may be made from metal tubing;

Fig. 11 is a vertical view of an upright cylindrical boiler in which my invention is embodied;

Fig. 12 is a transverse sectional view taken on the line 12—12 of Fig. 11;

Fig. 13 is a transverse sectional view taken on the line 13—13 of Fig. 11;

Fig. 14 is a vertical longitudinal view of a still further modification in which my invention is embodied; and

Fig. 15 is a transverse sectional view taken on the line 15—15 of Fig. 14.

In the boiler to which I apply my invention I provide an outer casing made of sheet metal, the side and top walls of which are formed from a single continuous member 1 bent into substantially the shape of an inverted U. End walls 2 and 3, likewise made of sheet metal, are suitably secured to the member 1 by welding or otherwise.

Within the outer casing of the boiler I

provide a combustion chamber comprising a fire box 4 and a flue 5 leading upwardly therefrom. The front wall of the fire box 4 is provided with a suitable opening at 6 within which a rim 7 is secured to thus provide an opening through which fuel may be supplied to the fire box. The outer end of the rim 7 is suitably secured within an opening 8 of the front wall 3 of the outer casing of the boiler, and the fuel opening may be closed by means of a door 9.

The combustion chamber disclosed in Figs. 1 to 5 of the drawings comprises essentially three sheet metal members. One of these members is bent at right angles to form the front wall of the fire box and the upper wall thereof, and is then reversely bent on itself a number of times to form the bottom wall of the flue, after which it continues as the upper wall of the flue outlet. As shown in Fig. 1 of the drawings, this member includes the vertical portion 11 forming the front wall of the fire box, and bends rearwardly at 10 to form the upper wall 12 thereof. This sheet metal member then turns upwardly, as at 13, and is reversely bent upon itself a number of times, as at 14, to form the lower wall of a tortuous passageway for the flue gases. The bend between the vertical portions 13 and 14 is preferably curved, as shown at 15, and the walls 13 and 14 are spaced from each other to provide a water chamber therebetween. The number of the reverse bends in the lower wall of the flue will depend upon the size of the boiler. The construction will be such, however, that after a sufficient number of reverse bends have been provided the sheet metal member forming the front and top walls of the fire box and the lower wall of the flue turns upwardly, as at 17, in spaced relation to the front wall 3 of the outer casing of the boiler, whereupon this member turns rearwardly to form the upper wall of the flue outlet as shown at 18.

As I have embodied my invention in the boiler shown in Figs. 1 to 5, I preferably construct the rear wall of the fire box, the upper wall of the flue, and the lower wall of the flue outlet from one continuous piece of sheet metal. This sheet metal member comprises the vertical back wall of the fire box 19 extending upwardly in spaced relation to the wall 2 of the outer casing, whereupon it is reversely bent upon itself a suitable number of times to form, with the lower reversely bent wall and the side walls hereinafter described, a tortuous passageway for flue gases. The member forming the rear wall 19 of the fire box is curved as indicated at 21 and thence reversely bent upon itself as indicated at 20. It will be observed that this construction provides a series of projections and depressions in both the upper and lower flue walls, the projec-

tions of one being arranged within the depressions of the other to thus form a continuous, unobstructed passageway. It will be observed further that the construction is such that all bends in the passageway are of curvilinear formation, a construction which materially assists the passage of the flue gases therethrough.

After being reversely bent upon itself a sufficient number of times to form the upper wall of the main portion of the flue 5, the sheet metal member is bent rearwardly as at 22 in parallel and spaced relation with respect to the upper wall 18 to form the flue outlet.

The side walls of the combustion chamber are preferably formed from a punched sheet metal member 23 as shown in Figs. 2 and 3 of the drawings. This sheet metal member is so formed as to provide a side wall 24 for the fire box 4, a side wall 25 for the flue 5 and a side wall 26 for the flue outlet. It will be understood that two of the members 23 are provided, one for each side wall of the combustion chamber, and that these side walls may be secured in position with respect to the two sheet metal members forming the front, rear and top walls of the fire box and the top and bottom walls of the flue by welding or otherwise as may be desired.

The flue outlet extends through a suitable opening 27 in the rear wall 2 of the outer casing of the furnace. Opposite the opening 27 an opening 28 may be provided in the front wall 3 of the outer casing, and in the opening 28 the forward end of a flattened tube 29 may be secured and may be connected to the flue outlet as at 30 to provide means whereby the flue outlet may be cleaned. A closure 31 of any suitable form may be provided for this cleaning outlet.

As shown in Fig. 3 of the drawings the lower ends of the side wall 25 for the flue 5 are cut away as at 32 to receive a substantially D-shaped collar 33 secured to the side wall 25 and inserted in an opening in the wall of the outer casing 1, thus providing an opening from the exterior of the boiler whereby the lower reverse bends of the flue may be cleaned. It is to be understood that these cleaning openings are provided on both sides of the furnace for each of the lower bends of the flue. These openings may be closed by covers 35 hinged as shown at 34, or by some other suitable means.

In order that the flue proper may be supported in position I provide a number of metallic stay rods or blocks 36 welded or otherwise secured in place between the upper wall 12 of the fire box and the lower bends of the flue. Similar stay rods 37 are welded or otherwise secured in place between the upper bends of the flue proper and the lower wall 22 of the flue outlet.

A strip of sheet metal 38 is welded or

otherwise secured around the bottom of the walls of the outer casing and the bottom of the side walls of the fire box to close the intervening water chamber.

5 A nipple 39 is secured in the top of the outer casing, preferably near the front thereof, for the attachment of a suitable gauge 40, and a similar nipple 41 is provided in order that a safety valve 42 may be attached
10 to the boiler. An inlet for the fluid chamber is provided at 43 and a suitable outlet may be provided as at 44.

The boiler heretofore described may be provided with a base 45 providing an ash pit 46 having an opening 47 through which
15 ashes may be removed. In case the fuel used with my furnace is wood or coal any desired arrangement of grate bars, as indicated at 48, may be provided. It will be
20 understood, however, that other kinds of fuel, such as oil or gas, may be used if desired.

In the modification of my invention illustrated in Figs. 6 and 7 of the drawings,
25 the fire box 4' is shown as made from sheet metal, although it may be made from castings. Preferably the fire box 4' may be made in two substantially U-shaped sections, and the open ends of the U-shaped
30 sections may be welded or brazed together. In constructing the fire box in this manner it will be observed that the upper wall is formed by a part of the casting of the flue 5'. The form and arrangement of the
35 flue 5' do not differ essentially from the form and arrangement of the flue heretofore described in connection with the construction shown in Figs. 1 to 5. In the process of casting, connecting portions 36' are provided for supporting the lower bends 16'
40 on the upper wall 12' of the fire box, and connecting portions 37' are likewise provided for supporting the flue outlet upon the upper bends 21' of the flue proper.

45 In this modification, as in the construction shown in Figs. 1 to 5, it will be observed that the flue is substantially in the form of a flattened tube reversed upon itself with curved bends, thus providing substantially
50 parallel, unobstructed passages for the flue gases. The flue casting is provided with a shoulder 49 around its bottom edge for supporting it upon the upper edge of the fire box, and the joint thus formed may be sealed
55 in any suitable manner.

In the modification of my invention shown in Fig. 8 I have disclosed the fire box 4''
60 formed of a single, integral casting, and the flue leading therefrom is made from flattened metal tubing. As shown in dotted lines at 50 in Fig. 10, the tubing from which the flue is made may be circular in cross section and is flattened as shown at 51 into such form as may be desirable. It will be
65 preferable to expand the flattened tube

where it joins with the fire box 4'' at 52 to provide a tapered opening into the flue. A flattened tube of this type may be reversely bent upon itself at intervals with comparative ease to provide a tortuous pas-
70 sageway for the flue gases, and the rounded bends at 21'' are free from any obstructions which would hinder the passage of the gases therethrough. The adjacent walls of the reversely bent portions will be spaced from
75 each other to provide a fluid chamber as heretofore described in connection with Figs 1 to 5.

In the modification of my invention illustrated in Figs. 11 to 13 of the drawings I
80 have shown an upright boiler of the cylindrical type, preferably made of sheet metal, and comprising the side wall 54 having a top 55 welded or otherwise suitably secured thereon. Within the bottom of the outer
85 casing thus formed I provide a fire box 56 which may be made in the form of a dome shaped casting. This fire box is provided with an outlet 57 into a flue 58 which may be constructed in the manner hereinbefore
90 described with respect to the modification of my invention illustrated in Fig. 6, or in accordance with the modification illustrated in Fig. 8 of the drawings. In either case it will be observed that this flue will have the form of a flattened tube reversely bent upon
95 itself to provide a series of substantially parallel passages, the consecutive parallel portions of which are spaced from each other to provide an intervening fluid chamber. It will also be understood that the reverse bends in this passageway are curved throughout their length, as heretofore described, in order to obviate as much as possible any obstruction to the passage of flue
100 gases.

Suitable openings for cleaning the flue may be provided as indicated at 59, these openings being closed by suitable covers 60. The flue may be supported upon the fire box
110 56 by means of a plurality of stay rods 36'' secured intermediate the upper wall of the fire box 56 and the adjacent wall of the flue 58. Similar stay rods 37'' may be provided to support the flue with respect to the vertical wall 54 of the outer casing of the boiler.

In the modification of my invention illustrated in Figs. 14 and 15 of the drawings I
120 have shown a cylindrical boiler of the horizontal type having an outer wall 61, preferably made of sheet metal. A front wall 62 and a rear wall 63 are suitably secured to the cylindrical casing 61 by riveting or welding as may be desired, and the
125 outer casing thus formed is supported upon the base 64.

Mounted within the lower part of the outer casing is a fire box 65, preferably of cylindrical shape and supported in spaced rela-
130

tion to the outer casing by means of stay bolts 66. The rear wall 67 of the fire box may be secured in any suitable manner, as by riveting or welding, to the cylindrical casing forming the side walls of the fire box, and the front wall 68 may be similarly secured in place.

A suitable opening 69 is provided in the front wall 68 through which fuel may be placed in the fire box, this opening being closed by a door 70. A similar opening 71 may be provided for the removal of ash from the fire box, this opening being closed by a suitable door 72.

A flue 73, preferably made from a flattened tube as hereinbefore described, opens outwardly from the fire box as indicated at 74, and after being reversely bent upon itself to form a plurality of substantially parallel passages this flue passes outwardly through the outer casing as at 75. Each of the bends connecting the adjacent parallel passageways is in the form of a continuous curve, as heretofore described, and the upper bends in the flue may be provided with outlets 76 for flue gases. These outlets may open directly into the main flue outlet 75 through suitable pipes or passages 77, or they may open through pipes 78 to a pipe 79 opening into the main flue outlet 75 at 80.

A flue cleaning opening 81 located at the front of the boiler gives access to the flue outlet 75, and this opening may be closed by the suitable cover 82.

From the above detailed description of my invention, as embodied in the various modifications referred to, it will be apparent that I have devised a boiler that is of simple construction, efficient in use, and may be made at small cost as compared with boilers which have heretofore been used for similar purposes. It will also be apparent that I have devised a combustion chamber for such boilers that is simple to manufacture, and inexpensive as compared with constructions heretofore used. It will furthermore be apparent that I have devised a flue structure that is exceedingly simple to manufacture, inexpensive in comparison with similar structures heretofore known, and one that provides an extended heating surface and is at the same time free from obstruction to the passage of flue gases. It will also be clear that the construction of my improved flue is such that the current of flame and flue gases, when passing there-through, remains intact and undivided, thus functioning more efficiently in heating the fluid in contact therewith. It will be clear furthermore that, by my improvement, I provide a boiler in which the combustion chamber is entirely surrounded by the fluid to be heated, thus providing a maximum heating surface as compared with boilers heretofore used.

While I have described various modifications of my invention, it will be understood that these modifications merely illustrate desirable ways in which my invention may be put into practice, and other modifications may be resorted to without departing from the spirit of my invention as set out in the appended claims. I have shown the fuel door of the various modifications of my boiler construction located in the front wall. It will be understood, however, that this door may, if desired, be placed in the rear wall. I have also shown the flue outlet in the rear wall of various modifications, and in the upper wall of others. This outlet may be arranged adjacent the front of the boiler if desired, either in the upper wall or in the front wall.

Having thus described my invention, what I desire to secure by Letters Patent is:

1. In a boiler of the character described, an outer casing, a combustion chamber therein and spaced therefrom to provide a fluid chamber, said combustion chamber comprising a fire box and a flue leading therefrom, said flue comprising a flattened tube reversely bent upon itself to form a series of substantially parallel, curvilinearly connected passages spaced from each other to provide a fluid chamber between successive passages.

2. In a boiler of the character described, an outer casing, a fire box therein and spaced therefrom to provide a fluid chamber, a flue leading outwardly from the fire box through said fluid chamber, said flue comprising a flattened tube reversely bent upon itself to form a series of substantially parallel, curvilinearly connected passages spaced from each other.

3. In a boiler of the character described, a substantially cylindrical outer casing, a fire box therein and spaced from the walls thereof to provide a fluid chamber, a flue leading outwardly from the fire box through said fluid chamber to the exterior of the casing, said flue comprising a flattened tube reversely bent upon itself to form a series of substantially parallel, curvilinearly connected passages spaced from each other.

4. In a combustion chamber for a boiler of the character described, a fire box, a flue leading outwardly therefrom comprising a flattened tube reversely bent upon itself to form a series of substantially parallel passages spaced from each other to provide a fluid chamber between successive passages, the successive passages being connected to each other by a curved outer wall to permit flue gases to readily pass therethrough.

5. In a combustion chamber for a boiler of the character described, a fire box, a flue leading outwardly therefrom comprising a flattened tube reversely bent upon itself to form a series of substantially parallel and

