

Oct. 21, 1947.

F. LAMBACH

2,429,231

WARP GUIDES FOR ATTACHMENT TO A GUIDE BAR OF WARP KNITTING MACHINES

Filed Sept. 27, 1945

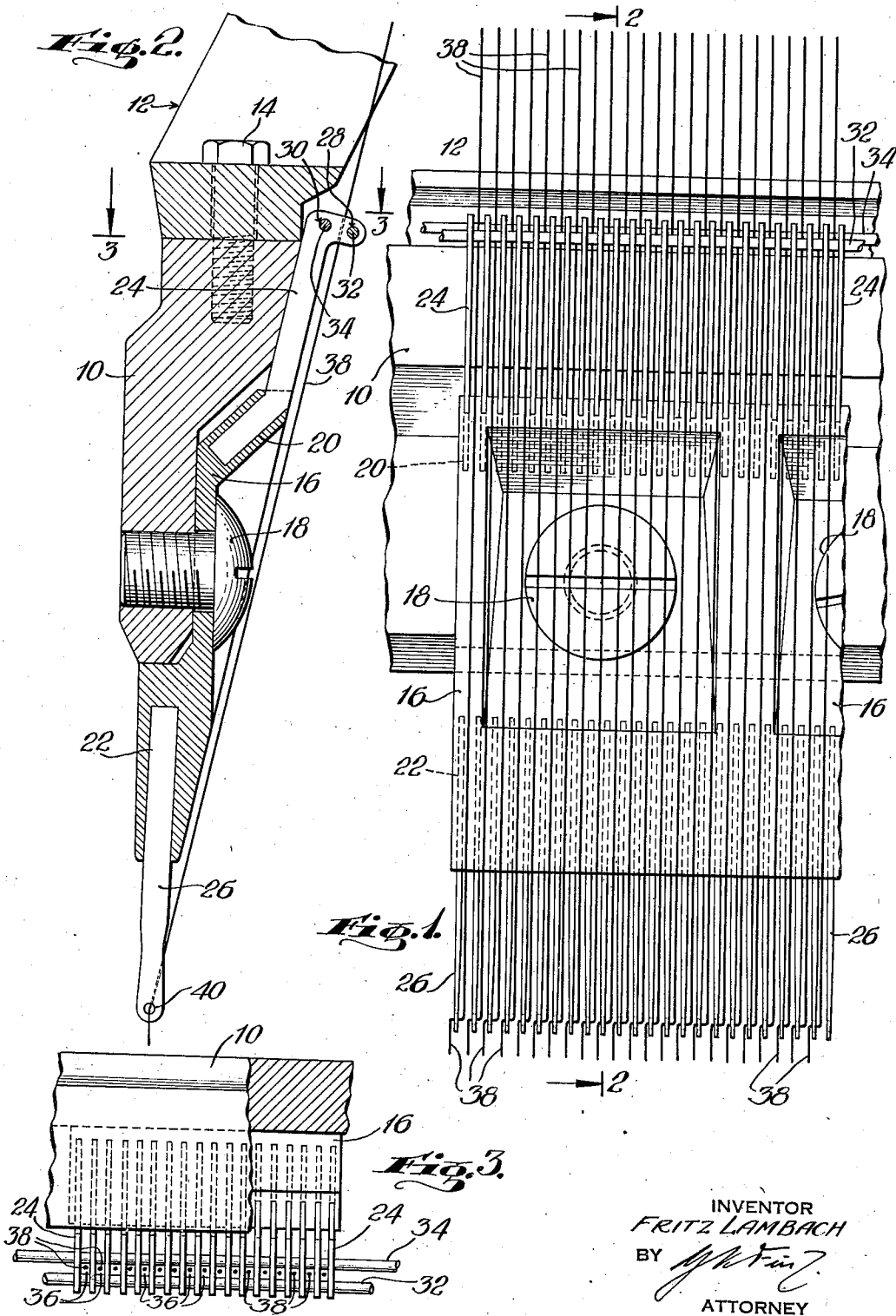

INVENTOR  
FRITZ LAMBACH  
BY *Fritz Lambach*  
ATTORNEY

# UNITED STATES PATENT OFFICE

2,429,231

## WARP GUIDE FOR ATTACHMENT TO GUIDE BARS OF WARP KNITTING MACHINES

Fritz Lambach, Tenafly, N. J.

Application September 27, 1945, Serial No. 618,873

5 Claims. (Cl. 66-86)

1

My invention relates to textile machines, and more particularly to warp guides for attachment to a guide bar of warp knitting machines.

An object of my invention is to provide warp guides with means reducing the friction between the warp yarn and the warp guide to a minimum.

Another object of my invention is to provide warp guides with guiding means at their warp yarn receiving end which eliminate bends in the warp yarns at said warp yarn receiving end.

A further object of my invention is to provide warp guides of a construction facilitating the threading of the warp yarns to a great extent.

With the above and other objects of the invention in view, the invention consists in the novel construction, arrangement and combination of various devices, elements and parts, as set forth in the claims hereof, certain of the same being described in the specification and being illustrated in the accompanying drawings forming part of this specification, wherein:

Fig. 1 is a fragmentary side elevational view of a set of warp guides mounted on a guide bar,

Fig. 2 is a sectional view taken on line 2-2 of Fig. 1, and

Fig. 3 is a sectional view taken on line 3-3 of Fig. 2, a portion of the guide bar being broken away.

10 indicates a guide bar attached to a guide bar holder 12 of a warp knitting machine by means of screws 14.

A series of blocks 16 is attached to the guide bar 10 by means of screws 18. The blocks 16 are arranged next to each other. Each block has a plurality of recesses 20 at its upper end and a plurality of recesses 22 at its lower end. An element 24 of sheet metal forming the warp yarn receiving end of the warp guide is inserted into each recess of said upper series of recesses 20. Likewise, an element 26 of sheet metal forming the warp yarn delivery end of the warp guide is inserted into each recess of the lower series of recesses 22. Of course, the elements 24 and 26 are secured to the block 16 in any suitable manner. As best shown in Fig. 1, each element 24 of the series of elements 24 is in line with an element 26 of the series of elements 26 so that a pair of elements 24 and 26 forms a warp guide. Although, thus, each warp guide consists of two connected separate elements 24 and 26, it is understood that each warp guide could be manufactured of a single integral element, if desired.

According to the invention, the warp yarn receiving end 24 of each warp guide is provided with two spaced apertures 28 and 30, and said ap-

2

ertures of the set of elements 24 are in register with each other, so as to form two rows of apertures. A wire or rod 32 is inserted into the row of apertures 28, and a wire or rod 34 is inserted into the row of apertures 30. Thus, the wires or rods 32 and 34 project laterally from the side of an element 24, which faces an adjacent element 24 of the set of elements, towards such an adjacent element. The wire or rod 32 is detachably inserted into the series of holes 28 for a purpose to be described hereinafter. The wire or rod 34 may also be detachably inserted into the series of holes 30; however, if desired, means may be provided for a rigid attachment of the rod or wire 34 to the elements 24. Said wires or rods 32 and 34 form guiding passages 36 between the elements 24 for the warp yarns 38.

Each of the elements 26 is provided with a hole 40 for engagement with a warp yarn 38 to be fed to the knitting implements of the warp knitting machine.

As will be readily understood from the illustration of Fig. 1, the arrangement of a guiding passage at the side of the warp yarn receiving end 24 of the warp guide 24, 26 eliminates any bend in the warp yarn 38 at said warp yarn receiving end. Furthermore, the detachable mounting of the guiding element or rod 32 facilitates the threading of the warp yarns. If the warp yarns are to be threaded, the rod or wire 32 is removed, so that the warp yarns may be easily placed into the spaces between the warp guides. Thereupon, the rod or wire 32 is again inserted into the row of apertures 28, whereby the guiding passages 36 for the warp yarns are formed by the two rods or wires 32 and 34. Of course, the warp yarns have to be threaded through the holes 40 at the warp yarn delivery end 26 of the warp guides.

According to the embodiment shown in the drawings, the guiding passage for the warp yarns at the side of the warp yarn receiving end 24 of the warp guides is formed by the two rods or wires 32 and 34. If desired, said guiding passages may also be formed in a different manner, for example by spaced guiding studs or the like mounted on the warp yarn receiving end 24 of the warp guides and projecting laterally therefrom.

I have described a preferred embodiment of my invention, but it is understood that numerous changes and omissions may be made without departing from the spirit and scope of the invention as set forth in the appended claims.

What I claim is:

1. In a set of warp guides for attachment to a guide bar of a warp knitting machine in combination: each warp guide of said set comprising a warp yarn receiving end having two spaced apertures, said spaced apertures of said warp guides being in register with each other so as to form two rows of apertures, a rod-like guiding element inserted into each of said two rows of apertures whereby said two rod-like guiding elements form guiding passages between the warp guides for the warp yarns, and each warp guide of said set comprising a warp yarn delivery end having a hole for engagement with a warp yarn to be fed to the knitting implements of the warp knitting machine.

2. In a set of warp guides as claimed in claim 1, at least one of said two rod-like guiding elements being detachably inserted into said row of apertures.

3. A warp guide for arrangement in a set of spaced warp guides attached to a guide bar of a warp knitting machine, comprising: a warp yarn receiving end, spaced guiding elements mounted on said warp yarn receiving end at a side of the latter facing an adjacent warp guide in the set of warp guides, said spaced guiding elements projecting laterally from said side of the warp yarn receiving end towards the adjacent warp guide and being arranged for forming a guiding passage for a warp yarn at said side of the warp guide, and a warp yarn delivery end having a hole for engagement with said warp yarn to be fed to the knitting implements of the warp knitting machine.

4. A warp guide for arrangement in a set of spaced warp guides attached to a guide bar of a warp knitting machine, comprising: a warp yarn receiving end having spaced apertures, said apertures passing from a side of the warp yarn receiving end facing an adjacent warp yarn receiving end in the set of warp guides through the body

of the warp yarn receiving end to the opposite side of the warp yarn receiving end, said apertures being capable of receiving guiding elements projecting laterally from such a side of the warp yarn receiving end towards the adjacent warp guide, and a warp yarn delivery end having a hole for engagement with said warp yarn to be fed to the knitting implements of the warp knitting machine.

5. A warp guide for arrangement in a set of spaced warp guides attached to a guide bar of a warp knitting machine, comprising: a warp yarn receiving end, spaced guiding elements mounted on said warp yarn receiving end at a side of the latter facing an adjacent warp guide in the set of warp guides, said spaced guiding elements projecting laterally from said side of the warp yarn receiving end towards the adjacent warp guide and being arranged for forming a guiding passage for a warp yarn at said side of the warp guide, at least one of said guiding elements being detachably mounted on said warp yarn receiving end, and a warp yarn delivery end having a hole for engagement with said warp yarn to be fed to the knitting implements of the warp knitting machine.

FRITZ LAMBACH.

REFERENCES CITED

The following references are of record in the file of this patent:

UNITED STATES PATENTS

Number	Name	Date
464,995	Roberts	Dec. 15, 1891
2,022,448	Wirth	Nov. 26, 1935

FOREIGN PATENTS

Number	Country	Date
65,536	Germany	Nov. 22, 1892
130,564	Germany	May 15, 1902