



INTERNATIONAL APPLICATION PUBLISHED UNDER THE PATENT COOPERATION TREATY (PCT)

(51) International Patent Classification ⁵ :
D06B 23/18

A1

(11) International Publication Number: WO 94/10367

(43) International Publication Date: 11 May 1994 (11.05.94)

(21) International Application Number: PCT/IT92/00114

(22) International Filing Date: 2 November 1992 (02.11.92)

(71)(72) Applicant and Inventor: ALBERTO, Pietro [IT/IT];
Strada Masserano Calaria, 70, I-13051 Biella (IT).(74) Agents: ADORNO, Silvano; Società Italiana Brevetti, Via
Carducci 8, I-20123 Milano (IT) et al.(81) Designated States: JP, US, European patent (AT, BE, CH,
DE, DK, ES, FR, GB, GR, IE, IT, LU, MC, NL, SE).

Published

With international search report.

(54) Title: AN IMPROVED DEVICE FOR FEEDING INTO AND WITHDRAWING FABRICS FROM AN AUTOCLAVE FOR CONTINUOUS DECATIZING

(57) Abstract

A device for feeding into and respectively withdrawing from an autoclave (1), of fabric (11) to be continuously decatized under pressure, together with a felt back cloth (3), includes in addition to the already known lead-in center cylinder (5) between the two runs of fabric going in and coming out (3, 11; 3', 11'), a pair of side cylinders (4, 6) cooperating with the above (5) and replacing the already known inflatable gaskets. It is the fabric-felt assembly (3, 11) itself that, by being compressed between the two pairs of cylinders (4, 5; 5, 6) builds a barrier against steam leakages. The center cylinder (5) and/or the two side cylinders (4, 6) may be recessed in order to define, in the nip area, a recess shallower than the thickness of the paired materials. In case all three cylinders (4, 5, 6) are smooth, the distance thereof will be suitably controlled for said purpose, and in both nip areas antifriction material pads (13, 13'), such as Teflon™, are preferably provided, in order to seal, at both ends of the cylinders, the gaps existing between the end of the felt and the side support members (15) of said cylinders.

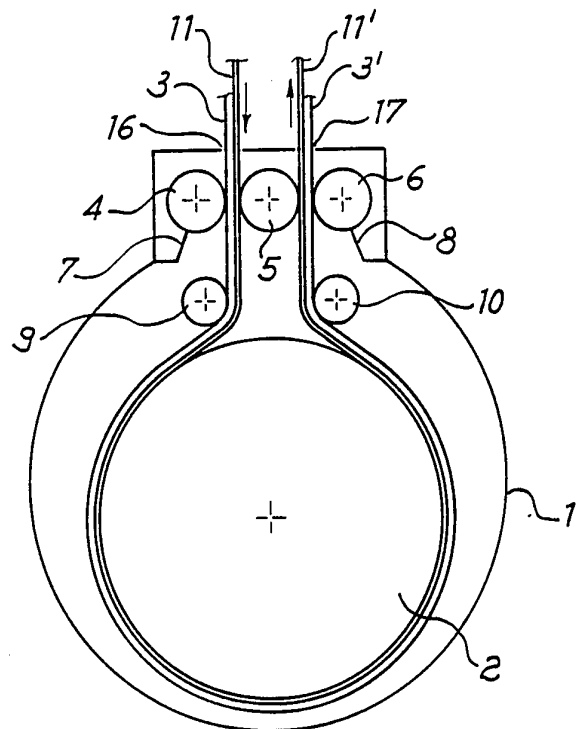

FOR THE PURPOSES OF INFORMATION ONLY

Codes used to identify States party to the PCT on the front pages of pamphlets publishing international applications under the PCT.

AT	Austria	GB	United Kingdom	MR	Mauritania
AU	Australia	GE	Georgia	MW	Malawi
BB	Barbados	GN	Guinea	NE	Niger
BE	Belgium	GR	Greece	NL	Netherlands
BF	Burkina Faso	HU	Hungary	NO	Norway
BG	Bulgaria	IE	Ireland	NZ	New Zealand
BJ	Benin	IT	Italy	PL	Poland
BR	Brazil	JP	Japan	PT	Portugal
BY	Belarus	KE	Kenya	RO	Romania
CA	Canada	KG	Kyrgystan	RU	Russian Federation
CF	Central African Republic	KP	Democratic People's Republic of Korea	SD	Sudan
CG	Congo	KR	Republic of Korea	SE	Sweden
CH	Switzerland	KZ	Kazakhstan	SI	Slovenia
CI	Côte d'Ivoire	LI	Liechtenstein	SK	Slovakia
CM	Cameroon	LK	Sri Lanka	SN	Senegal
CN	China	LU	Luxembourg	TD	Chad
CS	Czechoslovakia	LV	Latvia	TG	Togo
CZ	Czech Republic	MC	Monaco	TJ	Tajikistan
DE	Germany	MD	Republic of Moldova	TT	Trinidad and Tobago
DK	Denmark	MG	Madagascar	UA	Ukraine
ES	Spain	ML	Mali	US	United States of America
FI	Finland	MN	Mongolia	UZ	Uzbekistan
FR	France			VN	Vict Nam
GA	Gabon				

" AN IMPROVED DEVICE FOR FEEDING INTO AND WITHDRAWING
FABRICS FROM AN AUTOCLAVE FOR CONTINUOUS DECATIZING"

This invention concerns an improved device for feeding
into and withdrawing a fabric from a pressurized autoclave
5 for continuous decatizing, wherein friction is reduced
to a minimum and simultaneously an optimum sealing
against steam leakages is provided.

A device is already known for a leakproof introduct-
ion of a fabric into an autoclave for continuous
10 decatizing, as described and claimed in Patent Applicat-
ion MI91001119 filed on April 23, 1991 by the present
Applicant and Inventor, which device substantially
includes a rotating cylinder adapted to seal the slit
provided for the fabric and the related back cloth to
15 enter the autoclave or exit therefrom, as well as two
juxtaposed resilient members acting as seal-
ing gaskets. However, it is apparent that friction
developing between the rotating center member and the
pair of stationary side gaskets, preferably comprising
20 inflatable air bags, may be too high because of the wear
it may cause. To waive this problem, sheets of anti-
friction material are inserted between the cylinder and
the side gaskets, possibly wrapped around special
rollers in order to be able to move forward, continuous-
25 ly or intermittently, for the purpose of changing the

SUBSTITUTE SHEET

contact area with said gaskets.

However said approach might not be considered completely satisfactory mainly when particularly abrasive felts are used as back cloths, while it is apparent that there is
5 no way to reduce below a certain threshold the friction which develops between a rotating and a stationary surface.

Therefore, it is an object of this invention to reduce said friction as much as possible by replacing the
10 stationary gaskets with rotating side cylinders, whereby only revolving friction develops which is certainly lower than the sliding friction likely to arise at the stationary surface of the rubber gaskets. In any case, sealing is provided by said felt associated with the
15 fabric, whose large thickness allows it to be compressed in the nip between the cylinders, whereby it actually operators as a real gasket.

According to a preferred embodiment, the engagement area between center cylinder and the pair of side cylinders
20 defines a nip which is not so deep as the thickness of the two associated materials (the felt and the fabric) in that the side surface of the center cylinder and/or of the pair of side cylinders is recessed for a width not narrower than the felt width.

25 In a further embodiment, the three cylinders have smooth

SUBSTITUTE SHEET

surfaces whose mutual distances are smaller than the thickness of the two associated materials, antifriction material pads being provided in this case at the two nips, on either side of the cylinders, in order to assure side sealing against steam leakages.

The above and other objects, advantages and features of this invention will become more apparent from the following detailed description of some embodiments described herein for exemplary and non limiting purposes, reference being made to the attached drawings, wherein:

Figure 1 is a cross-sectional schematic of a continuous decatizing autoclave provided with the device according to this invention; and

Figures 2, 3 and 4 are schematic and partial top plan views of Figure 1, showing the fabric introduction and withdrawing area, for three different embodiments of the introducing and withdrawing cylinders.

Referring now to the drawing, as in the above mentioned previous patent application, a continuous decatizing autoclave 1 includes a rotating foraminous cylinder 2, preferably lined with a felt (not shown in the drawing), bearing fabric 11 wrapped therearound together with a back cloth 3 which is preferably a substantially thick felt. Fabric 11 is thus subjected to the action of steam

SUBSTITUTE SHEET

under pressure produced inside the autoclave and to a squeezing condition caused by being sandwiched between the back cloths, and in such a way a particular finish is obtained which is typical of this decatizing process.

5 According to this invention, felt 3 and fabric 11 are brought into the autoclave by going through the nip between a pair of rotating cylinders 4 and 5, and they come out from the autoclave with respective reference numbers 3', 11' by going through the nip between

10 cylinders 5 and 6. The route around foraminous cylinder 2 begins and ends substantially at the pair of guide rollers 9 and 10 respectively.

In order to avoid heavy steam leakages to the environment and the related pressure drops within the autoclave, it is necessary to provide the best sealing at

15 the nips between the cylinders where the associated materials are fed into and withdrawn from the machine. For this purpose, in order to prevent peripheral steam leakages around side cylinders 4 and 6,

20 resilient sheet gaskets 7 and 8 are provided, having their free end resting on the surface of cylinders 4 and 6 respectively in order to avoid that above cylinders 4, 5 and 6 there is a steam pressure comparable to the one established within the autoclave, so that it is not

25 necessary to provide gaskets having a high sealing

SUBSTITUTE SHEET

effect at regions 16, 17 where the materials are brought in or pulled out from the apparatus.

In this way, the sealing action is focused at the nip areas between cylinder 5 and the pair of side cylinders 4 and 6. For that purpose, the three cylinders may have different shapes, while being all adapted to keep both felt 3 and fabric 11 in a compressed condition whereby the two materials, so compressed, build a sealing and a barrier against steam leakage outflows. In any case, the distance between the cylinders, and more particularly between the cylinder surfaces traversed by the felt and the fabric, is shorter than the total thickness of the two materials, whereby the latter must get compressed.

Figure 2 shows the preferred embodiment wherein the pair of outer cylinders 4 and 6 have a smooth outer surface, with a uniform cross section, while center cylinder 5 is preferably recessed for a depth and length suitable to receive felt 3 and fabric 11 therein, while retaining two portions 12 of larger cross section at both ends. As an example, assuming that the felt is 180 cm wide and 5 mm thick, the recessed area will be wider than 180 cm, and shallower than 5 mm, whereby said felt may lie down perfectly breadthwise, while remaining slightly compressed in the thickness direction, for sealing purposes. It should be noted that the felt is itself

SUBSTITUTE SHEET

compressible.

End regions 12 of cylinder 5 may be preferably lined with a rubber-like or resinous material, in order to improve sealing and to avoid steam leakages from the ends, where the "gasket" provided by the paired compressed materials is missing. It should be noted that this resilient lining may be advantageously applied to all the cylinders, including the side ones 4 and 6, in order to improve the sealing and increase felt compression.

Referring now to Figure 3, there is shown therein a further embodiment of the introduction and withdrawing cylinders wherein the peripheral recess is provided on both outer cylinders 4 and 6, while inner cylinder 5 is smooth. Of course, the same remarks made previously referring to Figure 2, concerning width and depth of the recess still hold in this case. An embodiment might also be provided wherein all the three cylinders are recessed, but in this case it should be borne in mind that the sum of the depths of the pair of matching recessed areas should be appropriate to retain the felt and the fabric under a pre-compressed condition, in that it is slightly less than the thickness of the cloths.

On the other hand, sometimes the felt, being subjected to the steam pressure and the mechanical strain imposed

SUBSTITUTE SHEET

thereupon, has a tendency to shrink heightwise with time. When using recessed cylinders, in order to avoid that the play between the edge of the felt that has shrunk so far and the ends of the recessed area may become exaggerated whereby the sealing may be jeopardized, it will be preferable to use the approach shown in Figure 4, with the three cylinders completely smooth, free of any recess. Felt 3 and fabric 11 are compressed against each other in that the mutual distance between cylinders will be adjusted to remain shorter than the thickness of the associated materials. In order to close the slit left between the felt edge and the side members supporting the cylinders, where a steam leakage might take place, antifriction material pads 13, 13' are provided, typically made of teflon or the like. Therefore these pads, a total of four, provide sealing gaskets replacing the non-recess ends 12 of the cylinders, according to previous Figures 2 and 3, with the least possible friction. While felt 3 progressively shrinks in height, as mentioned above, said pads may be made to move forwards and inwards relative to the cylinders, by means of any known mechanism, inside or outside the autoclave. Threaded devices 14, 14' are shown in Figure 4. In such a way, the slit left between the outer edges of back cloth 3 and side members 15

SUBSTITUTE SHEET

CLAIMS

1. A device for feeding into and withdrawing fabrics from
an autoclave (1) for continuous decatizing, around a
foraminous rotating cylinder (2), with guide rollers (9,
5 10) at the beginning and at the end of the route around
said cylinder (2), with fabric (11) being associated
with a back cloth comprised of a felt (3), characterized
in that it comprises, in combination with a rotating
center cylinder (5), a pair of side cylinders, respectively
10 One (4) for bringing in paired materials (3, 11) and another (6) on the
opposite side for pulling out paired materials (3', 11')
from the autoclave, the distance between
the surfaces of said cylinders (4, 5, 6) in the nip areas
with said materials (3, 11; 3', 11') being
15 shorter than the total thickness of the paired materials.

2. The device of claim 1, characterized in that it in-
cludes peripheral sealing gaskets (7, 8) on outer
cylinders (4, 6) comprising resilient sheets whose free
end is adapted to slide in contact with the side surface
20 of said cylinders, for the whole length thereof.

3. The device of claim 1 or 2, characterized in that
only the center rotating cylinder (5) is peripherally recessed
for a length at least equal to the width of paired
materials (3, 11; 3', 11'), the unrecessed end areas of
25 cylinder (5) being lined with a resilient material.

SUBSTITUTE SHEET

4. The device of claim 1 or 2, characterized in that the pair of outer cylinders (4, 6) are recessed on the side surface thereof for a length equal at least to the maximum width of the paired materials (3, 11: 3', 11'),
5 unrecessed end areas (12) of said cylinders (4, 6) being lined with a resilient material.

5. The device of claim 4, characterized in that also center cylinder (5) is recessed, the depth of the recessed areas of each cylinder being such that, by
10 matching together in the engagement area, it is less than the total thickness of the paired materials (3, 11; 3', 11').

6. The device of claim 1 or 2, characterized in that the three cylinders (4, 5, 6) are all substantially
15 smooth and they have a constant cross section, and their center distances are such as to leave a nip, between the side surface of center cylinder (5) and the pair of side ones (4, 6), which is slightly thinner than the total thickness of the paired materials (3, 11; 3', 11').

20 7. The device of claim 6, characterized in that it is provided with two pairs of antifriction material pads (13, 13'), for instance teflon, inserted within said two interspaces and on either side thereof, for laterally sealing said interspaces.

25 8. The device of claim 7, characterized in that it

includes forward moving means (14, 14') for said pads (13, 13') within said interspaces, adapted to adjust, by being controlled from outside, the depth of penetration of said pads according to said variable width of the
5 paired materials, particularly of felt (3, 3').

9. A device according to any one of the above claims, wherein all the cylinders (4, 5, 6) are completely lined with a resilient material, for instance rubber or the like.

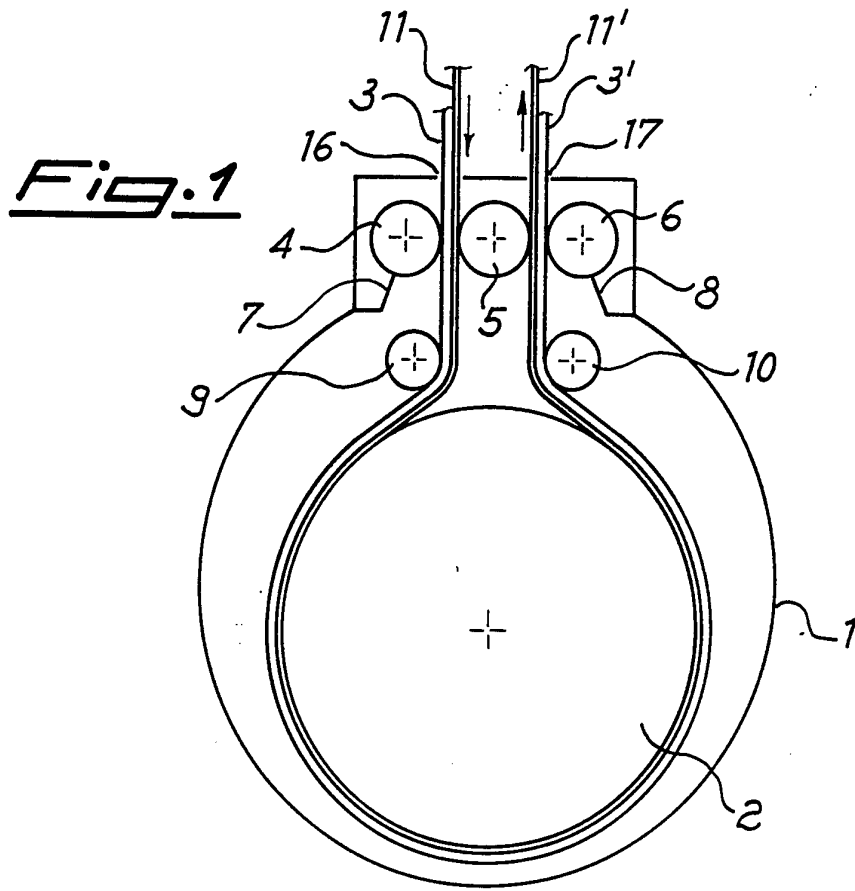

Fig. 3

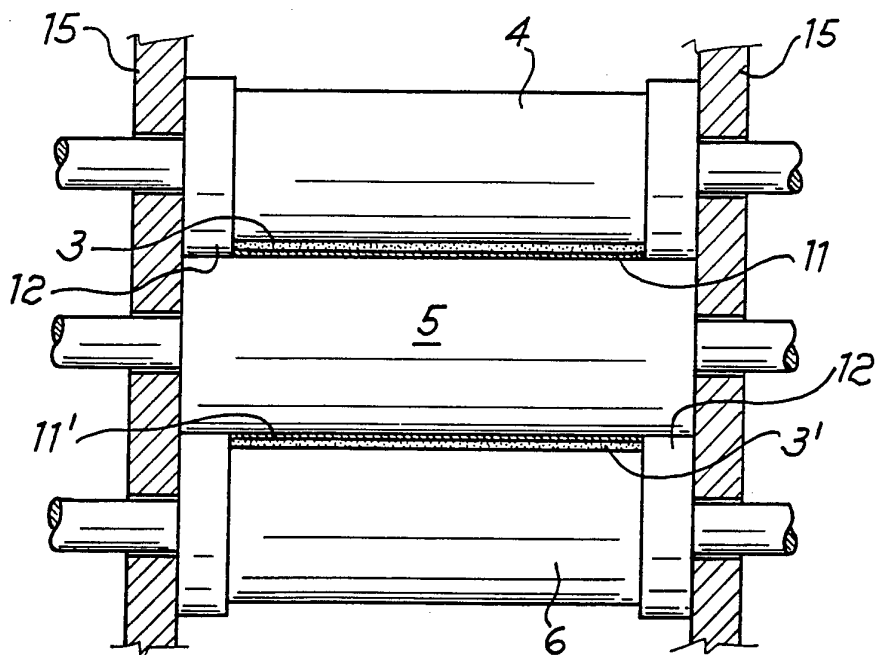

Fig. 2

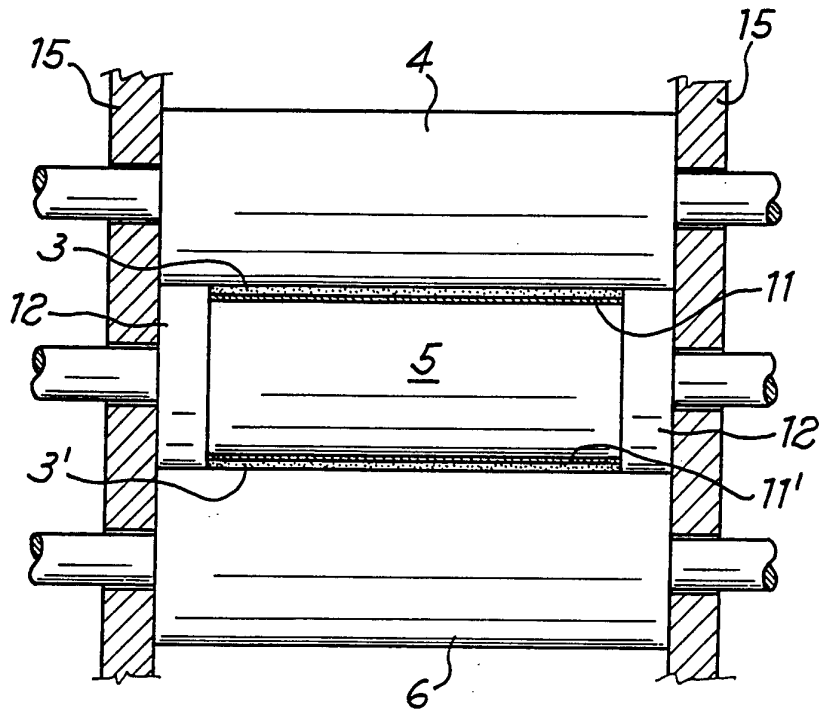
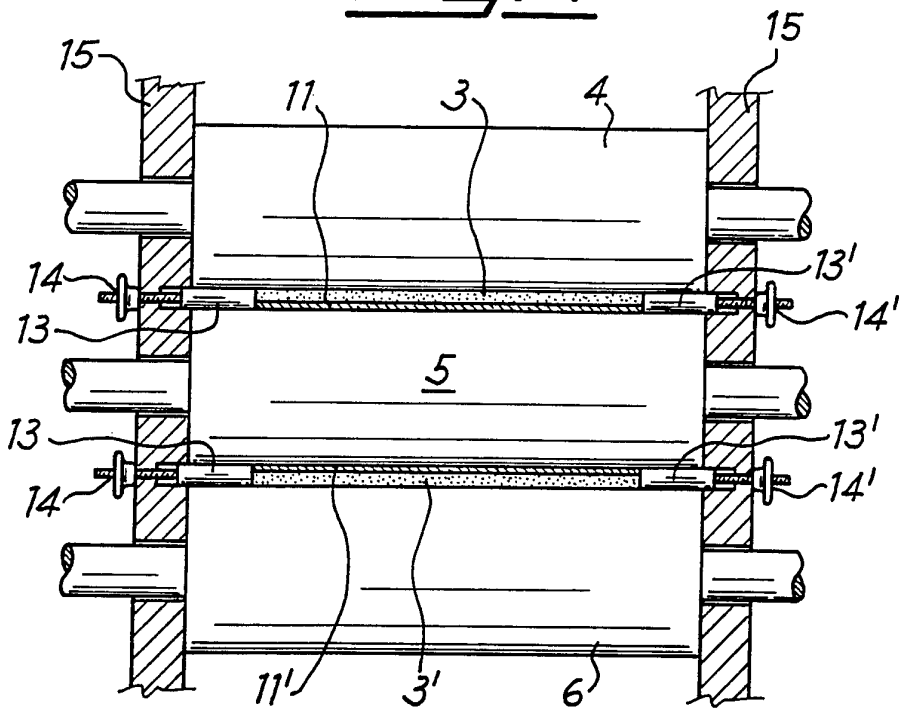

Fig. 4



INTERNATIONAL SEARCH REPORT

International Application No

PCT/IT 92/00114

I. CLASSIFICATION OF SUBJECT MATTER (if several classification symbols apply, indicate all) ⁶		
According to International Patent Classification (IPC) or to both National Classification and IPC Int.Cl. 5 D06B23/18		
II. FIELDS SEARCHED		
Minimum Documentation Searched ⁷		
Classification System	Classification Symbols	
Int.Cl. 5	D06B ; D06C	
Documentation Searched other than Minimum Documentation to the Extent that such Documents are Included in the Fields Searched ⁸		
III. DOCUMENTS CONSIDERED TO BE RELEVANT ⁹		
Category ¹⁰	Citation of Document, ¹¹ with indication, where appropriate, of the relevant passages ¹²	Relevant to Claim No. ¹³
X	DE,B,1 206 866 (ARTOS) 23 June 1966 see figure 8	1,2,6-8
A	FR,A,2 314 125 (SANDO IRON WORKS) 7 January 1977	
A	US,A,4 002 346 (KLEINWEFERS) 11 January 1977	
A	DE,A,2 810 660 (KLEINWEFERS) 13 September 1979	
<p>¹⁰ Special categories of cited documents:</p> <p>"A" document defining the general state of the art which is not considered to be of particular relevance</p> <p>"E" earlier document but published on or after the international filing date</p> <p>"L" document which may throw doubts on priority claim(s) or which is cited to establish the publication date of another citation or other special reason (as specified)</p> <p>"O" document referring to an oral disclosure, use, exhibition or other means</p> <p>"P" document published prior to the international filing date but later than the priority date claimed</p> <p>"T" later document published after the international filing date or priority date and not in conflict with the application but cited to understand the principle or theory underlying the invention</p> <p>"X" document of particular relevance; the claimed invention cannot be considered novel or cannot be considered to involve an inventive step</p> <p>"Y" document of particular relevance; the claimed invention cannot be considered to involve an inventive step when the document is combined with one or more other such documents, such combination being obvious to a person skilled in the art.</p> <p>"&" document member of the same patent family</p>		
IV. CERTIFICATION		
Date of the Actual Completion of the International Search	Date of Mailing of this International Search Report	
14 MAY 1993	08.06.93	
International Searching Authority	Signature of Authorized Officer	
EUROPEAN PATENT OFFICE	PETIT J-P	

**ANNEX TO THE INTERNATIONAL SEARCH REPORT
ON INTERNATIONAL PATENT APPLICATION NO.**

IT 9200114
SA 65167

This annex lists the patent family members relating to the patent documents cited in the above-mentioned international search report. The members are as contained in the European Patent Office EDP file on
The European Patent Office is in no way liable for these particulars which are merely given for the purpose of information. 14/05/93

Patent document cited in search report	Publication date	Patent family member(s)	Publication date
DE-B-1206866		None	
FR-A-2314125	07-01-77	JP-A- 51149977 BE-A- 842776 DE-A- 2625871 GB-A- 1516436	23-12-76 01-10-76 23-12-76 05-07-78
US-A-4002346	11-01-77	DE-A- 2431900 CH-A- 600024 FR-A- 2277175 GB-A- 1454477 JP-C- 888537 JP-A- 51032879 JP-B- 52017144 NL-A- 7507897	29-01-76 15-06-78 30-01-76 03-11-76 10-11-77 19-03-76 13-05-77 06-01-76
DE-A-2810660	13-09-79	GB-A, B 2019911 JP-A- 54125794 NL-A- 7901812 US-A- 4301665	07-11-79 29-09-79 13-09-79 24-11-81