

(12) STANDARD PATENT
(19) AUSTRALIAN PATENT OFFICE

(11) Application No. **AU 2003229660 C1**

(54) Title
Electronic display and control device for a measuring device

(51) International Patent Classification(s)
G01C 1/04 (2006.01) **G01S 7/481** (2006.01)
G01C 15/00 (2006.01) **G01S 7/497** (2006.01)
G01S 7/00 (2006.01) **G01S 7/51** (2006.01)

(21) Application No: **2003229660** (22) Date of Filing: **2003.04.14**

(87) WIPO No: **WO04/036145**

(30) Priority Data

(31) Number	(32) Date	(33) Country
02022820.1	2002.10.12	EP

(43) Publication Date: **2004.05.04**

(43) Publication Journal Date: **2004.06.10**

(44) Accepted Journal Date: **2008.09.18**

(44) Amended Journal Date: **2009.02.19**

(71) Applicant(s)
Leica Geosystems AG

(72) Inventor(s)
Vorburger, Pius;Kern, Gerhard;Hinderling, Jurg;Schneider, Klaus

(74) Agent / Attorney
Spruson & Ferguson, Level 35 St Martins Tower 31 Market Street, Sydney, NSW, 2000

(56) Related Art
WO 1999/060335
US 5219226

(12) NACH DEM VERTRAG ÜBER DIE INTERNATIONALE ZUSAMMENARBEIT AUF DEM GEBIET DES
PATENTWESENS (PCT) VERÖFFENTLICHTE INTERNATIONALE ANMELDUNG

(19) Weltorganisation für geistiges Eigentum
Internationales Büro



(43) Internationales Veröffentlichungsdatum
29. April 2004 (29.04.2004)

PCT

(10) Internationale Veröffentlichungsnummer
WO 2004/036145 A1

(51) Internationale Patentklassifikation⁷: G01C 1/04

(21) Internationales Aktenzeichen: PCT/EP2003/003851

(22) Internationales Anmeldedatum:
14. April 2003 (14.04.2003)

(25) Einreichungssprache: Deutsch

(26) Veröffentlichungssprache: Deutsch

(30) Angaben zur Priorität:
02022820.1 12. Oktober 2002 (12.10.2002) EP

(71) Anmelder (für alle Bestimmungsstaaten mit Ausnahme von
US): LEICA GEOSYSTEMS AG [CH/CH]; Heinrich-
Wild-Strasse, CH-9435 Heerbrugg (CH).

(72) Erfinder; und

(75) Erfinder/Anmelder (nur für US): KERN, Gerhard
[AT/AT]; Bleiche 28, A-6840 Götzis (AT). SCHNEIDER,

Klaus [AT/AT]; Bahngasse 15b, A-6850 Dornbirn (AT).
VORBURGER, Pius [CH/CH]; Schnabelweg 2, CH-9442
Berneck (CH). HINDERLING, Jürg [CH/CH]; Gehren-
strasse 11, CH-9437 Marbach (CH).

(74) Anwalt: KAMINSKI, Susanne; Büchel, Kaminski &
Partner, Austrasse 79, FL-9490 Vaduz (LI).

(81) Bestimmungsstaaten (national): AE, AG, AL, AM, AT,
AU, AZ, BA, BB, BG, BR, BY, BZ, CA, CH, CN, CO, CR,
CU, CZ, DE, DK, DM, DZ, EC, EE, ES, FI, GB, GD, GF,
GH, GM, HR, HU, ID, IL, IN, IS, JP, KE, KG, KP, KR,
KZ, LC, LK, LR, LS, LT, LU, LV, MA, MD, MG, MK,
MN, MW, MX, MZ, NO, NZ, OM, PH, PL, PT, RO, RU,
SC, SD, SE, SG, SK, SL, TJ, TM, TN, TR, TT, TZ, UA,
UG, US, UZ, VC, VN, YU, ZA, ZM, ZW.

(84) Bestimmungsstaaten (regional): ARIPO-Patent (GH,
GM, KE, LS, MW, MZ, SD, SI, SZ, TZ, UG, ZM, ZW),
eurasisches Patent (AM, AZ, BY, KG, KZ, MD, RU, TJ,

[Fortsetzung auf der nächsten Seite]

(54) Title: ELECTRONIC DISPLAY AND CONTROL DEVICE FOR A MEASURING DEVICE

(54) Bezeichnung: ELEKTRONISCHE ANZEIGE- UND STEUERVORRICHTUNG FÜR EIN MESSGERÄT

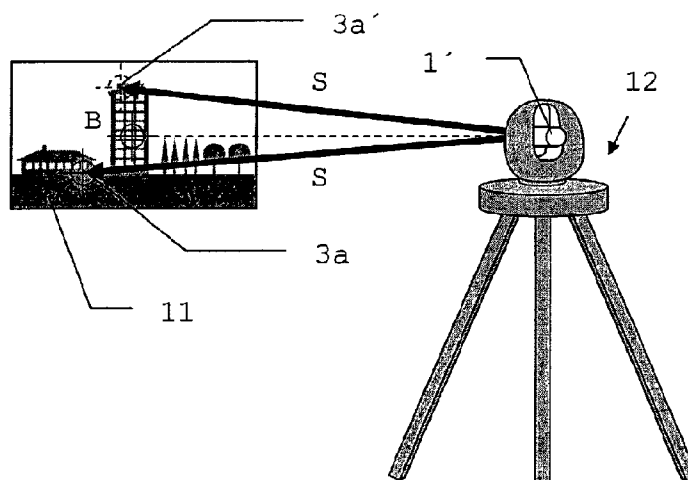

(57) Abstract: The invention relates to an electronic display and control device for a geodesic measuring device (12) containing capturing means (1') and representation means for detecting and reproducing a measuring range (11) together with input means for controlling the measuring processes. The radiation beam (S) necessary for said measuring processes is emitted by a radiation source and is influenced in the direction of emission thereof by orientating means such that it can be orientated onto a selected target within the measuring range (11) without the capturing means being displaced. Determining the target and initiating the measuring process occurs by displacing a position mark (3a) on a screen. A suitable operating module can be produced by suitably combining the representation means with means for inputting data. Said module can also be used independently from and separately from a measuring device (12,12') which is connected thereto by communication means. The use of said module together with a plurality of measuring devices as sensor components, enables the formation of remote-controlled geodesic measuring systems.

[Fortsetzung auf der nächsten Seite]

WO 2004/036145 A1



TM), europäisches Patent (AT, BE, BG, CH, CY, CZ, DE, DK, EE, ES, FI, FR, GB, GR, HU, IE, IT, LU, MC, NL, PT, RO, SE, SI, SK, TR), OAPI-Patent (BF, BJ, CF, CG, CI, CM, GA, GN, GQ, GW, ML, MR, NE, SN, TD, TG).

Zur Erklärung der Zweibuchstaben-Codes und der anderen Abkürzungen wird auf die Erklärungen ("Guidance Notes on Codes and Abbreviations") am Anfang jeder regulären Ausgabe der PCT-Gazette verwiesen.

Veröffentlicht:

— mit internationalem Recherchenbericht

(57) Zusammenfassung: Eine elektronische Anzeige- und Steuervorrichtung für ein geodätisches Messgerät (12) beinhaltet Aufnahmemittel (1') und Darstellungsmittel zur Erfassung und Wiedergabe eines Messbereichs (11) zusammen mit Eingabemitteln zur Steuerung von Messvorgängen. Das für diese Messvorgänge benötigte Strahlungsband (S) wird von einer Strahlungsquelle emittiert und über Ausrichtmittel in seiner Emissionsrichtung so beeinflusst, dass es innerhalb des Messbereichs (11) auf ausgewählte Zielpunkte ausgerichtet werden kann ohne dass eine Bewegung der Aufnahmemittel erfolgen muss. Dabei erfolgt die Festlegung der Zielpunkt und die Auslösung des Messvorgangs durch die Bewegung einer Positionsmarke (3a) auf einem Bildschirm. Durch eine geeignete Zusammenfassung der Darstellungsmittel mit den Mitteln zur Eingabe von Daten kann ein eigenes Handhabungsmodul geschaffen werden, das auch unabhängig und abgesetzt von einem Messgerät (12, 12') verwendet werden kann und mit diesem über Kommunikationsmittel in Verbindung steht. Die Verwendung eines solchen Moduls zusammen mit mehreren Messgeräten als Sensorkomponenten erlaubt die Gestaltung fernbedienbarer geodätischer Vermessungssysteme.

Electronic display and control device for a measuring device

5 The invention relates to an electronic display and control device according to the precharacterizing clause of Claim 1 and a geodetic measuring device according to Claim 15, a module component according to Claim 23 and a geodetic surveying system according to Claim 24.

10

A large number of measuring devices has been known since antiquity for the recording of properties of defined points in a measuring environment, in particular of data having a three-dimensional reference. The location of a measuring device in addition to any existing reference points, and direction, distance and angle relative to measuring points, are recorded as three-dimensional standard data. Improvements to date generally related to the use of new technical methods having higher accuracy and speed.

20

A generally known example of such measuring devices is the theodolite. An overview of geodetic measuring devices of the prior art is given in "Elektronische Entfernungs- und Richtungsmessung" [Electronic distance and direction measurement] by R. Joeckel and M. Stober, 4th Edition, Verlag Konrad Wittwer, Stuttgart 1999, and "Electronic Distance Measurement" by J.M. Rüeger, 4th Edition, Springer-Verlag, Berlin, Heidelberg, 1996. However, such devices always require a user who works directly at the device and sets up the measuring device, generally with the aid of special aligning

30

means, such as, for example, optical telescopes, for the points to be measured.

Because the beam path is generally to be utilized for the human eye and the measuring process together, such devices have to be technically designed in the manner of a telescope, resulting in limitations of the embodiment.

10 By combining a geodetic device with a screen which can be moved relative to this device or can be mounted independently, advantages can be achieved from the ergonomic and safety points of view. The conventional eyepiece of the telescope is replaced by electronic recording means, so that the operator no longer need be tied to the device as in the past and furthermore, the requirements or limitations resulting from the use of the human eye can be eliminated. The device and the measurements to be carried out therewith are controlled electronically via the display of the screen and a suitable input device for data and control commands. The measurements can then be carried out after alignment by various methods, such as, for example, by measurement of the bearing with supplementary distance measurement by triangulation or by means of a laser.

The patents JP 02130409 A and JP 03167412 A disclose a combination of a theodolite with a video camera, by means of which rapid and exact three-dimensional measurements are to be permitted. Here, by means of two theodolite/video camera combinations, recordings of images by the respective camera and angle measurements by means of theodolites are made simultaneously. In

each case, the axes of video camera and theodolite are parallel so that the angle measurement of a theodolite is linked to the images recorded by the camera of this combination. The three-dimensional positions of the
5 imaged objects can be derived from at least two images recorded at different angles.

European Patent Application EP 0 481 278 and the associated German Utility Model DE 90 07 731 U disclose
10 a measuring device for position determination of points in space which can be optoelectronically displayed. The measuring device has a movable measuring head with a camera as a target acquisition device and a distance measuring device whose sighting axes are precisely
15 aligned with one another. A target point is surveyed by acquiring it with the camera, and the camera axis is then aligned with the target point. Precise alignment of the distance measuring device is also associated therewith, so that its axis likewise points to the
20 point to be surveyed.

The European Patent Application having the Application No. 01127378 of the same Applicant describes a measuring device in which operation is effected in an
25 ergonomically advantageous manner by a separation of recording means and display means. By a suitable combination of the display means with the means for inputting data, it is possible to create a separate handling module which can also be used independently of
30 and remote from the measuring device and is connected to the latter via communication means. The use of such a module together with a plurality of measuring devices as sensor components permits the design of remote

controllable geodetic surveying systems. Within a displayed measuring range, it is possible to move a position mark, by means of which parameters of a measuring process can be established and the measuring process initiated. The following measuring process aligns the components of the measuring device which are required for the measurement with the position determined by the position mark, and the measurement is carried out.

10

International PCT Application WO 99/60335 discloses a geodetic device which acquires a target range by means of a camera and displays it on a screen. Within this range, targets can be selected and their distance can be measured by a distance measuring means by aligning the axis of the distance measuring means as a complete device with the selected target. Camera and distance measuring means are moved either together or independently of one another by means of motors.

20

All devices of the prior art which have been described require the movement of the entire device or of a measuring head which comprises both recording and measuring means or at least complete measuring devices for each measurement to a point. For each measuring process, it is therefore necessary to move components of the measuring device which are comparatively large and heavy and generally require electric servo motors, so that there is an increased demand with respect to time and energy. Particularly for systems suitable for field use, however, the energy consumption is a parameter which influences the period of use and reliability, so that the reduction thereof has

25
30

immediate advantages. Moreover, the frequent movement of relatively large and comparatively heavy parts leads to increased wear and requires wear-reducing or wear-resistant technical design of the components.

5 A further disadvantage is the necessity that each device has to have its own aligning means in order to align the axis of the measuring device with a target. Even if, for a specific surveying task, all targets are always within the acquisition range of the recording means, a movement of the device or at least of the two components, recording means and measuring device, must be effected for each measuring process.

10 A similar disadvantage arises in the case of automatic target tracking. If a target is actively illuminated by emitted radiation and is identified or tracked on the basis of the reflected radiation, in the case of devices of the prior art either the recording means have to be continuously moved or coordination of the movements of recording and illuminating means must be effected, which has the disadvantages already described.

SUMMARY

According to a first aspect of the present disclosure, there is provided an electronic display and control device for a geodetic measuring device having a radiation source for emission of a radiation beam for carrying out a measuring process, said electronic display and control device comprising:

recording means;

electronic display means for visual display of a measuring range acquired by said recording means;

25 input means for inputting data and for controlling the recording means and the measuring process;

at least one position mark provided by the display means, with the positioning of said position mark, defining a measuring point for three dimensional surveying; and

alignment means, said alignment means permitting variable alignment of the an emission direction of the radiation beam relative to an orientation of the recording means, the alignment means and the recording means, being arranged such that the radiation beam is at least partly coordinated with at least one optical component of the recording means, wherein the radiation beam is emitted by means of the optical component.

The present disclosure provides for a device in the form of an electronic display and control device for a measuring device or in the form of a measuring device which

The present disclosure provides for a device in the form of an electronic display and control device for a measuring device or in the form of a measuring device which typically reduces the movements required for measurement or the time and energy required therefor.

5

Additionally, the present disclosure may reduce the complexity of the design of the opto-electronic display and control device or of a measuring device of the generic type.

10

Also, the present disclosure could reduce the size of an electronic display and control device or of a measuring device of the generic type.

15

The present disclosure also may provide the possibility for target tracking with active illumination within the acquisition range of a measuring device without changing the field of view.

20

The invention is based on the concept of effecting a movement of the beam required for measurement within the acquisition range of an optical system without requiring an otherwise necessary movement of the entire optical system or relatively large components for this purpose. This is permitted by the use of optical components of the electronic recording means for the emission of the radiation beam. By means of the radiation emitted via the optical system of the recording means, it is possible in principle to survey all targets acquired and shown in the display, without having to move the optical axis of the recording means or a further independent component of the measuring device. The recording means refer to the devices for image production, which are used for establishing the target point for a measuring point. The detectors required for carrying out the measurement can also be

25

installed in further measuring devices so that, for example, fixing and illumination of a target by means of radiation is effected by a measuring device having an electronic display and control device according to
5 the invention, but the measurement is carried out by one or more further devices. In the following description by way of example, it is to be assumed, unless stated otherwise, that all components required for the measuring process are integrated in one
10 measuring device.

The invention thus relates in the wider sense to all measuring devices which are optically aligned with measuring points by alignment means to be handled
15 directly by a person.

The term "geodetic measuring device" is always to be understood in this context as meaning generally a measuring instrument which has devices for measuring or
20 checking data with a three-dimensional reference. In particular, this relates to the measurement of distance and/or direction or angles to a reference or measuring point. In addition, however, further apparatuses, for example components of satellite-supported position
25 determination (for example GPS, GLONASS or GALILEO) may be present, which can be used for supplementary measurements or data recording. In particular, such a geodetic measuring device is to be understood here as meaning theodolites and also so-called total stations
30 in the form of tacheometers with electronic angle measurement and electro-optical distance measuring device. The invention is also suitable for use in specialized devices having similar functions, for

example in military aiming circles or in the industrial monitoring of structures or processes; these systems are hereby likewise covered by the term "geodetic measuring device".

5

The image of a measuring range to be acquired and of measuring points to be sighted is focused via an optical system on electronic recording means and the image is visualized by display means. The rough
10 alignment of the measuring device or of the theodolite can now be effected by the positioning of a position mark on a screen. This position mark can be moved by the various devices, as are customary, for example, also in the computer sector for controlling screen
15 pointers. Depending on the mode chosen, tracking or alignment of the entire measuring device and/or the implementation, according to the invention, of a measuring process to the point defined by the position mark can be effected by movement of the position mark.

20

For example, it is possible to establish various measuring points which are then automatically moved away after completion of the input, or a measuring process for the parameters set in each case and to be
25 recorded is carried out directly to the actual point by positioning of the position mark.

30

The data and results of the measuring process can be displayed on the screen. This display is possible in the form of an overlaid text or in separate display fields. The latter may be in the form of separate parts of the screen which represent, for example, enlarged image sections or reference points with which an

alignment is to be effected.

The use of a touch-sensitive flat screen moreover makes it possible to dispense with special input means, so that the display and input means can be made compact and modular. A further possibility for realizing the display and input means consists in linking devices which can also be used for other applications. For example, it is possible to make use of further additional functions via an interface with communication networks or the use of a standard computer, in particular of a portable laptop or notebook. By using computers, additional, optionally universally applicable software can be employed. Moreover, recorded measured data can immediately be stored in the available memories and, after disconnection from the geodetic measuring device, can also be used in other applications. These advantages can be combined with an internet link, permitting additional data transmission or remote control.

The implemented division of the telescope provided to date with a direct view into recording and display means makes it possible for the user to assume a convenient, economically advantageous position regardless of the alignment of the recording means. Furthermore, a measuring device can be positioned in regions which have not been usable to date, for example in corners or narrow passages.

30

If the display and input means have a modular design, they can be structurally separated from the actual geodetic measuring device. A link to the geodetic

measuring device, which now substantially comprises only a housing and the components of the objective with sensor elements together with associated control components, can be produced by communication means, for example wire or radio connections. In this context, wire connections are always to be understood below as meaning all flexible communication connections which serve for the transmission of data, but in particular fibre optic and copper cables.

10

This division now permits the control of a large number of geodetic measuring devices as pure sensor units by means of a central control and evaluation unit. The latter can be protected from the weather, for example can be housed in a vehicle. In addition to the advantages for device and operator, the transfer of the load to a vehicle also permits the use of further additional components which, if mounted on the individual measuring devices, would prohibitively increase its weight. The use of a plurality of sensor units permits simplified, simultaneous measurements to common or different points, alignment of the geodetic measuring devices with one another or a successive use in which only a part of the sensor units is ever used for measurement while the other part is transferred to other locations. The display of the measuring ranges of simultaneously used sensor units can be effected in succession on the same screen or simultaneously on a screen in separate display areas, for example using the window or split screen technique.

25

30

By means of the electronic display, derivation of the horizontal and vertical angles to a target point as

shown on the display and selected by the position mark is possible without problems. Using these coordinates, the beam of the measuring device is guided to the target point with unchanged alignment of the recording means. In one embodiment, the insertion of the beam in the emission direction is effected before the objective of the recording means, so that the optical components associated therewith are also utilized by the radiation to be emitted. By using a common objective, the number of housing openings and of lenses can be reduced, which contributes to the structural simplification.

The required influencing of the beam can in principle be effected by a movement of the radiation source in the case of a fixed optical system or by movement or change of optical components in the case of a fixed radiation source. Moreover, however, radiation source and optical component can also be simultaneously moved according to the invention.

Suitable means for moving the radiation source are available, for example, in the form of piezoelements, electrostatically adjustable actuators or miniaturized motors. The influencing of the radiation beam by movement or change of the optical components can be effected in a variety of ways. Firstly, it is possible in principle to use the same elements as can also be used for movement of the radiation source. Secondly, it is also possible to change the optical properties of that region of an optical component which is affected by the radiation beam. One possibility for this consists in changing the angle of a reflective surface, which can be effected by tilting and rotating a mirror,

turning a rotatable double wedge or deforming a surface. Deformable mirror surfaces in the form of so-called continuous membrane deformable mirrors (CMDM) are disclosed, for example, in the patent US 6,384,952.

5

The electronic display and control device according to the invention, a measuring device according to the invention and a geodetic surveying system are described in detail below, purely by way of example, with
10 reference to embodiments shown schematically in the drawing. Specifically,

Fig. 1 shows the diagram of the components of an electronic display and control device
15 according to the invention;

Fig. 2 shows a first realization form of the alignment means according to the invention, in which the radiation source is designed to
20 be movable;

Fig. 3 shows a second realization form of the alignment means according to the invention, in which the emission direction of the radiation beam can be influenced by a movable
25 mirror;

Fig. 4 shows a third realization form of the alignment means according to the invention, in which the emission direction of the radiation beam can be influenced by a double
30 wedge;

- 5
Fig. 5 shows a fourth realization form of the alignment means according to the invention, in which the radiation source is designed to be movable and can be checked via a calibration control device;
- 10
Fig. 6 shows a diagram of a geodetic measuring device according to the invention, with separation of sensor unit and processing unit;
- 15
Fig. 7 shows the diagram of the cooperation, according to the invention, of position mark and radiation beam in the representation of a flat screen;
- 20
Fig. 8 shows the diagram of the cooperation, according to the invention, of position mark and radiation beam in the surveying of two targets using a theodolite;
- 25
Fig. 9 shows the diagram of the use of a geodetic surveying system according to the invention, comprising a plurality of geodetic measuring devices for successive surveying;
- 30
Fig. 10 shows the diagram of a first embodiment of the integration of transmitter and receiver on a support element;
- Fig. 11 shows the diagram of an embodiment having a fixed position of transmitter and receiver;

Fig. 12 shows the diagram of a second embodiment of the integration of transmitter and receiver on a support element and

5 Fig. 13 shows the diagram of a third embodiment of the integration of transmitter and receiver on a support element and an additional internal optical focusing of the radiation beam onto the recording device.

10

Fig. 1 shows the diagrammatic representation of the components of an electronic display and control device according to the invention, as may be used, for example, for the alignment of various types of
15 measuring devices and for the recording of measured data. Objective part 1a, together with an electronic recording device 1b, forms the recording means 1 required for the measuring process. The direct view for the human eye is replaced by suitable means for image
20 recording, for example a video or CCD camera. In addition to constructional advantages, these electronic means also permit selective or extended use of spectral ranges which are not directly accessible to the human eye. In the embodiment shown here by way of example, a
25 radiation source 1c and alignment means 1d are additionally integrated in the recording means 1, so that parts of the recording means 1 can be used for the beam paths of both recording device 1b and the radiation source 1c.

30

The recording means 1 shown can moreover have further instruments with an at least partly identical beam path or in coaxial arrangement. The omission of a direct

view results in constructional advantages through the reduced space requirement and the fact that optical image inversion is no longer necessary, as well as the now omitted restrictions with regard to the human eye, for example through the necessity of eye protection in the case of laser radiation.

The recording means 1 are connected directly to a display unit 2 which is pivotable relative to said recording means about a horizontal axis A and holds suitable display means. A section of the measuring range captured by the recording means 1 is shown on a screen 3 integrated in the display unit 2, as display means whose image is shown separately and rotated here for the sake of better clarity. The input of data for control of the recording means 1 with the display unit 2 and of the measuring process is effected, for example, via a keyboard 4 as input means. Alternatively or in addition, however, other input or control means, for example a joystick or trackball or other movement-sensitive devices can also be used. The keyboard 4 is connected to the display unit 2 via a cable 5. However, another possibility for connection comprises wireless communication, for example by using remote infrared or radio operation. The data relating to the measuring process and for the control thereof are input via the keyboard 4. For example, consecutive numbers, the current project designation or the user identification can be input for the measurements as background data of the measuring process. For the evaluation of the data acquired by the measuring process, it is possible to use an electronic computer with memory devices which are integrated, for example, structurally in the

housing of the keyboard 4.

The measuring process can moreover be directly controlled via the keyboard 4 by inputting the necessary commands, for example by positioning a cursor. By suitable input or control means, the recording means 1 are then roughly aligned and adjusted so that intended measuring processes can be carried out. Generally known means, such as, for example, servo motors or other actuators, can be used for control. If target points are located within the acquisition range of the recording means 1, it is possible, according to the invention, to dispense with a movement of the recording means 1. The target points are now surveyed by influencing the radiation beam S emitted by the radiation source 1c by the alignment means 1d, with unchanged alignment of the recording means 1, so that said beam captures the target point and a measurement is permitted.

20

Various embodiments of the invention which are suitable for uses in a theodolite or another geodetic measuring device are shown in Fig. 2-5, but not definitively.

25

Fig. 2 schematically shows a first realization form of the alignment means according to the invention in which the radiation source is designed to be movable. The recording means include, as substantial components, a recording device 1b onto which a measuring range is focused via an objective lens 6 and a focusing element 6'. Here, the objective lens 6 describes a suitable objective which may also be composed of a plurality of optical components. Equally, the focusing element 6' is

30

shown here purely by way of example as being present behind the objective lens 6. However, such an element can also equally be arranged at another point in the beam path, in particular in the objective. The focusing element 6' can be formed or can be controlled and moved, for example, as an autofocus system or as a precise refocusing element. A deflecting mirror element 7 is present in the beam path of this recording means, which is defined here by the optical axis B. The radiation which is emitted by a laser diode 8 as radiation source is emitted via this deflecting mirror element 7 and the subsequent objective lens 6 in the form of a radiation beam. In the case of fixed positioning of objective lens 6, the emission direction of the radiation can now be controlled by a movement of the laser diode 8, preferably in a plane. Such a movement can be effected by suitable miniaturized actuators or servo elements, such as, for example, piezoelectric elements, as alignment means 9. The alignment of the radiation beam with a target point can now be effected by movement of the laser diode 8 with unchanged alignment of the optical axis B. Alternatively or in addition to the movement in a plane, the laser diode 8 can also be tilted so that the angle relative to the deflecting mirror element 7 is varied for aligning the radiation beam. The radiation to be emitted and the recording device 1b thus use the objective lens 6 as a common optical component.

A second realization form of the alignment means according to the invention, in which the emission direction of the radiation beam can be influenced by a movable mirror as alignment means 9', is shown in

Fig. 3. The recording means once again have an objective lens 6, a focusing element 6' and a recording device 1b. In this embodiment, however, the laser diode 8 is fixed, whereas the mirror element as alignment means 9' is designed so as to be rotatable and tiltable. As a result of the movement of the mirror element, the alignment of the emitted radiation beam relative to the optical axis B can now be influenced and controlled. Suitable micropositionable mirror elements are available, for example, in the form of mirrors which can be inclined electrostatically relative to two axes. Instead of a rotatable and/or tiltable mirror, deformable optical elements, such as, for example, deformable mirror surfaces in the form of so-called continuous membrane deformable mirrors (CMDM), can also be mounted in the same place.

Fig. 4 describes a third realization form of the alignment means according to the invention, in which the emission direction of the radiation beam can be influenced by a double wedge. Once again, the recording means have an objective lens 6, a focusing element 6' and a recording device 1b. The deflection mirror element 7 and the laser diode 8 are both fixed. Two wedges rotatable relative to one another and in the form of an optically effective double wedge now serve as an alignment means 9''. By positioning the two wedges relative to one another, the radiation is influenced by refraction in a manner known per se and the radiation beam is thus deflected and is aligned with a target point. As an alternative to the positioning shown, between deflection mirror 7 and laser diode 8, the double wedge can also be mounted at

other locations in the beam path. A possible position before the objective lens 6 is shown by means of dashed lines as a further example.

5 Fig. 5 shows a fourth realization form according to the invention, in which the radiation source is designed to be movable and can be checked with respect to its zero position by means of a calibration control device. The recording means have an objective lens 6, a focusing
10 element 6' and a recording device 1b, the focusing element 6' being arranged directly after the objective lens 6. The radiation emitted by the laser diode 8 which can be positioned by servo elements as alignment means 9 passes via a lens 1g and a deflection mirror
15 element 7' designed as a beam splitter and is both emitted by the focusing element 6' and the objective lens 6 and guided by means of a further lens 1f onto an image sensor 1e. This embodiment thus constitutes a modification of the embodiment shown in Fig. 2. By
20 means of the additional image sensor 1e, the positioning of the laser diode 8 can be calibrated, or checked with regard to the calibration, independently of the detection via the recording device 1b.

25 Fig. 6 shows an embodiment, according to the invention, of a geodetic measuring device 12 having a modular touch-sensitive flat screen 2' as a display unit, in which electronic evaluation means are also integrated. The geodetic measuring device 12 is connected to the
30 flat screen 2' by a wireless communication link so that the two components can also be used a great distance apart. The recording means 1' or the recording means of the geodetic measuring device 12 which influence the

radiation beam are remote controlled by the commands transmitted via flat screen 2'. The acquired measuring range 11 is in turn transmitted to the flat screen 2' and displayed there. The recording means 1' can be
5 moved by orientation means 10 so that the acquired measuring range 11 can be changed. If the measuring range includes all target points to be surveyed, for example in the area of monitoring of structures, or if, for other reasons, it is intended to dispense with a
10 change of the acquired measuring range 11, for example for achieving as simple a device design as possible, it is also possible alternatively to realize a measuring device according to the invention without orientation means 10.

15

An integrating embodiment is the combination of various components in a touch-sensitive flat screen 2' as a display unit, shown in Fig. 7. For example, the functions of screen 3 and keyboard can be combined in
20 this element. The flat screen 2' has a screen 3 as display means, which has subdivisions into further display fields 3b. For example, enlarged sections of the measuring range or, as shown here, data of the measuring process can be shown in these display fields
25 3b. The optical axis B of the recording means is shown in the centre of the screen 3. Said axis defines the midpoint of the display of the acquired measuring range.

30 The measuring process is controlled by means of a movable position mark 3a which can be moved within the screen 3. In this embodiment of the touch-sensitive flat screen 2', touching with the finger or an object

is sufficient to enable the position mark 3a to be moved. The radiation beam can be moved within the acquired measuring range by the alignment means so that said beam is aligned with a target point established by the position mark 3a. In the display on the screen 3, this corresponds to a movement of the position 3c of the radiation beam to the position mark 3a.

Depending on the specific design or chosen mode, a measuring process can be initiated simply by moving the position mark 3a. In the scenery shown, a movement of the position mark 3a from the optical axis B to the top of one of the trees as an end position would thus automatically initiate a measurement of distance and direction to this target point thus established. This measurement is now effected with fixed optical axis by a movement of the radiation beam to the target point and a measuring process associated therewith. In addition, for example, further data can be recorded. For example, it is possible to measure or to calculate and to specify the angle and the absolute difference in height between optical axis B or another reference point and the target point. Alternatively, a path comprising a plurality of target points, which is automatically travelled after a start command, can also be established by the movement of the position mark 3a. For this purpose, the radiation beam is aligned successively with the target points by the alignment means and in each case a measuring process is carried out. In the display, position 3c of the radiation beam thus travels in succession to the points selected by the position mark 3a. In principle, however, movements of the recording means can also be associated with the

movement of the radiation beam within the measuring range. For example, coordinates of a point to be surveyed can be input via a keyboard. If this target point is located outside the acquired measuring range, the recording means are thus roughly aligned with this target point, it not being necessary for the optical axis B to point at this point. The surveying is then effected by a subsequent and exact alignment of the radiation beam with this target point, which, after the recording means have been set up, is now located within the measuring range.

Fig. 8 shows the cooperation, according to the invention, of position mark and radiation beam in the surveying of two targets using a theodolite as geodetic measuring device 12. By means of the position mark 3a, two target points which are defined by the actual position of the position mark 3a and an earlier position 3a' are established within the measuring range 11 established by the alignment of the optical axis with a point. Although the optical axis B of the recording means remains aligned with the original point in the middle of the measuring range 11, a measuring process to the selected target points within the measuring range 11 is effected in each case as a result of an alignment of the radiation beam S.

The use of a plurality of geodetic measuring devices 12, 12' designed in this manner in a geodetic surveying system according to the invention is shown schematically in Fig. 9. In a successive method, a geodetic survey is carried out alternately with the geodetic measuring devices 12, 12'. The elements

required for operating the measuring devices 12 and 12' can be designed in the form of module components in which input means and/or display means are integrated. An example of the integration of input and display means in a common module component is a touch-sensitive flat screen 2'. It is also possible, for example, to use further module components which have only screens as display means and serve for tracking and monitoring the ongoing measuring process. While there is radio contact between such a touch-sensitive flat screen 2' as a modular input means and the geodetic measuring device 12 and a measurement is carried out, the second geodetic measuring device 12' or even further or other sensor units can be brought to a new reference point 13. In this system according to the invention, the geodetic measuring devices 12, 12' or even other, similarly designed sensor units can be kept simple and hence economical by dispensing with separate display and input means. Only one person, who can be located remotely and protected from weather influences, is required for operating the input means. Owing to the successive use, which, in view of the simple transfer of the sensor units, involves no special training requirements for the personnel, and the remote-controlled fine positioning possible via an integrated plumb line, surveys can be carried out more quickly and hence more economically than in the past.

Because the alignment of the radiation beam is variable relative to the optical axis, there is also a need for tracking or adapting the alignment of the receiving device. In principle, emission and reception of the radiation beam in the case of the device according to

the invention can be designed to be independent of one another. For example, the receiving device can be electronically controlled and moved by a circuit or a computer so that it takes into account the receiving
5 conditions resulting from the alignment of the radiation beam. However, for reasons of the technical complexity and of the design of the device with regard to size, weight and energy consumption, it is expedient either to fix a position of radiation source and
10 receiving device and directly to manipulate the alignments of emitted and received radiation beam or to mount radiation source and receiving device on a common support element and to move this support element. Various examples of embodiments of these two
15 alternatives are shown in Figures 10 to 13.

Fig. 10 shows a first embodiment of the integration of a laser diode 8 as a radiation source and of a receiving device 14 on a common support element 15. The
20 movable laser diode 8 emits radiation onto a first inclined surface of a double-sided deflection mirror element 7a, from which this radiation is emitted via an objective lens 6 as a radiation beam. The radiation received again via the objective lens 6 after
25 reflection of the radiation beam is guided from a back-reflecting mirror element 7b onto the second surface of the deflection mirror element 7a and from there to the receiving device 14, which, for example, may consist of a photodiode. Both laser diode 8 and receiving diodes
30 14 are held by a common support element 15 as alignment means and can be moved in the same manner by said alignment means, laser diode 8 and receiving device 14 being arranged in this example with their emission

direction and receiving direction opposite to one another. Owing to the movement of the same kind, the positioning of radiation source and receiving device 14 was effected in a manner tailored to one another, with the result that no second control device with the associated actuators is required. The focusing is effected in this embodiment by means of an adjustable focusing element 6', which is arranged behind the objective lens 6 in the beam path.

10

Fig. 11 shows an alternative embodiment comprising fixed positioning of laser diode 8 and receiving device 14. The laser diode 8 in a fixed position emits radiation via a deflection mirror element 7 onto a first inclined surface of a double-sided deflection mirror element 7a, from which this radiation is emitted via an objective lens 6 with subsequent mutually rotatable wedges as alignment means 9''. This embodiment thus resembles the version described in Fig. 4. The radiation received again via the objective lens 6 after reflection is guided by a back-reflecting mirror element 7b onto the second surface of the deflection mirror element 7a and from there to the receiving device 14 in a fixed position.

25

Fig. 12 shows the diagram of a second embodiment of the integration of radiation source and receiving device 14 on a support element 15 as integrated transmission and receiving unit 16. In this embodiment, the radiation emitted by the laser diode 8 which can be positioned by a movement by means of support element 15' is emitted via the deflection mirror element 7c, mounted before the objective lens 6a, through a cover element 17 as a

30

radiation beam. The radiation is guided within the transmission and receiving unit 16 through a lens 1h onto a lens 1i in a fixed position relative to the deflection mirror element 7c. This beam path results in
5 an emission of the radiation bundle at an angle to the optical axis B, which emission is dependent on the positioning of the transmission and receiving unit 16. The radiation received via the objective lens 6' after reflection is guided by a back-reflecting mirror
10 element 7b onto the deflection mirror element 7d and from there to the receiving device 14 integrated in the transmission and receiving unit 16. Since the radiation beam is not emitted through the objective lens 6', image inversion relative to the emission direction
15 results on reception of the radiation which takes place through the objective lens 6'. Suitable positioning of laser diode 8 and receiving device 14 by displacement in the same direction by means of the transmission and receiving unit 16 can thus be achieved.

20

The diagram of a third embodiment of the integration of radiation source and receiving device 14 on a support element 15 is shown in Fig. 13. Here, owing to internal optical focusing of the radiation beam onto the
25 recording device 1b, the necessity of displaying the position of the radiation beam within the acquisition range by an artificially produced point is superfluous. The radiation produced by the laser diode 8 via the lenses 1h and 1i is split by means of a deflection
30 mirror element 7'' in the form of a beam splitter into a first and a second part-beam, and the first part-beam is emitted through an objective lens 6 as a radiation beam. The second part-beam is guided via a

retroreflector 18, with which a shutter 19 for avoidance of cross-talk can be coordinated, once again onto the deflection mirror element 7'' and from there through a lens 6b onto a second deflection mirror element 7' which is in the form of a beam splitter and where a third and fourth part-beam are produced. This deflection mirror element 7' allows the third part-beam of the radiation produced by the laser diode 8 to strike the recording device 1b so that the point of incidence of this radiation corresponds to the position of the radiation beam within the acquisition range. The fourth part-beam is guided onto the receiving device 14. By suitable positioning of the transmission and receiving unit 16', the laser diode 8 and receiving device 14 mounted on a support element 15'' can be moved in the same direction and thus aligned.

Of course, the figures presented show one of many embodiments, and the person skilled in the art can derive alternative realization forms, for example with the use of other optical components or sensor units, different beam paths or other alignment means, operating elements and input elements. In particular, the adjustment of radiation source and receiving device can also be effected by other displacement methods not explicitly shown here, for example by rotation or inclinations about a plurality of axes. Equally, the device according to the invention can be applied to similar measuring devices having a different range of functions, such as, for example, total stations or straight forward distance-measuring devices, or to measuring devices having similar but specialized

functions, such as, for example, components of military aiming circle or industrial monitoring systems.

The claims defining the invention are as follows:

1. An electronic display and control device for a geodetic measuring device having a radiation source for emission of a radiation beam for carrying out a measuring process, said electronic display and control device comprising:
- 5 recording means;
- electronic display means for visual display of a measuring range acquired by said recording means;
- input means for inputting data and for controlling the recording means and the
- 10 measuring process;
- at least one position mark provided by the display means, with the positioning of said position mark, defining a measuring point for three dimensional surveying; and
- alignment means, said alignment means permitting variable alignment of an emission direction of the radiation beam relative to an orientation of the recording means,
- 15 the alignment means and the recording means being arranged such that the radiation beam is at least partly coordinated with at least one optical component of the recording means, wherein the radiation beam is emitted by means of the optical component.
2. The electronic display and control device according to claim 1, wherein the
- 20 alignment means are arranged so that the alignment of the radiation beam is effected in such a way that, in the display of the acquired measuring range, the position of the radiation beam is made to coincide with the position mark so that the radiation beam is utilized for carrying out the measuring process.
3. The electronic display and control device according to claim 1 or 2, wherein the
- 25 alignment means have at least one of the following means
- servo elements for two-dimensional movement of the radiation source,
 - a rotatable and/or tiltable reflecting surface,
 - a, preferably continuously, deformable reflecting surface,
 - a transmittive double wedge rotatable relative to one another.
- 30
4. The electronic display and control device according to any one of the preceding claims, wherein a calibration control device is present which has an image sensor which detects the emission direction of the radiation beam so that detection of the emission
- 35 direction of the radiation beam independently of the recording means takes place.

5 5. The electronic display and control device according to any one of the preceding claims, wherein the display means are arranged so that display of the radiation beam in the measuring range is effected by at least one pixel displayed in a distinguishable manner, which is effected either

- by calculation of the position of the radiation beam in the measuring range and electronic enhancement of the pixel coordinated with this position or

- by direct optical imaging of the radiation within the recording means.

10 6. The electronic display and control device according to any one of the preceding claims, wherein the position mark can be positioned by the input means within the visual display, preferably in discrete steps, in particular pixel by pixel.

15 7. The electronic display and control device according to any one of the preceding claims, wherein the input means and/or display means are designed so that, by the positioning of the position mark, at least a part of the measuring process is initiated, in particular

- the control of the recording means and/or
- the control of the alignment means is effected.

20 8. The electronic display and control device according to any one of the preceding claims, wherein the visual display of the acquired measuring range or of parts of the measuring range can be made smaller, can be made larger and/or can be changed in its resolution by the recording means and/or display means, in particular by a variation of
25 the, preferably electronic, assignment of the data of pixels of the recording means to pixels of the display means.

9. The electronic display and control device according to any one of the preceding claims, wherein the recording means comprise at least one of the following means

- 30
- CCD camera,
 - CMOS camera,
 - video camera,
 - low light level amplifier,
 - thermal imaging camera,
 - 35 - spectrally selective detector,

- spectral filter.

10. The electronic display and control device according to any one of the preceding claims, wherein the recording means have an autofocus system which is part of the objective or is positioned outside the objective in the beam path.

11. The electronic display and control device according to any one of the preceding claims, wherein the display means comprise at least one of the following means

- LCD display,
- cathode ray tube,
- flat screen,
- interface to communication networks,
- electronic computer with monitor, preferably portable laptop.

12. The electronic display and control device according to any one of the preceding claims, wherein the input means comprise at least one of the following means

- touch-sensitive screen,
- touch-sensitive input field,
- keyboard field,
- joystick,
- trackball,
- computer mouse,
- interface to communication networks,
- electronic computer with input device, preferably a portable laptop.

13. The electronic display and control device according to any one of the preceding claims, wherein the electronic display means and the input means are combined in one component, preferably a touch-sensitive flat screen.

14. The electronic display and control device according to any one of the preceding claims, wherein the recording means and the alignment means are in the form of an independent module and are connected to the other components via a wire connection or a radio link.

15. The electronic display and control device according to any one of the preceding claims, wherein at least one position mark is preferably a cross hair.

16. A geodetic measuring device, said geodetic measuring device comprising:
5 a radiation source for emission of a radiation beam for carrying out a measuring process;
a receiving device for acquiring radiation of the reflected radiation beam and converting this radiation into signals;
electronic evaluation means for evaluating the signals; and
10 an electronic display an control device according to any one of claims 1 to 15.

17. The geodetic measuring device according to claim 16, wherein orientation means for orienting the recording means relative to a measuring range.

15 18. The geodetic measuring device according to claim 17, wherein further input means for controlling the orientation means.

19. The geodetic measuring device according to any one of claims 16 to 18, wherein the electronic display and control device is designed so that, by positioning of the position
20 mark, determining at least one parameter of the measuring process,

- the fixing of a measuring point for three- dimensional surveying,
- the control of the recording means,
- the control of the alignment means and/or
- the control of the orientation means, is effected.

25 20. The geodetic measuring device according to any one of claims 17 to 19, wherein the radiation source and the receiving device are arranged on a movable support element.

21. The geodetic measuring device according to any one of claims 17 to 20, wherein
30 the radiation source, the receiving device and the alignment means are formed and arranged in such a way that both radiation emitted by the radiation source and radiation to be received by the receiving device are guided via the alignment means, in particular a transmittive double wedge rotatable relative to one another.

2003229660 01 Oct 2008

22. The geodetic measuring device according to any one of claims 17 to 21, wherein the orientation means have a device, in particular attachable device, for alignment of the geodetic measuring device relative to a reference point, preferably a triangulation point, in particular in association with a movement of the recording means from the orientation
5 necessary for acquisition of the measuring range into an orientation for detection of the reference point.

23. The geodetic measuring device according to any one of claims 16 to 22, wherein the input means and/or the display means are mounted so as to be movable independently
10 of an alignment of the geodetic measuring device, in particular pivotable about a horizontal axis.

24. A module component for a geodetic surveying system comprising integrated input means and/or display means of a geodetic measuring device according to any one of
15 claims 16 to 23, said module component being in the form of an independent module and means for establishing a wire connection or a radio link to the geodetic measuring device and optionally to at least one further geodetic measuring device.

25. A geodetic surveying system,
20 comprising at least two geodetic measuring devices according to any one of claims 16 to 23 and comprising at least one module component according to claim 24, the at least one module component being in the form of common input means and/or common display means for the at least two geodetic measuring devices, optionally with alternate use thereof.

26. An electronic display and control device for a geodetic measuring device having a radiation source for emission of a radiation beam for carrying out a measuring process, said electronic display and control device being substantially as herein before described with reference to any one of the embodiments, as that embodiment is shown in the
30 accompanying drawings.

DATED this Twenty-Ninth Day of September 2008

Leica Geosystems AG

Patent Attorneys for the Applicant

SPRUSON & FERGUSON

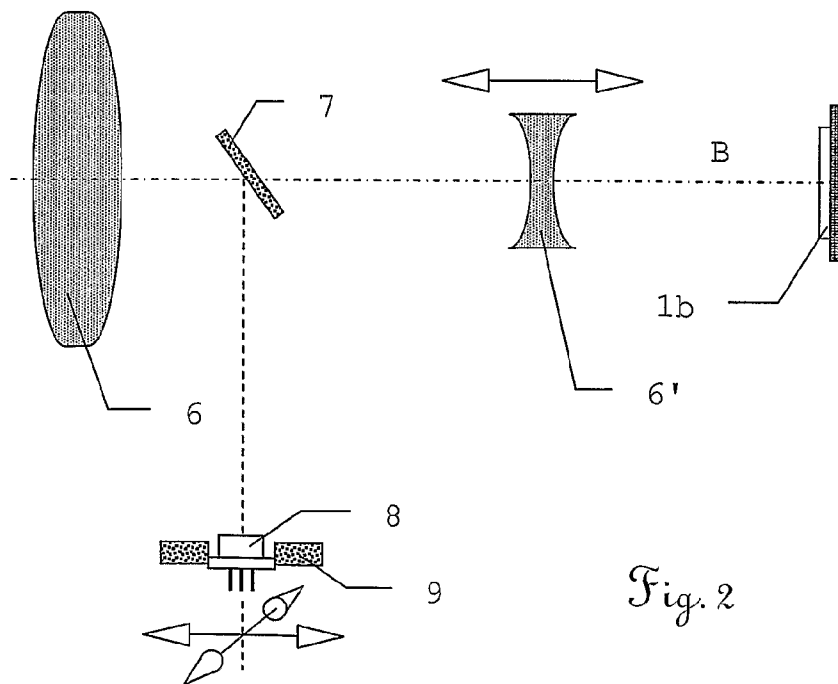
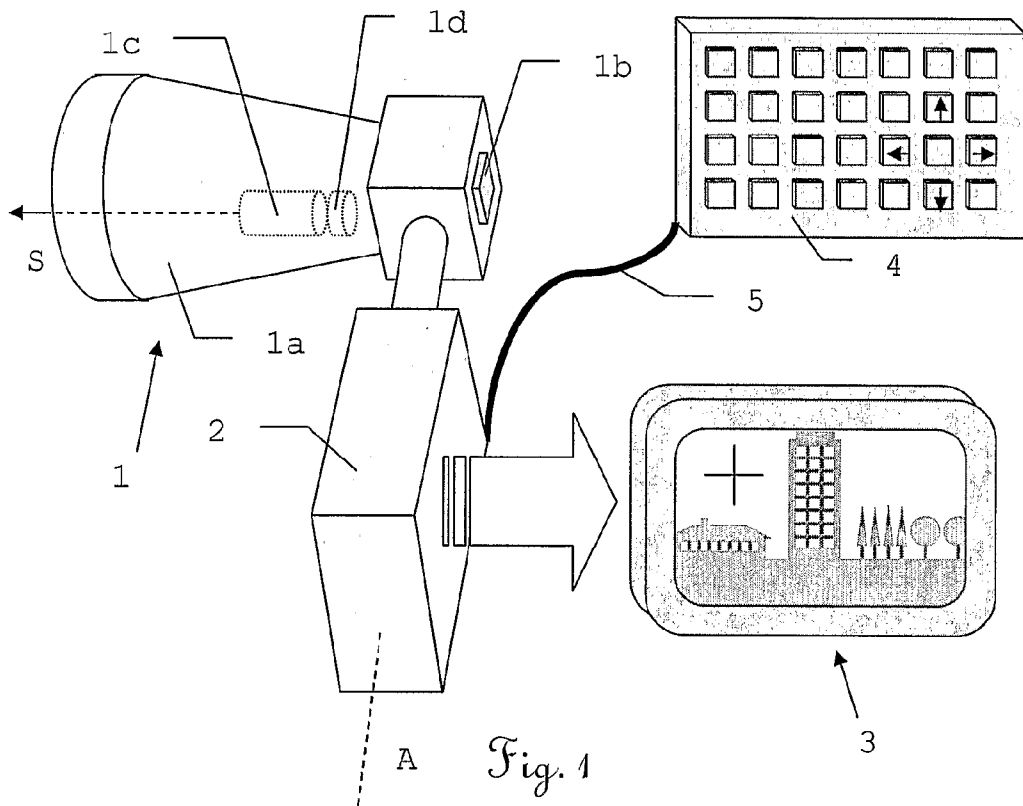

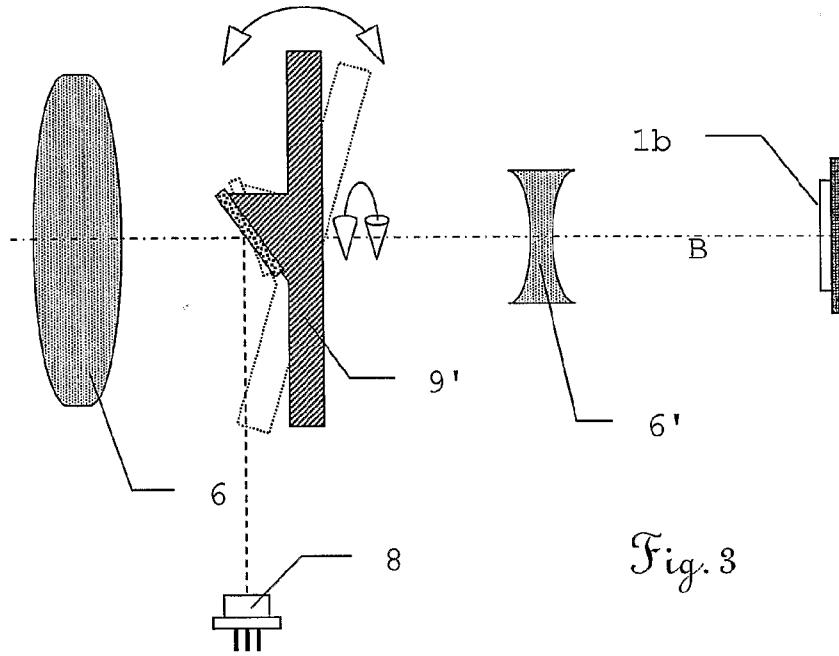

Fig. 3

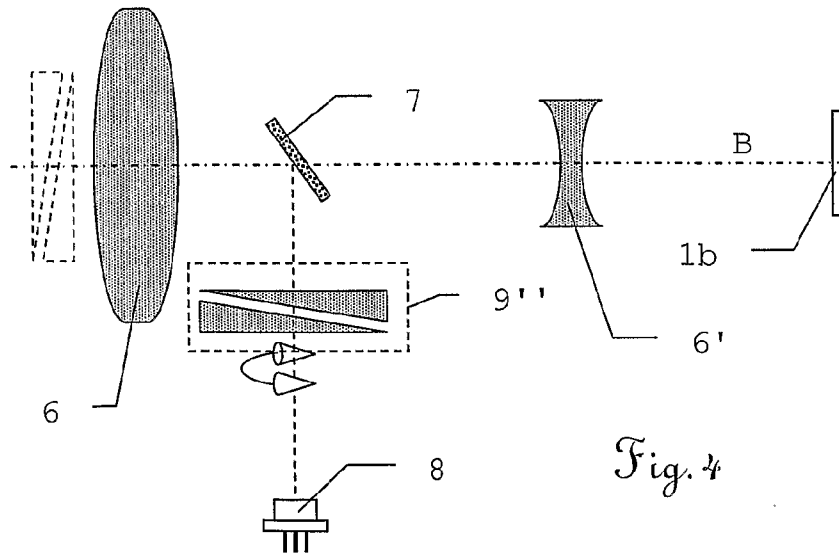
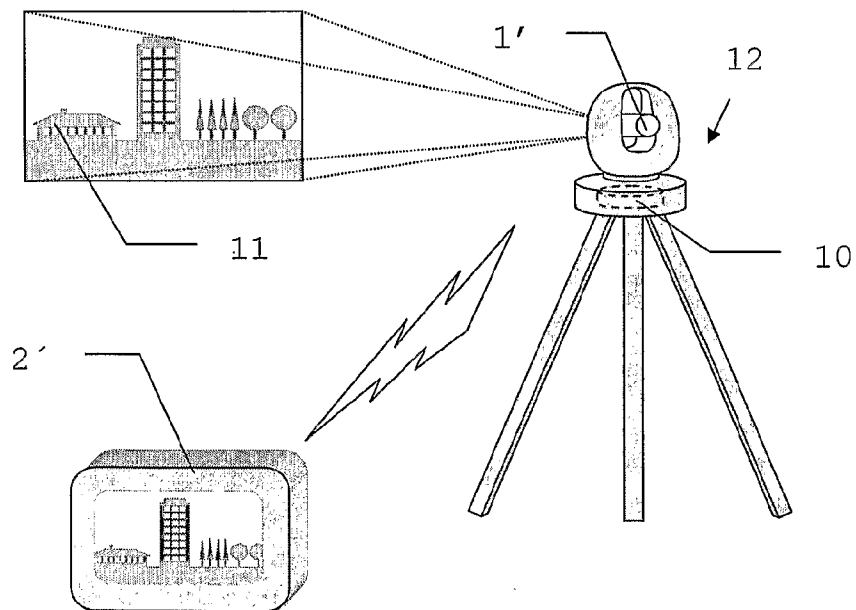
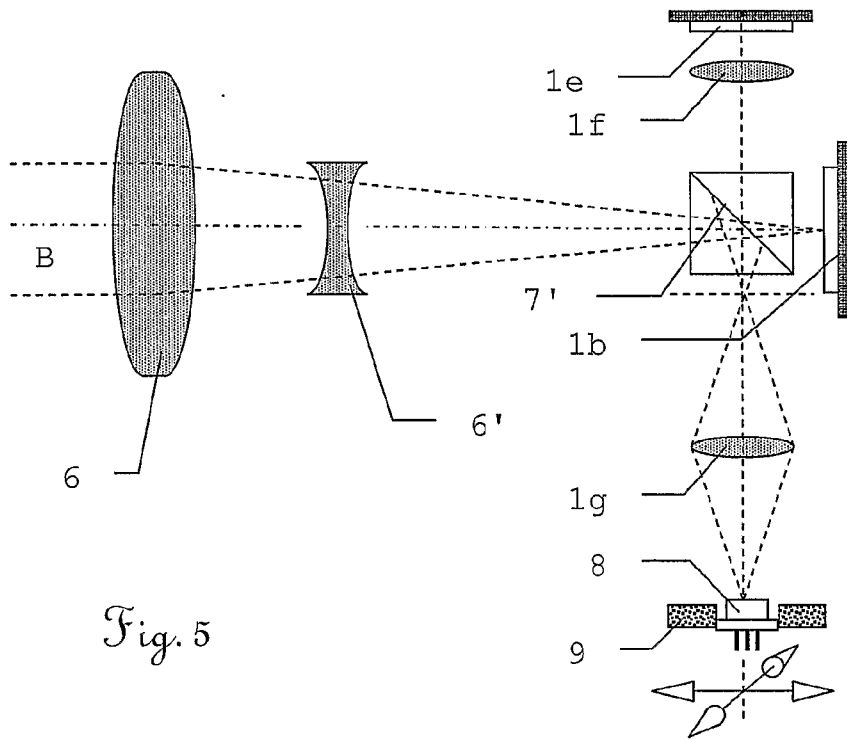

Fig. 4



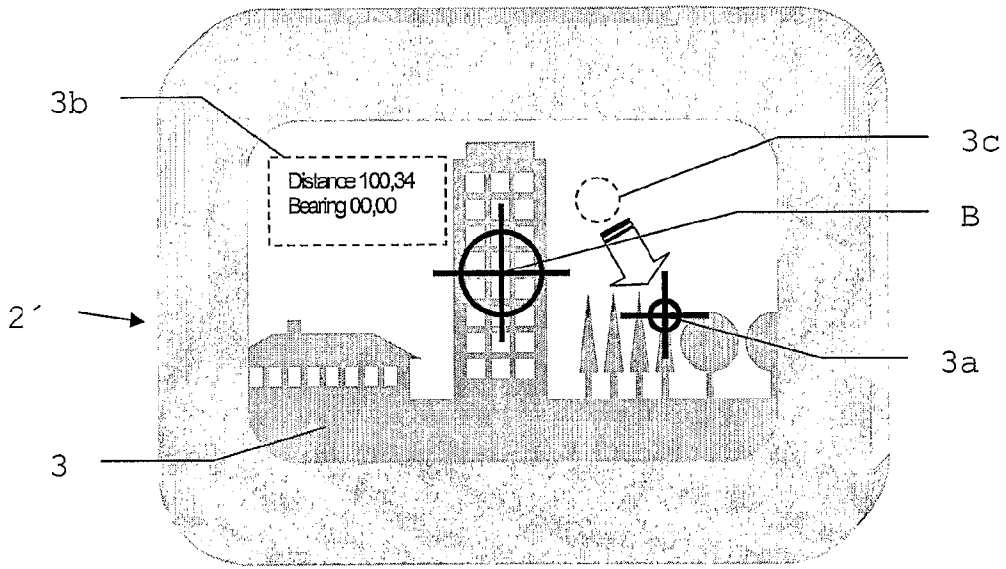

Fig. 7

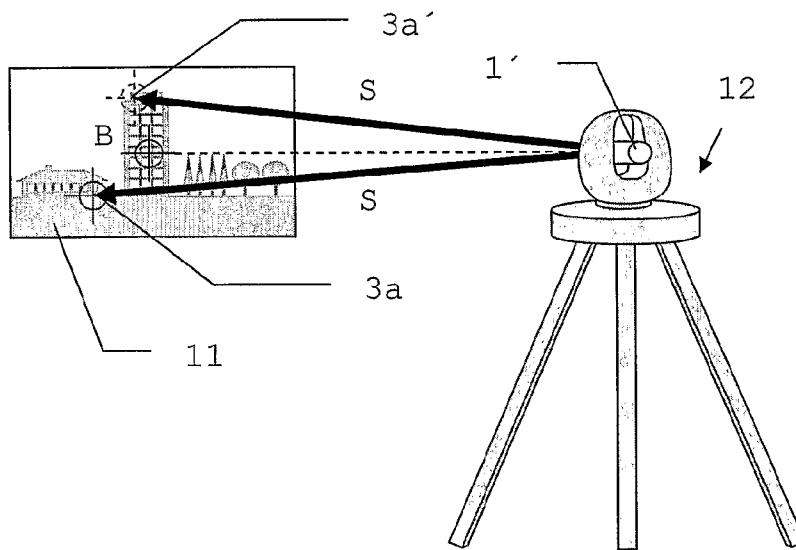

Fig. 8

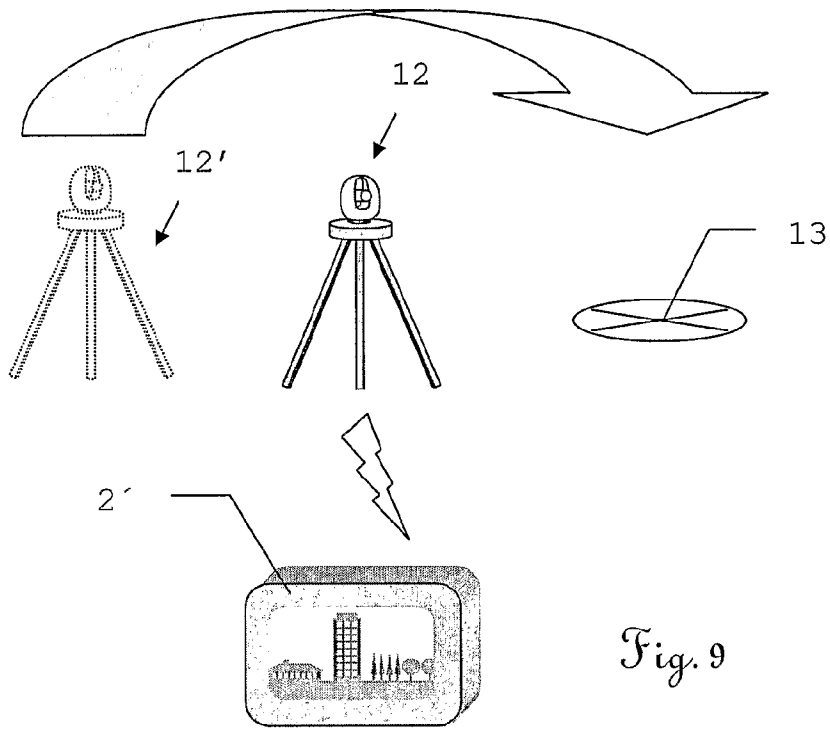

Fig. 9

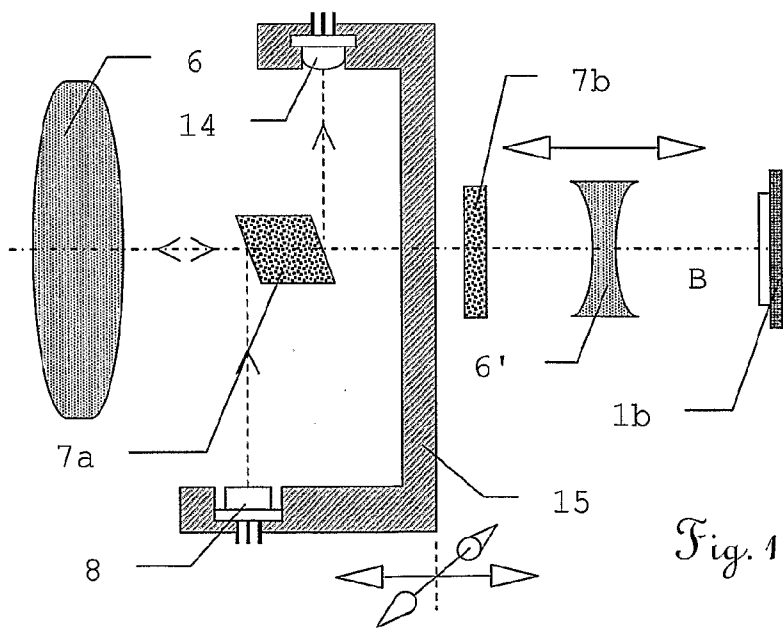

Fig. 10

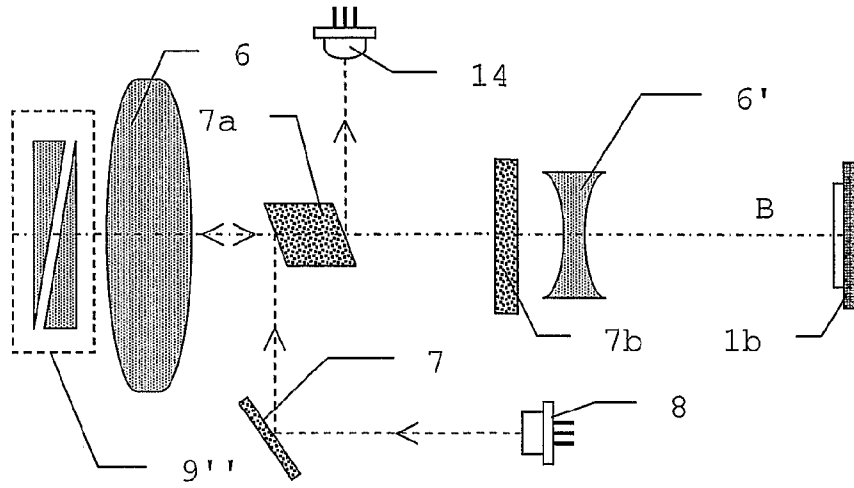

Fig. 11

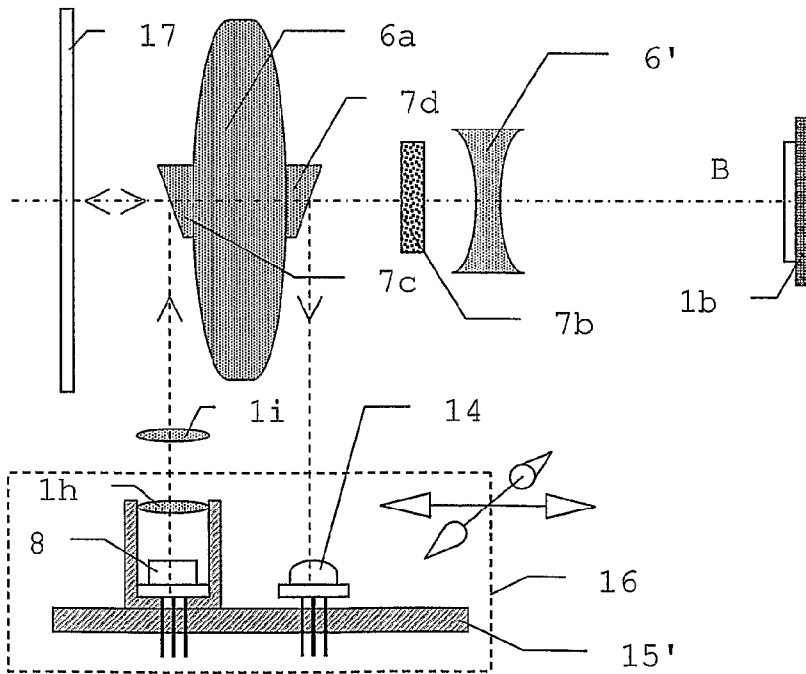

Fig. 12

7/7

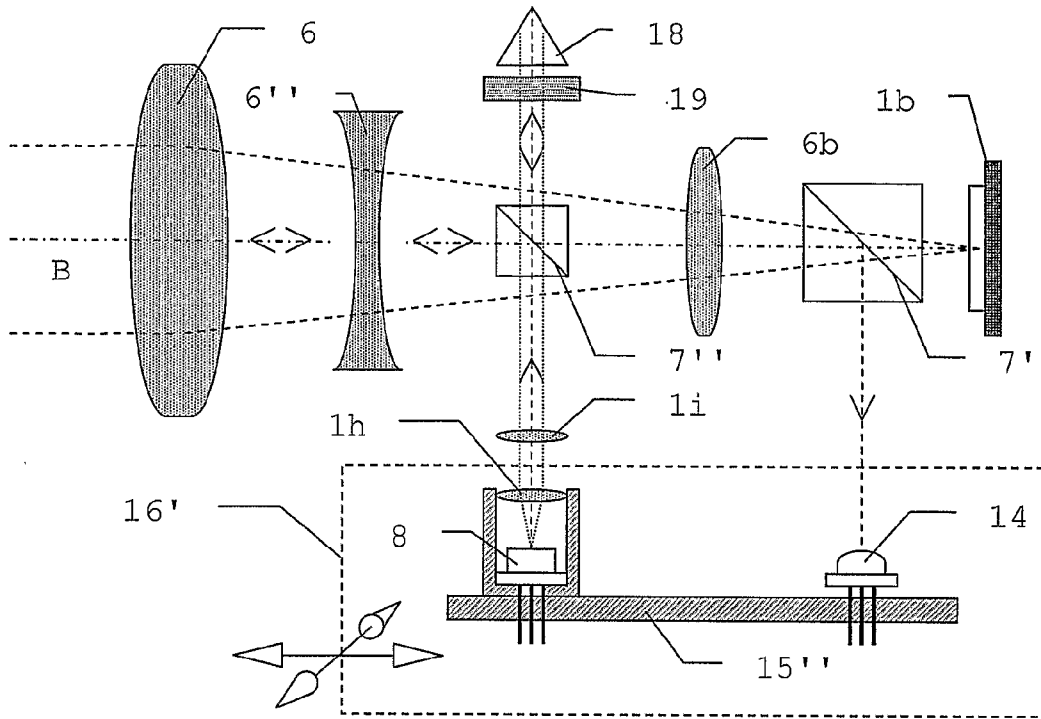

Fig. 13