

(19) World Intellectual Property Organization
International Bureau



(43) International Publication Date
22 February 2001 (22.02.2001)

PCT

(10) International Publication Number
WO 01/12941 A1

(51) International Patent Classification⁷: E06B 3/663

(21) International Application Number: PCT/US00/21558

(22) International Filing Date: 8 August 2000 (08.08.2000)

(25) Filing Language: English

(26) Publication Language: English

(30) Priority Data:
09/376,321 18 August 1999 (18.08.1999) US

(71) Applicant: GUARDIAN INDUSTRIES CORPORATION [US/US]; 2300 Harmon Road, Auburn Hills, MI 48326-1714 (US).

(72) Inventors: AGGAS, Steven, L.; 3387 Hooker Road, Pinckney, MI 48169 (US). VEERASAMY, Vijayen, S.; 22575 Maywood Court, Farmington Hills, MI 48335 (US).

(74) Agent: RHOA, Joseph, A.; Nixon & Vanderhye P.C., Suite 800, 1100 North Glebe Road, Arlington, VA 22201-4714 (US).

(81) Designated States (*national*): AE, AG, AL, AM, AT, AU, AZ, BA, BB, BG, BR, BY, BZ, CA, CH, CN, CR, CU, CZ, DE, DK, DM, DZ, EE, ES, FI, GB, GD, GE, GH, GM, HR, HU, ID, IL, IN, IS, JP, KE, KG, KP, KR, KZ, LC, LK, LR, LS, LT, LU, LV, MA, MD, MG, MK, MN, MW, MX, MZ, NO, NZ, PL, PT, RO, RU, SD, SE, SG, SI, SK, SL, TJ, TM, TR, TT, TZ, UA, UG, UZ, VN, YU, ZA, ZW.

(84) Designated States (*regional*): ARIPO patent (GH, GM, KE, LS, MW, MZ, SD, SL, SZ, TZ, UG, ZW), Eurasian patent (AM, AZ, BY, KG, KZ, MD, RU, TJ, TM), European patent (AT, BE, CH, CY, DE, DK, ES, FI, FR, GB, GR, IE, IT, LU, MC, NL, PT, SE), OAPI patent (BF, BJ, CF, CG, CI, CM, GA, GN, GW, ML, MR, NE, SN, TD, TG).

Published:
— With international search report.

For two-letter codes and other abbreviations, refer to the "Guidance Notes on Codes and Abbreviations" appearing at the beginning of each regular issue of the PCT Gazette.

(54) Title: VACUUM IG UNIT WITH SPACER/PILLAR GETTER

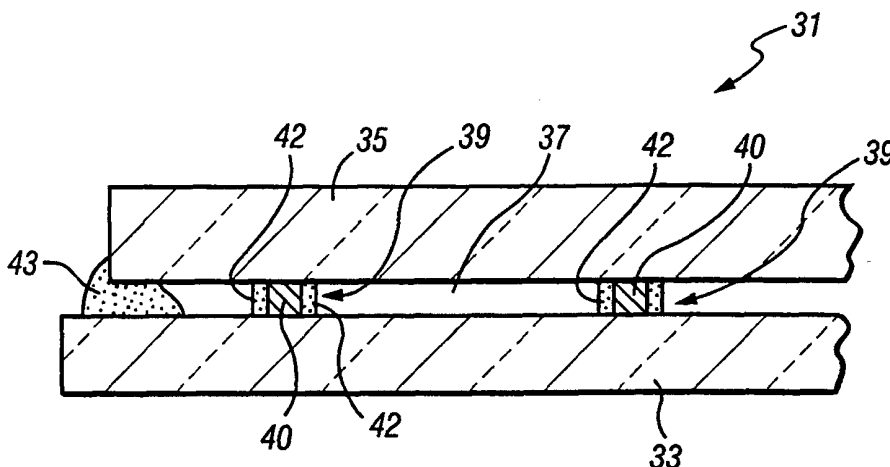

(57) Abstract: A vacuum insulating glass (IG) unit is provided with a plurality of spacers/pillars between opposing substrates. The spacers/pillars function (i) to support and space the substrates from one another, and (ii) as a getter to adsorb gas(es) located within the low pressure space between the substrates. Such spacers/pillars may be formed of one-piece getter inclusive material, or may be multi-piece including a getter coating.

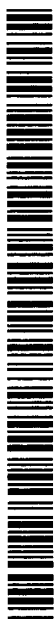

WO 01/12941 A1

VACUUM IG UNIT WITH SPACER/PILLAR GETTER

This invention relates to a vacuum insulating glass (IG) unit including at least one spacer/pillar with getter material(s), and a corresponding method of making the same.

5

RELATED APPLICATIONS

Commonly owned U.S. Serial Nos. 09/303,550, entitled "VACUUM IG PILLAR WITH DLC COATING" and filed May 3, 1999, and 09/348,281, entitled PERIPHERAL SEAL FOR VACUUM IG UNIT and filed July 7, 1999, are both hereby incorporated herein
10 by reference.

BACKGROUND OF THE INVENTION

Vacuum IG units are known in the art. For example, see U.S. Patent Nos. 4,683,154, 5,664,395, 5,657,607, 5,855,638, 5,891,536, and 5,902,652, the entire disclosures of which
15 are all hereby incorporated herein by reference.

Prior art Figures 1-2 illustrate conventional vacuum IG unit 1. Unit 1 includes two spaced apart sheets of glass 2 and 3 which enclose an evacuated or low pressure space therebetween. Glass sheets 2 and 3 are interconnected by

peripheral seal of fused solder 4 and an array of support spacers or pillars 5.

Pump out tube 8 is hermetically sealed by fused solder glass 9 to aperture 10 which passes from an interior surface of glass sheet 2 to the bottom of recess 11 in the exterior face of sheet 2. When sheets 2, 3 and peripheral/edge seal 4 are in place, prior to the tube being sealed, a vacuum is attached to tube 8 so that the interior cavity between sheets 2 and 3 can be vacuumed out or evacuated to create a low pressure area.

As shown in Figures 1-2, chemical getter 12 may be included within machined recess 13 in one of the glass sheets to counteract any rise in pressure due to out-gassing from the glass. Getters in vacuum IG units are also known as shown and/or described in U.S. Patent Nos. 4,683,154, 5,124,185, and 5,657,607, the disclosures of which are incorporated herein by reference.

While conventional getters discussed above can function in a satisfactory manner in different environments, they may suffer from processing problem(s) and/or high manufacturing cost requirements. For example, the getter in the Benson '154 patent requires a separate metal plate-like structure

between the sheets, which may not be considered aesthetically pleasing to some viewers. The getter of the Collins '607 patent requires machining a recess in one of the glass plates for getter placement.

5 It is apparent from the above, that there exists a need in the art for a vacuum IG unit having an improved getter(s), and corresponding method for making the same. There also exists a need in the art for a getter(s) inclusive vacuum IG unit that does not require machining of
10 a recess into one of the glass sheets for getter mounting. There exists a further need in the art for a vacuum IG unit which includes a structure that functions as both a getter and as a spacer/pillar. It is a purpose of this invention to fulfill any or all of the above listed needs in the art.
15 This invention will now be described with respect to certain embodiments thereof, accompanied by certain illustrations.

SUMMARY OF THE INVENTION

20 An object of this invention is to provide a vacuum IG unit including an improved getter(s).

Another object of this invention is to provide a vacuum IG window unit that includes a spacer/pillar that also functions as a getter.

Another object of this invention is to provide a getter
5 structure for a vacuum IG unit that does not require machining a recess into a glass sheet for separate getter mounting or placement.

Another object of this invention is to provide a method of making a getter/spacer (or getter/pillar) for a vacuum
10 IG unit, the method including the step of applying a getter powder(s) onto a humidified spacer core and thereafter substantially melting the getter powder (e.g. using microwaves or some other form of energy) so that the getter material(s) diffuses into and/or adheres to the spacer core.

15 Another object of this invention is to provide a spacer/pillar for a vacuum IG unit, where the spacer/pillar is made of or comprises a getter material.

Another object of this invention is to fulfill any or all of the above-listed objects.

20 Generally speaking, this invention fulfills any or all of the above described needs in the art by providing a thermally insulating glass panel comprising:

first and second spaced apart glass substrates defining
a low pressure space therebetween;

a seal interconnecting said first and second spaced
apart glass substrates so as to hermetically seal said low
5 pressure space between said substrates; and

an array of getter inclusive spacers disposed in said
low pressure space for maintaining separation of said first
and second glass substrates.

This invention further fulfills any or all of the above
10 described needs in the art by providing a method of
maintaining vacuum in a low pressure space between first and
second substrates, said method comprising the steps of:

providing a plurality of getter spacers in the low
pressure space between the first and second substrates to
15 support the substrates and space the substrates from one
another; and

the spacers adsorbing gas present in the low pressure
space to maintain vacuum in the low pressure space.

IN THE DRAWINGS

20 Figure 1 is a prior art cross-sectional view of a
conventional vacuum IG unit.

Figure 2 is a prior art top plan view of the Figure 1 vacuum IG unit, taken along the section line illustrated in Figure 1.

Figure 3 is a side cross sectional view of a portion of a vacuum IG window unit according to an embodiment of this invention, where a single peripheral seal is provided.

Figure 4 is a side cross sectional view of a portion of a vacuum IG window unit according to another embodiment of this invention, where dual peripheral seals are provided.

Figure 5 is a side cross sectional view of a two-piece cylindrically or rectangularly spacer/pillar that may be used in either the Figure 3 or Figure 4 embodiment of this invention, the spacer/pillar of this embodiment functioning as both a spacer and a getter.

Figure 6 is a side cross sectional view of another two-piece spacer/pillar that may be used in either the Figure 3 or Figure 4 embodiment of this invention, the spacer/pillar of this embodiment functioning as both a spacer and a getter.

Figure 7 is a side cross sectional view of a one piece spacer/pillar that may be used in either the Figure 3 or Figure 4 embodiment of this invention, the spacer/pillar of

this embodiment functioning as both a spacer and a getter, and in some embodiments consisting essentially of getter material.

Figure 8(a) is a schematic diagram of an apparatus
5 spraying getter powder material onto the outside of a humidified spacer/pillar core according to an embodiment of this invention.

Figure 8(b) is a schematic diagram of an apparatus
melting getter powder on a spacer/pillar core using
10 microwaves, so that the getter material diffuses into or adheres to the core.

DETAILED DESCRIPTION OF
CERTAIN EMBODIMENTS OF THIS INVENTION

Referring now more particularly to the accompanying
15 drawings in which like reference numerals indicate like parts throughout the several views.

Certain embodiments of this invention relate to an improved spacer/pillar design for a vacuum insulating glass window unit, and a method of making the same. In certain
20 embodiments a spacer/pillar may function: (i) to space opposing glass sheets from one another, and (ii) as a getter

to remove outgassing from the low pressure space between the sheets which may interfere with the integrity of the vacuum. By utilizing an array of spacers/pillars that also function as getters, a separate getter is not needed although one may
5 be used in certain embodiments.

Figure 3 is a cross sectional view of thermally insulating glass panel 31 according to an embodiment of this invention. Because space 37 between the opposing substrates is at a pressure lower than atmospheric in general, this
10 type of panel is often referred to as a vacuum insulating glass (IG) unit.

Referring to Figure 3, vacuum IG unit or panel 31 includes first glass substrate 33, second glass substrate 35, low pressure or evacuated space 37 between substrates 33
15 and 35, spacers/pillars 39 for both (i) supporting and spacing the substrates 33, 35 from one another and (ii) acting as a getter, an optional pump out tube (not shown) disposed in a hole or aperture formed in substrate 33 for evacuating space 37, and peripheral or edge seal 43 that
20 hermetically seals low pressure space or cavity 37 between substrates 33, 35. Hermetic edge seal 43, as shown in Figs. 1-3, prevents air from entering space 37 and keeps the

vacuum therein. Seal 43 is located in approximately the same peripheral location in the Figure 3 embodiment as seal 4 shown in Figure 2. Glass sheets 33 and 35 may be tempered or non-tempered in different embodiments. In alternative 5 embodiments, substrates 33, 35 may be of plastic instead of glass. Substrates may be of any desirably shape (e.g. square, rectangular, round, triangular, flat, curved), although they are approximately parallel to one another in certain embodiments.

10 The Figure 4 vacuum IG embodiment is the same as the Figure 3 embodiment, except that first 43 and second 44 peripheral edge seals are provided around the entire periphery of space 37. Also in the Figure 4 embodiment, a notch or groove is formed around the periphery of sheet 33 15 with coating 36 thereover for reception of seal 43. Optional coating(s) 36 is provided over at least a portion of the groove to allow seal material 43 to better adhere to substrate 33. Coating 36 may be made of or include copper, chromium, silver, indium, ITO (indium tin oxide), or any 20 combination thereof in different embodiments. Inner seal 43 may be of or include indium in certain embodiments, while

outer seal 44 is of a suitable material (e.g. of or including butyl) to mechanically protect seal 43.

In certain embodiments of this invention, hermetic sealing material 43 may be obtained from Indium Corp. Of America, Utica, New York. For example, Indalloy Number 53 available from Indium Corp. in paste form has a composition of 67% Bi and 33% In (% by weight) for seal material 43. Indalloy Number 1 available from Indium Corp. in paste form has a composition of 50% In and 50% Sn. Indalloy Number 290 available from Indium Corp. in paste form has a composition of 97% In and 3% Ag. Indalloy Number 9 available from Indium Corp. in paste form has a composition of 70% Sn, 18% Pb and 12% In. Indalloy Number 281 available from Indium Corp. in paste form has a composition of 58% Bi and 42% Sn. Indalloy Number 206 available from Indium Corp. in paste form has a composition of 60% Pb and 40% In. Indalloy Number 227 available from Indium Corp. in paste or wire form has a composition of 77.2% Sn, 20% In and 2.8% Ag. Indalloy Number 2 available from Indium Corp. in paste or wire form has a composition of 80% In, 15% Pb and 5% Ag. Indalloy Number 4 available from Indium Corp. in paste or wire form has a composition of 100% In. Indalloy Number 205 available

from Indium Corp. in paste or wire form has a composition of 60% In and 40% Pb. Indalloy Number 3 available from Indium Corp. in paste or wire form has a composition of 90% In and 10% Ag.

5 In each of the Figure 3 and Figure 4 embodiments, glass substrate 33 is slightly larger in surface area than glass substrate 35, so as to create an L-shaped step around the edge of the unit for supporting part of the edge seal. However, in alternative embodiments, substrates 33 and 35
10 may be approximately the same size. Also, while seal 43 includes an indium inclusive slurry or wire in certain embodiments, the edge seal may instead be of fused solder glass or other suitable material(s) in other embodiments.

Referring to Figures 3-4, IG units 31 according to
15 different embodiments of this invention may be used as residential or commercial windows. The evacuation of space 37 eliminates heat transport between glass substrates 33 and 35 due to gaseous conduction and convection. In addition, radiative heat transport between glass sheets 33 and 35 can
20 be reduced to a low level by providing a low emittance (low-E) coating(s) on the internal surface of one or both of sheets 33, 35. High levels of thermal insulation can thus

be achieved. Low gaseous thermal conduction may be achieved when the pressure in space 37 is reduced to a level below about 10^{-2} Torr, more preferably below about 1.0 mTorr, or 10^{-3} Torr, and most preferably below about 10^{-6} Torr of atmospheric pressure. To maintain such low pressures, the internal surfaces of glass substrates 33 and 35 may be outgassed, and areas near the edges or peripheries of substrates 33, 35 are hermetically sealed together by seal 43, 44 that eliminates any ingress of gas or air.

10 An array of small, high strength support pillars 39 is provided between substrates 33 and 35 in order to maintain separation of the two glass sheets against atmospheric pressure. It is desirable for pillars 39 to be sufficiently small so that they are visibly unobtrusive.

15 Referring to Figures 3-4, each spacer/pillar 39 includes an inner core 40 (see also embodiments of Figures 5-6) of supporting material at least partially coated with getter coating 42. It is noted that the terms "pillar" and "spacer" are used interchangeably herein, and both mean an element disposed between and spacing the opposing substrates from one another (irrespective of the size or shape or make-up of the spacing element). Spacers 39 may be from about

20

0.05 to 1.0 mm in height in certain embodiments (most preferably from about 0.1 to 0.3 mm), and have a width or diameter of from about 0.05 to 1.0 mm.

In certain embodiments illustrated in Figures 3-6,
5 central core 40 of each spacer 39 includes or is made of high strength metal, fused solder glass, ceramic, hardened tungsten, tantalum, molybdenum, high strength steel alloy(s), aluminum oxide, or zirconium dioxide (zirconium dioxide is not a getter material). In certain embodiments,
10 core 40 is of a material having a mechanical compressive strength greater than about 750 Mpa.

In certain embodiments, getter coating 42 is non-evaporable and includes or is made of: zirconium-aluminum (Zr-Al; e.g. from about 80-86% Zr and from about 14-20% Al),
15 zirconium-iron (Zr-Fe), zirconium-vanadium-titanium-iron (Zr-V-Ti-Fe), zirconium-vanadium-iron (i.e. Zr-V-Fe), Zr inclusive alloy, titanium (Ti) inclusive alloy, niobium (Nb) inclusive alloy, tantalum (Ta) inclusive alloy, vanadium (V) inclusive alloy, Zr-Al, Zr-V, Zr-Ni, or Zr-Mn-Fe. The
20 materials listed above include substantially pure metallic elements of the metals and metallic alloys thereof. Other suitable non-evaporable metallic getter materials may also

be used as coating 42. Also, any of the getter materials described in U.S. Patent No. 5,879,583 or U.S. Patent No. 5,888,925 may be used as a getter coating or core herein, the disclosures of these '583 and '925 patents hereby being
5 incorporated herein by reference. A coating of Zr-V-Fe is preferred in certain embodiments as it is activatable at temperatures of from about 20-400° C., and can function as a getter at room temperature.

Figure 5 is a cross sectional view of cylindrically or
10 rectangularly shaped spacer/pillar 39 which may be used as any or all of the spacers 39 in the spacer array of either of the Figures 3-4 embodiments. Optionally, some of the pillars in the array may be getter inclusive while the remaining pillars need not be getter inclusive. As shown,
15 core 40 is coated on its vertically extending periphery (or lengthwise periphery) or sides with getter inclusive coating 42. Coating 42 may consist essentially of getter material, or alternatively may include getter material as well as other material. In this embodiment, the upper and lower
20 surfaces 51, 53 of the core are not coated with getter coating 42. An example of this embodiment would be where a

wafer core was coated with the getter coating and thereafter cut up into a plurality of pieces.

Figure 6 is a cross sectional view of a cylindrically or rectangularly shaped spacer/pillar 39 according to
5 another embodiment of this invention. This spacer 39 may be used as any or all of the spacers 39 in the array of either the Figure 3 or Figure 4 embodiment of this invention. In the Figure 6 embodiment, all exterior surfaces of core 40 are coated with getter inclusive coating 42. In each of the
10 Figure 5 and Figure 6 embodiments, getter coating 42 may have a thickness at a portion thereof of less than or equal to about 25 μm , more preferably less than about 5 μm , and most preferably less than or equal to about 1 μm . In alternative embodiments of this invention, a seed of pillar
15 core material may be provided of any size, and a getter coating 42 may be grown thereon to whatever thickness is necessary so that the overall resulting pillar 39 is of a satisfactory size (i.e. height, thickness, etc.)

Figure 7 is a cross sectional view of a cylindrically
20 or rectangularly shaped one-piece spacer/pillar 39 according to yet another embodiment of this invention. This spacer 39 may be used as any or all of the spacers 39 in the array of

either the Figure 3 or Figure 4 embodiment of this invention. In the Figure 7 embodiment, the entire spacer 39 is of a material that includes or is of a substantially pure elemental metallic getter material or alloy thereof. For
5 example, spacer 39 in this embodiment may be of or include any of the materials listed above that may be used to form getter coating 42 in other embodiments. Thus, spacer 39 in this embodiment may be formed of a getter material such as, but not limited to, Zr-Al, Zr-Fe, Zr-V-Ti-Fe, Zr-V-Fe, Ti
10 alloy, Nb alloy, other Zr alloys, Ta alloy, V alloy, Zr-Al, Zr-V, Zr-Ni, or Zr-Mn-Fe. It is noted that when the entire spacer/pillar 39 is formed of a getter inclusive material as in the Figure 7 embodiment, the material is to be selected of a suitable low thermal conduction material of sufficient
15 compressive strength to perform its function of supporting and spacing the opposing glass sheets from one another.

While the one-piece Figure 7 embodiment and the two-piece embodiments of Figures 5-6 illustrate and describe approximately cylindrically (the top and bottom of the
20 cylindrical pillar supporting the opposing glass sheets) or rectangularly shaped spacers 39, other shapes may instead be taken by spacers in different embodiments of this invention.

For example, spacers 39 in other one or two piece
embodiments of this invention may be approximately square
shaped, approximately round shaped, approximately oval
shaped, approximately spherical shaped, approximately
5 hemispherical shaped, shaped as a multi-faceted spherical
member, approximately trapezoidal shaped, or shaped in any
way illustrated in U.S. Patent No. 5,891,536 the disclosure
of which is incorporated herein by reference.

Getter materials described herein (e.g. see coating 42
10 and the core of the Figure 7 embodiment) act by
chemisorption of gases such as carbon monoxide, carbon
dioxide, water, molecular oxygen, and/or molecular hydrogen,
or other gases, for example. Most of these gases remain
retained near, at or on the surface of the getter material
15 at certain temperatures (i.e. adsorbed). However, some
materials may dissociate and diffuse into the getter
material as a function of temperature. These non-evaporable
getters are used to create and maintain high vacuum
conditions within space 37. In other words, these getters
20 remove a substantial amount of any outgassing that might
compromise the integrity of the vacuum in space 37, by
adsorbing gas(es) present in space 37 (e.g. outgassing may

occur during sealing of the pump out tube). Non-evaporable
getters used herein provide gettering capability without
having to evaporate substantial material. Substantial
getter surface area of getter material in space 37 is
5 provided by having getter material on surfaces of spacers
39. In certain embodiments (e.g. two-piece Figures 5-6
embodiments), substantially pure elemental metal getter
starting materials are used and the alloying of the
materials together in a single melting during spacer
10 formation may decrease manufacturing costs and provide high
quality getter alloy formation.

For purposes of example only, without limitation,
certain steps of an exemplary procedure for making a vacuum
IG unit 31 with two-piece getter spacers 39 according to an
15 embodiment of this invention are described below. To begin,
substrates 33 and 35 are provided (e.g. float glass). A
diamond bit scribe is used and manipulated around an outer
peripheral area of substrate 33 to form continuous
peripheral groove shown in Figure 4. After the groove is
20 formed, coating 36 is deposited and formed on substrate 33
over the groove so as to extend outwardly from the edges
thereof.

Referring to Figures 8(a) and 8(b), the pillar may be formed as follows in certain embodiments. Core 40 is provided and humidified. Apparatus 62 sprays elemental metal getter powder (of any getter material listed above) 68 of sub-micron size toward core 40, with the powder sticking to the humidified core. For example, when Zr-V-Fe getter material is used, a homogeneous mixture of each of these elemental metals is sprayed onto the humidified core. After the powder 68 contacts core 40, apparatus 64 emits microwaves 66 toward the coated core as shown in Figure 8(b) in an inert atmosphere or in a vacuum chamber. Powder metal 68 absorbs the microwave energy thereby melting and diffusing into the surface of core 40 to provide a non-evaporable getter coating 42 on the core to form spacer/pillar 39.

Getter spacers/pillars 39 are then deposited in an array on substrate 33. A slurry of indium inclusive material is placed so as to be at least partially within the groove in the area where the hermetic seal is to be formed. Upper substrate 35 is then laid over and placed on bottom substrate 33 with the seal material either solely or partly maintaining spacing between the substrates. The upper sheet

is then pressed down toward the lower sheet 33 (or vice versa, or both pressed together) so that the spacers support the sheets and define space 37.

If a pump out tube is to be used to evacuate space 37, then the unit (e.g. including the two substrates, getter pillars 39, and seal material therebetween) is heated to a temperature of about 100-500 degrees C (e.g. about 450 degrees C for up to about 8-9 hours, and then reduced to about 280-300 degrees C for up to about one hour during pump out, for solder glass lead composite peripheral seals) to degas the glass substrates, activate the getter, and deform the seal material to form hermetic seal 43.

However, in alternative embodiments, the pump out tube may be eliminated. In such embodiments, each substrate 33, 35 is placed in a degassing chamber prior to the seal material and pillars being laid down and prior to being placed on one another. This chamber is heated to from about 100-300 degrees C, preferably from about 125 to 300 C, for about 30-90 minutes to get water vapor and other gas(es) out of the glass substrates (e.g. for any of the above identified indium inclusive peripheral seals). Then, the glass substrates are taken to a vacuum chamber having a

pressure desired to be the final pressure in space 37. In this vacuum chamber, sealing material is laid down or deposited as are getter pillars 39 on substrate 33, and the upper substrate 35 is then laid on the lower one 33 with the pillars and slurry material therebetween. The temperature in the vacuum chamber is set to less than about 300° C. for the slurry deformation and getter activation, preferably less than or equal to about 200° C. and most preferably less than or equal to about 150° C. When top substrate 35 is pressed downward toward the lower substrate (or vice versa) the slurry or wire deforms (e.g. flattens or partially flattens) between the substrates at this temperature into hermetic seal 43.

Afterwards, the vacuum IG unit with hermetic seal 43 and activated getters are taken out of the evacuated oven area and allowed to cool. Optionally, before being taken to an atmospheric area, the center of the glazing may be blasted with room temperature air from both sides to cool the center faster than edge areas.

Once given the above disclosure, many other features, modifications, and improvements will become apparent to the skilled artisan. Such other features, modifications, and

improvements are, therefore, considered to be a part of this invention, the scope of which is to be determined by the following claims.

WE CLAIM:

1 1. A thermally insulating glass panel comprising:
2 first and second spaced apart glass substrates
3 defining a low pressure space therebetween;
4 a seal interconnecting said first and second
5 spaced apart glass substrates so as to hermetically seal
6 said low pressure space between said substrates; and
7 an array of getter inclusive spacers disposed in
8 said low pressure space for maintaining separation of said
9 first and second glass substrates.

1 2. The thermally insulating glass panel of claim 1,
2 wherein at least one of said spacers includes a core and a
3 getter coating provided on at least one portion of said
4 core.

1 3. The thermally insulating glass panel of claim 2,
2 wherein said getter coating is metallic and is provided on
3 all substantially all surfaces of said core.

1 4. The thermally insulating glass panel of claim 2,
2 wherein said getter coating is metallic and includes one of:

3 Zr-Al alloy; Zr-Fe alloy; Zr-V-Ti-Fe alloy; Zr-V-Fe alloy;
4 Zr-V alloy; Zr-Ni alloy; Zr-Mn-Fe alloy; Ti inclusive alloy;
5 Zr inclusive alloy; V inclusive alloy; Nb inclusive alloy;
6 and Ta inclusive alloy.

1 5. The thermally insulating glass panel of claim 2,
2 wherein said getter coating has a thickness in at least one
3 substantial area thereof of less than or equal to about 25
4 μm .

1 6. The thermally insulating glass panel of claim 1,
2 wherein said spacer is one of: approximately cylindrical in
3 shape; approximately square in shape; approximately oval in
4 shape; and approximately spherical in shape.

1 7. The thermally insulating glass panel of claim 1,
2 wherein said spacer is a metallic one-piece spacer.

1 8. The thermally insulating glass panel of claim 7,
2 wherein said spacer includes one of: Zr-Al alloy; Zr-Fe
3 alloy; Zr-V-Ti-Fe alloy; Zr-V-Fe alloy; Zr-V alloy; Zr-Ni
4 alloy; Zr-Mn-Fe alloy; Ti inclusive alloy; Zr inclusive

5 alloy; V inclusive alloy; Nb inclusive alloy; and Ta
6 inclusive alloy.

1 9. The thermally insulating glass panel of claim 1,
2 wherein said seal includes indium.

1 10. An insulating glass (IG) unit comprising:

2 first and second glass substrates spaced from one
3 another to define a low pressure space therebetween, said
4 low pressure space having a pressure less than atmospheric
5 pressure;

6 a plurality of spacers or pillars disposed in said
7 low pressure space between said first and second substrates
8 to space said glass substrates from one another; and

9 wherein at least one of said spacers includes a
10 getter material.

1 11. The insulating glass unit of claim 10, wherein a
2 plurality of said spacers include getter material for
3 absorbing substantial amounts of gas located in said low
4 pressure space, and said getter material includes one of:
5 Zr-Al alloy; Zr-Fe alloy; Zr-V-Ti-Fe alloy; Zr-V-Fe alloy;

6 Zr-V alloy; Zr-Ni alloy; Zr-Mn-Fe alloy; Ti inclusive alloy;
7 Zr inclusive alloy; V inclusive alloy; Nb inclusive alloy;
8 and Ta inclusive alloy.

1 12. The insulating glass unit of claim 10, wherein at
2 least one of said spacers includes a core and a getter
3 coating provided on at least one portion of said core.

1 13. The insulating glass unit of claim 12, wherein
2 said getter coating is metallic and is provided on all
3 surfaces of said core.

1 14. The insulating glass unit of claim 10, wherein
2 said at least one spacer is a metallic one-piece spacer
3 consisting essentially of a getter inclusive material.

1 15. A method of making a thermally insulating product,
2 the method comprising the steps of:
3 providing first and second substrates;
4 providing at least one spacer core;
5 providing a getter powder on the spacer core;

6 the getter powder absorbing microwave energy and
7 diffusing into a surface of the core to form a getter spacer
8 including a getter coating; and
9 positioning the getter spacer between the first
10 and second substrates.

1 16. The method of claim 15, further comprising the
2 steps of:
3 forming a low pressure space having a pressure
4 less than atmospheric pressure between the first and second
5 substrates;
6 positioning the getter spacer in the low pressure
7 space; and
8 the getter adsorbing gas located within the low
9 pressure space to help maintain integrity of vacuum in the
10 low pressure space.

1 17. The method of claim 16, wherein said step of
2 providing a getter powder on the spacer core includes
3 providing a metallic powder on the core where the powder

4 includes one of: Ti inclusive alloy; Zr inclusive alloy; V
5 inclusive alloy; Nb inclusive alloy; and Ta inclusive alloy.

1 18. The method of claim 16, further comprising the
2 step of humidifying the core prior to providing the getter
3 powder thereon.

1 19. A method of maintaining vacuum in a low pressure
2 space between first and second substrates, said method
3 comprising the steps of:

4 providing a plurality of getter spacers in the low
5 pressure space between the first and second substrates to
6 support the substrates and space the substrates from one
7 another; and

8 the spacers adsorbing gas present in the low
pressure space to maintain vacuum

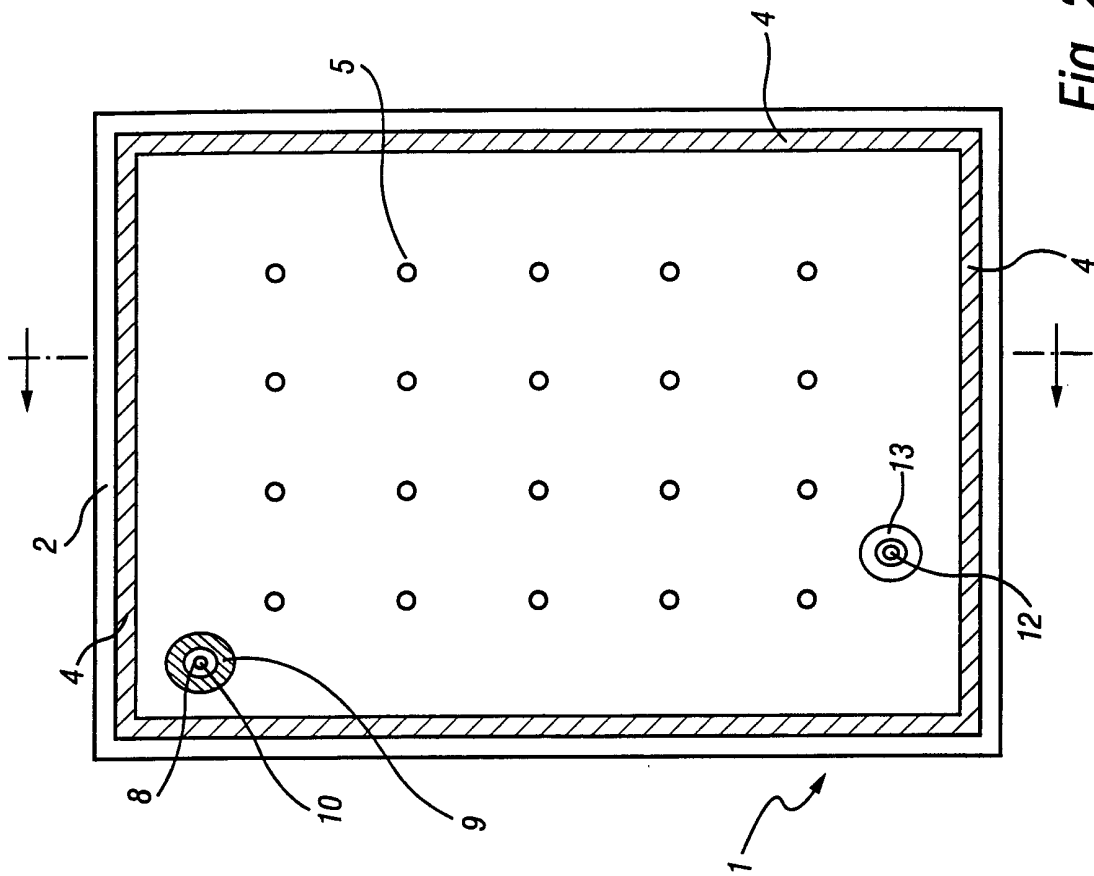

Fig. 2
(Prior Art)

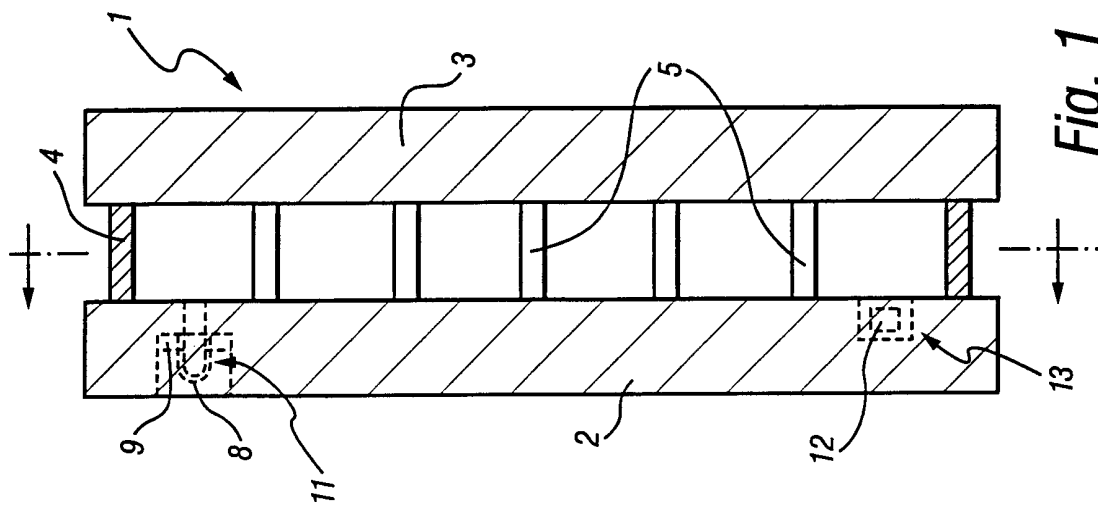

Fig. 1
(Prior Art)

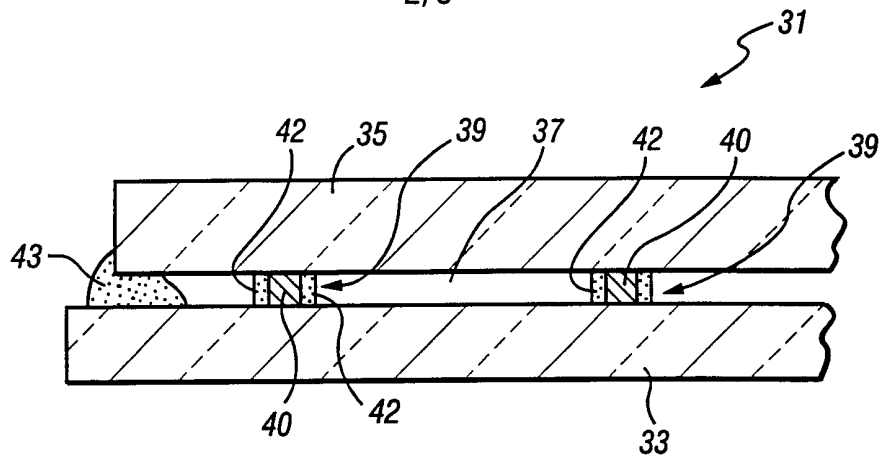

Fig. 3

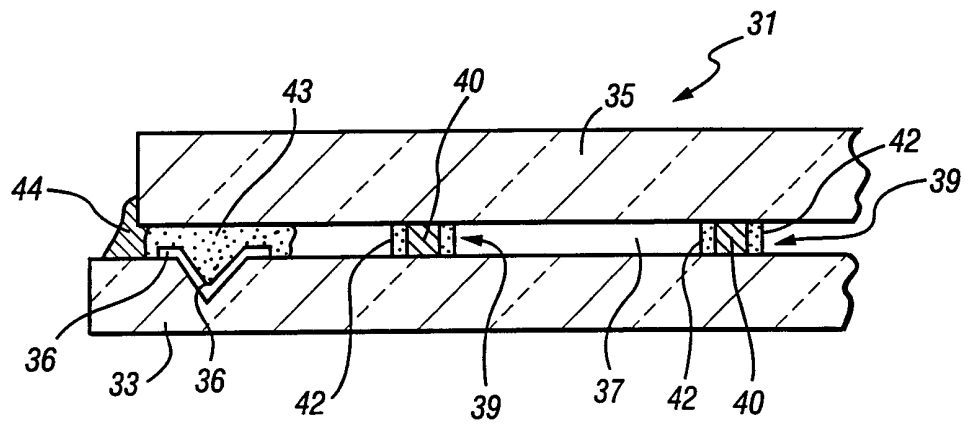

Fig. 4

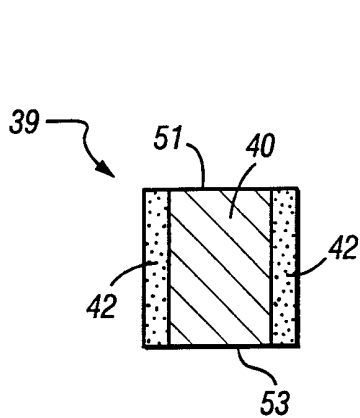

Fig. 5

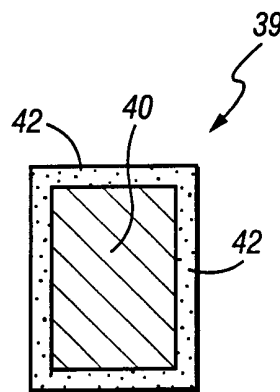

Fig. 6

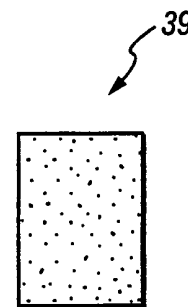

Fig. 7

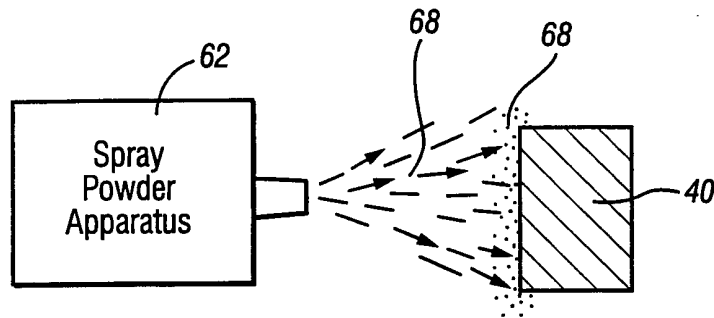

Fig. 8(a)

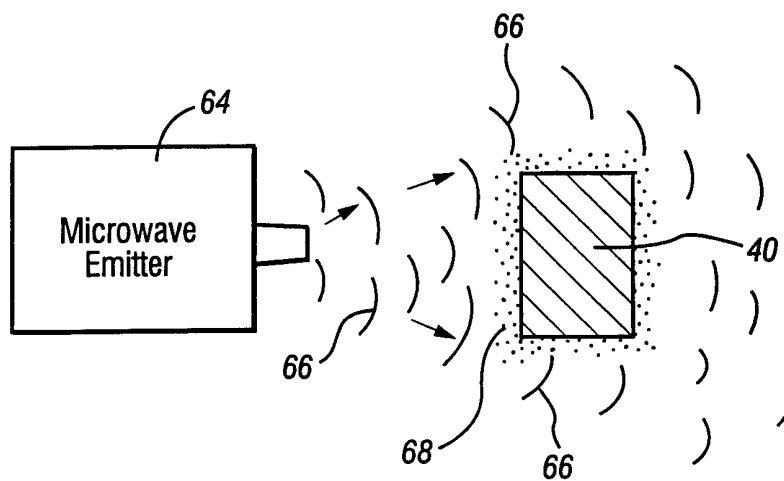

Fig. 8(b)

INTERNATIONAL SEARCH REPORT

Intern: 31 Application No

PCT/US 00/21558

A. CLASSIFICATION OF SUBJECT MATTER
IPC 7 E06B3/663

According to International Patent Classification (IPC) or to both national classification and IPC

B. FIELDS SEARCHED

Minimum documentation searched (classification system followed by classification symbols)

IPC 7 E06B A47J C03C

Documentation searched other than minimum documentation to the extent that such documents are included in the fields searched

Electronic data base consulted during the international search (name of data base and, where practical, search terms used)

EPO-Internal, PAJ, WPI Data

C. DOCUMENTS CONSIDERED TO BE RELEVANT

Category °	Citation of document, with indication, where appropriate, of the relevant passages	Relevant to claim No.
A	EP 0 421 239 A (PPG INDUSTRIES INC) 10 April 1991 (1991-04-10) column 11, line 24 - line 44 figures ---	1, 10, 15, 19
A	US 4 683 154 A (TRACY C EDWIN ET AL) 28 July 1987 (1987-07-28) cited in the application abstract column 8, line 14 - line 24 figure 1 -----	1, 10, 15, 19

Further documents are listed in the continuation of box C.

Patent family members are listed in annex.

° Special categories of cited documents :

- "A" document defining the general state of the art which is not considered to be of particular relevance
- "E" earlier document but published on or after the international filing date
- "L" document which may throw doubts on priority claim(s) or which is cited to establish the publication date of another citation or other special reason (as specified)
- "O" document referring to an oral disclosure, use, exhibition or other means
- "P" document published prior to the international filing date but later than the priority date claimed

- "T" later document published after the international filing date or priority date and not in conflict with the application but cited to understand the principle or theory underlying the invention
- "X" document of particular relevance; the claimed invention cannot be considered novel or cannot be considered to involve an inventive step when the document is taken alone
- "Y" document of particular relevance; the claimed invention cannot be considered to involve an inventive step when the document is combined with one or more other such documents, such combination being obvious to a person skilled in the art.
- "&" document member of the same patent family

Date of the actual completion of the international search

23 October 2000

Date of mailing of the international search report

27/10/2000

Name and mailing address of the ISA

European Patent Office, P.B. 5818 Patentlaan 2
NL - 2280 HV Rijswijk
Tel. (+31-70) 340-2040, Tx. 31 651 epo.nl,
Fax: (+31-70) 340-3016

Authorized officer

Verdonck, B

INTERNATIONAL SEARCH REPORT

Information on patent family members

International Application No

PCT/US 00/21558

Patent document cited in search report	Publication date	Patent family member(s)	Publication date
EP 0421239 A	10-04-1991	US 5124185 A CA 2025837 A,C DE 69024898 D DE 69024898 T DK 421239 T NO 180211 B	23-06-1992 04-04-1991 29-02-1996 05-09-1996 10-06-1996 25-11-1996
US 4683154 A	28-07-1987	NONE	