

(No Model.)

H. HEITMANN.

MOTOR.

No. 395,232.

Patented Dec. 25, 1888.

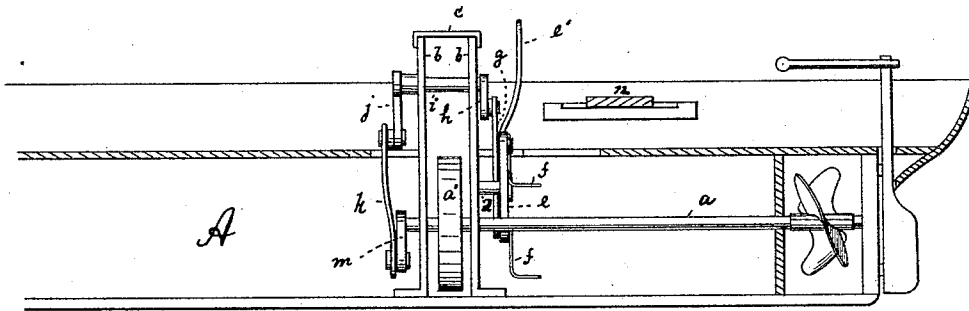

FIG. 1

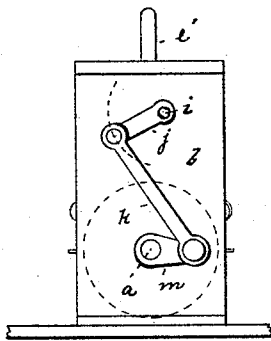

FIG. 2

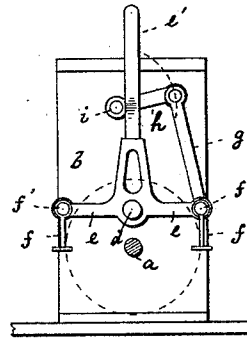

FIG. 3

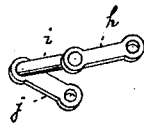

FIG. 4

WITNESSES

Wm. A. Lowe
Walter C. Norris

INVENTOR

H. Heitmann
by his attorneys
Roderick Briesew

UNITED STATES PATENT OFFICE.

HENRY HEITMANN, OF NEW ROCHELLE, NEW YORK.

MOTOR.

SPECIFICATION forming part of Letters Patent No. 395,232, dated December 25, 1888.

Application filed September 15, 1888. Serial No. 285,504. (No model.)

To all whom it may concern:

Be it known that I, HENRY HEITMANN, of New Rochelle, Westchester county, State of New York, have invented an Improved Motor, of which the following is a specification.

This invention relates to an improved motor especially applicable for revolving the propeller of a boat; but the motor may also be applied for other purposes—such as propelling a wagon—or it may be used as a stationary machine.

The invention consists in the various features of improvement more fully pointed out in the claims.

In the accompanying drawings, Figure 1 is a longitudinal section of a boat provided with my improved motor, showing the latter in side view. Fig. 2 is a front view, and Fig. 3 a rear view, of the motor. Fig. 4 is a detail perspective view of the rock-shaft.

The letter A represents a boat having the propeller-shaft *a*. This shaft passes through the two uprights *b b*, which are connected on top by a cross-piece, *c*. Between the uprights *b b* the shaft *a* carries a fly-wheel, *a'*. In order to revolve the shaft *a*, I pivot to a pin, *d*, projecting from one of the uprights *b*, a foot-lever, *e*, to each end of which a treadle, *f*, is pivoted. One of the pivots *f'* of lever *e* connects one end of a link, *g*, to the foot-lever *e*, the other end of which link is pivoted to a crank, *h*, of a rock-shaft, *i*, resting in the uprights *b b*. The other end of shaft *i* has the crank *j*, connected by connecting-rod *k* with crank *m* on shaft *a*. The crank *h*, as well as the crank *j* of the shaft *i*, is longer than the crank *m* of shaft *a*, and both cranks *h j* project from their shaft *i* at a different angle.

n is the seat of the operator who bears with

his feet upon treadles *f*. The alternate raising and depression of the treadles will oscillate the lever *e*, and the link *g* will cause the crank *h* to move in the arc of the circle indicated by dotted lines in Fig. 2. Thus the rock-shaft *i* will impart a similar motion to crank *j*, and the latter will through rod *k* revolve the crank *m*, and consequently the shaft *a*. The fly-wheel *a'* carries the crank *m* over its dead-center. The crank *j*, being longer than the crank *m* and moving only in the arc of a circle, prevents said crank from ever being at its dead-center, while the fly-wheel *a'* carries the crank *m* over its dead-center. The foot-lever *e* may also be provided with a hand-bar, *e'*.

What I claim is—

1. The combination of pivoted bar *e* with link *g*, rock-shaft *i*, having cranks *h j*, and with connecting-rod *k*, crank *m*, shaft *a*, and fly-wheel *a'*, substantially as specified.

2. The combination of pivoted bar *e*, having pivoted treadles *f*, with the link *g*, connected to pivot *f'*, and with the rock-shaft *i*, having cranks *h j*, and with connecting-rod *k*, and crank *m*, shaft *a*, and fly-wheel *a'*, substantially as specified.

3. The combination of pivoted bar *e* with the link *g*, pivoted thereto, and with a rock-shaft, *i*, having a pair of cranks, *h j*, and with the revolving shaft *a*, having crank *m*, that is connected to crank *j* by connecting-rod *k*, and with fly-wheel *a'*, all being so constructed that the cranks *j h* are longer than crank *m*, substantially as specified.

HENRY HEITMANN.

Witnesses:

F. V. BRIESEN,
A. JONGHMANS.