

June 19, 1928.

1,673,802

E. C. CRAGO

TUBING CATCHER

Filed Oct. 21, 1927

2 Sheets-Sheet 1

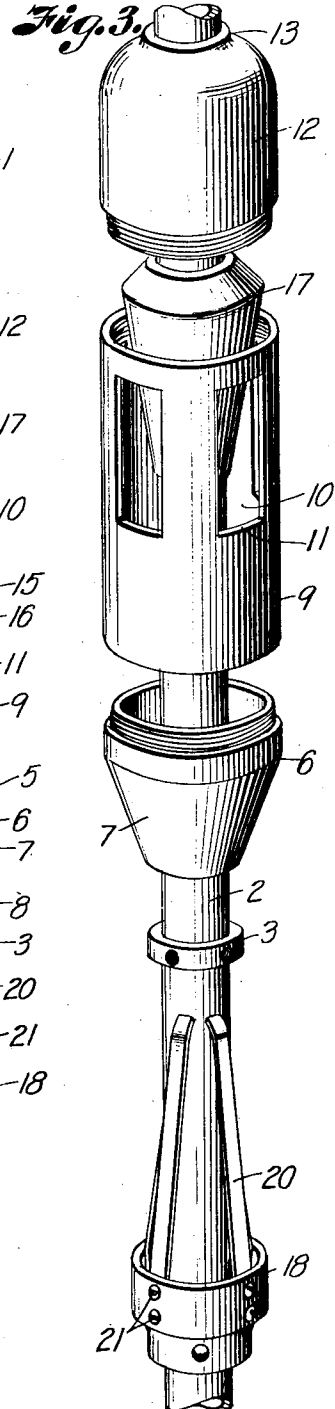
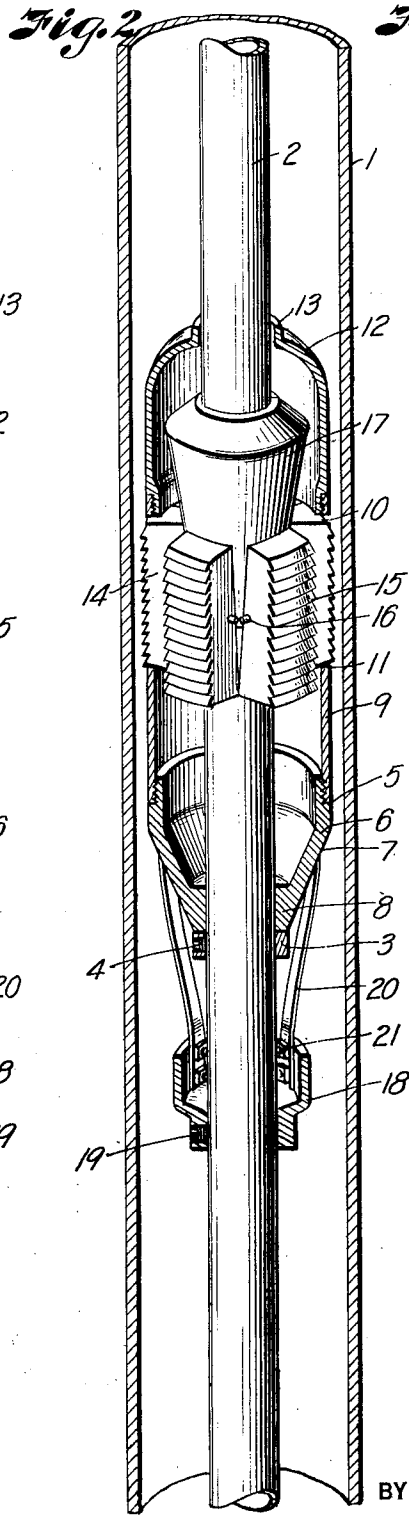
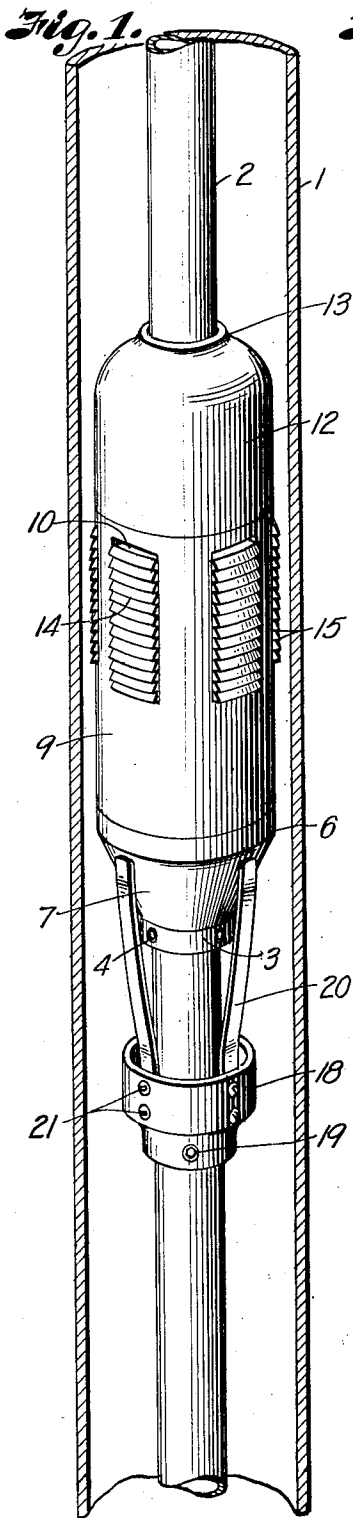

INVENTOR
Edward C. Crago
BY *Arthur C. Brown*
ATTORNEY

June 19, 1928.

1,673,802

E. C. CRAGO

TUBING CATCHER

Filed Oct. 21, 1927

2 Sheets-Sheet 2

Fig. 4.

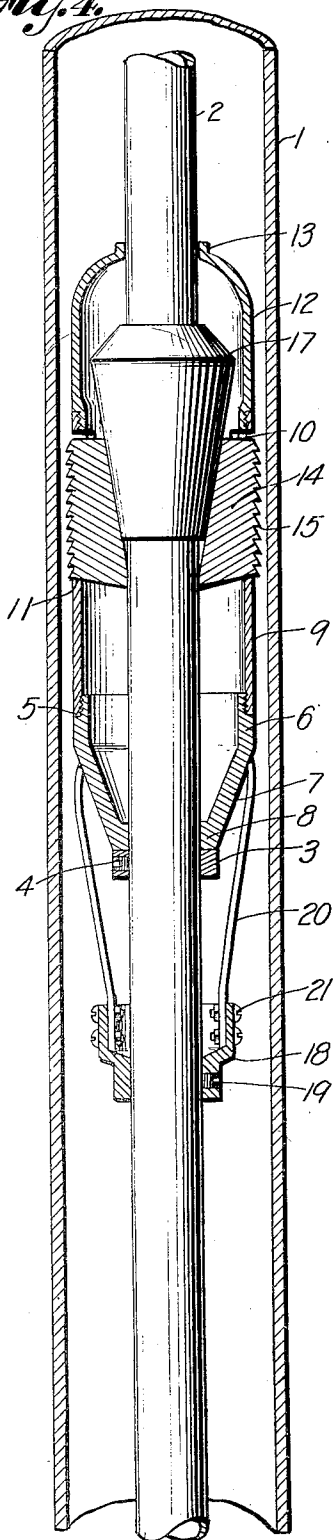

Fig. 5.

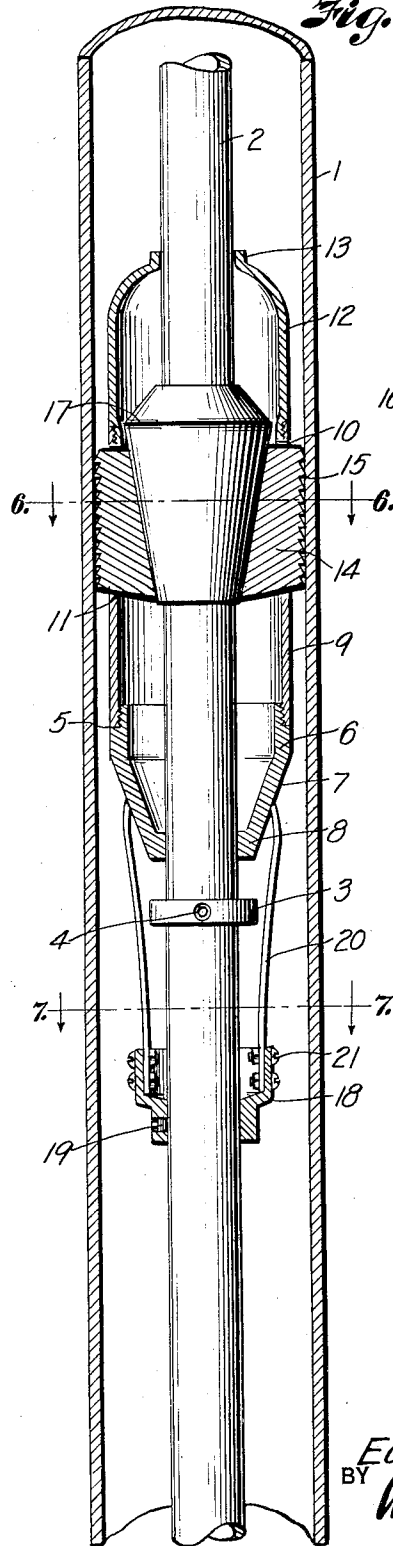

Fig. 6.

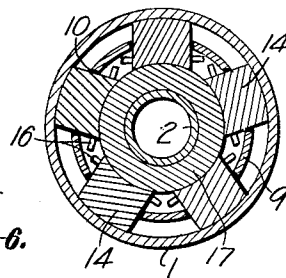
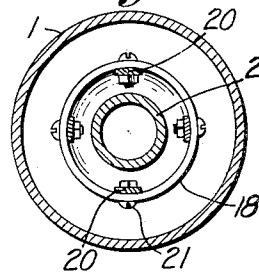

Fig. 7.



INVENTOR
Edward C. Crago
BY *Arthur C. Brown*
ATTORNEY

Patented June 19, 1928.

1,673,802

UNITED STATES PATENT OFFICE.

EDWARD C. CRAGO, OF KANSAS CITY, MISSOURI, ASSIGNOR TO THE ELLIS MANUFACTURING COMPANY, OF KANSAS CITY, KANSAS, A CORPORATION OF KANSAS.

TUBING CATCHER.

Application filed October 21, 1927. Serial No. 227,739.

My invention relates to tubing catchers and has for its principal object to provide a device of that character for use in connection with deep oil wells for automatically attaching the tubing to the well casing to prevent loss of the tubing in case of breakage of the tubing or escape of the tubing from its support at the top of the well.

In accomplishing this object I have provided improved details of structure, the preferred forms of which are illustrated in the accompanying drawings, wherein:

Fig. 1 is a perspective view of a tubing catcher embodying my improvements, illustrating its application to well tubing and its relation to well casing, the well casing being shown in central, longitudinal section.

Fig. 2 is a similar view, the shell of the tubing catcher being in central, longitudinal section to better illustrate the interior elements.

Fig. 3 is a detail perspective view of the several elements of the device, in spaced relation.

Fig. 4 is a central longitudinal section of the device and well casing within which it is employed, illustrating the parts in non-functional position.

Fig. 5 is a similar view illustrating the parts in functional position.

Fig. 6 is a cross section on the line 6—6, Fig. 5.

Fig. 7 is a cross section on the line 7—7, Fig. 5.

Referring more in detail to the drawings: 1 designates well casing and 2 tubing within the casing. Attached to the tubing 2 at a point in its length at which the catcher is to be located is a collar 3 which may be rigidly but adjustably fixed to the tubing by a set screw 4.

5 designates a carriage including a base 6 having a downwardly and inwardly tapering outer face 7 and terminating in a head 8 slidable on the tubing 2 and adapted for support on the collar 3. Threaded onto the base 6 is a shell 9 of substantially greater diameter than the tubing and provided with a series of radial openings 10, preferably rectangular and having downwardly and inwardly beveled lower edges 11. Threaded onto the top of the shell 9 is a hood 12 having a restricted upper end terminating in a neck 13 slidable on the tubing 2. Seated in the radial openings 10 of the shell 9

are slips 14, having transversely serrated outer faces forming downwardly projected teeth 15 for gripping engagement with the inner face of the well casing when the slips are extended; the inner faces of the slips being downwardly and inwardly tapered to provide cam faces whereby the slips may be expanded by a cooperating element on the tubing and the bottom of the slips being upwardly and outwardly tapered cooperating with the beveled lower edges of the openings 10 for return of the slips into the carriage when the slips are unrestrained. Attached to the side walls of the slips near their inner edges and preferably above their longitudinal centers are pins 16 for engagement with the shell 9 to limit outward projection of the slips and prevent their escape from the carriage.

Fixed to the tubing 2 within the carriage 6 and above the slips 14 is an inverted conical block 17 adapted for engagement with the slips when the tubing moves downwardly through the carriage to expand the slips and effect their gripping engagement with the well tubing.

Differential in inertia of the tubing and carriage will effect separation of these elements in case of accelerated movement of the tubing downwardly in the well following a break in the tubing or its escape from its support at the top of the well, but to insure operation of the catcher upon such differential movement of the tubing and carriage, I provide a secondary support for the carriage that becomes effective for restraining the carriage against downward thrust from the expander on the tubing to the slips on the carriage, and preferably consisting of a sleeve 18 attached to the tubing below the collar 3 by set screws or the like 19 and flat spring arms 20 attached to the sleeve 18 by bolts or the like 21 and extending upwardly along the tubing in spaced relation and in wiping contact with the tapered face 7 of the base 6, the spring arms being sufficiently flexible to spread and receive the tapered base and sufficiently strong to support the carriage at various points of spacing from its primary support on collar 3, as will presently be described.

In equipping a well with my improved form of tubing catcher, one of the devices is applied to the tubing by stringing the sleeve 18 and collar 3 on the tubing and attaching

the same thereto in spaced relation by their set screws. The carriage with the slips assembled therein, but without the hood 12, is then strung on the tubing until the base 6 rests on the collar 3 and the tapered base flexibly gripped by the arms 20. The expander 17 is then strung on the tubing and attached thereto in proper relation to the slips and the hood 12 finally applied to the tubing and secured to the carriage shell 9, thereby forming a housing for the slips and expanders. The tubing so equipped may be let into the well and in case of breakage of the tubing or its escape from its support at the top of the well, differential in inertia between the tubing and carriage will result in a movement of the tubing downwardly through the carriage, causing the expander 17 to engage the slips and force the slips outwardly into gripping contact with the well casing.

While differential in inertia of the tubing and carriage is sufficient to bring the expander into contact with the slips, it is necessary to restrain the carriage against thrust of the expander and insure spread of the slips to their gripping contact. Such restraint is provided by the secondary support including the spring fingers 20, which follow along the tapered face of the base 6, as the collar 18 is carried downwardly with the more rapidly moving tubing, so that the carriage is retarded by the spring arms during such spreading movement of the parts.

Should the tubing catcher be operated upon breakage of the tubing or escape of the tubing from its upper support, the lower portion of the tubing will be suspended in the well and will not fall to the bottom and damage the well, and the part of the tubing above the catcher may be engaged by suitable fishing tools and removed from the well, the slips contracting when disengaged from the expander to release their grip on the casing.

While I have referred to and illustrated but one of the devices in combination with the tubing, it is apparent that a number of them may be employed at different points throughout the length of the tubing.

What I claim and desire to secure by Letters Patent is:

1. In combination with well tubing, a carriage mounted for independent movement on the tubing, slips on the carriage, means on the tubing for expanding the slips, means on the tubing for supporting the carriage in non-functional position, and other means on the tubing for supporting the carriage during differential travel of the tubing and carriage.

2. In combination with well tubing, a carriage mounted for independent movement on the tubing, slips on the carriage, means on the tubing for expanding the slips, means on

the tubing for positively supporting the carriage in non-functional position, and yielding means on the tubing for supporting the carriage during differential travel of the tubing and carriage.

3. In combination with well tubing, a carriage movable longitudinally on the tubing, slips mounted for radial expansion on the carriage, means on the tubing for expanding the slips, means normally supporting the carriage in non-functional position, and means frictionally engaging the carriage to progressively support the carriage during differential travel of the tubing and carriage.

4. In combination with well tubing, a carriage slidable on the tubing, an expansible set of slips mounted on the carriage, an expander on the tubing, means on the tubing normally supporting the carriage with the slips spaced from the expander, and flexible means carried by the tubing and progressively restraining the carriage upon movement of the tubing through the carriage to promote actuation of the slips by the expander.

5. In combination with well tubing, a carriage slidable on the tubing, slips on the carriage, an expander on the tubing, means on the tubing normally supporting the carriage in non-functional position relative to the expander, and flexible arms mounted on the tubing and engaging the carriage to restrain the carriage during differential movement of the tubing and carriage in a direction to contact the expander with said slips.

6. In combination with well tubing, a carriage slidable on the tubing having a conical lower end, slips on the carriage, an expander on the tubing, means on the tubing normally positively supporting the carriage in non-functional position relative to the expander, and a cage mounted on the tubing including flexible arms having wiping engagement with the conical end of the carriage for progressively restraining the carriage upon movement of the tubing through the carriage.

7. In combination with well tubing, a carriage loose on the tubing and having a tapered lower end, slips on the carriage having tapered inner faces, a tapered expander on the tubing, a collar adjustable on the tubing for normally supporting the carriage in non-functional position relative to the expander, a sleeve adjustable on the tubing, below said collar, and flexible arms on the sleeve, engaging the tapered end of the carriage to progressively restrain the carriage during movement of the tubing through the carriage.

8. In combination with well tubing, a carriage in sliding relation to the tubing including a shell having radial openings, slips assembled in the carriage for radial projection through said openings, an expander on

the tubing, means on the tubing normally supporting the carriage in non-functional position, and flexible means carried by the tubing for restraining the carriage upon movement of the tubing through the carriage.

9. In combination with well tubing, a carriage in sliding relation to the tubing including a shell having radial openings, slips assembled in the carriage for radial projection through said openings, means on the slips engageable with the carriage for retaining the slips, an expander on the tubing, means on the tubing normally supporting the carriage in non-functional position, and flexible means carried by the tubing for re-

straining the carriage upon movement of the tubing through the carriage.

10. In combination with well tubing, a carriage slidable on said tubing including a shell having radial openings, slips mounted in said openings, the lower edges of the openings and slips being beveled to induce contraction of the slips, an expander on the tubing, means on the tubing normally supporting the carriage in non-functional position, and flexible means on the tubing progressively restraining the carriage upon movement of the tubing through the carriage.

In testimony whereof I affix my signature.

EDWARD C. CRAGO.