

<p>(21) Application No: 0301803.3</p> <p>(22) Date of Filing: 27.01.2003</p> <p>(71) Applicant(s): Hewlett-Packard Company (Incorporated in USA - Delaware) 3000 Hanover Street, Palo Alto, California 94304, United States of America</p> <p>(72) Inventor(s): Andrew Hana John Patrick Hardwick Robert Morling</p> <p>(74) Agent and/or Address for Service: Hewlett-Packard Limited Intellectual Property Section, Building 3, Filton Road, Stoke Gifford, BRISTOL, BS34 8QZ, United Kingdom</p>	<p>(51) INT CL⁷: G06F 11/10 // G11B 20/18</p> <p>(52) UK CL (Edition W): G4A AEE G5R RB22 RB33</p> <p>(56) Documents Cited: EP 0957484 A1 EP 0551973 A2 US 6311305 B1 US 4477903 A US 4413340 A</p> <p>(58) Field of Search: UK CL (Edition V) G4A, G5R INT CL⁷ G06F, G11B Other: ONLINE: WPI, EPODOC, PAJ, TXTE, INSPEC</p>
---	--

(54) Abstract Title: **Logical data grouping in digital storage system**

(57) A method of formatting a block of user data comprising: arranging the block of user data into rows and columns of bytes, i.e. array 500, and applying an error correction code to individual rows of bytes, such that the rows each comprise four code words. The code words may be C2 code words and may be interleaved along the length of the row. Each column may comprise two C1 code words which may also be interleaved. Additionally, a metal particle type tape storage device, having a width of 3.81mm plus or minus 0.01mm and a length of 170m plus or minus 5m, is claimed.

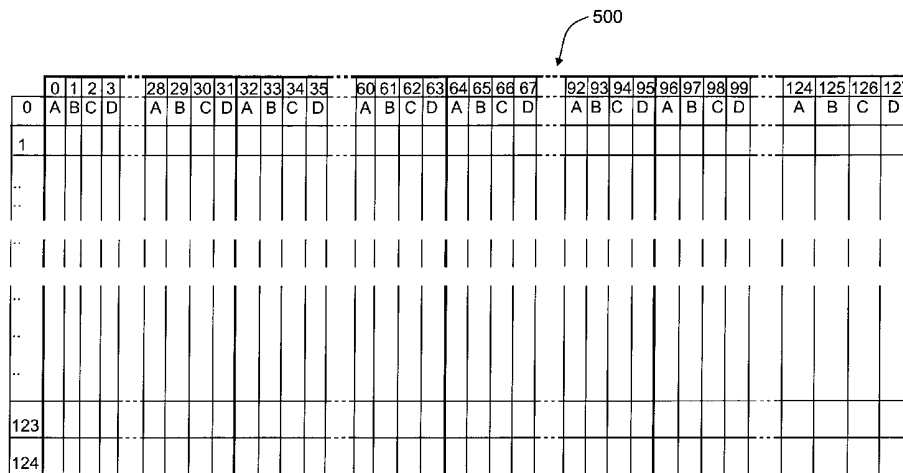

Fig. 5

At least one drawing originally filed was informal and the print reproduced here is taken from a later filed formal copy.

This print takes account of replacement documents submitted after the date of filing to enable the application to comply with the formal requirements of the Patents Rules 1995

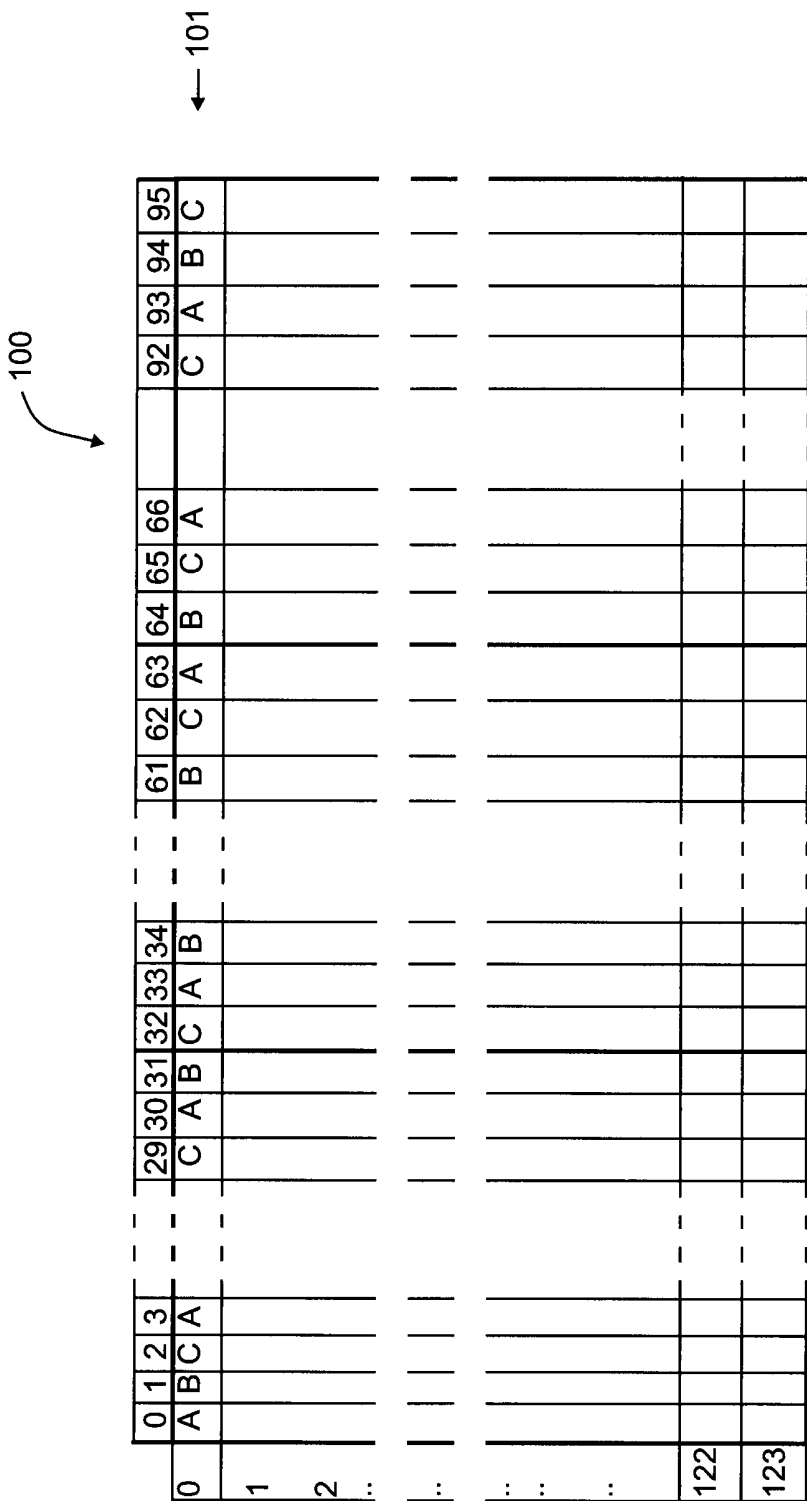

Fig. 1
(Prior Art)

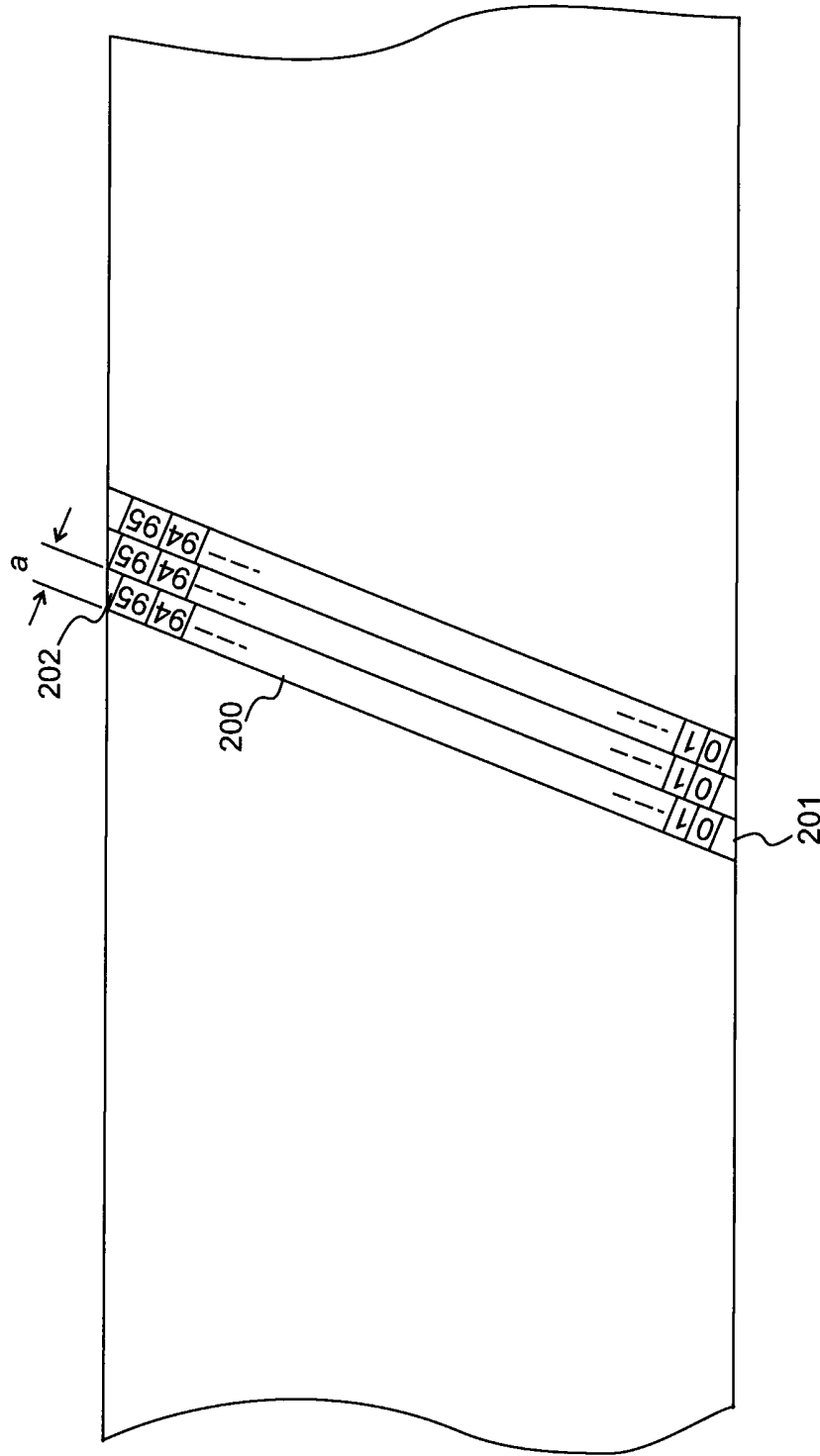

Fig.2
(Prior Art)

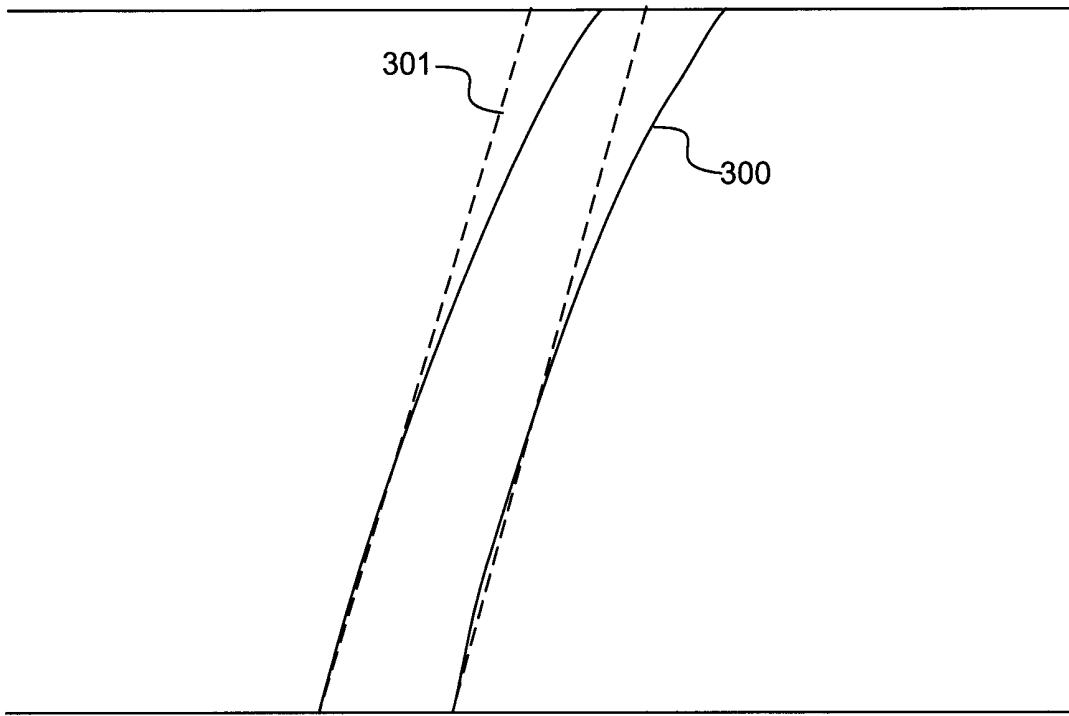
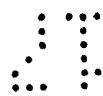

Fig.3



4/8

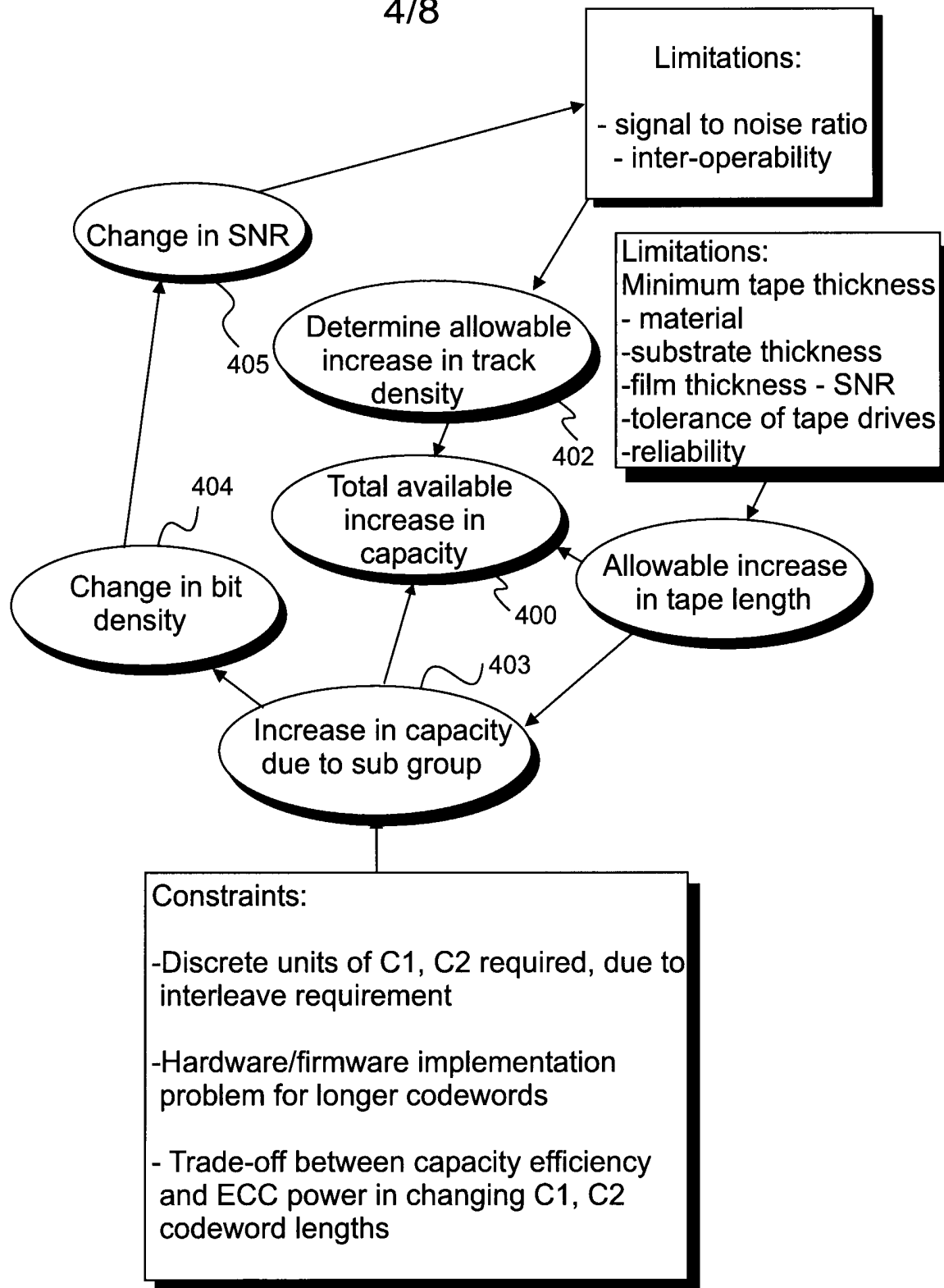

Fig. 4



500

	0	1	2	3	...	28	29	30	31	32	33	34	35	...	60	61	62	63	64	65	66	67	...	92	93	94	95	96	97	98	99	...	124	125	126	127
0	A	B	C	D	...	A	B	C	D	A	B	C	D	...	A	B	C	D	A	B	C	D	...	A	B	C	D	A	B	C	D	...	A	B	C	D
1									
...									
...									
...									
123									
124									

Fig. 5

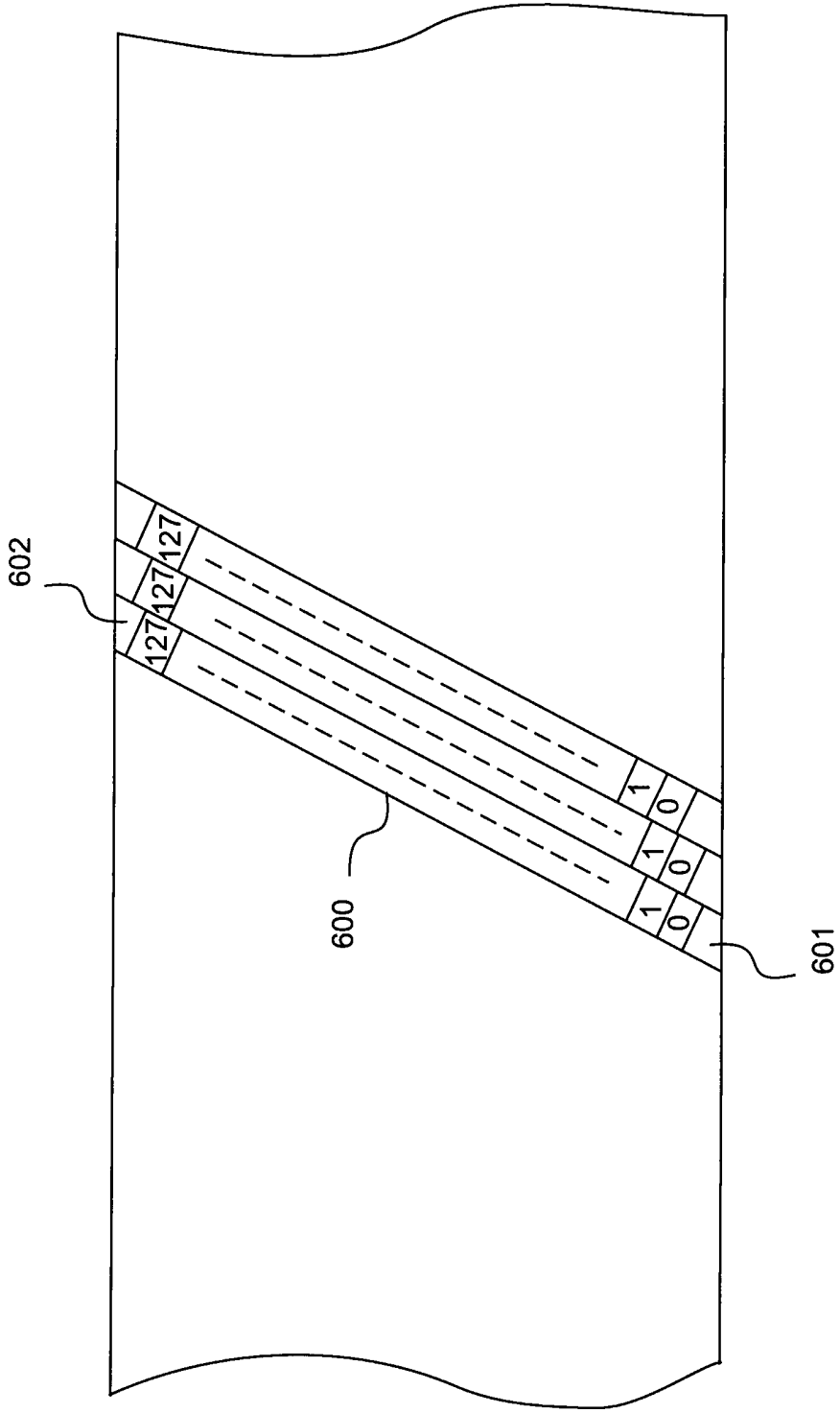

Fig. 6

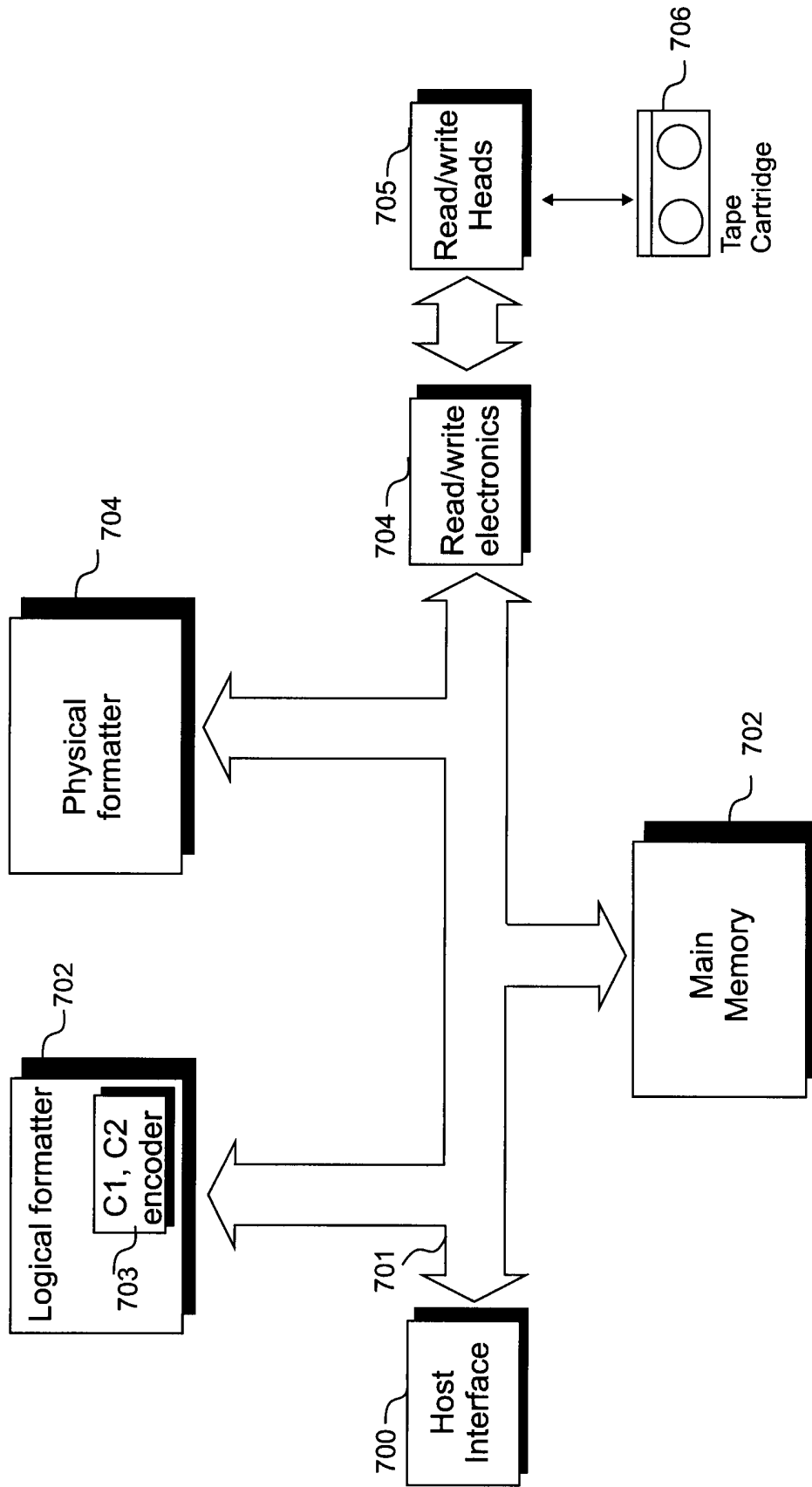

Fig. 7

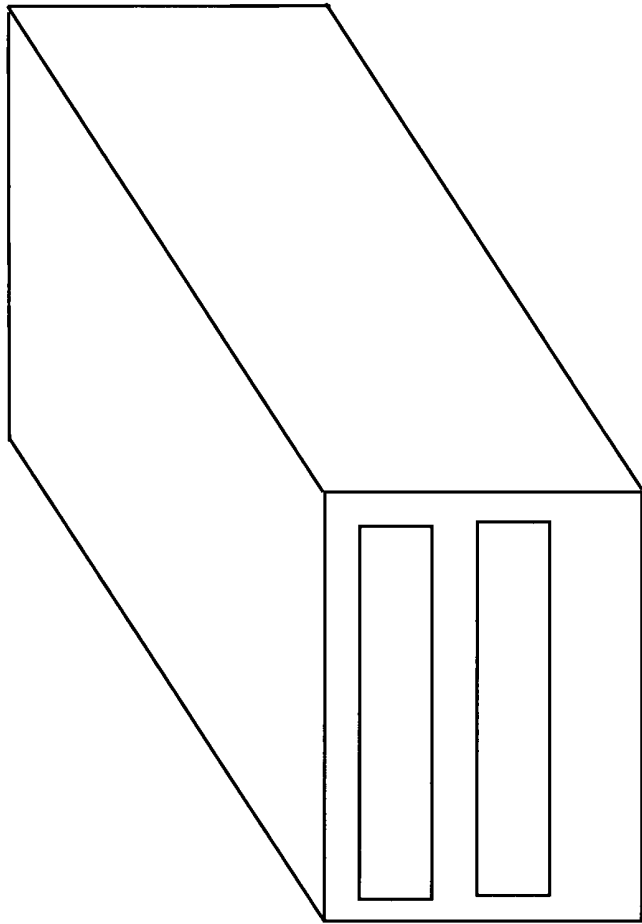

Fig. 8

LOGICAL DATA GROUPING IN DIGITAL STORAGE SYSTEM

Field of the Invention

The present invention relates to formatting of data and particularly although
5 not exclusively to a method of writing data to a data storage medium, and to a
data processing apparatus for arranging data into a format.

Background to the Invention

10 Referring to Fig. 1 herein, a known data storage format for writing data to a
tape data storage medium has a logical data sub group 100 known as a 'G4 sub
group' comprising an array of bytes of data arranged in rows and columns, there
being 96 columns and 124 rows in a data group, each column being referred to
as a 'data fragment'. Each column comprises 124 bytes of data numbered 0 to
15 123. Each row comprises 96 bytes, numbered 0 to 95.

The data sub group has applied to it redundancy error correction coding
(ECC). The applied redundancy error correction coding, which may be for
example a Reed-Solomon coding, comprises 192 C1 code words, each column
20 comprising a pair of interleaved C1 code words; and 336 C2 code words,
extending over 112 of the rows. Each coded row comprises 3 interleaved C2
code words, each code word being of 32 bytes. Shown in Fig. 1 is an example of
first row 101, comprising an interleaving of 3 C2 code words in row 0, where
bytes of 3 code words A, B, C respectively of the first row are interleaved
25 alternately such that individual bytes are ordered A, B, C, A, B, C, along the row.
C2 code words of another 111 rows are arranged similarly

Since each column comprises 2 C1 code words, the G4 data sub-group
comprises $96 \times 2 = 192$ C1 code words. C1 code words run vertically down the
30 columns, whilst C2 code words run horizontally across rows of the array. Each C1
code word extends along the entire height of its column, and each C2 code word

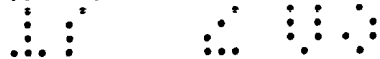

extends across the entire width of its row. The C2 code words occupy rows 0 – 111, so that there are $112 \times 3 = 336$ C2 code words in the G4 data sub-group.

5 Referring to Fig. 2 herein, the entire G4 data sub-group is stored on a magnetic tape data storage medium in a single track 200 extending transversely across a length of the tape as a stripe. In the prior art format, a physical width of the track a is $6.8\mu\text{m}$, the track density is 147 tracks/mm (3,735 tracks /inch), and the bit density of bits written along the tracks is 4,800 bits/mm (122,000 bits/inch). This results in a data storage capacity of 20 Gbytes of uncompressed data (40Gbytes at 2:1 compression ratio) on a single data storage cartridge,
10 containing a tape data storage medium of length 150 m. A mean time between failure (MTBF) reliability parameter of the prior art system, which is related to tape thickness, is 250,000 hours at a 30% duty cycle.

15 A plurality of tracks are written sequentially in parallel as the tape moves past a write head, the plurality of tracks abutting each other, so as to store a maximum amount of data on the tape. At a start of each track is provided a first synchronization tone 201 which allows a phase locked loop (PLL) to synchronize with the data. Similarly, at the end of each track is provided a second set of tones 202. The G4 data sub-group is stored between the first and second tone
20 regions in a single track, and extends across a width of the tape

Due to increased data storage demands, ongoing objectives in the improvement of tape data storage devices include:

25

- Increasing the amount of data which can be stored on a tape data storage medium;
- Increasing the data rate for writing data to a data storage medium;
- Improving reliability and byte error rates.

30

-

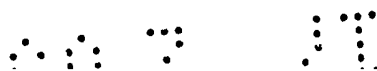

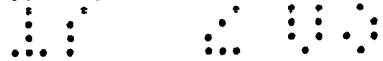

The above 3 parameters are interrelated, and attempts at increasing the amount of data storage capacity can affect the reliability of a tape data storage system.

5 **Summary of the Invention**

According to a first aspect of the present invention there is provided a method of formatting a block of user data, said method comprising:

10 arranging said block of user data into an array of bytes, said array comprising a plurality of rows and a plurality of columns of said bytes; and

 applying an error correction code to individual said rows of bytes, such that said error correction coded rows each comprise 4 code words.

15 According to a second aspect of the present invention there is provided a method of writing data to a linear tape data storage medium, said method comprising;

20 arranging a block of user data into a data group of a logical array of data bytes, comprising a plurality of rows of said data bytes and a plurality of columns of said data bytes;

 applying an error correction coding to individual ones of said rows, such that individual said rows are each arranged into 4 code words;

25 writing said data group as a data track extending across a width of said tape data storage medium such that all of said data group is contained within said single data track extending across said width of said tape data storage medium, and transverse to a main length of said tape data storage medium.

30

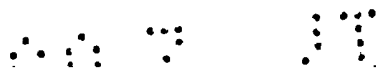

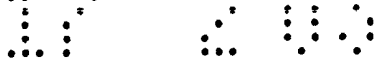

According to a third aspect of the present invention there is provide a data processing apparatus for arranging data into a format for writing to a data storage medium, said apparatus comprising:

5 a memory for storing a data group comprising a plurality of bytes of user data arranged logically in rows;

an error correction coding device for applying an error correction code to individual rows of said array, such that each said individual row is coded into 4
10 code words; and

a write head for writing each said data group across a width of a tape data storage medium, such that each said data group is written along a corresponding single track extending across a width of said tape data storage medium, and
15 transverse to a main length of said tape data storage medium.

According to a fourth aspect of the present invention there is provided a method of writing data to a linear tape data storage medium, said method comprising;

20 arranging a block of user data into a logical group of data bytes, comprising a plurality of rows of said data bytes and a plurality of columns of said data bytes;

25 applying an error correction code to said data group such that each said column of said data group is coded with 2 C1 code words;

applying an error correction coding to individual said rows, such that said individual rows are each arranged into 4 C2 code words; and

30



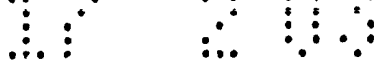

writing said data group in a single data track across a width of said tape data storage medium, such that all of said data group is contained within said single data track extending across said width of said tape data storage medium.

5 According to a fifth aspect of the present invention there is provided a tape data storage system comprising:

at least one write head for writing data to a magnetic tape data storage medium;

10

a transport mechanism for transporting said tape data storage medium past said write head;

15

a logical formatting device for formatting data into a data group comprising an array of bytes of data arranged logically in a plurality of rows and a plurality of columns;

a memory device for storing said logical array of data; and

20

an error correction coding device for applying an error correction code to individual said rows of bytes, such that said individual rows are each coded into 4 code words.

25

The invention includes a metal particle type tape data storage media cartridge comprising a band of elongate tape having:

width in the range 3.81 mm plus or minus 0.01 mm; and

length in the range 170m plus or minus 5m.

30



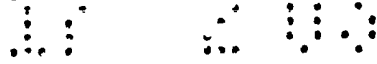

Brief Description of the Drawings

For a better understanding of the invention and to show how the same may be carried into effect, there will now be described by way of example only, specific embodiments, methods and processes according to the present invention with reference to the accompanying drawings in which:
5

Figure 1 schematically illustrates a prior art G4 data subgroup according to a known tape data storage format;

10 Figure 2 schematically illustrates a physical layout of a prior art G4 data sub-group written along individual corresponding respective tracks across a tape data storage medium, as is known in the art;

15 Figure 3 schematically illustrates a problem of variation of 'straightness' of a physical track written in a single stripe across a width of a tape data storage medium;

20 Figure 4 schematically illustrates a set of physical and practical considerations and limitations in achieving an overall increase in data storage capacity for a novel tape data storage system;

Figure 5 schematically illustrates a novel data sub-group according to a specific implementation of the present invention;

25 Figure 6 schematically illustrates a physical layout of a novel data sub-group written to tape along a data track;

30 Figure 7 schematically illustrates a data processing apparatus for creating a novel logical sub-group according to a specific implementation of the present invention; and



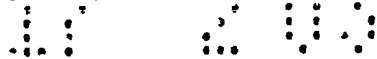

Figure 8 schematically illustrates in perspective view, an example of a tape drive unit according to a specific embodiment of the present invention.

Detailed Description of a Specific Mode for Carrying Out the Invention

5 There will now be described by way of example a specific mode contemplated by the inventors for carrying out the invention. In the following description numerous specific details are set forth in order to provide a thorough understanding of the present invention. It will be apparent however, to one skilled in the art, that the present invention may be practiced without limitation to
10 these specific details. In other instances, well known methods and structures have not been described in detail so as not to unnecessarily obscure the present invention.

As data storage densities on tape data storage media improve, making
15 further significant progress in increasing data storage capacity becomes increasingly difficult due to physical limitations of the tape data storage medium, and due to mechanical tolerances of tape transport components and read/write heads. Specific problems which can be encountered include the following:

20 Firstly, to increase bit density on a tape, means that each bit of data must physically occupy a smaller area of a magnetic coating of a magnetic tape data storage medium. Consequently, a reduction in signal to noise ratio can be expecting in reading data as the bit density on tape increases.

25 Secondly, in a helical scan system in which individual tracks of data are written as stripes transverse to main length of the tape and, across a width of an elongate tape data storage medium, by a rotating write head, if the width of tracks is decreased, then as well as encountering a reduction in signal to noise ratio due to the reduction in width of the track, there is also a tracking error problem in that
30 a read head is more difficult to align for reading a track, due to the reduced dimension of the track.



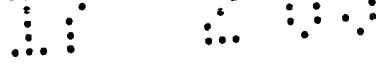

Thirdly, as track width decreases, there is an 'integration problem' where a different tape drive unit is used to read a tape data storage medium, compared to the tape drive unit which has been used to write data to the tape medium. Each tape drive unit tends to follow its own characteristic shape of path as its stripes data tracks across the tape. This means that data written by one tape drive unit may not be readable by another, nominally identical, tape drive unit.

Referring to Figure 3 herein there is schematically illustrated in exaggerated form, one example of a characteristic path 300 followed by a particular specific tape drive unit, compared to an ideal straight path 301, which represents a nominal path which every tape drive unit should follow when reading or writing a track across a width of tape data storage medium. As the track width is reduced, the tracking error due to a rotating read/write head following a path which deviates from the ideal straight path becomes more significant, since the amount of deviation of the actual tape drive specific path relative to the width of the ideal nominal track increases.

A particular tape drive unit may have its own characteristic curve as the track is written across the tape. Since each tape drive unit has a different respective characteristic curve for tracks which it reads or writes, tracks must be wide enough such that a track written by a first tape drive, having its own characteristic curve can be read by a second tape drive having a different characteristic curve. As the nominal width of tracks decreases, interchangeability problems between different devices increase.

25

Fourthly, there is problem of random byte errors, which increase as the signal to noise ratio decreases. In the prior art, C1 error correction coding is used to correct for random byte errors.

30

Fifthly, there is the problem of damage to a tape surface causing longer and non-random errors. In the prior art, C2 coding is used to alleviate the effect of



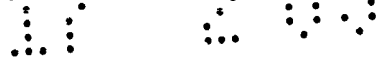

extended tape damage, which most commonly takes the form of elongate scratches running along a length of a tape data storage medium.

Referring to Figure 4 herein, there is illustrated schematically an interrelationship between parameters and limitations which need to be taken into consideration in achieving an overall increase in data storage capacity.

A total available increase in data storage capacity 400 is dependant upon the maximum allowable increase in tape length 401, the maximum allowable increase in track density 402, and any increases in capacity which can be achieved by significant re-organization of the logical sub-group, on the assumption that one sub-group will be written across a single width of tape, and the width of tape will not be significantly varied compared to the prior art tape width.

15

The allowable increase in tape length is limited by physical factors including the minimum tape thickness which can be achieved. The minimum tape thickness which can be achieved depends upon (1) substrate thickness and (2) the thickness of a magnetic material coating the substrate. In turn, the minimum practical substrate thickness which can be used depends upon reliability factors, and the type of substrate material which is being used.

20

Limitations on the substrate thickness are imposed by the design and tolerance of tape transport mechanisms. Varying the substrate thickness and substrate material also affects the reliability of the tape, particularly its susceptibility to edge defects and damage along the edge of the tape. Varying the thickness of magnetic media on the film affects the signal to noise ratio of a signal which can be read back from the tape, which also has the consequence, that thinner tapes require a re-design of tape drives to improve tolerances to make them able to read a lower signal to noise ratio signal.

30

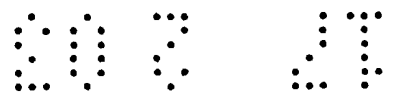

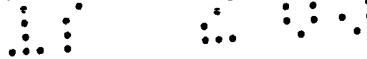

A determination of the allowable increase in track density 402 is limited by the problem of decreasing signal to noise ratio as the track density increases, and also the problem of interoperability of tape drive units and tape cassettes as the track width is reduced.

5

Re-organization of a data sub-group 403 has an implication for changing the bit density 404. In turn, a change in bit density has a corresponding change in signal to noise ratio 405. Changes in signal to noise ratio limit the allowable increase in track density, and the thickness of magnetic media on the film.

10

Changes to the structure of the logical sub-group therefore have a non-intuitive effect on the total available increase in capacity which is a non-linear relationship, since changing the logical structure of the data sub-group changes the bit density, and hence the signal to noise ratio which varies other parameters, in particular the allowable track density and physical characteristics of the tape, which dictate the allowable tape length. Each of these parameters, allowable track density and allowable increase in tape, also affect the total available increase in capacity 400.

15

20

According to a specific implementation of the present invention, an improved capacity tape data storage system is provided by the following combination of features.

- Tape data storage cartridges are provided, having a longer length of tape data storage medium, compared to a prior art cartridge. The tape length is increased by approximately 15% - 45% compared to the prior art cartridge. This involves reducing a thickness of tape substrate, and using a reduced thickness film of magnetic medium. Use of a reduced thickness magnetic film medium may provide a slightly worse signal to noise ratio than the prior art film, in the absence of any other changes in format. Further, reductions in substrate thickness may provide a different stretching characteristic compared

25

30



to prior art substrate. However, the disadvantages of reduced tape thickness are off-set by provision of a greater active surface area of tape within a cartridge.

5 • A width of data track is reduced compared to the prior art case. According to a specific embodiment of the present invention, data tracks have a nominal width of $5.4\mu\text{m}$, compared to the prior art in which a nominal track width of $6.8\mu\text{m}$ is employed. Reduction in track width, in isolation of other improvements, allows for an increase in data storage capacity for a same length of tape, of the order of 12%, since more tracks can be written per unit area of tape. However, reduction in track width carries with it a corresponding reduction in signal to noise ratio in reading from tape, and also tracking errors and interchangeability of a tape between different tape drive units is affected. Further, because there are a higher number of tracks written per unit length of tape than in the prior art case, physical damage to the tape, for example elongate scratches, for a same length of scratch will cause greater obliteration of data than in the prior art case, since there are more tracks per unit length than in the prior art case.

20

• A novel sub group data format.

In view of the above considerations, the inventors have been faced with the need to overcome a variety of problems and to find a technical solution which allows acceptable performance on each of the above itemised parameters of signal to noise ratio, leading to random bit errors; interchangeability between different tape drive units; and protection against the relatively increased effect of tape damage, in particular scratches or obliteration of data, whilst improving the overall data storage capacity.

30



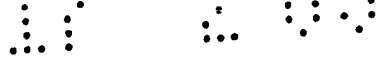

In order to increase capacity, there were several logical data formatting options available.

5 Firstly, more C1 code words (i.e. 3 or more) per fragment could have been incorporated, keeping the same number of bytes per C1 code word as in the prior art format. This would have entailed columns of length 186 bytes, 248 bytes, and so on, where each additional code word per fragment contains 62 bytes.

10 Secondly, the ratio of user data bytes to redundancy bytes per C1 code word could have been altered.

15 Thirdly, the ratio of user data bytes to parity bytes in the C2 code words could be varied, in order to give a higher proportion of user data, thereby increasing capacity, at the expense of a lower proportion of C2 parity bytes. However, in a case where all other parameters such as track width, and physical byte length on tape are unchanged, this would result in a lower level of error correction capability for tape damage or tape defects, since the amount of redundancy coding in each C2 code word is relatively reduced.

20 For each possible combination of changes of parameters in the sub data group, that is: changes to the ratio of user bytes to parity bytes within a C1 code word; changes to the number of C1 code words within a data fragment; changes to the relative ratio of user bytes to parity bytes within the C2 code word, this results in a different physical bit length, given that the whole data group is to be
25 written across a single track diagonally across the width of the tape. Each different bit length produces a corresponding respective signal to noise ratio, longer bit lengths giving a better signal to noise ratio compare to shorter bit lengths.

30 In order to improve data storage capacity, the density of bits written to tape must increase. However, if the bit density is increased too much, then the corresponding reduction in signal to noise ratio means that the readability of data



written to tape is reduced. Therefore, the bit density needs to be increased in a manner in which the effect of reduced signal to noise ratio on the re-readability of data from the tape remains within acceptable limits, such that the tape can be re-read by the same tape drive unit which wrote the data in the first place, and can be re-read by other tape drive units, being ones which did not originally write the data to a particular tape. In other words, interchangeability of tape drive units must be maintained and the signal to noise ratio of the data written to tape must be above a threshold level for achieving interoperability of tape drive units and tape data storage media.

10

A full and comprehensive analysis of variation in bit length, and consequent signal to noise ratio for each of the variable parameters of C1 code word byte ratio; C1 code word number per fragment; C2 byte ratio; and C2 code word number per row is complex and time consuming. However, as a result of an analysis, a solution as shown with reference to Fig. 5 was achieved, having 4 C2 code words per row.

15

As a result of experiments and analysis, the inventors have realised that an optimum solution for achieving increased capacity, within significantly degrading the interoperability of tape drive units and tape data storage media is to provide the logical data group format as described with reference to Fig. 5 herein.

20

The inventors have conceived a data format, after consideration of the above technical problems, which is now described as follows.

25

Referring to Fig. 5 herein, a novel data storage format according to a specific implementation of the present invention has a logical data group comprising an array bytes of data arranged in rows and columns, there being 128 columns in a sub data group numbered 0 to 127, each column being referred to as a 'data fragment', and 124 rows numbered 0 to 123. Each column comprises 124 bytes of data. Each row comprises 128 bytes of data.

30



The sub data group has applied to it redundancy error correction coding (ECC). The applied redundancy error correction coding may be for example a Reed-Solomon coding. Since each column comprises 2 C1 code words, the data sub-group comprises $128 \times 2 = 256$ C1 code words. Each column (data
5 fragment) comprising a pair of interleaved C1 code words. Each row comprises 4 interleaved C2 code words, each C2 code word being of 32 bytes.

C1 code words run vertically down the columns, whilst C2 code words run horizontally across rows of the array. Each C1 code word extends along the
10 entire height of its column, and each C2 code word extends across the entire width of its row. The C2 code words occupy rows 0 – 111, so that there are $112 \times 4 = 448$ C2 code words in the data sub-group.

Shown in Fig. 5 is an interleaving of 4 C2 code words in a first row (row 0),
15 where bytes of 4 code words A, B, C, D respectively of the first row are interleaved alternately as such that individual bytes are ordered A, B, C, D, A, B, C, D Rows 1 to 111 are similarly interleaved.

Referring to Fig 6 herein, the entire sub-group is stored on a magnetic tape
20 data storage medium in a single striped track 600 extending transversely across a length of the tape. A physical width a of the track is $5.4\mu\text{m}$ plus or minus $0.1\mu\text{m}$, giving a track density in the range 181 - 189 tracks/mm, and nominally 185 tracks/mm ($4,597 - 4,800.6$ tracks/inch, and nominally 4,699 tracks /inch). Each data fragment is written across a track with a bit density in the range 6,220 -
25 6,614 bits/mm, and nominally 6,417 bits/mm ($158,000 - 168,000$ bits/inch, and nominally 163,000 bits/ inch)

A plurality of tracks are written sequentially as the tape moves past a write
30 head, the plurality of tracks abutting each other so as to store a maximum amount of data on the tape.





At a start of each track is provided a first synchronization tone 601 which allows a phase locked loop (PLL) to synchronize with the data. Similarly, at the end of each stripe is provided a second set of synchronization tones 602. The data sub-group is stored between the first and second tone regions, and extends
 5 across a width of the tape in a straight line diagonally across a width of the tape.

The tape data storage medium itself comprises a single band of tape, having a length 170m plus or minus 5m. The tape is of a metal particle (MP) type, having an overall thickness of 5.3 μm plus or minus 0.02 μm . The tape comprises base
 10 film substrate having a thickness of 3.6 μm plus or minus 0.02 μm . A reverse side of the substrate is coated with back coating, and an upper side of the substrate is coated with an undercoat layer, and on top of the undercoat layer, there is formed a magnetic coating. The width of the tape is 3.81 mm plus or minus 0.01mm.

15 Initially, solutions which involved only increasing tape length and increasing track density, but without increasing byte density were investigated. However, moving from a 6.8 μm track width to a 5.4 μm track width, i.e. a 20% reduction in track width, for example means that the increased mechanical
 20 tolerances of the tape drive required to achieve interoperability of tape drive units and tape cartridges, would make such drives technically difficulty to produce, and uneconomic.

Further, using a longer tape length more than about 200 metres, in a single
 25 cartridge, means having a reduced tape substrate thickness, which increases interoperability problems, and introduces further problems in tape transport, which requires significant changes to tape drive mechanisms, again making tape drive units technically difficult to manufacture, and uneconomic. Using a thinner substrate, makes the tape more prone to damage at each edge of the tape.

30 Increasing capacity by a combination of increased tape length, and reduced track width, presents all of above problems in combination. Combining the finer



tolerances required for a thinner track width, with a tape having a thinner substrate, and therefore a less durable tape, which is much more subject to mechanical damage, particularly at the edges of the tape, then this dramatically decreases the interoperability of tape drive units and tape cartridges. Further, there is the problem of producing a thin enough film substrate to produce a tape of longer than approximately 200 meters length, to fit into a known format cartridge. As a practical matter, producing such a thin substrate film whilst achieving reliability of the tape is at present not feasible.

Consequently, achieving significant increases in data storage capacity by varying physical parameters of track length and track width (track density) alone does not give a high enough increase in data storage capacity over prior art systems of comparable size and weight. Increasing tape length and track density necessitates finer tolerances of tape drive units and tape data storage cartridges, which in turn, reduces the interoperability of tape drive units and cartridges, and also results in mechanical tolerances which are too high to produce a practical commercial tape data storage system.

The inventors examined varying the parameter of bit density, as a way of increasing data storage capacity. Constraints on increases in bit density arise from the logical format of a data sub-group, which is written in a single track striped across a width of tape. In a data sub-group which has applied to it error correction coding (ECC), a number of code words into which the data is subdivided can only be increased in integer units of one code word. Therefore, if the size of a data sub-group is to be increased by adding bytes, the number of bytes must correspond with an integer number of C1 and C2 code words. Therefore, in Fig. 5, extensions to the sub-group can be made by addition of an extra C2 code word per row, or one or more extra C1 code words per column (fragment). This has a consequence that byte length of bytes physically written to tape is not a continuously variable parameter, but is only variable in discrete steps, depending upon whether it is the number of C1 code words and/or C2 code words which is to be increased. Since bit density is directly related to signal to noise ratio, signal



to noise ratio is not a continuously variable design parameter, but can only be varied in discrete steps.

5 By selecting a C2 code word length of 32 bytes, the ratio of user data bytes to parity bytes is preserved, without reducing further the capability of the C2 error correction to rectify the same number of missing data bytes. Any reduction in C2 code word length would involve a lower ratio of user data bytes to parity data bytes, therefore reducing the interval in signal to noise ratio by reducing the C2 code word length would involve a corresponding reduction in data capacity within
10 each C2 code word.

Therefore, the variable parameters in selecting the data group format include variation of C2 code word length, variation of C1 code word length, each of which has an implication for efficiency of correctability of data, and an implication for
15 efficiency of data capacity within the code word; and the number of C1 code words in each data fragment (column), and the number of C2 code words in each row.

The length of the C2 code word cannot be reduced beyond a limit which is
20 dictated by the minimum length of scratches or other long defects along the tape, which must be correctable by the C2 code words. Each time a new C2 code word length is considered a full analysis of the correcting capability of that C2 code word type needs to be carried out.

25 Further, the minimum length of C2 code word is also limited by the proportion of user data to parity data within each C2 code word which is necessary in order to achieve optimum data storage capacity. Reductions in C2 code word length lead to a less efficient ratio of user data, or in other words shorter C2 code words produce proportionately less data storage capacity than
30 longer C2 code words.



Also, increasing the code word length involves additional hardware. For example taking an example of a 32 byte C2 code word, to get the same error correcting capability out of a 64 byte C2 code word. A code word which is more difficult to create in hardware or firmware is obtained, requiring hardware or
5 firmware which is more difficult to implement. Therefore, there is a technical disadvantage in increasing the C2 code word length. The longer the code word, the more powerful it becomes, but the harder it becomes to create in hardware or firmware. Therefore, a compromise needs to be made between increasing the length of code word in order to increase the error correction capability of that
10 code word, and between the additional difficulty in implementing a system for creating that code word in hardware and firmware.

Choosing the optimum values of C1 code word length, C2 code word length, number of C1 code words in a data fragment, and number of C2 code
15 words in a row requires detailed analysis, and a consideration of trade off's and optimizations. Arriving at a combination of C1 and C2 code word number and C1, C2 code word lengths which provides an optimum performance is a non-trivial task.

20 In order to achieve a significant increase in data storage capacity, for example to store 40Gbytes of uncompressed data on a single tape cartridge, (80 Gbytes at 2:1 compression ratio) requires an increase in density from the prior art density of 122Kbits per inch. In arriving at the specific implementation described herein, the C1 and C2 parameters including code word length and number of
25 code words was optimized, in order to give the required number of Kbits per inch of user data, in order to achieve the target capacity of a single tape data storage medium. There are various possible implementation options giving for example 36Gbytes, 38Gbytes, 40Gbytes or 45Gbytes uncompressed capacity on a single tape. However, each of these implementation options gives a different bit density,
30 and hence a different signal to noise ratio. Further, the relationship between signal to noise ratio and capacity is not intuitive, since to achieve each capacity requires a different C1/C2 combination, and a different ratio of parity bytes to user



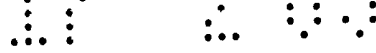

data bytes within the code words. Therefore, for example a data capacity of 36Gbytes on a single length of tape may give a worse signal to noise ratio than using an other combination of C1/C2 code words which gives 38Gbytes of data on a tape, due to the different overhead of the parity bytes within the specific
 5 choice of error correction coding used.

In the specific implementation described herein, bearing in mind the constraint that C2 code words can only be added or subtracted from rows in whole units of code words, then having selected a system using 4 code words
 10 per row, this enabled a tape data storage system having only a marginal increase in tape length, and only a relatively marginal decrease in track width to be utilized, to achieve a significant increase in overall data storage capacity to give of the order of 40Gbytes of uncompressed data storage on a single tape data storage medium. The signal to noise ratio resulting from the bit density was within
 15 a limit which could be processed on the basis of a practical manufactured tape data storage system. This has the advantage that a slight increase in tape length does not necessitate a complete re-design of the tape substrate and tape film, but rather, that tape re-design is a fine tuning exercise, rather than a fundamental re-design of the tape data storage medium itself. In the specific implementation
 20 adopted, the tape data storage medium is thinner than the prior art tape, however the reduction in thickness is small enough such that it has been achieved by a reduction in magnetic film media thickness rather than a reduction in the thickness of the substrate material itself metal particle (MP) type tape can be used.

25

If, on the other hand if 5 code words per row had been used, then this would have necessitated using a metal evaporated (ME) type tape in order to achieve the required byte density and signal to noise ratio.

30

Referring to Fig. 7 herein, there is schematically illustrated a tape data storage system, according to a specific implementation of the present invention. The tape data storage system comprises: a host interface 700 for receiving user



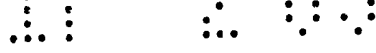

data from a host device, for example a host computer; an internal data bus 701; a main memory buffer 702 for storing user data whilst it is being formatted and error correction coded; a logical formatter device 702 which operates to arrange an incoming stream of host data into logical 2 dimensional arrays of data as described with a reference to Fig. 5 herein, the logical formatter comprising an error correction encoder 703 for applying an error correction code to rows and columns of each data sub group as described herein before; a physical formatter 704 for formatting logical data groups into a continuous stream of data fragments for writing as physical data tracks, there being 128 data fragments per physical data track; a read/write component 704 for writing data to at least one read/write head 705, and conversely, for reading data for accepting data from at least one read head; and one or a plurality of tape data storage cartridges 706, each containing a length of elongate magnetic tape data storage medium.

The write heads operate to write a plurality of data tracks sequentially along a length of the tape, each physical track being written as a stripe across a width of the tape as described with reference to Fig. 6 herein. The elongate tape data storage medium contained in the cartridge 706 has a length of the order 170m plus or minus 5m, a width of the order 3.81mm plus or minus 0.01mm; a tape thickness of the order 5.3 μ m, of which a substrate thickness is of the order of 3.6 μ m.

Referring to Figure 8 herein, the tape data storage system as described with reference to Fig.7 herein, may be implemented as a discrete stand alone tape drive unit, having its own casing, power supply, and connections.

In other embodiments, the tape data storage system may be implemented within a host computer or other computer entity within a same casing as the host computer or other computer entity.



Claims:

1. A method of formatting a block of user data, said method comprising:

5

arranging said block of user data into an array of bytes, said array comprising a plurality of rows and a plurality of columns of said bytes; and

applying an error correction code to individual said rows of bytes, such that said error correction coded rows each comprise 4 code words.

10

2. The method as claimed in claim 1, further comprising:

in each of said error correction coded rows, interleaving a corresponding said 4 code words, such that each code word extends along substantially an entire length of said row.

15

3. The method as claimed in claim 1, further comprising:

in each of said error correction coded rows, interleaving a corresponding said 4 code words, such that each code word extends along substantially an entire length of said row; and

20

such that in each row, a first code word, a second code word, a third code word, and a fourth code word are interleaved in an order of a byte of said first code word, a byte of said second code word, a byte of said third code word and a byte of said fourth code word, said interleaved order repeating along said row.

25

4. The method as claimed in any one of the preceding claims, wherein each said row comprises 128 bytes.

30



5. The method as claimed in any one of the preceding claims, wherein each said column comprises 124 bytes.

6. The method as claimed in any one of the preceding claims, wherein
5 each said column comprises a pair of code words.

7. The method as claimed in any one of the preceding claims, wherein
each said column comprises a pair of code words, said pair of code words being
interleaved with each other.

10

8. The method as claimed in any one of the preceding claims,
wherein:

each said row comprises 4 C2 code words; and

15

each said column comprises 2 C1 code words.

9. A method of writing data to a linear tape data storage medium, said
method comprising;

20

arranging a block of user data into a data group of a logical array of data
bytes, comprising a plurality of rows of said data bytes and a plurality of columns
of said data bytes;

25

applying an error correction coding to individual ones of said rows, such
that individual said rows are each arranged into 4 code words;

30

writing said data group as a data track extending across a width of said
tape data storage medium such that all of said data group is contained within said
single data track extending across said width of said tape data storage medium.



10. The method as claimed in claim 9, wherein said data group comprises 448 C2 code words.

11. The method as claimed in claim 9 or 10 further comprising:

5

applying an error correction coding to columns of said data group such that each said column comprises 2 code words.

12. The method as claimed in any one of claims 9 to 11, wherein said data group comprises 256 C1 code words.

10

13. The method as claimed in any one of claims 9 to 12, wherein said data track has a width in the range $5.4\mu\text{m}$, plus or minus $0.1\mu\text{m}$.

14. The method as claimed in any one of claims 9 to 13, wherein said data is written to tape at a bit density in the range 6,220 to 6,614 bits/mm.

15

15. Data processing apparatus for arranging data into a format for writing to a data storage medium, said apparatus comprising:

20

a memory for storing a data group comprising a plurality of bytes of user data arranged logically in rows;

an error correction coding device for applying an error correction code to individual rows of said array, such that each said individual row is coded into 4 code words; and

25

a write head for writing each said data group across a width of a tape data storage medium, such that each said data group is written along a corresponding single track extending across a width of said tape data storage medium, and transverse to a main length of said tape data storage medium.

30

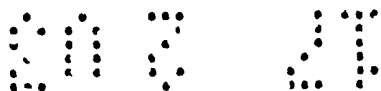

16. A data processing device for arranging data into a format of an array of bytes arranged in rows and columns, said device comprising:

5 a memory for storing a logical array comprising a said plurality of bytes of user data arranged logically in a plurality of rows and a plurality of columns; and

10 an error correction coding device for applying an error correction code to individual said rows of bytes, such that said individual rows are each coded into 4 code words.

17. The data processing device as claimed in claim 16, wherein:

15 said error correction coding device is operable for applying an error correction code to each said column of bytes, such that each said column is coded into 2 code words.

18. The data processing device as claimed in claim 16, wherein:

20 individual said rows of bytes are coded into 4 code words, said code words being interleaved with each other, such that each said code word of a row extends substantially along a whole length of said row.

19. A method of writing data to a linear tape data storage medium, said method comprising;

25

arranging a block of user data into a logical group of data bytes, comprising a plurality of rows of said data bytes and a plurality of columns of said data bytes;

30

applying an error correction code to said data group such that each said column of said data group is coded with 2 C1 code words;



applying an error correction coding to individual said rows, such that said individual rows are each arranged into 4 C2 code words; and

5 writing said data group in a single data track across a width of said tape data storage medium, such that all of said data group is contained within said single data track extending across said width of said tape data storage medium.

20. A tape data storage system comprising:

10 at least one write head for writing data to a magnetic tape data storage medium;

a transport mechanism for transporting said tape data storage medium past said write head;

15 a logical formatting device for formatting data into a data group comprising an array of bytes of data arranged logically in a plurality of rows and a plurality of columns;

20 a memory device for storing said logical array of data; and

an error correction coding device for applying an error correction code to individual said rows of bytes, such that said individual rows are each coded into 4 code words.

25 30 21. The data storage system as claimed in claim 20, wherein said at least one write head operates to write a plurality of said arrays of data to a corresponding respective plurality of data tracks, each data track extending diagonally across a width of said tape data storage medium, wherein each said data track is written with a corresponding respective said array.



22. The data storage system as claimed in claim 20 or 21, further comprising a tape data storage media comprising a band of elongate tape of:

width in the range 3.81 mm plus or minus 0.01 mm; and

5

length in the range 170m plus or minus 5m.

23. A metal particle type tape data storage media cartridge comprising a band of elongate tape having:

10

width in the range 3.81 mm plus or minus 0.01 mm; and

length in the range 170m plus or minus 5m.

15

24. The tape data storage media cartridge as claimed in claim 23, having a thickness in the range 5.3 μ m plus or minus 0.02 μ m.

20



Application No: GB 0301803.3
Claims searched: 1-22

Examiner: Pierre Oliviere
Date of search: 24 September 2003

Patents Act 1977 : Search Report under Section 17

Documents considered to be relevant:

Category	Relevant to claims	Identity of document and passage or figure of particular relevance
X	1-3, 6-9, 11, 15-21 at least	US 4477903 A (SCHOUHAMER IMMINK) Figure 2 and related description.
X	1-3, 6-9, 11, 15-21 at least	US 4413340 A (ODAKA) Columns 5 and 6.
X	1-3, 6-9, 11, 15-21 at least	US 6311305 B1 (SOLLISH) Column 6.
X	1-3, 6-9, 11, 15-21 at least	EP 0551973 A2 (AMPEX) Column 5, lines 28 to column 6, line 12 and claim 10.
A		EP 0957484 A1 (HEWLETT-PACKARD)

Categories:

X Document indicating lack of novelty or inventive step	A Document indicating technological background and/or state of the art.
Y Document indicating lack of inventive step if combined with one or more other documents of same category.	P Document published on or after the declared priority date but before the filing date of this invention.
& Member of the same patent family	E Patent document published on or after, but with priority date earlier than, the filing date of this application.

Field of Search:

Search of GB, EP, WO & US patent documents classified in the following areas of the UKC^v:

G4A, G5R

Worldwide search of patent documents classified in the following areas of the IPC⁷:

G06F, G11B

The following online and other databascs have been used in the preparation of this search report:

WPI, EPODOC, PAJ, TXTE, INSPEC