

(19) World Intellectual Property Organization
International Bureau



(43) International Publication Date
13 December 2001 (13.12.2001)

PCT

(10) International Publication Number
WO 01/94118 A1

- (51) International Patent Classification⁷: **B41J 3/28, 3/46** (81) Designated States (*national*): AE, AG, AL, AM, AT, AT (utility model), AU, AZ, BA, BB, BG, BR, BY, BZ, CA, CH, CN, CR, CU, CZ, CZ (utility model), DE, DE (utility model), DK, DK (utility model), DM, DZ, EE, EE (utility model), ES, FI, FI (utility model), GB, GD, GE, GH, GM, HR, HU, ID, IL, IN, IS, JP, KE, KG, KP, KR, KZ, LC, LK, LR, LS, LT, LU, LV, MA, MD, MG, MK, MN, MW, MX, MZ, NO, NZ, PL, PT, RO, RU, SD, SE, SG, SI, SK, SK (utility model), SL, TJ, TM, TR, TT, TZ, UA, UG, US, UZ, VN, YU, ZA, ZW.
- (21) International Application Number: PCT/SE01/01307
- (22) International Filing Date: 8 June 2001 (08.06.2001)
- (25) Filing Language: English
- (26) Publication Language: English
- (30) Priority Data:
0002175-8 9 June 2000 (09.06.2000) SE (84) Designated States (*regional*): ARIPO patent (GH, GM, KE, LS, MW, MZ, SD, SL, SZ, TZ, UG, ZW), Eurasian patent (AM, AZ, BY, KG, KZ, MD, RU, TJ, TM), European patent (AT, BE, CH, CY, DE, DK, ES, FI, FR, GB, GR, IE, IT, LU, MC, NL, PT, SE, TR), OAPI patent (BF, BJ, CF, CG, CI, CM, GA, GN, GW, ML, MR, NE, SN, TD, TG).
- (71) Applicant (*for all designated States except US*): **PRINT DREAMS EUROPE AB** [SE/SE]; Norgegatan 1, S-164 32 Kista (SE).
- (72) Inventor; and
- (75) Inventor/Applicant (*for US only*): **WALLING, Alex** [MX/SE]; Lindevägen 128, S-120 48 Enskede Gård (SE).
- (74) Agent: **EHRNER & DELMAR PATENTBYRÅ AB**; Box 103 16, S-100 55 Stockholm (SE).
- Published:
— with international search report
— before the expiration of the time limit for amending the claims and to be republished in the event of receipt of amendments

[Continued on next page]

(54) Title: METHOD AND HANDHELD DEVICE FOR PRINTING

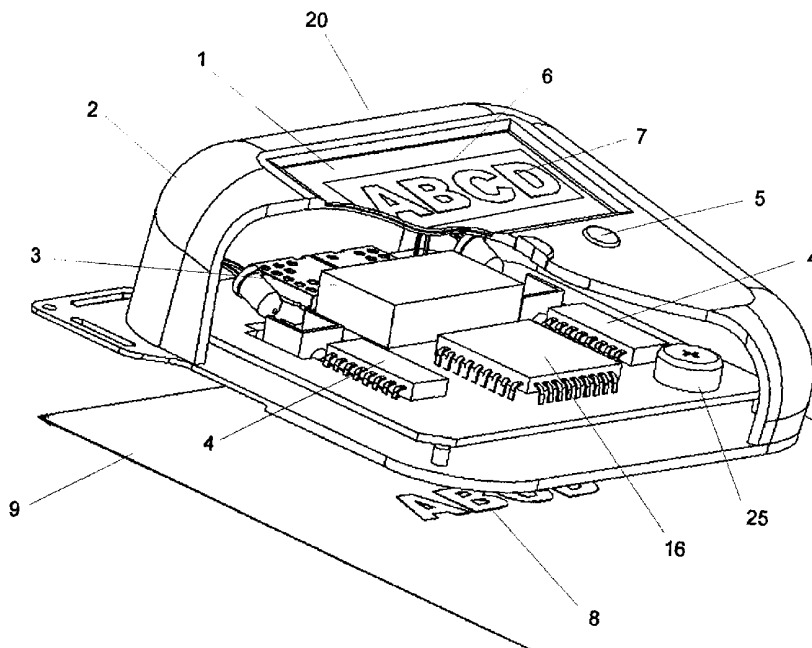

(57) Abstract: Method and device for printing, comprising a graphical screen (1) built into a handheld printing device (20) where the automatic steering of the print head has been replaced by manual steering aided by one or more positioning sensors (4), co-operating with a micro controller circuit (16). The graphical screen (1) comprises a "virtual" window (6) showing a dynamic image (7) corresponding in position at each moment to the printout in progress (8), and serving to enable a real-time supervision of the printing process.



WO 01/94118 A1



For two-letter codes and other abbreviations, refer to the "Guidance Notes on Codes and Abbreviations" appearing at the beginning of each regular issue of the PCT Gazette.

Method and handheld device for printing**Field of the invention**

The invention relates to a method and device of the kind
5 defined in the preamble of claim 1 and claim 8, respectively.

Background of the invention

Conventional printers of today operate with automatic feed,
where the print head moves over the printout surface in a
10 predetermined pattern. This is a drawback, since the print
head has to sweep over the entire printout surface even if it
is to be active only in relatively small areas, such as for
example, the lower right-hand corner of the printout.

15 A further drawback with conventional printers is their great
size, which means that they are more or less stationary.

Objects of the invention

A main object of the invention is to provide a method and
20 device for performing an accurate and high-quality printout
with a handheld printing device with no mechanisms for
automatic feed of a printing paper or automatic steering of a
print head.

25 Another object of the invention is to enable a convenient
start of the whole printout with great precision.

Summary of the invention

The main object is achieved by a method and device as defined
30 in claim 1 and claim 8, respectively.

Thus, the invention concerns a method and device for printing,
comprising a graphical screen through which a non-automatic

printing process can be supervised, in particular a method where the user steers the entire device by hand over the printing surface. The automatic steering of a print head has thus been replaced by manual movements. This enables a faster
5 printout, especially for printouts having text or images spread out over the printout surface with much empty space in between. The print head can be moved by hand directly to the area where the text or image is to be printed.

10 The manual movement is facilitated by the graphical screen on the device showing at each moment a portion of the picture corresponding in position to the printout in progress. This is accomplished by one or more positioning sensors co-operating with a micro controller circuit.

15 By designing a "virtual" window in the screen, where a dynamic picture corresponding to the actual printout is re-created, a feeling of seeing right through the screen and directly onto the printing paper is accomplished. In this way, the printout
20 process can be supervised effectively in real-time.

The parts of the printout which have not yet been completed can preferably be re-created as contours that are filled in gradually as the print head passes the current areas.

25 In this way, the printing process is supervised in a more accurate and controlled way.

The other object of the invention, i.e. to enable a convenient
30 start of the whole printout with great precision, is achieved by showing an easily recognisable part of the picture, e.g. the upper left-hand corner of the printout, on the screen. The device can then be positioned exactly where the printout is to

be started. Then the printout may be started by means of a push button.

As a supplement to the "virtual" window on the screen, a group
5 of 4-8 arrows may be shown beside it. These arrows are intended to guide the user where to lead the printing device for the printout to be accomplished faster.

Another supplementary graphic may be a status section that can
10 show how much, expressed as a percentage, of the printout that is finished, and also what process is in progress at each moment.

The invention will now be explained further below, way of
15 examples, with reference to the accompanying drawings.

Brief description of the drawings

Fig 1 shows a perspective view of the printing device with a
screen according to the invention, a portion of the housing
20 being cut away for clarity.

Fig 2 shows a perspective view from underneath of the printing
device comprising a screen according to the invention.

25 Fig 3 shows, likewise in a perspective view, the front of the printing device of figs. 1 and 2.

Fig 4 shows, in a schematic view from the front, a modified
embodiment of the screen of the device.

30

Fig 5 shows, in a schematic view from the front, a further
embodiment of the screen of the device.

Fig 6 shows, in a perspective view, a second embodiment of the printing device according to the invention.

Detailed description of preferred embodiments

5 In fig 1, there is shown a screen 1 built into a handheld printing device 20 comprising a print head 3 co-operating with one or more positioning sensors 4, a micro controller circuit 16 and one or more command buttons 5. The print head may be an ordinary ink-jet printer, e.g. a piezo jet printer Model Xaar
10 Jet128, available from XaarJet. Alternatively, a bubble jet print head could be used. The screen 1 is preferably an OLED (Organic Light Emitting Diodes), available from for example RITEK Display Technology, but could be an ordinary LCD (Liquid Crystal Display) or a TFT (Thin Film Technology). OLEDs are
15 preferred since they have fast response times.

The printing device according to the present invention also includes a housing 2 (preferably made of a plastic material, but could of course be of any other suitable material),
20 mounted on a bottom plate 21. The bottom plate has openings for the print head 3 and one or more sensors 4. The bottom plate 21 is not of uniform thickness, but is divided into two parts. The part of the bottom plate 21 that includes the opening for the print head 3 is somewhat thinner than the rest
25 of the plate, in order to create sufficient space for the print head 3 when it is printing. The other part of the bottom plate 21 is in contact with the printing surface 9. The printing device may be battery operated, in which case a battery 25 is included. Alternatively, the printing device 20
30 could be wire-lined or wireless fed, in which case outputs for this should be included (not shown).

In the embodiment in accordance with fig 1, the screen 1 includes a "virtual" window 6 where a dynamic image 7 of the printout in progress (a portion of the picture to be printed) is re-created. The image 7 corresponds to the picture in progress 8 on the printing surface 9 both as regards position and scale.

The positioning sensors 4 register in real-time where the printing device 20 and thus the print head 3 is located during the whole printing process. The sensors used could for example be HDNS-2000, available from Agilent Technologies. By means of data received from the positioning sensors, the micro controller circuit is then able to calculate exactly how the image 7 in the window 6 should look at each separate moment. The result will be such that the image 7 is perceived as totally fixed to the surface 9 even when the printing device 20 is moved around.

Fig 2 shows the printing device 20 from underneath, illustrating particularly the print head 3 and the positioning sensors 4, there being two such sensors in the illustrated embodiment.

The bottom plate 21 may include a corner portion 22 projecting outwardly a bit, as shown in fig. 2. In fig. 2 this portion is shown having a hole 23 in its edge and two slits 24 along the sides. These are helpful in positioning the printout at the surface. When doing so, the hole 23 is placed so that, for example, the upper left-hand corner of the printing surface is visible through it, whereas the slits are placed along the sides of the surface. Thereby a more accurate positioning of the printout at the surface is accomplished.

In fig 3 the activated screen 1 is shown comprising a static preview of for example the upper left corner of the printout 7. The intent is that the user should be able to place the printing device 20 so that the particular corner is used as a reference point in order to more precisely position the printout 7 in advance at the surface 9. The printing process may thereafter begin with a push on one of the buttons 5.

In the embodiment according to fig 4, the screen 1 has been supplemented with a set of graphical arrows 10 designed to guide the user to where the printing device 20 should be moved next. This is done in order to speed up and facilitate the printing process.

By means of a computer program, taking into consideration where the print head 3 has been active, it is possible to retrieve so called white spots on the printout 8, and then build up a recommendation in the form of blinking graphical arrows 10 showing the direction in which the user should move the print head 3.

The same algorithms may be used in order to initially show the image 7 in the window 6 only as simple, not filled-in contours 11, which are subsequently filled in gradually as the print head 3 passes over the particular areas on the printing surface 9.

The embodiment according to fig 4 also shows an optional status field 12 illustrating by means of figures and/or graphics 13, how much - expressed as a percentage - of the printout 8 that remains. This can be combined with a setting where one states at which percentage level the printout 8 is to be considered finished. Other relevant information, such as

the size of paper 19 to be used for the printout or what process is in progress at each moment, may also be shown at the side.

5 The embodiment according to fig 5 shows how the image 7 may be configured in order to agree in position with the printout in progress 8, although it is shown in size as a whole printout page 17 in the window 6. The print head 3 is represented as a dynamic rectangle 18 moving over the printout page 17 as the
10 user moves the printing device 20 over the printing surface 9.

Fig 6 shows the screen 1 according to the invention built into a simpler form of a printing device 20' intended for printing very short text lines or simpler graphic, that is, the same
15 type of tasks that are today performed by different kinds of stamps and the like.

In this embodiment, the device 20' is first positioned on the printing surface by the same procedure as described above,
20 that is, by showing a preview of a corner of the printout image 7 on the screen, whereupon the device is placed at the desired position on the surface 9, and the printing is effected.

25 In the embodiment according to fig 6, the window 6 may advantageously be used to show a "virtual" strip 14, containing a plurality of predetermined printout alternatives stored on some kind of electronic memory. By means of navigation buttons 15, the user may easily browse to the
30 desired printout alternative.

Claims

1. A method for operating a handheld printing device having a
5 print head for printing at least one predetermined picture
(7) on a printout surface (9) **characterised in** that the
entire printing device with the print head is manually
steered over said printout surface (9) with the aid of one
or more positioning sensors (4) co-operating with a micro
10 controller circuit (16), such that a graphical screen (1)
on the device shows at each moment a portion of said
picture (7) corresponding in position to the printout in
progress (8).
- 15 2. A method as claimed in claim 1 **characterised in** that said
portion of said picture (7) is shown in a window (6) on
said screen (1), said portion being the portion located
underneath the print head (3) and its close vicinity.
- 20 3. A method as claimed in claim 1 or 2 **characterised in** that
the not finished parts of the printout in progress (8), at
a given moment, are represented as simple contours (11),
which are filled in as the print head (3) passes over these
particular parts of the printout (8).
- 25 4. A method as claimed in any one of claims 1-3 **characterised**
in that a whole printout page (17) is represented on the
screen (1), and that a dynamic rectangle (18) visualising
the print head (3) moves over the screen (1) as the user
30 moves the printing device (20) over said printout page
(17).

5. A method as claimed in any one of claims 1-3 **characterised in** that a preview of an easily recognised part of the complete printout is shown on the screen (1), and that the easily recognised part is used as a reference point for positioning the printout (8) on the printout surface (9).
5
6. A method as claimed in any one of the preceding claims **characterised in** that a set of graphical arrows (10) are used to indicate to the user where to move the printing device (20) at a given moment.
10
7. A method as claimed in any of the preceding claims **characterised in** that a portion (14) of said screen (1) shows possible choices among a number of printout alternatives, and that a particular printout or a programmable printout can be selected by means of one or more navigation buttons (15).
15
8. A handheld printing device (20) with a print head (3) for printing at least one predetermined picture (7) on a printout surface (9), **characterised in** that the device comprises a graphical screen (1) and one or more positioning sensors (4) co-operating with a micro controller circuit (16), such that, at each moment, a portion of said picture is shown on the screen (1) corresponding in position to the printout in progress (8).
20
25
9. A handheld printing device as claimed in claim 8, **characterised in** that the device further comprises a set of graphical arrows (10) to indicate to the user where to move the printing device (20) at a given moment.
30

10. A handheld printing device as claimed in claim 8 or 9,
characterised in that the device further comprises a status
field (12) for indicating relevant information, such as how
much of the printout (8) that remains, size of paper (19)
5 to be used for the printout or what process is in progress
at each moment.

Fig. 1

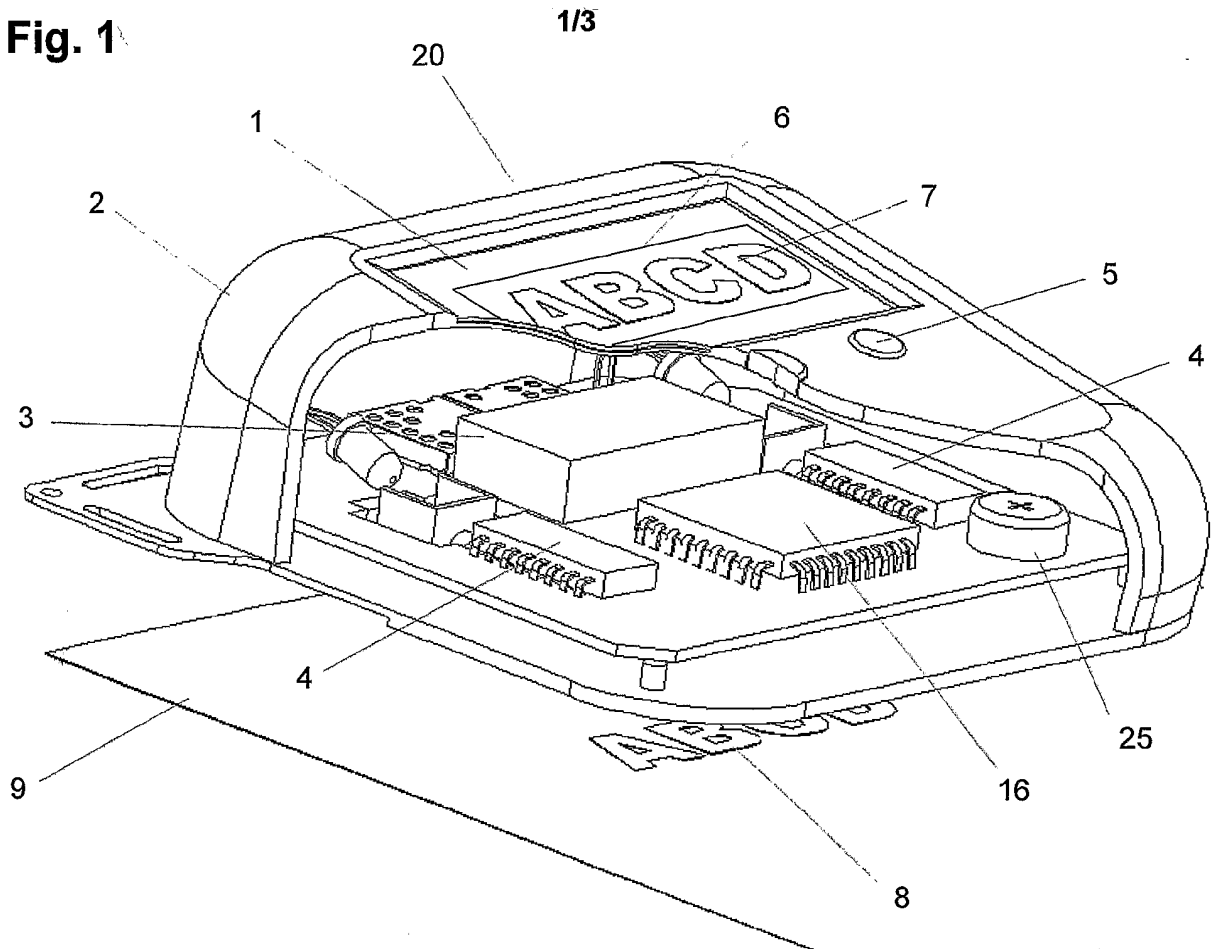

Fig. 2

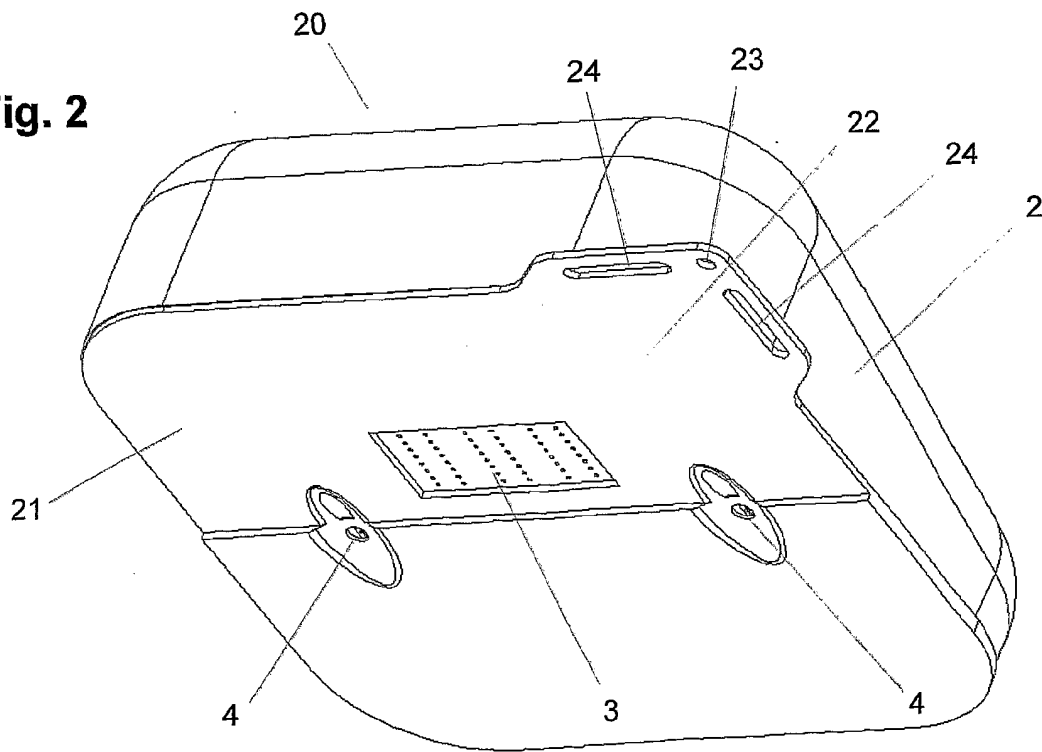

Fig. 3

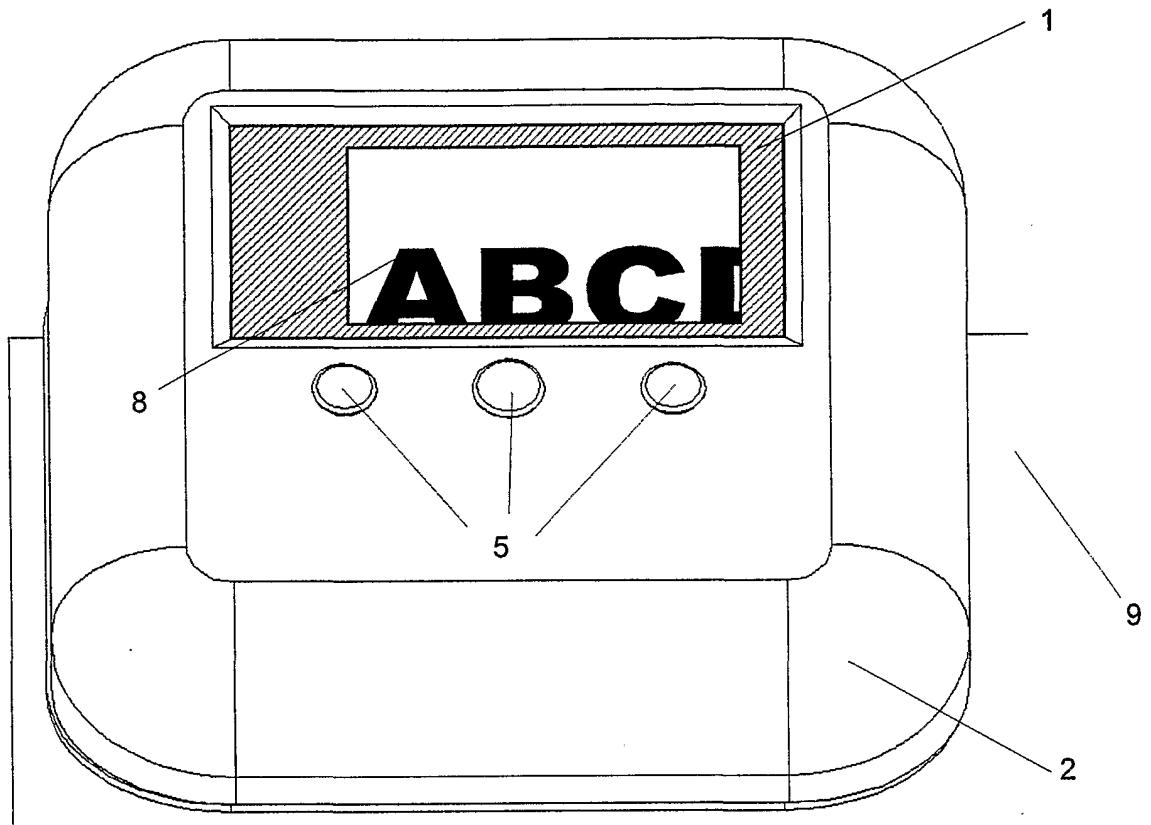

Fig. 4

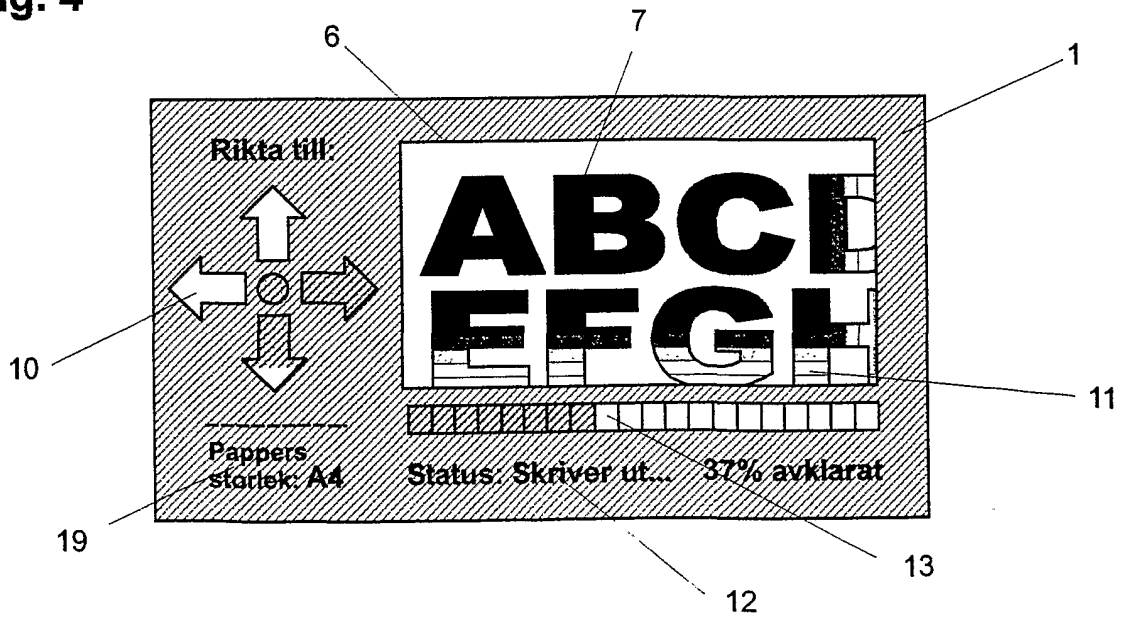

Fig. 5

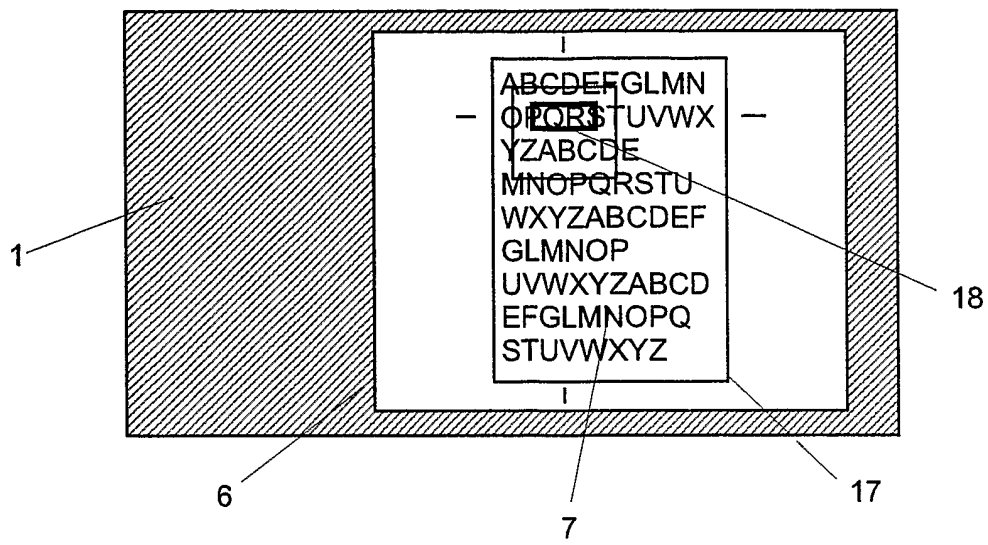
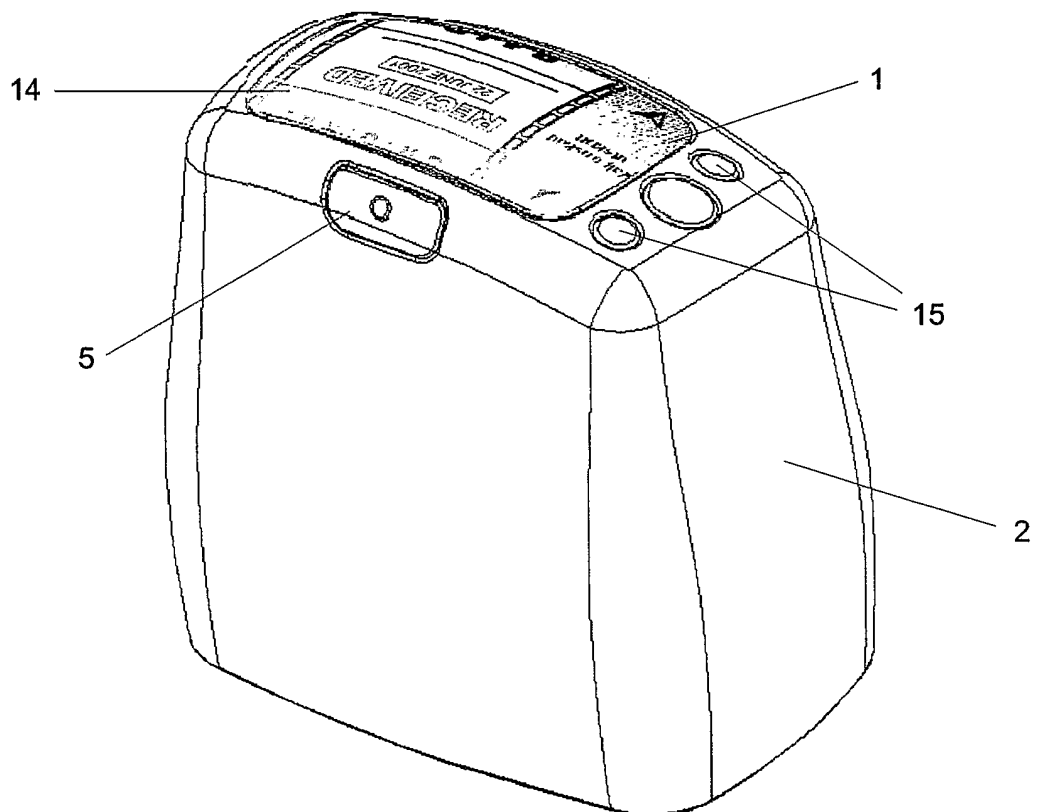

Fig. 6



INTERNATIONAL SEARCH REPORT

International application No.

PCT/SE 01/01307

A. CLASSIFICATION OF SUBJECT MATTER

IPC7: B41J 3/28, B41J 3/46

According to International Patent Classification (IPC) or to both national classification and IPC

B. FIELDS SEARCHED

Minimum documentation searched (classification system followed by classification symbols)

IPC7: B41J

Documentation searched other than minimum documentation to the extent that such documents are included in the fields searched

SE,DK,FI,NO classes as above

Electronic data base consulted during the international search (name of data base and, where practicable, search terms used)

WPI DATA

C. DOCUMENTS CONSIDERED TO BE RELEVANT

Category*	Citation of document, with indication, where appropriate, of the relevant passages	Relevant to claim No.
A	GB 2343656 A (ESSELTE N.V.), 17 May 2000 (17.05.00) --	1-10
A	US 5024541 A (S.TSUKADA ET AL), 18 June 1991 (18.06.91) -----	1-10

Further documents are listed in the continuation of Box C. See patent family annex.

* Special categories of cited documents:	"I" later document published after the international filing date or priority date and not in conflict with the application but cited to understand the principle or theory underlying the invention
"A" document defining the general state of the art which is not considered to be of particular relevance	"X" document of particular relevance: the claimed invention cannot be considered novel or cannot be considered to involve an inventive step when the document is taken alone
"E" earlier application or patent but published on or after the international filing date	"Y" document of particular relevance: the claimed invention cannot be considered to involve an inventive step when the document is combined with one or more other such documents, such combination being obvious to a person skilled in the art
"L" document which may throw doubts on priority claim(s) or which is cited to establish the publication date of another citation or other special reason (as specified)	"&" document member of the same patent family
"O" document referring to an oral disclosure, use, exhibition or other means	
"P" document published prior to the international filing date but later than the priority date claimed	

Date of the actual completion of the international search	Date of mailing of the international search report
9 October 2001	11-10-2001

Name and mailing address of the ISA/ Swedish Patent Office Box 5055, S-102 42 STOCKHOLM Facsimile No. +46 8 666 02 86	Authorized officer Jan Silfverling /itw Telephone No. +46 8 782 25 00
--	---

INTERNATIONAL SEARCH REPORT

Information on patent family members

International application No.

01/10/01

PCT/SE 01/01307

Patent document cited in search report	Publication date	Patent family member(s)	Publication date
GB 2343656 A	17/05/00	AU 6357499 A DE 29923983 U EP 1128965 A GB 9825018 D WO 0029221 A	05/06/00 12/07/01 05/09/01 00/00/00 25/05/00
US 5024541 A	18/06/91	JP 2544128 B JP 63224616 A JP 2827200 B JP 63224568 A JP 63224895 A JP 2106255 C JP 8015007 B JP 63236211 A JP 63234524 A JP 2503506 B JP 63274567 A	16/10/96 19/09/88 18/11/98 19/09/88 19/09/88 06/11/96 14/02/96 03/10/88 29/09/88 05/06/96 11/11/88