

(19) World Intellectual Property Organization
International Bureau



(43) International Publication Date
24 September 2009 (24.09.2009)

(10) International Publication Number
WO 2009/115889 A1

- (51) **International Patent Classification:**
B25B 23/142 (2006.01)
- (21) **International Application Number:**
PCT/IB2009/000527
- (22) **International Filing Date:**
12 March 2009 (12.03.2009)
- (25) **Filing Language:** Italian
- (26) **Publication Language:** English
- (30) **Priority Data:**
MI2008A000462 18 March 2008 (18.03.2008) IT
- (71) **Applicant (for all designated States except US):** ATLAS COPCO BLM S.R.L. [IT/IT]; Via Pepe, 11, I-20037 Paderno Dugnano (IT).
- (72) **Inventor; and**
- (75) **Inventor/Applicant (for US only):** CHIAPUZZI, Angelo [IT/IT]; Via Giovanni XXIII, 19, I-20082 Noviglio (IT).
- (74) **Agents:** DE GREGORI, Antonella et al.; Barzano' & Zanardo Milano S.p.A., Via Borgonuovo 10, I-20121 Milano (IT).
- (81) **Designated States (unless otherwise indicated, for every kind of national protection available):** AE, AG, AL, AM,

AO, AT, AU, AZ, BA, BB, BG, BH, BR, BW, BY, BZ, CA, CH, CN, CO, CR, CU, CZ, DE, DK, DM, DO, DZ, EC, EE, EG, ES, FI, GB, GD, GE, GH, GM, GT, HN, HR, HU, ID, IL, IN, IS, JP, KE, KG, KM, KN, KP, KR, KZ, LA, LC, LK, LR, LS, LT, LU, LY, MA, MD, ME, MG, MK, MN, MW, MX, MY, MZ, NA, NG, NI, NO, NZ, OM, PG, PH, PL, PT, RO, RS, RU, SC, SD, SE, SG, SK, SL, SM, ST, SV, SY, TJ, TM, TN, TR, TT, TZ, UA, UG, US, UZ, VC, VN, ZA, ZM, ZW.

(84) **Designated States (unless otherwise indicated, for every kind of regional protection available):** ARIPO (BW, GH, GM, KE, LS, MW, MZ, NA, SD, SL, SZ, TZ, UG, ZM, ZW), Eurasian (AM, AZ, BY, KG, KZ, MD, RU, TJ, TM), European (AT, BE, BG, CH, CY, CZ, DE, DK, EE, ES, FI, FR, GB, GR, HR, HU, IE, IS, IT, LT, LU, LV, MC, MK, MT, NL, NO, PL, PT, RO, SE, SI, SK, TR), OAPI (BF, BJ, CF, CG, CI, CM, GA, GN, GQ, GW, ML, MR, NE, SN, TD, TG).

Published:

- with international search report (Art. 21(3))
- before the expiration of the time limit for amending the claims and to be republished in the event of receipt of amendments (Rule 48.2(h))

(54) **Title:** ELECTRONIC TORQUE WRENCH WITH REPLACEABLE TORQUE SENSORS

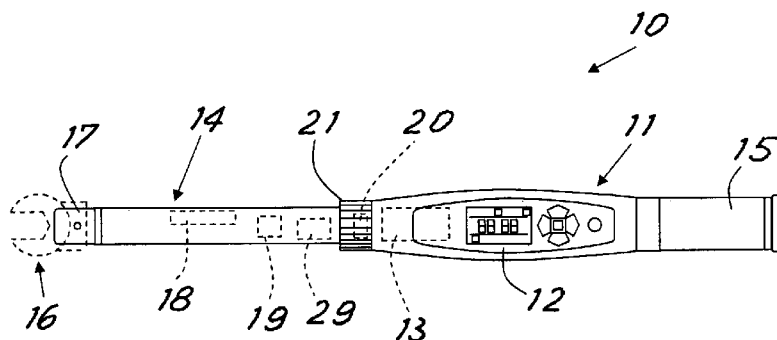

Fig. 1

(57) **Abstract:** An electronic torque wrench (10) comprising a grip body (11) with a user interface (12) and a control electronics (13) for controlling the wrench. From one extremity of the grip body protrudes a mechanical connection element (14) that terminates at one extremity with a tightening head (16). In the connection element are torque sensors (18) for determining the torque transmitted between the grip body and the head and the connection element (14) is connected in a removable and replaceable way to the grip body (11) and comprises memory means (19) containing data for calibrating the wrench to such connection element (14) and means for transferring such data to the control electronics.



WO 2009/115889 A1

"ELECTRONIC TORQUE WRENCH WITH REPLACEABLE TORQUE SENSORS"

The present invention refers to an electronic torque wrench of the type comprising a grip body from which protrudes an extremity terminating with a tightening head.

Generally speaking, such types of wrench are made like a bending-bar transducer having extensometers for measuring the deformation proportionate to the transmitted torque. The extremity of the bar opposite the grip is designed for fitting tools of various shapes suitable for transmitting the torque to screws, bolts, tightening elements, etc. The wrench comprises a user interface with a display unit on which the tightening quantities are shown calculated by internal electronics on the basis of the readings of the torque sensors and of other sensors, e.g., angle sensors.

The transducer is usually conveniently housed in a tubular element, which supports it and at the same time protects the extensometers. Such tubular element is connected integral with the grip body and is an integral part of it, forming a single indissoluble unit envisaged for a determinate measurement range.

In fact, apart from the ergonomic need to differentiate the models according to the maximum wrench torque, to ensure a level of accuracy of the measurements, several models are normally needed, each with a measurement range of its own, which does not generally exceed a 1:5 ratio. For example, a wrench with maximum nominal torque of 250 Nm can operate with sufficient accuracy starting with 50 Nm, a wrench of 100 Nm can start from 20 Nm, and so on.

It follows that to cover an albeit limited range of tightening torques, it could be necessary to have a certain number of torque wrenches, sometimes with a large investment.

Furthermore, in the case of repair or replacement of the torque transducer unit, this operation must necessarily be performed by the manufacturer or by an authorized repair centre and, in any case, the subsequent calibration of the wrench must be done in an adequately equipped metrological laboratory, with time losses sometimes not reconcilable with the user's needs.

The general object of the present invention is to overcome the above-mentioned drawbacks and provide an electronic torque wrench that permits fast adaptability to a broad range of measurement ranges. Furthermore, a further object is to facilitate the repair and cut the tool down times in case of a torque sensor fault.

In view of such object, the idea occurred to make, according to the invention, an electronic torque wrench comprising a grip body having a user interface and a wrench control electronics, from an extremity of the grip body protruding a mechanical connection element terminating at one end with a tightening head, in the connection element being present torque sensors for determining the torque transmitted between the grip body and the head, characterized in that the connection element is connected in a removable and replaceable way to the grip body and comprises memory means containing data for calibrating the wrench with said connection element and means for the transfer of such data to the control electronics.

To more clearly explain the innovative principles of the present invention and its advantages with respect to prior art, a description will be provided below, with the aid of the attached drawings, of a possible exemplary embodiment
5 applying such principles. In the drawings:

- figure 1 represents a schematic view of a torque wrench according to the invention;

- figure 2 represents a schematic view, partial and in section of an area of the wrench of figure 1 disassembled.

10 With reference to the illustrations, the figure 1 shows an electronic torque wrench generically indicated by 10. The wrench comprises a grip body 11 with a user interface 12 and a control electronics of the wrench 13. In the body can also be housed electric power batteries (not shown).

15 The control electronics is of the type known to prior art (e.g., with suitably programmed microprocessor) and will not be further described or shown here. As the expert technician can easily imagine, it will show, for example, on a suitable display of the user interface, various
20 parameters and tightening measurements, according to what is detected by the wrench sensors and operating settings entered by means of commands given by means of the user interface present on the body 11 and/or by means of the remote commands received and transmitted by means of any
25 wireless or wired connection systems.

An element 14 protrudes from an extremity of the grip body which is opposite the extremity 15. The element 14 terminates at an extremity with a tightening head 16 so as to make a mechanical connection between the body 11 and the tightening

head 16. The tightening head 16 can be made removable and replaceable on the connection element, by means of a suitable coupling 17 of the type known to prior art (e.g., a standard square coupling). Advantageously, the connection element is
5 made in the form of a straight tubular element.

In the connection element 14 are present known torque sensors 18 (e.g., extensometer sensors) for detecting the torque transmitted between the grip body 11 and the head 16. The connection element is connected in a removable and
10 replaceable way to the grip body and comprises memory means 19 containing calibrating data of the wrench with such connection element 14. Also provided are means 20 for the transfer of such data to the control electronics of the wrench together with the readings of the torque sensors.
15 Advantageously, the memory means comprise an E²prom memory which can be programmed with the calibration data read during a connection element calibration test. If a subsequent re-calibration is necessary, the operation is thereby made easier by the use of a re-programmable memory.

20 Also advantageously present in the element 14 can be a known angular rotation sensor 29, calibrated together with the torque sensor and this too connected to the control electronics to make known measurements that also require information relating to wrench angular rotation. The memory
25 19 will also contain the calibration data of this angular sensor paired with the torque sensor.

A quick coupling 21 is envisaged between connection element 14 and body 11 to allow the rapid replacement of the connection element.

According to a preferred embodiment of the quick coupling, shown in disassembled condition in figure 2, the connection element is equipped with an axial coupling 22 in a complementary seat 23 on the grip body 11. The axial
5 coupling advantageously comprises ring-nut means 24 for screw or bayonet locking.

In the axial coupling case shown, also advantageously present is a locator 27 of reference of the angular position between grip body and connection element. Advantageously,
10 such locator consists of a pin 27 protruding parallel to the coupling axis of the element 14 which fits into a specific seat 28 in the body 11 (or vice versa).

Advantageously, the axial coupling also comprises inside electric contacts 25, 26 for connecting the sensors 18 and
15 some memory means 19 to the control electronics in the grip body. The contacts are preferably of the front coupling type, so the axial coupling of the mechanical connection element 14 on the grip body also automatically makes the power connection.

20 The assembly only calls for the introduction of the section 22 (e.g., cylindrical or precision) in the seat 23 and the tightening of the ring nut 24 on the specific extremity of the wrench body. Thanks to the presence on the pipe of a stop collar 30 which interacts on the bottom of the ring
25 nut 24, the solid mechanical union is obtained of the connection element 14, that forms the transducer unit, with the wrench body and a contemporaneous multi-contact electrical connection between the two parts.

As the technician can easily imagine on the basis of the

description given here, connection means can also be used without electric contact, e.g., by means of transponder.

In the event of heads 16 being used with inserts having known electronic systems of identification by the wrench, the corresponding identification signals can also be transferred from element 14 to the wrench.

If so desired, other sensors can be fitted in the connection element and the memory means can include suitable calibration data for such sensors as well. If necessary, angle sensors can also be fitted in the grip.

In any case, the calibration operation can be performed *a priori* by the manufacturer in the same physical and geometric conditions they are in when the mechanical connection element 14 is fitted on the grip body having its own electronics.

This way, the electronics of the wrench body receives (e.g., at start-up) the required information and the operating parameters for the immediate use of the fitted transducer unit, without any further calibrations having to be made.

At this point, it is clear how the preset objects have been achieved.

Thanks to the principles of the invention, the wrench can be fitted with a plurality of interchangeable connection elements 14 (only one of which is shown for the sake of simplicity in the illustrations), each with different length and/or measurement sensors suitable for a different torque interval or for different types of measurement. The calibration data of each element are already contained in

the internal memory means of the element, so that all the operator has to do is disengage a connection element and replace it with another selected one to obtain a wrench suitable for a new tightening torque interval.

5 Even in the case of a fault affecting the torque sensors, all the operator has to do is replace the connection element with another, already pre-calibrated, without any need for a tool stop for the calibration. The operator must also keep, easily and at limited cost, spare connection elements 14,
10 so as to be able to quickly overcome any malfunction of the sensors.

The operator will not need to perform calibrations on the torque transducer, an operation that generally requires adequate equipment and specific know-how. Even in the case
15 of the presence of a gyroscope, with the prior art wrenches a generally complicated calibration operation would be needed, but with the wrench described here such operation is no longer necessary.

Because the tubular element that contains the transducer
20 and other measurement systems can be calibrated separately, it follows that the wrenches can be assembled definitively according to the requirement: consequently the stock of finished wrenches in store can be considerably reduced because the two units can be kept separate and only
25 assembled at the time of dispatch. If necessary, the wrench could be sent disassembled and then assembled by the user before use.

Naturally, the above description of an embodiment applying the innovative principles of the present invention is shown

by way of example of such innovative principles only and should not therefore be taken as limitative of the patent right ambit claimed here.

1. Electronic torque wrench (10) comprising a grip body (11) having a user interface (12) and a control electronics (13) for controlling the wrench, from one extremity of the grip body protruding a mechanical connection element (14) terminating at one extremity with a tightening head (16), in the connection element being present torque sensors (18) for determining the torque transmitted between the grip body and the head, characterized in that the connection element (14) is connected in a removable and replaceable way to the grip body (11) and comprises memory means (19) that contain data for calibrating the wrench to such connection element (14) and means for transferring such data to the control electronics.

2. Wrench according to claim 1, characterized in that for the removable and replaceable connection, between the connection element and the grip body an axial coupling (21) is present.

3. Wrench according to claim 1, characterized in that the axial coupling has ring nut means (24) for screw or bayonet locking.

4. Wrench according to claim 2, characterized in that the axial coupling (21) comprises electric contacts (25, 26) for connecting the sensors and the memory means to the control electronics in the grip body.

5. Wrench according to claim 2, characterized in that the axial coupling comprises a locator (27, 28) of reference of the angular position between grip body and connection

element.

6. Wrench according to claim 1, characterized in that the tightening head (16) can be coupled in a removable and replaceable way on the connection element (14).

5 7. Wrench according to claim 1, characterized in that the connection element (14) is made in the shape of a straight tubular element.

8. Wrench according to claim 1, characterized in that in the connection element (14) an angular rotation sensor (29)
10 is also present.

9. Wrench according to claim 1, characterized in that the memory means (19) comprise an E²prom memory.

10. Wrench according to claim 1, characterized in that it comprises a plurality of interchangeable connection elements
15 (14), each of different length and/or measurement sensors suitable for a different torque interval.

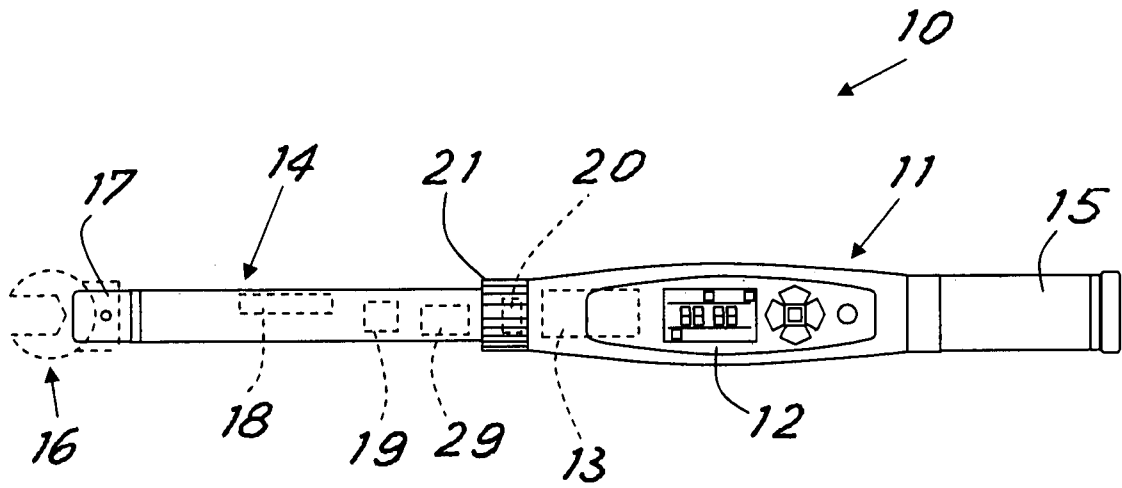

Fig. 1

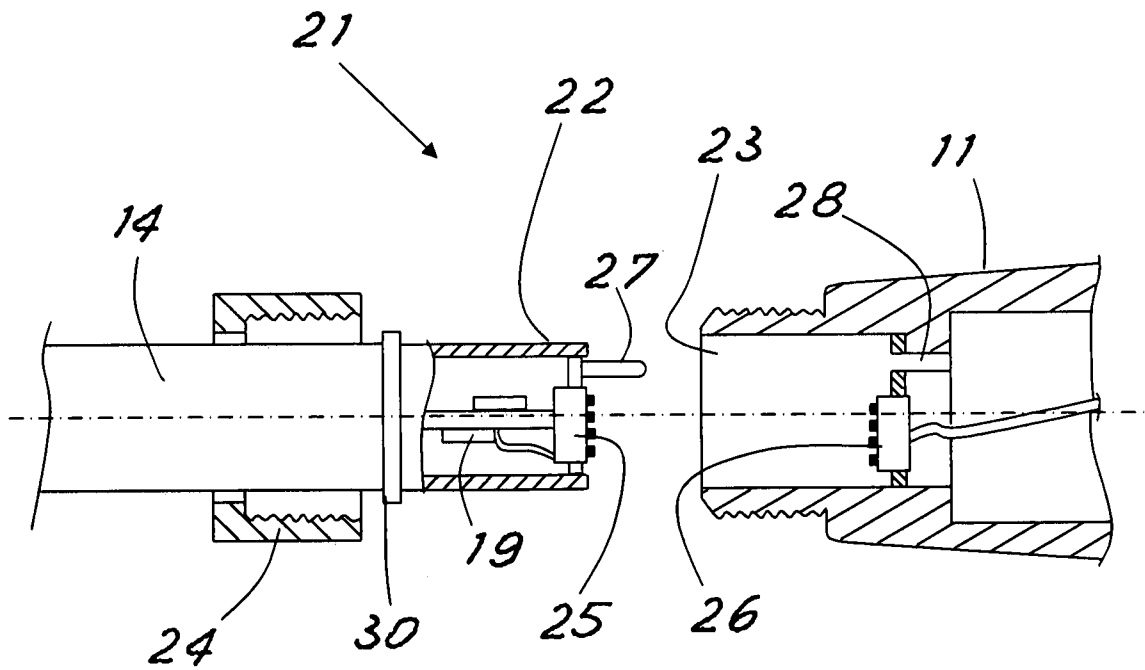

Fig. 2

INTERNATIONAL SEARCH REPORT

International application No
PCT/IB2009/000527

A. CLASSIFICATION OF SUBJECT MATTER INV. B25B23/142		
According to International Patent Classification (IPC) or to both national classification and IPC		
B. FIELDS SEARCHED		
Minimum documentation searched (classification system followed by classification symbols) B25B		
Documentation searched other than minimum documentation to the extent that such documents are included in the fields searched		
Electronic data base consulted during the international search (name of data base and, where practical, search terms used) EPO-Internal		
C. DOCUMENTS CONSIDERED TO BE RELEVANT		
Category*	Citation of document, with indication, where appropriate, of the relevant passages	Relevant to claim No.
Y	EP 1 060 844 A (BLM S A S DI L BAREGGI & C [IT] ATLAS COPCO BLM S R L [IT]) 20 December 2000 (2000-12-20) paragraphs [0015] - [0025] figures 1,2,5	1-10
Y	DE 10 2005 039682 A1 (STAND TOOLS ENTPR CO LTD TAICH [TW]) 30 March 2006 (2006-03-30) paragraphs [0018] - [0021] paragraphs [0025] - [0027] figures 1-5	1-10
Y	DE 20 2004 017472 U1 (HAZET WERK ZERVER HERMANN [DE]) 5 January 2005 (2005-01-05) paragraphs [0032] - [0036] figure 1	8
	----- -/--	
<input checked="" type="checkbox"/> Further documents are listed in the continuation of Box C. <input checked="" type="checkbox"/> See patent family annex.		
* Special categories of cited documents :		
A document defining the general state of the art which is not considered to be of particular relevance *E* earlier document but published on or after the international filing date *L* document which may throw doubts on priority claim(s) or which is cited to establish the publication date of another citation or other special reason (as specified) *O* document referring to an oral disclosure, use, exhibition or other means *P* document published prior to the international filing date but later than the priority date claimed		*T* later document published after the international filing date or priority date and not in conflict with the application but cited to understand the principle or theory underlying the invention *X* document of particular relevance; the claimed invention cannot be considered novel or cannot be considered to involve an inventive step when the document is taken alone *Y* document of particular relevance; the claimed invention cannot be considered to involve an inventive step when the document is combined with one or more other such documents, such combination being obvious to a person skilled in the art. *&* document member of the same patent family
Date of the actual completion of the international search <p style="text-align: center;">3 July 2009</p>		Date of mailing of the international search report <p style="text-align: center;">10/07/2009</p>
Name and mailing address of the ISA/ European Patent Office, P.B. 5818 Patentlaan 2 NL - 2280 HV Rijswijk Tel. (+31-70) 340-2040, Fax: (+31-70) 340-3016		Authorized officer <p style="text-align: center;">Schultz, Tom</p>

INTERNATIONAL SEARCH REPORT

International application No
PCT/IB2009/000527

C(Continuation). DOCUMENTS CONSIDERED TO BE RELEVANT		
Category*	Citation of document, with indication, where appropriate, of the relevant passages	Relevant to claim No.
Y	US 2007/119267 A1 (ANJANAPPA MUNISWAMAPPA [US] ET AL ANJANAPPA MUNISWAMAPPA [US] ET AL) 31 May 2007 (2007-05-31) paragraphs [0006], [0007], [0009], [0021] - [0023], [0026] - [0028], [0031] figures 1,2a,2b,2c,3,4 -----	10
A	DE 42 43 317 A1 (HINUEBER, EDGAR VON, DIPL.-ING., 6602 DUDWEILER, DE) 9 June 1993 (1993-06-09) column 1, line 52 - column 2, line 19 figure 1 -----	8
A	WO 00/45997 A (WILHELM RAIMUND [DE]) 10 August 2000 (2000-08-10) page 6, line 26 - page 8, line 9 figure 1 -----	1

INTERNATIONAL SEARCH REPORT

Information on patent family members

International application No

PCT/IB2009/000527

Patent document cited in search report	Publication date	Patent family member(s)	Publication date	
EP 1060844	A	20-12-2000	DE 60032194 T2 IT MI991341 A1 US 6234051 B1	20-09-2007 18-12-2000 22-05-2001
DE 102005039682	A1	30-03-2006	TW 276516 B	21-03-2007
DE 202004017472	U1	05-01-2005	NONE	
US 2007119267	A1	31-05-2007	NONE	
DE 4243317	A1	09-06-1993	NONE	
WO 0045997	A	10-08-2000	AU 2668600 A DE 19904773 C1	25-08-2000 28-09-2000