

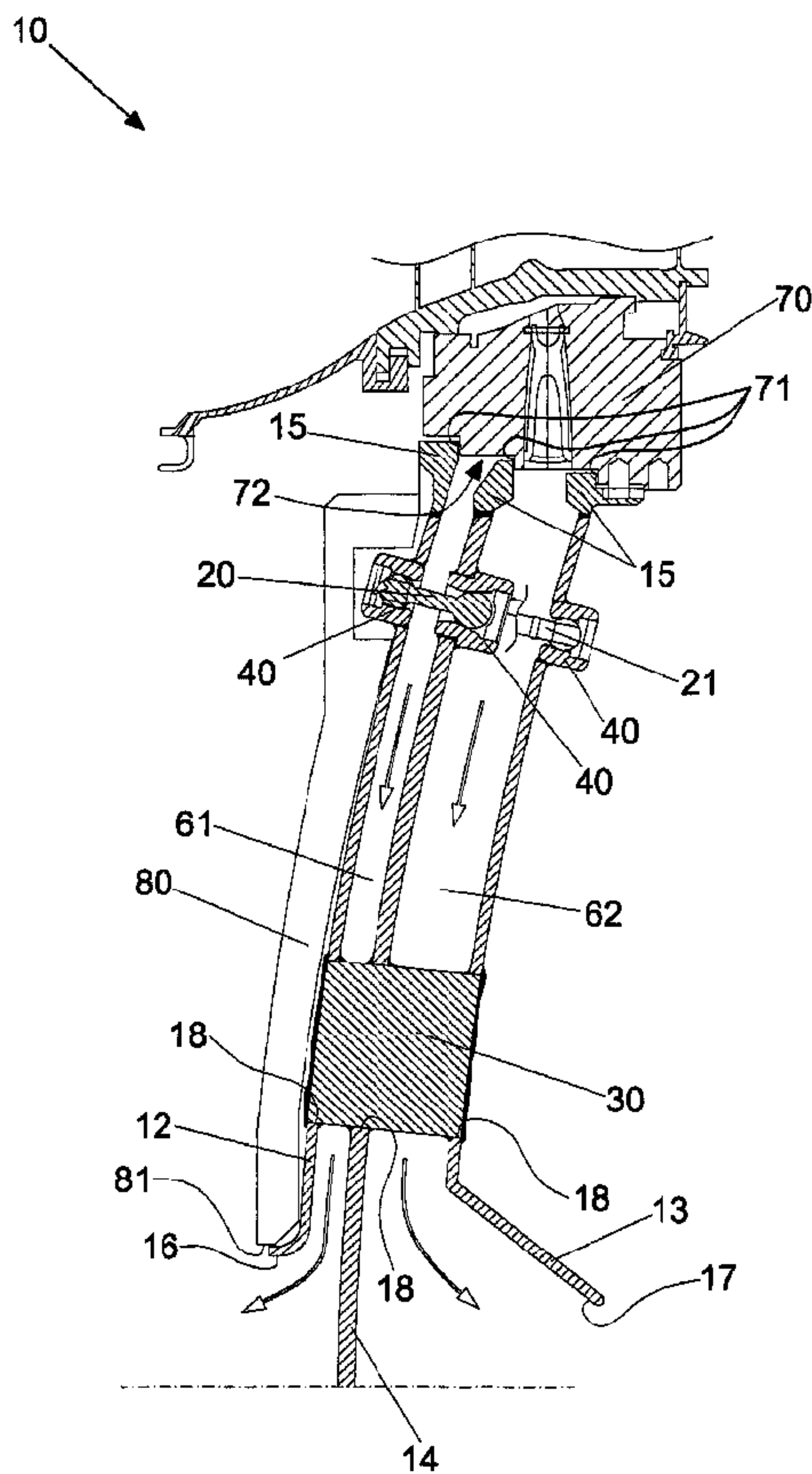

(86) Date de dépôt PCT/PCT Filing Date: 2005/09/14
 (87) Date publication PCT/PCT Publication Date: 2006/03/23
 (45) Date de délivrance/Issue Date: 2014/04/15
 (85) Entrée phase nationale/National Entry: 2007/03/15
 (86) N° demande PCT/PCT Application No.: EP 2005/009996
 (87) N° publication PCT/PCT Publication No.: 2006/029888
 (30) Priorité/Priority: 2004/09/17 (IT MI2004A001778)

(51) Cl.Int./Int.Cl. *F01D 11/00* (2006.01),
F02C 3/10 (2006.01), *F02C 7/28* (2006.01)
 (72) Inventeurs/Inventors:
PECCHIOLI, MARIO, IT;
BIANCHI, DINO, IT
 (73) Propriétaire/Owner:
NUOVO PIGNONE S.P.A., IT
 (74) Agent: CRAIG WILSON AND COMPANY

(54) Titre : STRUCTURE SERVANT A SEPARER LES ZONES INTERIEURES D'UNE TURBINE HAUTE PRESSION ET BASSE PRESSION
 (54) Title: STRUCTURE FOR SEPARATING THE INTERNAL AREAS OF A HIGH PRESSURE AND A LOW PRESSURE TURBINE



(57) Abrégé/Abstract:

Convex sealing bottom (10) for a twin-shaft turbine of the type comprising a series of convex disks constrained to each other by means of a series of pins, each disk of said disks comprises an outer shaped edge which is engaged with a corresponding annular

(57) **Abrégé(suite)/Abstract(continued):**

surface (71) of an inner grooved surface (72) of a ring (70) for obtaining an axial seal. The series of disks comprises three disks, a first disk (12), a second disk (13) and a third disk (14) respectively. The three disks are fixed to each other centrally by means of a series of spokes (30) and are constrained in pairs respectively by means of a series of pins which are arranged orthogonally to the three disks to minimize the relative movements of the three disks in an axial direction at the same time allowing the radial dilatations of the three disks themselves.

(12) INTERNATIONAL APPLICATION PUBLISHED UNDER THE PATENT COOPERATION TREATY (PCT)

(19) World Intellectual Property Organization
International Bureau(43) International Publication Date
23 March 2006 (23.03.2006)

PCT

(10) International Publication Number
WO 2006/029888 A1

(51) International Patent Classification:

F01D 11/00 (2006.01) *F02C 7/28* (2006.01)
F02C 3/10 (2006.01)

(21) International Application Number:

PCT/EP2005/009996

(22) International Filing Date:

14 September 2005 (14.09.2005)

(25) Filing Language:

English

(26) Publication Language:

English

(30) Priority Data:

MI2004A001778

17 September 2004 (17.09.2004) IT

(71) Applicant (for all designated States except US): **NUOVO PIGNONE S.P.A.** [IT/IT]; Via F. Matteucci, 2, I-50127 Firenze (IT).

(72) Inventors; and

(75) Inventors/Applicants (for US only): **PECCHIOLI, Mario** [IT/IT]; Via Calamai, 5, I-59100 Prato (IT).**BIANCHI, Dino** [IT/IT]; Via Coppo di Marcovaldo, 22, I-50143 Firenze (IT).(74) Agents: **DE GREGORI, Antonella** et al.; Ing. Barzanò & Zanardo Milano S.p.A., Via Borgonuovo, 10, I-20121 Milano (IT).

(81) Designated States (unless otherwise indicated, for every kind of national protection available): AE, AG, AL, AM, AT, AU, AZ, BA, BB, BG, BR, BW, BY, BZ, CA, CH, CN, CO, CR, CU, CZ, DE, DK, DM, DZ, EC, EE, EG, ES, FI, GB, GD, GE, GH, GM, HR, HU, ID, IL, IN, IS, JP, KE, KG, KM, KP, KR, KZ, LC, LK, LR, LS, LT, LU, LV, MA, MD, MG, MK, MN, MW, MX, MZ, NA, NG, NI, NO, NZ, OM, PG, PH, PL, PT, RO, RU, SC, SD, SE, SG, SK, SL, SM, SY, TJ, TM, TN, TR, TT, TZ, UA, UG, US, UZ, VC, VN, YU, ZA, ZM, ZW.

(84) Designated States (unless otherwise indicated, for every kind of regional protection available): ARIPO (BW, GH, GM, KE, LS, MW, MZ, NA, SD, SL, SZ, TZ, UG, ZM, ZW), Eurasian (AM, AZ, BY, KG, KZ, MD, RU, TJ, TM), European (AT, BE, BG, CH, CY, CZ, DE, DK, EE, ES, FI,

[Continued on next page]

(54) Title: STRUCTURE FOR SEPARATING THE INTERNAL AREAS OF A HIGH PRESSURE AND A LOW PRESSURE TURBINE

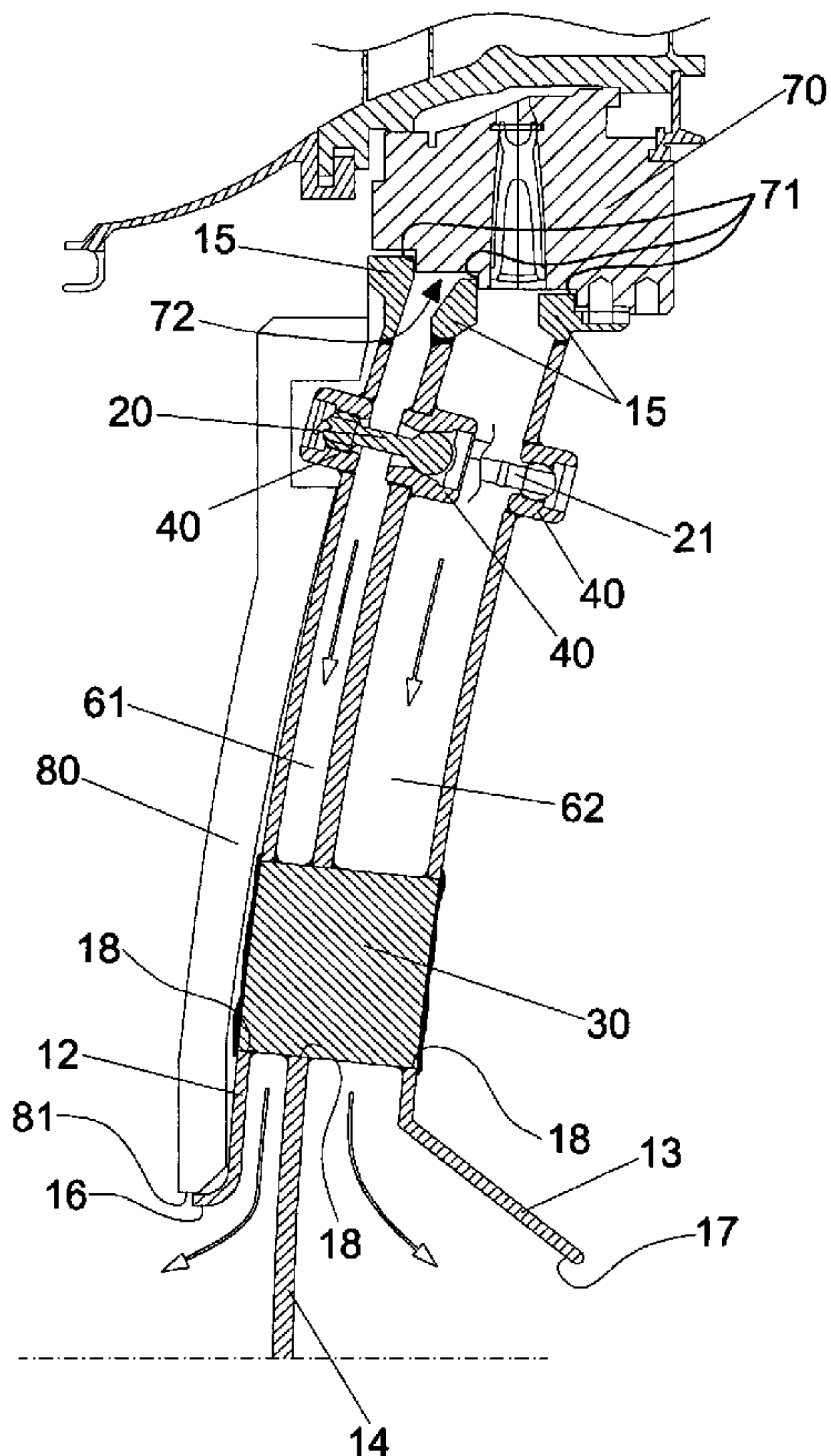

(57) Abstract: Convex sealing bottom (10) for a twin-shaft turbine of the type comprising a series of convex disks constrained to each other by means of a series of pins, each disk of said disks comprises an outer shaped edge which is engaged with a corresponding annular surface (71) of an inner grooved surface (72) of a ring (70) for obtaining an axial seal. The series of disks comprises three disks, a first disk (12), a second disk (13) and a third disk (14) respectively. The three disks are fixed to each other centrally by means of a series of spokes (30) and are constrained in pairs respectively by means of a series of pins which are arranged orthogonally to the three disks to minimize the relative movements of the three disks in an axial direction at the same time allowing the radial dilatations of the three disks themselves.

WO 2006/029888 A1

WO 2006/029888 A1



FR, GB, GR, HU, IE, IS, IT, LT, LU, LV, MC, NL, PL, PT,
RO, SE, SI, SK, TR), OAPI (BF, BJ, CF, CG, CI, CM, GA,
GN, GQ, GW, ML, MR, NE, SN, TD, TG).

— *before the expiration of the time limit for amending the
claims and to be republished in the event of receipt of
amendments*

Published:

— *with international search report*

*For two-letter codes and other abbreviations, refer to the "Guid-
ance Notes on Codes and Abbreviations" appearing at the begin-
ning of each regular issue of the PCT Gazette.*

5

STRUCTURE FOR SEPARATING THE INTERNAL AREAS OF A HIGH PRESSURE AND A LOW PRESSURE TURBINE

The present invention relates to a convex sealing bottom for a twin-shaft gas turbine.

10 A gas turbine is a rotating thermal machine which converts the enthalpy of a gas into useful work, using gases coming from a combustion and which supplies mechanical power on a rotating shaft.

The turbine therefore normally comprises a compressor or turbo-compressor, inside which the air taken from
15 the outside is brought under pressure.

Various injectors feed the fuel which is mixed with the air to form a air-fuel ignition mixture.

The axial compressor is entrained by a so-called
20 turbine, or turbo-expander, which supplies mechanical energy to a user transforming the enthalpy of the gases combusted in the combustion chamber.

In applications for the generation of mechanical energy, the expansion jump is subdivided into two partial
25 jumps, each of which takes place inside a turbine. The

high-pressure turbine, downstream of the combustion chamber, entrains the compression. The low-pressure turbine, which collects the gases coming from the high-pressure turbine, is then connected to a user.

5 The turbo-expander, turbo-compressor, combustion chamber (or heater), outlet shaft, regulation system and ignition system, form the essential parts of a gas turbine plant.

As far as the functioning of a gas turbine is concerned, it is known that the fluid penetrates the compressor through a series of inlet ducts.

In these canalizations, the gas has low-pressure and low-temperature characteristics, whereas, as it passes through the compressor, the gas is compressed and its temperature increases.

It then penetrates into the combustion (or heating) chamber, where it undergoes a further significant increase in temperature.

The heat necessary for the temperature increase of the gas is supplied by the combustion of gas fuel introduced into the heating chamber, by means of injectors.

The triggering of the combustion, when the machine is activated, is obtained by means of sparking plugs.

At the outlet of the combustion chamber, the high-pressure and high-temperature gas reaches the turbine,

through specific ducts, where it gives up part of the energy accumulated in the compressor and heating chamber (combustor) and then flows outside by means of the discharge channels.

5 In applications for the generation of mechanical energy, the internal area of the high pressure turbine and the internal area of the low pressure turbine are separated by means of a bottom whose function is to guarantee a sealing between each other.

10 This is to avoid the drawing of gases which would jeopardize the reliability and performances of the power turbine.

 The bottom also acts as a duct for a flow of so-called "purge" air, i.e. a flow of pressurized air which
15 prevents the ingestion of hot gases through the duct towards the bottom and towards the components of the turbine which would be damaged by these hot gases.

 The convex bottom currently comprises two convex disks constrained to each other by means of a series of
20 pins.

 These disks have an outer shaped edge which are coupled, forming a seal, of the metal on metal type, with a sealing ring.

 Furthermore, said two disks define a channel for the
25 purge air towards the low pressure turbine.

One of the disadvantages of the bottoms of known turbines is that, as a result of thermal gradients, they undergo deformations which cause seal losses in the areas where the seal is obtained by means of specific geometries.

The reason for this is that when the turbine is running, the pins, initially axially oriented, rotate specifically as a result of non-uniform thermal deformations on the disks, jeopardizing the correct seal on the sealing ring.

A further disadvantage is that, in this way, there is the ingestion of hot gases which jeopardize the useful life of the bottom and other components of the gas turbine.

This is because oxidation phenomena are created at hot temperatures which, accompanied by fatigue phenomena, intensify the stress causing, with time, cracks and splitting, finally jeopardizing the correct functioning of the bottom and other components.

An objective of the present invention is to provide a bottom for a twin-shaft turbine which maintains a seal without causing mechanical stress on the bottom itself.

A further objective is to provide a convex sealing bottom for a twin-shaft turbine which allows an increase in the performances of the turbine itself, maintaining a

157207 72NP

high useful life of the bottom itself.

Yet another objective is to provide a convex sealing bottom for a twin-shaft turbine which avoids the ingestion of hot gases coming both from a low pressure turbine and a high pressure turbine.

An additional objective is to provide a convex sealing bottom for a twin-shaft turbine which is simple and economical.

These objections according to the present invention are achieved by providing a convex sealing bottom for a twin-shaft turbine of the type including a series of convex disks, constrained to each other by means of a series of pins. Each disk of said disks may include an outer shaped edge which is engaged with a corresponding annular surface of an inner grooved surface of a ring for obtaining an axial seal, characterized in that said series of disks are three disks, a first disk (12), a second disk and a third disk respectively, and in that said three disks are fixed to each other centrally by means of a series of spokes and in that they are constrained in pairs respectively by means of said series of pins which are arranged orthogonally to said three disks to minimize the relative movements of said three disks in an axial direction at the same time allowing the radial dilatations of said three disks.

Each disk of said three disks may include a series of housings for said series of pins.

The series of housings may be situated on each disk

157207 72NP

of said three disks along a circumference close to the outer circular shaped edge.

The housings may be bushings welded to each disk which are distributed at an equidistance along a circumference arranged on a base surface of each disk.

The first disk may have a central opening and said second disk may correspondingly have a central opening.

The third disk may be situated between said first disk and said second disk and with these defines a first duct and a second duct respectively for respective two streams of pressurized air fed from outside the machine towards a high pressure turbine and towards a low pressure turbine respectively.

Each disk of said three disks may include a series of pass-through cuts situated on a base surface and arranged radially, equidistant and uniformly distributed along a circumference of said base surface.

Said bottom may include a series of spokes inserted in a corresponding series of cuts of each disk of said three disks and welded to said three disks in corresponding central portions of each of these.

The bottom may include a first series of pins and a second series of pins with a round head. Said first series of pins constrains said first disk to said third disk (14), whereas said second series of pins constrains said second disk to said third disk.

The pins of said first series of pins and said second series of pins may be distributed at an

157207 72NP

equidistance on a base circumference of each disk of said three disks.

The pins of said first series of pins may be angularly dephased with respect to said second series of pins preferably by an angle of 15° .

Said first series of pins and said second series of pins may each include twelve round-headed pins.

Said first disk and said second disk may each include twelve bushings respectively as housings for the first series of pins and for the second series of pins and in that said third disk may include twenty-four bushings respectively as housings for said first series of pins and for said second series of pins.

The bottom may include an insulating element applied to said first disk.

The characteristics and advantages of a convex sealing bottom for a twin-shaft gas turbine according to the present invention will appear more evident from the following illustrative and non-limiting description, referring to the schematic drawings enclosed, in which:

figure 1 is a raised sectional side view of a preferred embodiment of a bottom of a twin-shaft turbine according to the present invention;

figure 2 is an exploded raised perspective right side view of the bottom of figure 1.

With reference to the figures, these show a convex sealing bottom 10 for a twin-shaft turbine having a high

pressure turbine and a low pressure turbine, said bottom
10 comprises a series of disks, in particular three con-
vex disks constrained to and distanced from each other by
means of a series of pins arranged in series orthogonally
5 to a base surface of each disks of said three disks.

Each pin of said series of pins respectively con-
strains two disks of said series of disks and is arranged
orthogonally to these so as to prevent their relative
movements in an axial direction, i.e. in a direction par-
10 allel to the axis of the gas turbine, during the func-
tioning of the gas turbine.

In other words, each pin is orthogonal to a base
surface of each of the two disks in which it is inserted,
so as to prevent or in any case minimize the relative
15 movements between the two disks in an axial direction,
thus maintaining a seal with a nozzle-holder ring 70.

At the same time, each pin allows the disks to which
it is constrained, to move in a radial direction so that
the disks can freely adapt themselves to the thermal de-
20 formations without generating stress on the disks them-
selves.

This is possible as each pin, in the area in which
it is constrained, is orthogonal to a base surface of
each disk to which it is constrained, in particular it is
25 orthogonal to a portion of the base surface around which

it is constrained to the disks.

The reason for this is to avoid possible states of stress on the disks themselves which could jeopardize the correct functioning and useful life of the convex bottom
5 10.

Said series of disks are three convex disks and are respectively a first disk 12, a second disk 13 and a third disk 14.

Said three disks are arranged along the axis of the
10 machine and have an outer circular shaped edge 15 which is engaged to obtain the axial seal, of the metal-on-metal type, on a corresponding annular surface 71 of an inner grooved surface 72 of said ring 70 coaxial with the axis of the turbine.

15 Each annular surface 71 is also orthogonal to the axis of the turbine.

Each disk of said three disks preferably comprises a series of housings 40 for said series of pins 20 and 21.

Said housings 40 are situated on each disk close to
20 the outer circular shaped edge 15.

Said housings 40 are preferably bushings welded or brazed to each disk which are distributed at an equidistance along a circumference arranged on a base surface of each disk.

25 Said first disk 12 has a central opening 16 and said

second disk 13 correspondingly has a central opening 17.

Said third disk 14 is situated between said first disk 12 and said second disk 13 and together with these, defines a first channel 61 and a second channel 62, re-
5 spectively.

Said first channel 61 and said second channel 62 have the function of bringing air under pressure (purge air) downstream of the high pressure turbine and upstream of the low pressure turbine respectively, avoiding the
10 ingestion of hot gases which could damage the components of the turbine.

Said bottom 10 comprises a series of spokes 30 welded to said three disks in corresponding central portions of each of these.

15 Each disk of said three disks comprises a series of pass-through cuts 18 situated on a base surface and arranged radially, equidistant and uniformly distributed along a circumference of said base surface.

Said series of spokes 30 are inserted in the corresponding series of cuts 18 of each disk of said three
20 disks and made integral preferably by means of welding or brazing.

Said series of pins comprises a first series of pins
20 and a second series of pins 21, said first series of
25 pins 20 constrains said first disk 12 to said third disk

14, whereas said second series of pins 21 constrains said second disk 13 to said third disk 14.

Furthermore, said first series of pins 20 is preferably angularly dephased with respect to second series
5 of pins 21 by an angle preferably of 15°.

Said first series of pins 20 and said second series of pins 21 each preferably comprise twelve round-headed pins.

The first disk 12 and the second disk 13 consequently, each comprise 12 welded or brazed bushings, as
10 housings for the first series of pins 20 and for the second series of pins 21, respectively.

The third disk 14 consequently comprises 24 welded or brazed bushings as housings for the first series of
15 pins 20 and for the second series of pins 21, respectively.

By means of a series of round-headed pins arranged orthogonally to said disks, it is advantageously possible to allow the disks themselves to radially dilate without
20 generating stress.

Said bottom 10, moreover, comprises an insulating element 80 applied on the first disk 12.

Said insulating element has a disk form having a central hole 81 for the passage of a stream of air fed
25 through the opening 16.

By means of a bottom for a twin-shaft turbine according to the present invention, it is advantageously possible to have two ducts or channels for respective two streams of pressurized air (purge air), each of which is
5 fed from outside the machine towards the low pressure turbine and towards the high pressure turbine respectively.

In this way, it is advantageously possible to avoid the ingestion of hot gases also coming from the high
10 pressure turbine protecting the life of the components of the turbine and its reliability.

It can thus be seen that a convex sealing bottom for a twin-shaft turbine according to the present invention achieves the purposes specified above.

15 The convex sealing bottom for a twin-shaft turbine of the present invention thus conceived can undergo numerous modifications and variants, all included in the same inventive concept.

Furthermore, in practice, the materials used, as
20 also the dimensions and components, can vary according to technical demands.

157207 72NP

WHAT IS CLAIMED IS:

1. A convex sealing bottom for a twin-shaft turbine comprising:

a series of convex disks, constrained to each other by means of a series of pins, each disk of said series of disks comprises an outer shaped edge which is engaged with a corresponding annular surface of an inner grooved surface of a ring for obtaining an axial seal, wherein said series of disks comprise three disks, a first disk, a second disk and a third disk respectively, wherein said three disks are fixed to each other centrally by means of a series of spokes, the three disks being constrained in pairs respectively by means of said series of pins which are arranged orthogonally to said three disks to minimize the relative movements of said three disks in an axial direction at the same time allowing the radial dilatations of said three disks;

wherein the series of pins comprise a first series of pins and a second series of pins with a round head, said first series of pins constrains said first disk to said third disk, whereas said second series of pins constrains said second disk to said third disk.

2. The convex sealing bottom according to claim 1, wherein each disk of said three disks comprises a series of housings for said series of pins.

3. The convex sealing bottom according to claim 1 or 2, wherein said series of housings is situated on

157207 72NP

each disk of said three disks along a circumference close to the outer circular shaped edge.

4. The convex sealing bottom according to claim 2, wherein said series of housings are bushings welded to each disk which are distributed at an equidistance along a circumference arranged on a base surface of each disk.

5. The convex sealing bottom according to claim 1, wherein said first disk has a central opening and said second disk correspondingly has a central opening.

6. The convex sealing bottom according to claim 1, wherein said third disk is situated between said first disk and said second disk and with these defines a first duct and a second duct respectively for respective two streams of pressurized air fed from outside the machine towards a high pressure turbine and towards a low pressure turbine respectively.

7. The convex sealing bottom according to claim 1, wherein each disk of said three disks comprises a series of pass-through cuts situated on a base surface and arranged radially, equidistant and uniformly distributed along a circumference of said base surface.

8. The convex sealing bottom according to claim 1, wherein said convex sealing bottom comprises the series of spokes inserted in a corresponding series of cuts of each disk of said three disks and welded to said

157207 72NP

three disks in corresponding central portions of each of these.

9. The convex sealing bottom according to claim 1, wherein the pins of said first series of pins and said second series of pins are distributed at an equidistance on a base circumference of each disk of said three disks.

10. The convex sealing bottom according to claim 9, wherein the pins of said first series of pins are angularly dephased with respect to said second series of pins by an angle of approximately 15° .

11. The convex sealing bottom according to claim 9, wherein said first series of pins and said second series of pins each comprise twelve round-headed pins.

12. The convex sealing bottom according to claim 9, wherein said first disk and said second disk each comprise twelve bushings respectively as housings for the first series of pins and for the second series of pins and in that said third disk comprises twenty-four bushings respectively as housings for said first series of pins and for said second series of pins.

13. The convex sealing bottom according to claim 1, further comprises an insulating element applied to said first disk.

1/2

10

Fig. 1

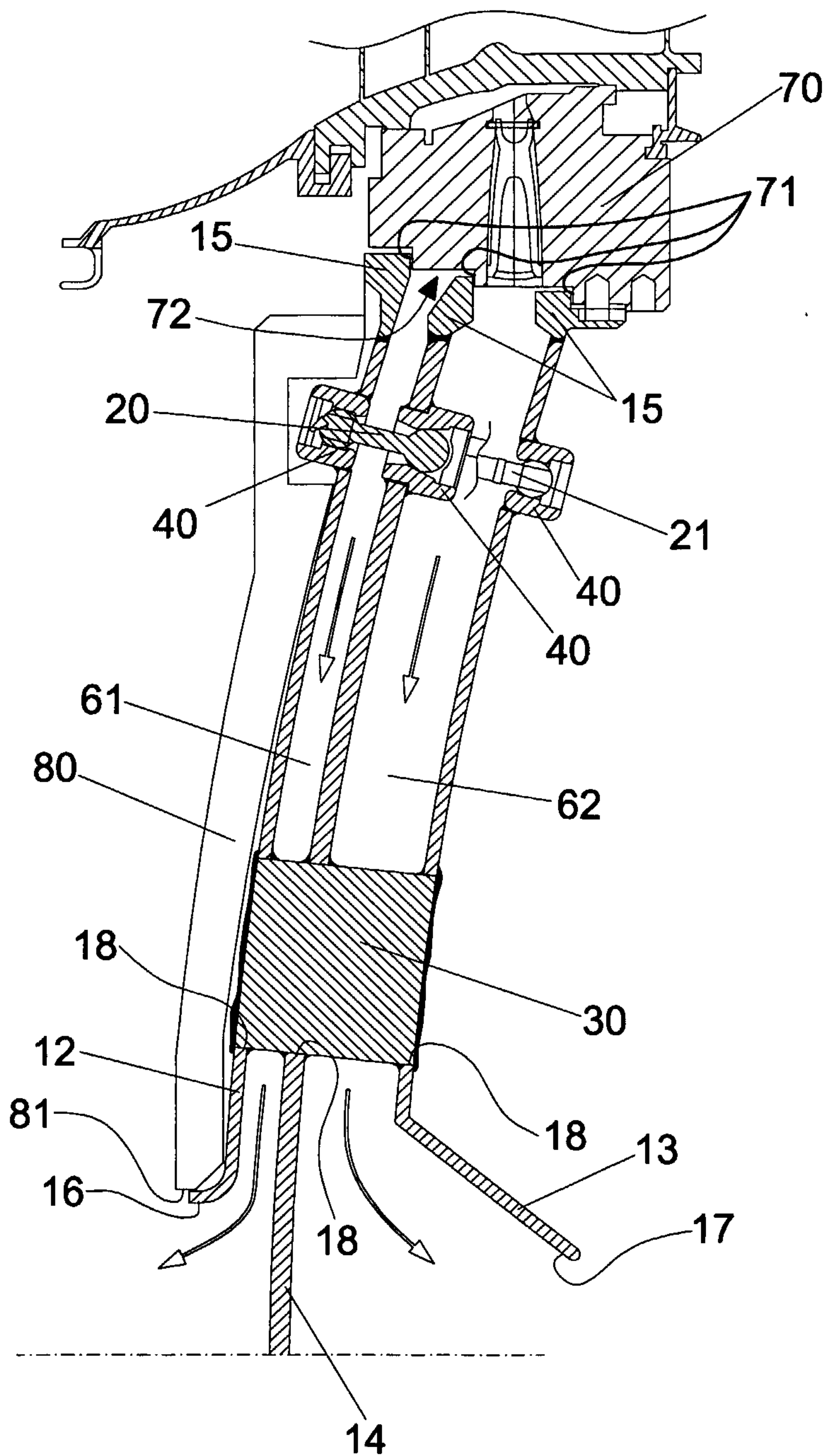

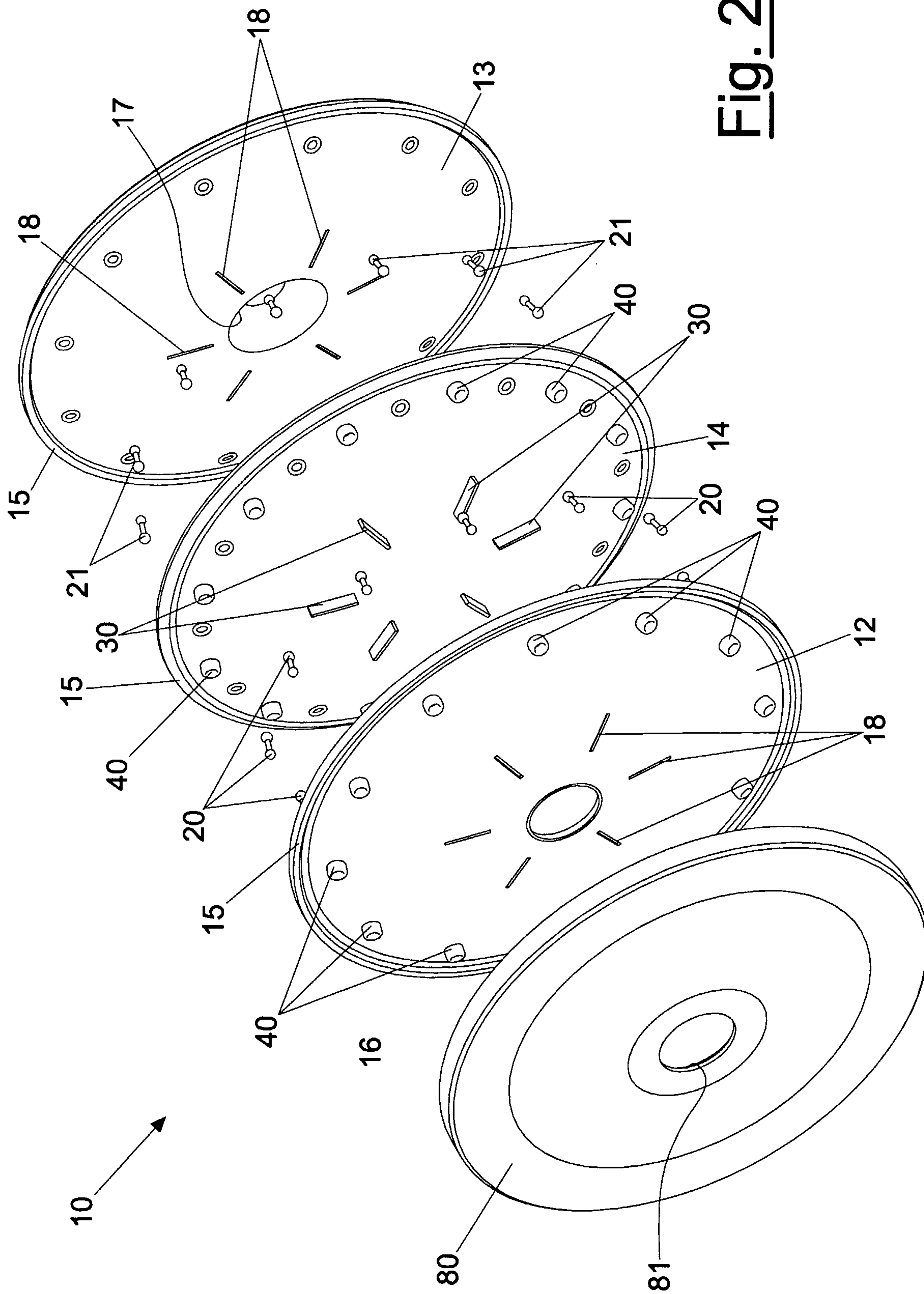

Fig. 2

10

