

Jan. 6, 1942.

A. A. HEEREN
CEILING CONSTRUCTION
Filed July 15, 1939

2,268,822

Fig. 1

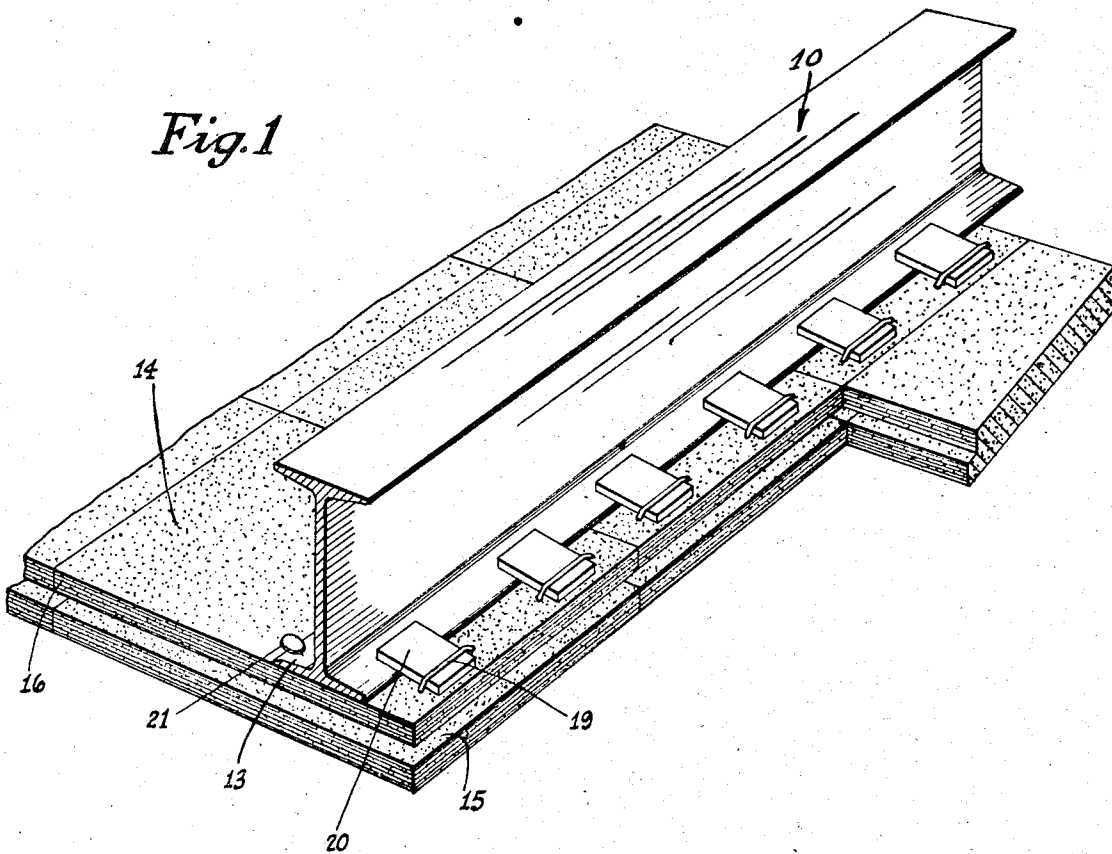

Fig. 2

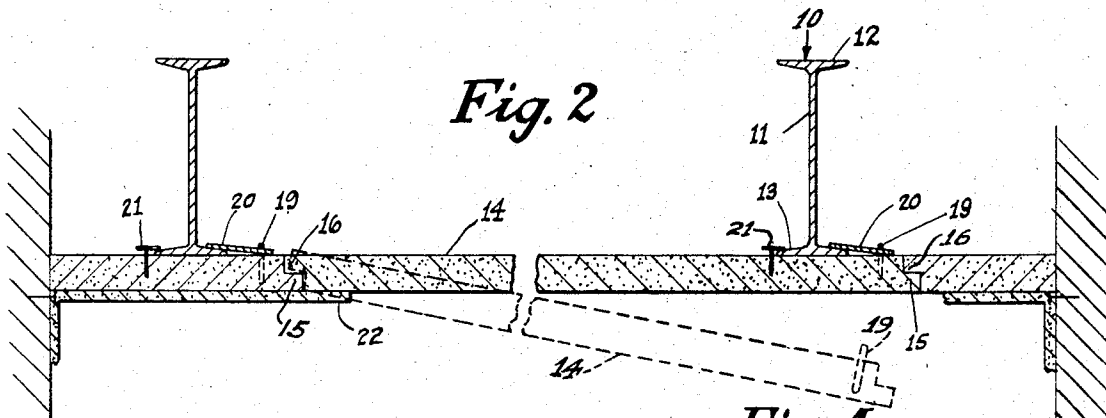

Fig. 4

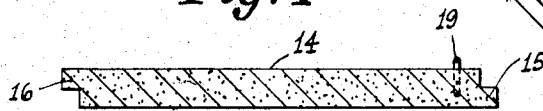
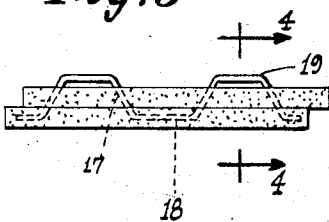

Fig. 3



INVENTOR
ARTHUR A. HEEREN

BY *L. A. Paley*
ATTORNEY

UNITED STATES PATENT OFFICE

2,268,822

CEILING CONSTRUCTION

Arthur A. Heeren, Chicago, Ill., assignor to United States Gypsum Company, Chicago, Ill., a corporation of Illinois

Application July 15, 1939, Serial No. 284,719

4 Claims. (Cl. 72-118)

This invention relates to building constructions, and has reference more particularly to ceiling constructions employing cementitious slabs.

In erecting ceilings in buildings underneath supporting beams or joists it is customary to use cementitious slabs of gypsum or the like, these slabs preferably being about two inches in thickness. In attaching said slabs to the beams or joists, it is important to have a manner of erection which will permanently and securely support the slabs. It is also important that labor in erection be reduced to a minimum.

An object of the invention, therefore, is to provide a satisfactory ceiling construction employing cementitious slabs.

Another object of the invention is to provide a slab ceiling construction in which the slabs are firmly fastened to the beams or joists.

A further object of the invention is to provide a slab ceiling construction which may be erected by a single workman with a minimum of erection cost; also to improve building constructions in other respects hereinafter specified and claimed.

Reference is to be had to the accompanying drawing forming a part of this specification, in which

Fig. 1 is a sectional perspective view of my improved ceiling construction,

Fig. 2 is a sectional elevation through the construction,

Fig. 3 is an edge elevation of one of the ceiling slabs, and

Fig. 4 is a sectional elevation through one of the ceiling slabs taken on line 4-4 of Fig. 3.

Referring to the drawing by numerals, beams or joists 10 may be in the form of I beams each having a web 11, top flanges 12 and bottom flanges 13. These beams 10 may be supported in spaced parallel relation by any suitable frame not shown. Slabs 14 of cementitious material, such as gypsum, concrete or the like are provided along each diagonal, longitudinal corner with a lower flange 15 and an upper flange 16. A sinuous reinforcing rod 17 is provided with lower loops 18 embedded in the body of the slab 14 adjacent the flange 15, and upper opposed loops 19 which protrude slightly above the slab 14. A plate 20 or other suitable bar or the like has one end engaging under each of the loops 19 and the opposite end engaging on top of the flange 13 so as to support one edge of the slab 14. It will be seen that the edge of the slab adjacent the flange 16 is supported on the flange 15 of the adjoining slab which is spaced apart from the beam flange

13 to permit ease in erection. Thus only one pair of plates 20 is needed for supporting each slab 14 although a greater number may be used if desired, or a single plate may be used with narrow or lightweight slabs. Some latitude is possible in the spacing of the beams 10 because of the clearance between flanges 13 and loops 19. In order to entirely preclude shifting of the slabs 14, it is preferable but not essential to drive an occasional nail 21 into the slabs 14 adjacent the flanges 13 opposite the loops 19. A plaster layer 22 can be applied to the lower faces of the slabs 14, if desired.

In erecting a ceiling after the supports 10 have been properly positioned, the end of the first slab is supported against a side wall in any suitable manner and the opposite end is then raised so that the slab is flat against, and extends slightly beyond, the flange 13 of the first support. In this position the recessed side of the adjacent edge of the slab is uppermost and the zigzag reinforcing rod 17 is parallel with the supporting flange 13 and the loops 19 are adjacent thereto. The plates 20 are then inserted through the loops and, if desired, a nail 21 inserted to assist in preventing displacement of the slab. The flange 16 of the next slab is then supported on the flange 15 of the erected slab as shown by dotted lines in Fig. 2. The shiplap joint thus established provides a hinge so that one end of the slab is supported while the workman lifts the other end snugly against the second support and inserts the supporting plates 20 in the manner previously described.

By means of the construction illustrated and described, the above method of erection may be practiced and the entire ceiling may quickly and easily be assembled by a single workman at a minimum cost for labor and material.

I would state in conclusion that, while the illustrated example constitutes a practical embodiment of my invention, I do not wish to limit myself precisely to these details since manifestly the same may be considerably varied without departing from the spirit of the invention as defined in the appended claims.

Having thus described my invention, I claim as new and desire to secure by Letters Patent:

1. In a ceiling construction, a plurality of spaced slab supporting runners having at least one outstanding lower flange, a plurality of slabs each having oppositely disposed shiplap edges, said slabs being in mating engagement with one edge of each slab supporting an edge of the next adjacent slab, said one edge being substantially

parallel with and adjacent said flange with its recessed side uppermost and with the slab extending under and materially beyond said runner, each of said slabs along said one edge only having loop-like means projecting upwardly between said flange and said one slab edge, and a comparatively short bar extending through said loop-like means with one end bearing against said slab adjacent said one edge and the opposite end overlapping said flange.

2. In a ceiling construction having flanged runners, a plurality of wall slabs each having oppositely disposed shiplap edges with one or more loops protruding from the surface adjacent the recessed side of one only of said edges, a plurality of bar-like members insertable through respective loops, said slabs being erected with said loops extending upwardly to enable the erection of said ceiling by supporting a flange on the opposite edge of one slab on the projecting flange on the said one edge of a previously erected slab with the said one slab extending angularly downward below a succeeding runner, then raising said one slab against said succeeding runner with its said one edge extending therebeyond and with the said loops along said one edge adjacent a flange and then inserting said bars through said loops so that one end of each of said bars rests on said slab adjacent said one edge and the opposite end of each of said bars rests on said flange to thereby support said one slab on said

runner flange and on the said projecting flange of said first erected slab.

3. A wall structure element for use with flanged supports such as I-beams or the like, comprising a wall slab having oppositely disposed shiplap edges, an elongated reinforcing element embedded in said slab parallel with and adjacent one shiplap edge, said element having spaced loop portions extending from the surface of said slab on the side opposite the flange of said adjacent edge, whereby a bar or the like attaching member may be inserted therethrough with one end bearing on said slab adjacent said one shiplap edge and the opposite end overlapping a flange of said support with said slab extending thereunder and therebeyond.

4. A wall structure element for use with flanged supports such as I-beams or the like, comprising a wall slab having oppositely disposed shiplap edges, an elongated reinforcing wire embedded in said slab parallel with and adjacent one shiplap edge, said wire being of substantially zigzag formation in a plane transverse to the plane of said slab so that spaced sections of said wire protrude from the surface of said slab on the side opposite the flange of said adjacent edge, said protruding sections forming loops permitting the insertion of a plate or the like member therethrough with one end of said plate bearing on said slab adjacent said recessed edge and the opposite end overlapping the flange of said support.

ARTHUR A. HEEREN.