

O. T. PRISER.
MAIL DESK.

APPLICATION FILED DEC. 16, 1906.

Fig. 1.

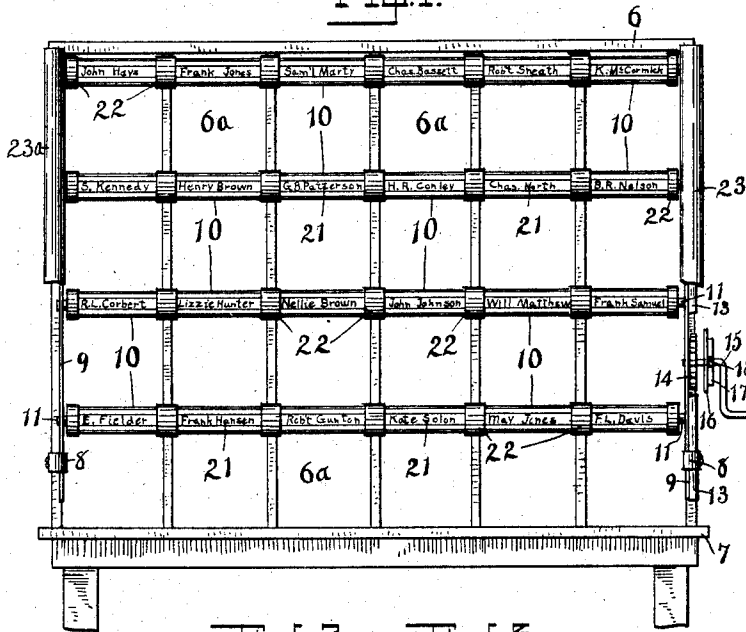

Fig. 5A.

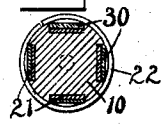

Fig. 5.

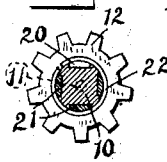

Fig. 2.

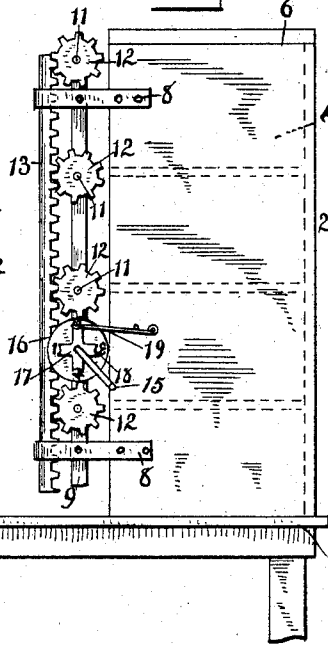

Fig. 3.

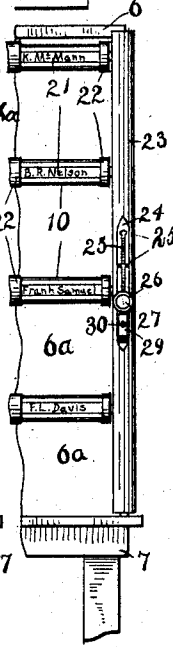
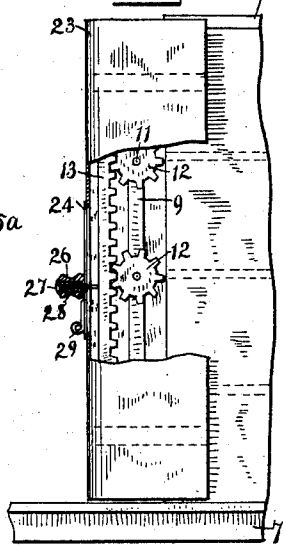

Fig. 4.



WITNESSES:

Chatt. J. Marty

C. F. Bassett

INVENTOR

O. T. Priser

BY *Frederic Benjamin*
ATTY.

UNITED STATES PATENT OFFICE.

ORION T. PRISER, OF BROOKVILLE, OHIO.

MAIL-DESK.

No. 866,218.

Specification of Letters Patent.

Patented Sept. 17, 1907.

Application filed December 15, 1906. Serial No. 348,084.

To all whom it may concern:

Be it known that I, ORION T. PRISER, a citizen of the United States, residing at Brookville, in the county of Montgomery and State of Ohio, have invented certain new and useful Improvements in Mail-Desks, of which the following is a specification.

My invention relates to mail distributing apparatus and refers especially to mailing tables or desks adapted for the use of rural free delivery carriers, although its application is not limited to this class of mail distribution.

The chief objects of my invention are to provide a roster for the names of the patrons on a rural delivery route or a division of the same which will be applicable to the distributing table; to provide means for quickly substituting one list of names for another having a different set of names; to so design the apparatus that it can be used in conjunction with the compartments of mailing tables already in use; to furnish means for limiting the mechanical movement of the roster changing device to correspond with the number of sections into which the roster is divided; and to provide means for quickly changing individual names or removing any desired number of them from the roster.

I accomplish the above and other minor results by the apparatus illustrated in the accompanying drawing which forms a part of this specification and in which:—

Figure 1 is a front elevation of a mail distributing desk showing the apparatus attached thereto; Fig. 2 is an end view of the same with the protective cover removed; Figs. 3 and 4 are fragmentary views showing modifications in the operating mechanism; Fig. 5 is a cross section of one of the rollers showing its gear attached thereto, and Fig. 5^a is a cross section of a roller showing the protective plates for the labels

Referring to the drawing 6 indicates the casing of a mailing desk, provided with compartments 6^a in which the mail is placed, supported upon a table 7. Secured to the ends of the casing are brackets 8 which support vertical plates 9, 9^a. A series of horizontal rollers 10 arranged in parallel series above each horizontal row of compartments are journaled at each end in the plates 9, 9^a. At one end of each roller the journal 10 projects through said plate 9, and has mounted thereon a pinion 12. These pinions are adapted to mesh with a vertical rack 13 which is supported by the brackets 8, which are bent upon themselves near their free ends to form guides for the rack. The latter is operated by reciprocating it vertically by the aid of a gear 14 fixed on a shaft which turns in a bearing in the vertical plate 9. The end of the shaft is bent to form a crank 15. Affixed to the shaft is a circular dial plate 16 provided with numerals arranged at regular intervals on the face of said plate. Secured to the plate 16 is a detent wheel, having radiating arms

17 equally spaced about the axis corresponding in number with the grooves in each roller hereinafter described, and furnished at the ends with notches 18 with which a detent 19 alternately engages as the shaft and wheel revolve. The detent 19 is secured to the casing 6 and is sufficiently flexible to allow the shaft to turn when the hand is applied to the crank, but will exert sufficient pressure to prevent accidental turning.

Each roller is furnished with four longitudinal grooves 20 as shown most clearly in the cross sectional view in Fig. 5. Within these grooves are placed tickets or labels 21 upon which are printed or otherwise impressed the names of the patrons. Each name corresponds with one of the compartments 6^a and the labels are kept in their grooves by collars 22 which may be slipped along the roller when it is desired to change the names and when the label is replaced the collar is slipped back into place where it is held by frictional contact being split for that purpose. Except at the ends of the rollers the collars are placed over the junction of two labels. Coverings 23, 23^a are provided at each end of the apparatus to protect the movable parts.

In Figs. 3 and 4 is shown a modification of the operating device, the gear 14 and its attachments being replaced by the appliance illustrated. To the front edge of the protective casing 23 is attached a plate 24 in which is a slot 25 which registers with a similar slot in the casing 23 and has four notches 25^a spaced equal distances apart. A knob 26 provided with projecting lugs adapted to engage the notches 25^a, is secured to the rack 13 by a bolt 27 which passes through the knob and is fixed in the rack. The knob is recessed to receive a spiral spring 28 which engages the head of the bolt 27 and pressing against the bottom of the recess tends to hold the knob against the plate 24, the lugs 26^a preventing displacement.

It may be desirable in some cases, as for instance in mail cars where the labels would be more liable to injury from the water used in washing the cars, to protect them by a covering of some water-proof transparent material such as glass or celluloid. This will also keep the labels free from dirt and dust. Such an arrangement is seen in Fig. 5^a which is a cross section, enlarged, of a roller in which the labels 21 are covered with protective plates 30.

A stop 29 adjustably secured to the plate 24 and casing 23 by a set screw 30^a, limits the downward movement of the knob and bolt 27 and as the latter is fixed in the rack the movement of the latter is controlled by this means. If the knob is moved from top to bottom of the slot 25 it will move the rack 13 sufficiently to turn all the rollers one revolution. If there are only enough names to require three sides of the rollers to be used then the stop 29 is moved up to the first gradua-

tion from the bottom, in which case the knob can be moved only far enough to show in succession three sets of labels contained in the three grooves required to be used.

5 The method of using the apparatus is as follows: The apparatus being in position as shown in Fig. 1 the carrier will proceed to distribute the mail for that division by placing the pieces in the compartments corresponding with the names. When this division is
10 distributed he turns the crank 15 until the detent 19 engages the next notch 18 in the wheel 17, thus bringing a new list of names into view, when he distributes the mail for that division as before. He proceeds in like manner with each division until all the mail is
15 distributed.

While the rollers have been shown with 4 grooves in each to hold labels, it is evident that this number may be varied as found desirable.

20 It is evident that other changes may be made in the devices of my invention as herein disclosed without departing from the spirit and scope thereof and I do not wish, therefore, to be limited to the precise construction set forth.

25 Having thus described my invention what I claim as new is:—

1. A device for the purpose specified including a series of parallel rollers having labels attached thereto, means for rotating said rollers, means for retaining the rollers in the position to which they are rotated, and means for
30 indicating the positions of the labels.

2. A device for the purpose specified, including a series of revoluble rollers, means for simultaneously rotating the said rollers, means for retaining the rollers in certain predetermined positions, means for indicating said positions, and means for attaching the appliance to a mailing
35 table.

3. A roster for a mailing table, including a series of grooved rollers, labels contained in the grooves, means for rotating the rollers, means for retaining the rollers in certain predetermined positions, means for indicating said positions, a protective cover for the mechanism and means for attaching the appliance to a mailing table.
40

4. The combination with a mailing table containing a plurality of mail boxes or compartments, of a plurality of revoluble rollers, a plurality of labels attached to each of said rollers, means for rotating the rollers simultaneously, means for locking the rollers in certain predetermined positions, means for indicating said positions, a protective cover for the mechanism and means for attaching
45 the appliance to a table.

5. The combination with a mailing table provided with a plurality of mailing boxes, a plurality of grooved rollers located adjacent to said compartments, and provided with labels, of retaining rings for said labels arranged to slide upon said rollers, pinions mounted upon the ends
50 of said rollers, a rack adapted to gear with said pinions, and means for operating said rack.

6. The combination with a mailing table provided with a plurality of mailing compartments, a plurality of
60 grooved rollers located adjacent to said compartments and

provided with removable labels, of retaining rings for the labels arranged to slide upon said rollers, transparent protective coverings for the labels, pinions mounted upon the rollers, a rack adapted to gear with said pinions, means for operating said rack, and a yielding detent for
65 said operative means.

7. The combination with a mailing table provided with a plurality of mail compartments, a plurality of grooved rollers located adjacent to said compartments and provided with series of removable labels, of slidable retaining rings for the labels, transparent protective coverings for the labels, pinions mounted upon the rollers, a rack adapted to gear with said pinions, means for operating said rack, means for indicating the position of the several series of labels, and means for locking the rack operating means.
70

8. The combination with a mailing table provided with a plurality of containers for the mail, a series of grooved rollers located adjacent to said containers, each of said rollers provided with a plurality of series of labels having transparent protective coverings, pinions mounted upon the rollers, a rack adapted to gear with said pinions, means for operating said rack, an indicating disk for designating the position of the series of labels, means for retaining the operative mechanism in position, and means
80 for attaching the device to said table.

9. The combination with a mailing table having a plurality of mail boxes, a series of grooved rollers located adjacent to said mail boxes and provided with a plurality of removable labels for each of said rollers, of pinions mounted upon the rollers, a rack adapted to gear with said pinions, an operating handle attached to said rack, an indicator for designating the position of a series of labels, means for locking the rack in position, and means for attaching the device to said table.
85

10. The combination with a mailing table having a plurality of mail compartments, of a frame, a series of parallel grooved rollers carried on said frame adjacent to said compartments, a plurality of series of labels removably attached to said rollers and provided with removable, transparent protective coverings, pinions mounted upon the rollers, a rack adapted to operate said pinions, a gear provided with an operating handle engaging said rack, an indicating disk attached to said handle, a yielding detent for said handle, and a protective covering for the mechanism.
90

11. A roster for a mailing table including a casing, a plurality of label holding rollers, means for removably securing labels therein, transparent protective plates for said labels, means for rotating said label holders, means for retaining said holders in position when rotated, and means for indicating the various positions of said holders.
95

12. A device for the purpose indicated, including a plurality of casings, a plurality of rollers having longitudinal grooves, a plurality of labels contained in said grooves, means for removably retaining said labels in the grooves, transparent protective plates for said labels, means for rotating said roller simultaneously, means for retaining the rollers in the position to which they are rotated, and means for indicating said position.
100

In testimony whereof I affix my signature in presence of two witnesses.

ORION T. PRISER.

Witnesses:

JAMES M. CUSICK,

JOHN O. BERSF.