

AUSTRALIA

Patents Act 1990

619320

REQUEST FOR A STANDARD PATENT

AND NOTICE OF ENTITLEMENT

The Applicant identified below requests the grant of a patent to the nominated person identified below for an invention described in the accompanying standard complete patent specification.

[70,71] Applicant and Nominated Person:

F & S CORPORATION OF COLUMBUS, GEORGIA of Route 1, Box 992,
Old Smith Road, Fortson, Georgia 31808, United States of
America.

[54] Invention Title:

"APPARATUS AND METHOD FOR PRODUCING COLOR CORRECTED
REPRODUCTIONS OF COLORED ORIGINAL IMAGES"

[72] Actual Inventor:

Fred P. Morgan of Route 1, Box 992, Old Smith Road, Fortson,
Georgia 31808, United States of America.

[74] Address for Service:

PHILLIPS ORMONDE & FITZPATRICK
367 Collins Street
Melbourne 3000 Australia

Basic Convention Application Details:

[31] Application Number: 212,714

[33] Country: United States of America
Country Code: US

[32] Date of Application: 28 June 1988

Applicant states the following:

The nominated person has entitlement from the actual inventor
by assignment.

The basic Convention application was the first made in a
Convention country in respect of the invention the subject of
the application.

DATED: 23 October, 1991.

PHILLIPS ORMONDE & FITZPATRICK

Attorneys for:

F & S CORPORATION OF COLUMBUS, GEORGIA

By:

Donald B. Fitzpatrick

Our Ref.: IRN 195000

(12) PATENT ABRIDGMENT (11) Document No. AU-B-38674/89
(19) AUSTRALIAN PATENT OFFICE (10) Acceptance No. 619320

- (54) Title
APPARATUS AND METHOD FOR PRODUCING COLOR CORRECTED REPRODUCTION OF
COLOURED ORIGINAL IMAGES
- International Patent Classification(s)
(51)⁴ G03F 003/10
- (21) Application No. : 38674/89 (22) Application Date : 26.06.89
- (87) PCT Publication Number : WO90/00267
- (30) Priority Data
- (31) Number (32) Date (33) Country
212714 28.06.88 US UNITED STATES OF AMERICA
- (43) Publication Date : 23.01.90
- (44) Publication Date of Accepted Application : 23.01.92
- (71) Applicant(s)
F & S CORPORATION OF COLUMBUS, GEORGIA
- (72) Inventor(s)
FRED P. MORGAN
- (74) Attorney or Agent
PHILLIPS ORMONDE & FITZPATRICK , 367 Collins Street, MELBOURNE VIC 3000
- (56) Prior Art Documents
US 4482917
US 4468692
- (57) A method according to claim 1 and an apparatus for carrying out the method is claimed(claim 11).

CLAIM

1. A method of operating a processing unit for producing output signals representative of agent color densities of coloring agents such as process inks or toners, to be used in producing a color-corrected image unit of an initial image unit using the coloring agents, the processing unit including memory means for storing selected data, the coloring agents presenting respective agent colors, said method comprising the steps of:

- (a) entering input signals into the processing unit which are respectively representative of color readings of the image unit to be finally produced using said coloring agents;
- (b) determining initial color densities that correspond relatively to said color readings entered into the processing units;
- (c) retrieving from the memory means previously stored data representative of respective contribution factors corresponding to the contribution to each of the agent colors from each of the other coloring agents;
- (d) retrieving from the memory means previously stored data representative of certain predetermined nonlinearity correc-

(11) AU-B-38674/89
(10) 619320

-2-

- tion factors which are representative of the particular coloring agents to be used in producing said image unit;
- (e) calculating in said processing unit, for each agent color of a respective coloring agent, a contribution amount to each of the other agent colors as a function of the effect thereon of the respective initial color density, contribution factor, and correction factor;
 - (f) calculating in said processing unit, for each agent color, a final agent color density as a function of its corresponding initial density and the contribution amounts from the other coloring agents; and
 - (g) producing output signals representative of each of said final agent color densities.

619320
PCT

OPI DATE 23/01/90

APPLN. ID 38674 / 89

AOJP DATE 22/02/90

PCT NUMBER PCT/US89/02839

INTERNATIONAL APPLICATION PUBLISHED UNDER THE PATENT COOPERATION TREATY (PCT)

<p>(51) International Patent Classification ⁴ : G03F 3/10</p>	<p>A1</p>	<p>(11) International Publication Number: WO 90/00267</p>
		<p>(43) International Publication Date: 11 January 1990 (11.01.90)</p>
<p>(21) International Application Number: PCT/US89/02839 (22) International Filing Date: 26 June 1989 (26.06.89) (30) Priority data: 212,714 28 June 1988 (28.06.88) US (71) Applicant: F & S CORPORATION OF COLUMBUS, GEORGIA [US/US]; Rt. 1, Box 992, Old Smith Road, Fortson, GA 31808 (US). (72) Inventor: MORGAN, Fred, P. ; Rt. 1, Box 992, Old Smith Road, Fortson, GA 31808 (US). (74) Agents: DICKEY, Steven, R. et al.; Hovey, Williams, Timmons & Collins, 1400 Mercantile Bank Tower, 1101 Walnut St., Kansas City, MO 64106 (US).</p>	<p>(81) Designated States: AT (European patent), AU, BE (European patent), CH (European patent), DE (European patent), FR (European patent), GB (European patent), IT (European patent), JP, LU (European patent), NL (European patent), SE (European patent).</p> <p>Published <i>With international search report.</i></p>	

(54) Title: APPARATUS AND METHOD FOR PRODUCING COLOR CORRECTED REPRODUCTION OF COLOURED ORIGINAL IMAGES

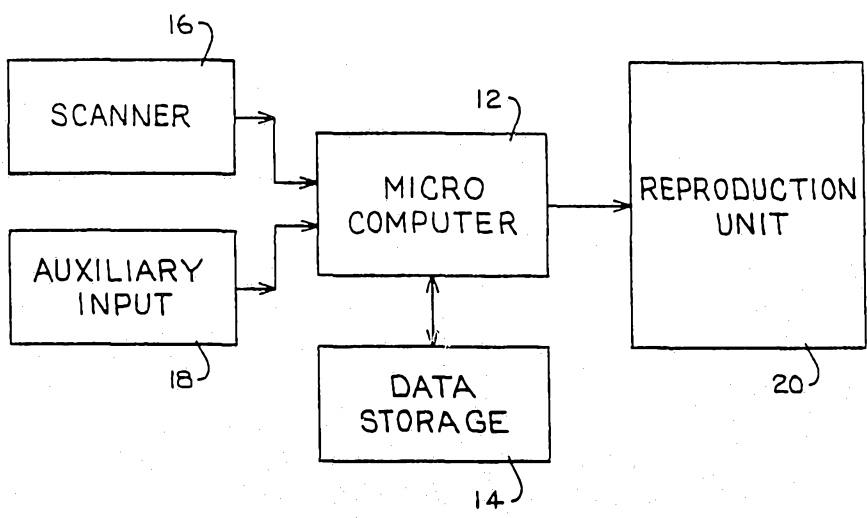

(57) Abstract

A system is disclosed for producing output signals representative of the densities of coloring agents such as process inks, toners, or the like used in producing color reproductions which are color corrected for the effects of linearity failures of the coloring agents at various densities and combinations thereof. The preferred system includes a scanner (16) for providing input signals representative of the primary color readings of an original color image and a microcomputer (12) having a memory (14) for storing data representative of increments of primary color readings and corresponding agent color densities, contribution factors, and contribution correction factors. In use, the microcomputer (12) is operated to determine the final coloring agent densities as respective functions of corresponding initial agent color densities and respective contribution amounts from the other agent colors and to produce output signals representative thereof.

1 APPARATUS AND METHOD FOR PRODUCING COLOR
 CORRECTED REPRODUCTION OF COLORED ORIGINAL IMAGES

5 Background of the Invention

 1. Field of the Invention

 The present invention concerns a system for
 providing output signals representative of color
 corrected color densities of coloring agents used in
10 reproducing a colored original image. More particu-
 larly, the present invention automatically provides
 the output signals representative of the color cor-
 rected color densities in response to input signals
 representative of the primary color readings of the
 original image.

15 2. Description of the Prior Art

 The art of color reproduction strives to
 faithfully reproduce the colors of the original image.
 More particularly, color reproduction strives to
 create a reproduced image which reflects the same
20 spectral colors, typically measured in terms of red,
 green and blue, as the original. Instruments such as
 a densitometer allow quantified readings of the pri-
 mary spectral colors and thereby enable the quality of
 the reproduction to be quantified in numerical terms.
25 A densitometer produces the three primary color read-
 ings of red, green, and blue by separately sensing the
 light transmitted through separate red, green, and
 blue filters. That is to say, a red reading corre-
 sponds to the amount of standardized light passing
30 through a standarized red filter after being reflected
 from a particular portion of the original image.
 Similarly, green and blue readings are produced by
 sensing the light transmitted through respective green
 and blue filters. The red, green, and blue filters

PCT/US 88/0245

IPEA/US
IPEA/US

05 JUL 1990

~~01 AUG 1990~~

- 2 -

IPEA/US

~~05 AUG 1990~~

1 are designed to respectively absorb one-third of the
spectrum reflected from the image centered about the
three primary colors red, green, and blue. As a
5 result, primary color readings are a subtractive pro-
cess which readings represent the remaining light
transmitted through red, green, and blue filters.

In principle, the objective of color repro-
duction is to impress transparent coloring agents on
white paper such that the coloring agents act as ideal
10 primary color filters. Color agents are typically
identified by their process colors of cyan, magenta
and yellow corresponding respectively to red, green,
and blue. Ideally these process colors act as perfect
15 red, green, and blue filters which absorb only their
designated portion of the spectrum and reflect or
transmit the rest.

Unfortunately, practically available commer-
cial coloring agents do not act as perfect red, green,
20 and blue filters. That is to say, typical coloring
agents are not strongly absorbing in one-third of the
spectrum and strongly reflecting or transmitting in
the other two-thirds of the spectrum. For example, a
typical cyan coloring agent which ideally would absorb
25 light only in the red third of the spectrum, also
absorbs light in the green portion and blue portion.
Similarly, typical magenta coloring agents, while
predominately absorbing light in the green part of the
spectrum, also absorb in the red and blue portions,
30 and yellow coloring agents absorb not only the blue
portion of the spectrum but also in the green portion
and the red portion. Hence, coloring agents are said
to contain so-called "dirt" in reference to the fact
that coloring agents do not perform as ideal red,
35 green, and blue filters.

SUBSTITUTE SHEET
IPEA/US



-3-

1 In order to quantify the non-ideal charac-
teristics of coloring agents, each process color for a
particular type of coloring agent can be quantified as
having a certain proportion or percentage of the other
5 two colors. For example, cyan ink at a given density
can be said to include a density level or percentage
of magenta and yellow. That is to say, the green
filtering action in the cyan ink can be characterized
as a certain percentage of magenta in the cyan and the
10 blue filtering action can be characterized as a cer-
tain percentage of yellow. Analogously, a magenta ink
at a given density level can be said to include a
certain percentages of cyan and of yellow, and the
yellow ink can be said to have a certain percentages
15 of magenta and cyan therein at a given density. Thus,
when used in combination, each coloring agent contri-
butes color to the other agent colors and the amount
of contribution is different at different densities.
This contribution effect must be taken into account in
the color correction process.

20 The color correction process is additionally
complicated by the fact that typical coloring agents
experience so-called "linearity" failures such as
"proportionality" failure and "additivity" failure.
Proportionality failure refers to the fact that the
25 color density of an agent color as measured by a
densitometer does not increase linearly as the print-
ing density of the coloring agent increases. That is,
when the printing or coverage density of a cyan ink is
increased, the measured cyan color density does not
increase linearly therewith. Additionally, as the
30 cyan ink density increases the magenta and yellow
contributions also do not increase linearly.

 Additivity failure refers to the fact that
when two or more coloring agents are combined, the

35

-4-

1 contribution one makes to the other does not increase
or add linearly. For example, a cyan ink at a given
density level has a certain cyan color density. A
5 magenta ink at a given density level also contains a
certain cyan density. If the cyan from the cyan ink
and the cyan from the magenta ink combined linearly,
the total cyan density reading of the combination
would be a simple sum of the cyan density from the
cyan ink and the cyan density contributed by the
10 magenta ink. However, the resulting combination
typically produces a net cyan density reading less
than the sum of the two cyan sources. Thus, the cyan
densities fail to add linearly.

As can be appreciated from the discussion
above, the problems of color correction are substan-
15 tial. In lithography, color correction is typically
achieved by masking techniques in which the litho-
grapher produces color separation masks used for
producing printing plates which are designed to pro-
duce the desired color correction. The masking tech-
20 niques, while generally effective, are also time
consuming and expensive and may be prohibitively
expensive for short runs of printing material.

Another color correction technique concerns
the use of a microcomputer and associated electronic
25 memory in which primary color reading data is stored
therein corresponding to color charts of the coloring
agents to be used in the reproduction process. The
color agent charts for a given type of coloring agents
are composed of patches of various combinations of the
30 three colors of coloring agents at various color
densities. If fifteen density steps of the three
agent colors are used to make the charts, 3,375 combi-
nations are possible with each producing corresponding
red, green, and blue readings. This data is typically

35

-5-

1 arranged in the form of a table and the patch is
selected having red, green, and blue readings which
correspond most closely with the desired red, green,
and blue readings.

5 As those skilled in the art will appreciate,
a lookup table so constructed is limited in its color
correction accuracy. For example, fifteen density
steps for each process color produces increments of
6.67% for each step. With this large a gap between
10 steps, the color correction may be inaccurate by at
least this amount. If a minimum 3% accuracy is re-
quired, data must be produced for about 33 steps of
density for each process color. This increases the
number of color patches to almost 36,000. If accuracy
of 1% is desired, data corresponding to nearly
15 1,000,000 patches must be stored.

Thus, to increase the color correction
accuracy using such tables, the amount of memory space
increases by the cube of the number of density steps.
Additionally, six bytes of data must be stored for
20 each patch corresponding to a byte of data for each
process color in the combination and a byte of data
for each primary color reading produced by that color
patch. Thus, for 1% accuracy, at least 8,000,000
bytes of data must be stored. As those skilled in the
25 art will appreciate, this volume of data becomes
unwieldy to produce and enter, expensive to store, and
time consuming to retrieve. Furthermore, this data is
usable only for a particular set of inks and must be
re-entered for different inks. That is to say, a new
30 look-up table is required if the inks are changed. As
a result of these problems, electronic color correc-
tion is not in widespread use.

35

1 Summary of the Invention

5 The problems as outlined above are solved by the system of the present invention. That is to say, the system hereof allows for highly precise and automatic color correction without the need for unwieldy amounts of data stored in memory.

10 Broadly speaking, the preferred system uses a microcomputer to receive input signals representative of the primary color readings for each image unit, pixel, or line of the image to be reproduced. In response, the microcomputer calculates final agent color densities as a function of color densities corresponding to the desired primary color readings, corresponding color contribution factors, and corresponding correction factors. The microcomputer then produces output signals representative of the final agent color densities for each agent color such as cyan, magenta and yellow. The output signals are preferably used in a reproduction unit capable of producing variable dot sizes of the coloring agent to produce the color densities of the coloring agents as represented by the output signals.

15
20
25 In particular forms, the system hereof also accounts for variations in the correction factors which occur at different density combinations of the coloring agents. Advantageously, the system also provides for gray component removal for four color reproduction using cyan, magenta, yellow, and black in which the black replaces portions of the other colors to achieve the same color density result. The invention hereof also provides for black enhancement used to emphasize shadows.

30
35 Other preferred aspects of the invention will be explained hereinbelow.



-7-

1 Brief Description of the Drawing Figures

Figure 1 is a schematic representation of the preferred components of the present invention;

5 Fig. 2 is a computer program flowchart illustrating the SET-UP module of the computer program for operating the microcomputer of Fig. 1;

Fig. 3A is a computer program flowchart illustrating the first part of COLOR CORRECTION module of the computer program;

10 Fig. 3B is a computer program flowchart of the CYAN CORRECTION submodule of the computer program;

Fig. 3C is a computer program flowchart of the MAGENTA CORRECTION submodule of the computer program;

15 Fig. 3D is a computer program flowchart illustrating the YELLOW CORRECTION submodule of the computer program;

Fig. 4 is a computer program flowchart illustrating the BLACK ENHANCEMENT module of the computer program;

20 Fig. 5 is a computer program flowchart of the GRAY COMPONENT REMOVAL module of the computer program;

Detailed Description of the Preferred Embodiment

25 Fig. 1 illustrates preferred apparatus 10 including microcomputer 12 having associated data storage unit 14, scanner 16, auxiliary input device 18, and reproduction device 20.

30 Preferred microcomputer 12 is a WYSE 386 Computer Model WY3216-01 having an INTEL 80387 math coprocessor, INTEL ABOVE BOARD 286 with 2048 K expanded memory, a general purpose interface board for interfacing with the scanner, and an AT&T TARGA- 24 board. Microcomputer 12 also includes a conventional

35

-8-

1 color monitor (not shown) such as Mitsubishi type 1371
and a conventional data entry keyboard (not shown).

5 Data storage unit 14 is conventionally
interconnected with microcomputer 12 and preferably
includes a 40 megabyte hard drive and two 1.2 megabyte
floppy disk drives.

10 Preferred scanner 16 is a HOWTEK SCANMASTER
manufactured by Sharp Electronics (Type JX 450).
Scanner 16 is operable to scan a colored original
image in order to produce corresponding red, green,
and blue color density readings for each pixel which
are presented as input signals representative of these
RGB readings for reception and use by microcomputer
12.

15 Auxiliary input device 18 is an auxiliary
source such as a conventional MACINTOSH microcomputer
of input signals representative of desired red, green,
and blue readings of an image to be produced by repro-
duction device 20. Scanner 16 and device 18 are both
operable to provide input signals to microcomputer 12
20 representative of the desired RGB readings of the
image to be reproduced. Scanner 18 develops these
desired RGB readings by scanning a colored original
image. Device 18, in contrast, provides output sig-
nals representative of the RGB readings as produced on
25 the color monitor associated with the preferred MACIN-
TOSH microcomputer, for example. Those skilled in the
art will appreciate that other devices may be used to
supply input signals to microcomputer 12 such that the
signals represent desired RGB readings or color dens-
30 ity readings of the reproduced image.

Reproduction device 20 is preferably a three
or four color reproduction device operable to produce
varying dot sizes of each coloring agent in response

35

1 to output signals from microcomputer 12. Preferred
reproduction device 20 is film recorder such as a
QZR-2 MATRIX brand capable of continuous gray tone
5 film negative production. Other suitable reproduction
devices include thermal printers, ink jet printers,
and xerographic printers including laser printers
operable for color printing and preferably for pro-
ducing variable dot sizes as a function of desired
10 color density.

10 Figs. 2-5 are computer program flowcharts
illustrating the preferred method of operating appara-
tus 10 and, in particular, microcomputer 12 for pro-
ducing output signals representative of the final
15 agent color densities of the coloring agents used in
reproduction device 20. In preferred forms, the
computer program is written using Borland Interna-
tional Turbo Basic Version 1.1, 1987. Additionally,
other software used in operating microcomputer 12
20 includes AT&T - Flamingo Graphics Soft Vision RIO
Version 1.2, AT&T - Flamingo Graphics RIO-PCS Version
1.33, and True Vision Image Processing Image Software
from Island Graphics.

25 In implementing the method of the present
invention, it is first desirable to set up data files
particular to the coloring agents being used by repro-
duction unit 20 to reproduce a given image. These
data files are set up for primary color readings,
preferably and typically red, green, and blue (RGB),
30 and the coloring agent colors, preferably and typic-
ally, cyan, magenta, and yellow (CMY).

35 In general, SET-UP module 200 produces
respective lookup tables for 256 increments of RGB
readings corresponding to respective CMY densities.
CMY densities are typically read from color charts of
coloring agents using a conventional densitometer with



1 the CMY densities in 12 to 15 ink density increments
or steps. The RGB readings from these CMY densities
steps are matched with the corresponding RGB readings
5 on the lookup table and other RGB readings are extra-
polated to complete the lookup table. Additionally,
SET-UP module 200 enters contribution factors as
percent contribution of agent colors for each step of
the CMY densities and also enters corresponding con-
10 tribution correction factors explained further herein-
below.

SET-UP module 200 enters at step 202 which
allocates an array for 256 increments of RGB readings
from zero to 255. Step 202 also allocates an array
15 for the corresponding CMY density steps S and cor-
responding contribution factors at each agent color
density step.

The program then moves to step 204 in which
enters the CMY densities D for each step S from the
20 color charts as CD(S), MD(S), and YD(S).

The program then moves to step 206 in which,
for each CMY density step, the corresponding contri-
bution factor to the other agent colors is entered.
For example, for each cyan density step, the percent
25 magenta in cyan (%MC) and the percent yellow in cyan
(%YC) for that step are entered in association with
that step. Similarly, for each magenta step, the
percent cyan in magenta (%CM) and the percent yellow
in magenta (%YM) at that density level is entered and
30 for each yellow density step, the percent cyan in the
yellow (%CY) and the percent yellow in the magenta
(%YM) are entered.

In step 208, the corresponding RGB readings
are entered for each CMY density step S. This pro-
35 duces a red reading for each of the cyan step, a green
reading for each magenta step, and a blue reading for

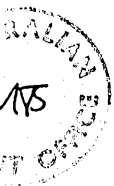

-11-

1 each yellow step. Additionally, the RGB readings for
the reproduction carrier such as white paper are also
entered which represent the respective upper limits of
reproducible RGB readings. The RGB readings for the
5 carrier are necessary to define the upper RGB limits
of the reproduced image. That is to say, the repro-
duced image cannot produce RGB readings greater than
the RGB readings of the carrier without any coloring
agent thereon.

10 The program then moves to step 210 in which
the program retrieves the respective RGB readings for
each CMY step as $R(S)$, $G(S)$, and $B(S)$. For example,
for cyan density step 3, the corresponding red reading
is denoted as $R(3)$. Step 210 also retrieves corre-
sponding cyan, magenta and yellow densities for step S
15 designated as $CD(S)$, $MD(S)$, and $YD(S)$.

In step 212, the variable J is initially set
at 255. Additionally, for step $S=0$, the corresponding
CMY densities are defined as zero such that CMY densi-
ties increase as steps S increase. Conversely, the
20 corresponding RGB readings for step $S = 0$ are set at
the respective RGB readings for the particular white
paper or other carrier which were entered in step 208
which are the RGB readings when the coloring agent
densities are zero.

25 The remaining portion of SET-UP module 200
extrapolates respective RGB readings to fill in the
gaps between corresponding CMY density steps. That is
to say, the RGB array is set up for a maximum of 256
increments but the initial data entered for correspon-
30 ding CMY densities and corresponding RGB readings
typically spans only 15 steps from the color charts.
Accordingly, it is necessary to extrapolate the RGB
readings between the CMY density steps. This extra-
polation process in the remaining portion of SET-UP

35

-12-

1 module 200 is done as a linear function between steps
which, in the preferred embodiment, is sufficient to
provide accurate results. As those skilled in the art
will appreciate, a least squares method or other
5 mathematical techniques could be used instead to
produce a smooth curve through the data points from
the color charts which might be desirable in some
applications.

10 The extrapolation process for red and cyan
begins at step 214 which sets $S = 1$. The program then
moves to step 216 which asks whether variable J is
greater than the red reading at cyan step one minus
one. During the first pass through these program
steps, $J = 255$ and the red reading at step 1 might
15 equal 225, for example. Thus, J at 255 is greater
than $225 - 1$ and the answer in step 216 is yes. The
program then moves to step 218 to conduct a series of
calculations in order to extrapolate the red readings
between step S and step $S - 1$. In the initial step,
with $S = 1$, program step 218 extrapolates between
20 density step 0 and density step 1.

In step 218, the program first calculates
the red span RP according to the formula shown. The
program then calculates the red increment RI between
the next lowest step and the current value of J .

25 Next, the program calculates an incrementing
factor F by dividing the red increment by the red
span. The program then calculates the cyan span CP
between step S and the previous step according to the
formula shown and then calculates an extrapolated cyan
amount as factor F times the cyan span. The program
30 then calculates the cyan density at the J location in
the RGB array as the density of the next lower step
plus the cyan increment CE . In step 219 the program
asks whether $C(J)$ is less than zero which occurs when

35

-13-

1 J is greater than the R reading when the cyan density
is zero at density step zero. If yes, the program
moves to step 220 to set C(J) at zero or a very low
5 number, .0001 in the preferred program. After 220 or
if the answer in step 219 is no, the program moves to
step 221 in which the cyan density C(J) is then stored
at location R(J) in the red array.

By way of example, the red reading at step 1
which is the first density step of cyan might equal
10 225 and R(0) might be 250 which is the red reading of
the carrier. Thus, $RP = 250 - 225 = 25$. If J equals
235, for example, $RI = 250 - 235$ which equals 15, and
incrementing factor F is $15 \div 25$ which equals .60. If
15 the cyan density at step 1 is .11, for example, then
the cyan span CP between step 0 and step 1 is also
.11. Accordingly, the cyan extrapolated value CE is
.60 x .11 or .066. Thus, the cyan density at location
J equals the cyan density at step 0 which is zero
plus .066 or rounded to .07. The cyan density value
is then stored at location R(225) in the red array.
20 Thus, input signals representing a red reading of 225
correspond to a cyan color density of .07. Input red
readings greater than 250 would have a corresponding
cyan density of zero (or .0001 as preferred from step
220).

25 If the answer in step 216 is no indicating
that variable J has been decremented below the red
reading value at cyan density step S, the program
moves to step 222 which increments variable S and then
moves to step 223 which asks whether variable S is
30 greater than the maximum value of S. In the example
above, the maximum value of S is 15 corresponding to
the 15 steps on the cyan density color chart. If the
answer in step 223 is no, the program loops back to
step 216.

35

-14-

1 If the answer in step 223 is yes or after
step 221, the program moves to step 224 which again
sets variable S equal to 1. Steps 224 through 231
perform the same calculations for the green and
5 magenta as for red and cyan in order to extrapolate
the magenta readings for the green array in the same
manner as steps 214-223 for red and cyan.

 Similarly, steps 232-241 perform the same
steps and calculations for blue and yellow.

10 If the answer in step 241 is yes or after
step 239, the program moves to step 242 to decrement
variable J and then moves to step 244 which asks
whether variable J equals zero. If no, the program
loops back to step 214 to complete steps 214-241 for
15 the new value of J. In this way, the program fills in
corresponding CMY extrapolated densities in respective
RGB arrays for each value of J. When complete, each
RGB array presents a complete set of corresponding CMY
densities - up to 256 CMY density increments in the
20 preferred embodiment. In this way, rather than work-
ing with only 15 density increments for each agent
color, up to 256 increments are available which allow
calculation of final density readings within about 1%
of the original.

25 When the answer in step 244 is yes, the
operation of SET-UP module 200 is complete.

30 As discussed above, SET-UP module 200 is
executed once for each set or type of coloring agents
being used in reproduction unit 20. Thus, once the
corresponding CMY densities have been calculated for
each RGB increment in the corresponding arrays, SET-UP
35 module 200 need not be again executed. As a matter of
design choice, the RGB arrays can be set up by the end
user by physically taking a set of RGB readings and
corresponding CMY densities for each of the corre-

-15-

1 sponding CMY densities from color charts of the color-
ing agents with which the reproduced image is to be
printed which typically involves 15 measurements for
each coloring agent for a total 45 measurements. In
5 the alternative, the array and factors can be provided
on a floppy disk or read-only-memory (ROM) chip from
the manufacturer of the coloring agents.

10 Figs. 3A, B, C, and D illustrate the com-
puter program flowchart for receiving input signals
representative of RGB data and for producing output
signals representative of color corrected CMY dens-
ities of the reproduced image in order to produce
corresponding RGB readings.

15 Figs. 3A-D illustrate COLOR CORRECTION
module 300 which includes a CYAN CORRECTION submodule
(Fig. 3b), a MAGENTA CORRECTION submodule (Fig. 3c),
and YELLOW CORRECTIGN submodule (Fig. 3d).

20 Referring now to Fig. 3A, COLOR CORRECTION
module 300 performs a set of initial calculations
based on the input signals representative of the RGB
readings of the colored original, the contribution
factors to each coloring agent from the others, and
corresponding correction factors.

25 The correction factors to be entered in step
206 (Fig. 2) are specific to the particular coloring
agents being used. J.A.C. Yule, in a book entitled
"Principles of Color Reproduction" published by John
Wiley & Sons, New York, which is hereby incorporated
by reference, suggested that correction factors could
be calculated using a series of simultaneous equa-
30 tions. These equations are identified as equations
10.24 on page 278 of the Yule book. Solving of these
simultaneous equations is not usually practical be-
cause of the number of independent variables that must

35

1 be factored into the attempted solution. When simplified, the equations may be represented as:

$$\begin{aligned} C_T &= C_C + aM_C + bY_C \\ M_T &= M_M + dC_m + eY_M \\ 5 \quad Y_T &= Y_Y + fC_y + gM_Y \end{aligned}$$

wherein the total color density of an agent color is expressed in terms of the contribution from the coloring agent of that color plus the contribution to that agent color from the other agent colors. For example, 10 the first equation recites that the total cyan color density C_T equals the sum of: the cyan contribution from the cyan coloring agent C_C , a correction factor "a" times the magenta coloring agent contribution to cyan M_C , and a correction factor "b" times the yellow 15 contribution to cyan Y_C . Similarly, the magenta total M_T is expressed in terms of the magenta agent contribution to magenta M_M plus correction factors "d" and "e" times the respective contributions to magenta from 20 the cyan and yellow coloring agents. The total yellow density Y_T is expressed as a function of the yellow coloring agent contribution of the yellow Y_Y plus correction factors "f" and "g" respectively times the cyan and magenta coloring agent contributions to 25 yellow.

Yule and others made a concerted effort to quantify the linearity failures which occur when coloring agents are combined in practice by resorting to equations such as those referenced above. As 30 pointed out though, the usefulness of these equations requires knowledge of a significant number of independent variable correction factors including at least a, b, d, e, f, and g, all of which are different for different coloring agents. These correction factors 35 necessarily change as the density of combined coloring agents vary. This has heretofore prevented practical



1 application of Yule-type equations in solving color
correction problems.

5 On the other hand, if the independent vari-
ables, a to g inclusive, are first empirically deter-
mined by taking density readings at strategic loca-
tions on color charts of the coloring agents to ulti-
mately be used, then it is possible to solve the
simultaneous equations. For example, as an initial
10 starting point, correction factor "a" can be deter-
mined by reading a previously prepared color chart
patch having a known density of cyan and magenta and
no yellow and solving the first equation above for "a"
using these measured values. A color patch is then
15 read using a densitometer of known densities of cyan
and yellow with no magenta. These values may be used
in the first equation to solve for "b". With these
starting points for correction factors "a" and "b",
color patches may then be read for a cyan density hav-
ing known densities of all three colors - cyan, magen-
20 ta, and yellow. If the equation does not balance,
factors "a" and "b" are altered until the equation
does balance. This process is repeated for the other
two equations until values have been determined for
25 factors d, e, f, and g. In a typical set of match
print inks, these correction factors have been found
to be .6, .6, .4, .4, .5, and .6 respectively for a-g
inclusive and yield acceptable results.

30 It has further been found though that the
values of the correction factors vary somewhat over a
given range of densities. Within certain limits, as
will be explained further hereinbelow, these varia-
tions are small enough so that they do not signifi-
cantly affect the precision of the color correction
35 process within certain density limits. That is to
say, even with these slight variations, the precision

*intensive
step*



-18-

1 of the color correction process is well within accept-
able limits and significantly superior to known prior
art techniques.

5 The three modified equations recited above
can be rearranged as follows:

$$C_c = C_T - aM_c - bY_c$$

$$M_M = M_T - dC_M - eY_M$$

$$Y_Y = Y_T - fC_Y - gM_Y$$

10 In this form, these equations state that the color
density of an agent color equals the total color dens-
ity for that color less the contributions from the
other colors. In other words, if an initial color
density is known, and if the contributions to that
density from the other colors are known, then the re-
15 quired color density of the corresponding coloring
agent can be derived. In the preferred embodiment,
 C_T , M_T , and Y_T correspond to the respective initial
color densities CJ, MJ, and YJ from the RGB arrays and
 C_c , M_M , and Y_Y correspond to the final agent color
densities CF, MF, and YF as will be explained further
20 hereinbelow.

The program enters COLOR CORRECTION module
300 at step 302 which defines a set of files for each
pixel P or image unit of the image to be reproduced.
As will be explained further hereinbelow, the output
25 signals from microcomputer 12 represent agent color
densities for each image unit, pixel, or line of the
reproduced image. For example, in lithographic art,
halftone resolution is expressed in terms of so-called
"lines per inch". Image resolution can also be ex-
30 pressed in terms of pixels per inch with the term
"image unit" as used herein being a generic term for
pixels, lines, or the like. The particular scanner 22
being used may be capable of resolving an original
image with a resolution greater than that of the par-

35

1 ticular reproduction unit 20 being used, or greater
than that needed or desired.

5 In such a case, it may be desirable to average
pixel subsets of the RGB data represented by the
input signals to microcomputer 12 to provide corre-
spondence with the resolution of the reproduced image.
For example, if the final image is to have a resolu-
10 tion of 150 lines per inch and the input provides re-
solution of 300 per inch, the RGB data from four adja-
cent input pixels can be averaged to present the data
corresponding to a single larger reproduction image
unit.

15 Step 302 sets up files for input RGB data,
final CMY density data, and a file K for black data
corresponding to either GRAY COMPONENT REMOVAL or
BLACK ENHANCEMENT as will be explained in connection
with Figs. 4 and 5.

20 The program then moves to step 304 to re-
ceive the input signals representative of the RGB data
for each pixel P which data represents the desired RGB
data for the reproduced image. In the preferred
embodiment, program step 304 corresponds to the physi-
cal operation of placing the colored original drawing
25 in scanner 16 for scanning thereby and for generating
and transmitting the input signals to microcomputer
12. Equivalently, program step 304 corresponds to the
reception of input signals representative of the RGB
data from some auxiliary source such as a MacIntosh
30 computer or data already stored in memory, or some
other input signal source such as a xerographic copier
capable of supplying input signals representative of
primary color readings or equivalent color densities.

35 Step 306 sets variable P equal to 1 and re-
trieves the RGB data corresponding to pixel P.



1 The program then moves to step 308 which
retrieves the respective CMY initial color densities
corresponding to the input RGB data from the corre-
5 sponding RGB arrays. The corresponding CMY initial
color densities are represented as CJ, MJ, and CJ
respectively.

 The program then moves to step 310 which
asks whether any of the corresponding CMY densities
10 CJ, MJ, or YJ are equal to zero. If such is the case,
the program moves to step 312 which sets the density
for that color at a extremely low number corresponding
to zero. That is to say, in the particular program-
15 ming language used in the equation used further here-
inbelow, the variable CJ, MJ, or YJ are not set ex-
actly equal to zero but set at a very low number to
avoid computational problems.

 If the answer in step 310 is no or after
step 312, the program moves to step 314 to retrieve
20 the contribution factors corresponding to the color
densities retrieved in step 308. More particularly,
the contribution factors are expressed as percent
magenta in cyan %MC, and percent yellow in cyan %YC
which preferably correspond to the cyan density step S
25 nearest the cyan density CJ retrieved in step 308.
Similarly, the percent cyan in magenta %CM and the
percent yellow in magenta %YM for the magenta density
MJ are retrieved as the corresponding contribution
30 factor of the magenta density step having a density
value nearest retrieved density MJ. Similarly, the
percent cyan in yellow %CY, and percent magenta in
yellow %MY associated with the yellow density step
having a density value nearest the density YJ are re-
35 trieved.

 As those skilled in the art will appreciate,
these contribution factors as measured from a color



1 chart of the coloring agents also vary non-linearly.
For example, the percent magenta in cyan may be higher
lower at a low density cyan density step and lower at
a high density cyan density step. Program step 314
5 retrieves the contribution factors associated with the
density step nearest the density retrieved in step
308. Such a retrieval treats the variations in con-
tribution factors between density steps as disjointed
10 functions. In the preferred embodiment, this approxi-
mation is close enough to allow precise color correc-
tion. As a matter of design choice, however, the
contribution factors can be extrapolated in a manner
similar to the color density extrapolation performed
15 in SET-UP module 200 if a closer approximation is
desired. Furthermore, if an even closer approximation
is desired, the least squares method of calculating
the contribution factors can also be performed such
that a set of 256 contribution factors corresponding
20 to each of the 256 densities is produced.

The program then moves to step 316 which
calculates two contribution amounts for each agent
color as a function of the corresponding contribution
factor, correction factor, and initial color density.
25 As explained above, the contribution correction fac-
tors a, b, d, e, f, and g are specific to the coloring
agents being used in reproduction unit 20. Similarly,
the contribution factors retrieved in steps 314 are
also specific to the coloring agents being used as
30 they are measured directly from the color charts of
the coloring agents. The contribution amounts calcu-
lated in step 316 are expressed as cyan contribution
to magenta CCM, cyan contribution to yellow CCY,
magenta contribution to cyan MCC, magenta contribution
35 to yellow MCY, yellow contribution to cyan YCC, and
yellow contribution to magenta YCM.

-22-

1 With the calculations complete in step 316,
the program is ready to move on to the cyan, magenta,
and yellow correction submodules in order to calculate
final densities for each coloring agent.

5 The program enters the CYAN CORRECTION sub-
module (Fig. 3b) at step 318. This step is included
to determine whether the contribution to cyan from the
magenta coloring agent or the yellow coloring agent is
greater than the initial cyan density CJ. If such is
10 the case, then no cyan coloring agent need be included
in the final combination. Accordingly, the final cyan
density CF for the cyan coloring agent is set at zero
in the preferred case at an extremely low value in
step 320.

15 If the answer in step 318 is no, the program
moves to step 320 which asks whether the cyan contri-
bution from the yellow coloring agent is greater than
a predetermined factor (in this case 0.6) times the
cyan contribution to the cyan without the magenta
contribution to cyan. In other words, if the contri-
20 bution to cyan from the yellow coloring agent is
greater than a predetermined amount, then the actual
yellow contribution to cyan (YCC) must be recalcu-
lated, recalling that the yellow contribution to cyan
(YCC) was calculated in step 316 as a function of
25 correction factor "f". As discussed above, this
correction factor is generally acceptable except for
coloring agent blends at high densities such that the
yellow agent contributes substantially to the percent
of cyan. If such is the case, then correction factor
30 "f" does not produce precise color correction results
and should be recalculated. Accordingly, the yellow
contribution to cyan (YCC) must be recalculated be-
cause with this great of a cyan contribution from the
yellow, the yellow contribution to cyan becomes more

35

1 dominant and the resulting additivity failure is less.
That is, for example, instead of a 60% correction, 80%
may be more precise.

5 Thus, if the answer in step 320 is yes,
indicating that the yellow does contribute a substan-
tial amount to the cyan as indicated by the formula in
step 320, the program moves to step 322 which calcu-
lates an interim variable "Z" according to the formula
10 shown. Variable "Z" can be thought of as a ratio
between the yellow contribution to cyan and a percent
of the cyan contribution to cyan without the effect of
the magenta contribution to cyan.

The program then moves to step 324 which
15 asks whether variable "Z" is greater than 2. If yes,
the program moves to step 326 to set "Z" equal to 2
with this being a preferred upper limit for "Z".

If the answer to step 324 is no, or after
step 326, the program moves to step 328 to calculate a
20 new value for the yellow contribution to cyan YCC
according to the formula shown in step 328. An in-
spection of this formula indicates that the term
enclosed in brackets is a new calculation for cor-
rection factor "f" in the corresponding formula of
25 step 316.

As those skilled in the art will appreciate,
the multiplication factor 0.6 used in steps 320 and
322 and the addition factor .7 used in step 328 are
specific to the coloring agents being used. In other
30 words, by using sample patches on a set of color
charts of the coloring agents, and by using formulas
in steps 320, 322, and 328, one can determine the
appropriate factors for use in steps 320, 322, and
328. The particular factors .6 and .7 are preferred
35 for match print inks.

-24-

1 If the answer in step 320 is no, or after
step 328, the program moves to step 330 which begins a
series of steps similar to steps 320-328 in order to
recalculate correction factor "d" from step 316 if
5 necessary. In other words, if the magenta contribu-
tion to cyan is greater than .8 times the cyan contri-
bution to cyan without the effects of the yellow
contribution to cyan, then it is necessary to recal-
10 culate correction factor "d". With magenta in the use
of match print inks, it has been found that the cor-
rection factor "d" needs to be recalculated if the
magenta contribution to cyan is greater than 80% of
the cyan contribution to cyan without the effects of
yellow contribution to cyan. This factor .8, is in
15 contrast to the factor .6 used in step 320 and is, as
explained, readily derived.

 If the answer in step 330 is yes, the pro-
gram moves to step 332 to again calculate interim
factor "Z" accordingly to the formula shown and simi-
lar to step 322. Steps 334, 336, and 338 are similar
20 to steps 324-328 as explained above except that step
328 recalculates the contribution of the amount of the
magenta contribution to cyan (MCC) by recalculating
correction factor "d" according to the term as shown
in brackets in step 338.

25 If the answer in step 330 is no, or after
step 338, the program moves to step 340 which calcu-
lates the final cyan color density CF according to the
formula as shown. Basically this formula states that
the final color density of the cyan coloring agent is
30 equal to the initial cyan color density CJ correspond-
ing to the desired red reading less the magenta con-
tribution to cyan (MCC) and less the yellow contribu-
tion to cyan (YCC). This formula incorporates magenta
and yellow contributions to cyan as originally calcu-

35

1 lated in step 316 or as recalculated in steps 328 or
338 as explained above. Also as explained above, if
the magenta or yellow contribute sufficiently to the
cyan such that no cyan coloring agent is needed, the
5 final cyan density is set at a very low number in step
320 and step 340 is bypassed.

After step 340, the program moves to step
342 (Fig. 3C) which initiates the calculations for the
10 MAGENTA CORRECTION submodule. This submodule includ-
ing steps 342-366 performs the same calculations for
magenta as were performed for cyan in steps 318-340
resulting in a final density for the magenta coloring
agent as calculated in step 366. Steps 354 and 364
15 respectively recalculate the cyan contribution to
magenta and the yellow contribution to magenta by
recalculating contribution correction factor "a" and
correction factor "g".

After step 366, the program moves to step
20 368 (Fig. 3D) to initiate the calculations for the
yellow correction in steps 368 through 392 in the same
manner as for magenta and cyan. Note that in steps
372, 374, 380, 382, and 384 that the preferred form of
the formulas is slightly different than the corre-
25 sponding steps for the cyan and magenta calculations.
The difference in the form of equations is primarily
due to the fact that typically available yellow color-
ing agents such as process inks are not as "dirty" as
magenta and cyan and thereby function more nearly like
30 an ideal blue filter. As those skilled in the art may
appreciate, however, with other process inks or toners
or other types of coloring agents, such may not be the
case and the more general form of the formulas as used
35 for calculating cyan and magenta may be necessary.

After step 392, the program has completed
the calculations for the final color density for each

SUBSTITUTE SHEET
IPEA/US



-26-

1 coloring agent and has stored these values for pixel
P. After step 392, the program moves to step 393
which asks whether pixel P is to include enhancement
black as will be explained in connection with Fig. 4.
5 If yes, the program goes to BLACK ENHANCEMENT module
400 and executes that submodule and reenters the
program at entry point "D".

If the answer in step 393 is no, the program
moves to step 394 which asks whether GRAY COMPONENT
10 REMOVAL module 500 (Fig. 5) is to be executed as will
be explained further hereinbelow. If yes, the program
executes module 500 and then returns at entry point
"D". As those skilled in the art will appreciate,
both enhancement black and undercolor removal are
15 typically not both used. Additionally, the particular
reproduction unit 20 being used may not have the
capability of a four color process incorporating black
in which case the answers in steps 393 and 394 are
both no.

If the answer in step 394 is no or after
20 execution of modules 400 or 500, the program moves to
step 395 which increments pixel variable P. The
program then moves to step 396 which asks whether P
exceeds the maximum number of pixels in the reproduced
image. If no, the program loops back to step 308
25 (Fig. 3A) to reexecute steps 308-396 for the next
pixel.

If the answer in step 396 is yes, the pro-
gram moves to step 397 to send output signals to
reproduction unit 20 representative of the CMY densi-
30 ties for each coloring agent for each pixel. In the
alternative, the output signals can be sent instead
for conversion to data for storage in data storage
unit 14. That is to say, the CMY data can be down-
loaded onto a floppy disk, for example, and stored

35

1 thereon. As preferred, the output signals represent
the CMY color densities which can be converted to
represent percent dot sizes as will be explained
further hereinbelow.

5 Fig. 4 illustrates BLACK ENHANCEMENT module
400. As those skilled in the art will appreciate, if
a four color process is desired or available, black is
often added for enhancing shadows on the reproduced
10 image.

Module 400 enters at step 402 which asks
whether the final densities of the cyan, magenta, and
yellow are all greater than .6. If no, indicating
that this particular pixel is not densely colored,
15 black enhancement is not appropriate and the program
moves to step 404 to set the black enhancement level
KE essentially at zero or as in the preferred case at
a very low level as indicated.

20 The selection of the factor .6 in step 402
is a matter of design choice as to what level the
operator wishes black enhancement to start.

If the answer in step 402 is yes, the pro-
gram moves to step 406 which asks whether the ratio
between the final yellow density and the final magenta
25 density is between .6 and 1.4. If the answer is no,
indicating that the yellow density is low as compared
to the magenta density, the program moves to step 404.
If the answer in step 406 is yes, the program moves to
step 408 which asks whether the ratio between the
30 final magenta density and the final cyan density is
between .7 and 1.5. As those skilled in the art will
appreciate, the selection of the ranges for steps 406
and 408 is a matter of design choice. If the answer
in step 408 is no, the program moves to step 404.
35

If the answer in step 408 is yes, the pro-
gram moves to step 410 to calculate the amount of

-28-

1 enhancement black KE according to the formula shown.
This formula sets upper and lower limits on the amount
of enhancement black. These limits can be modified as
a matter of design choice. After steps 410 or 404,
5 the program loops back to step 395 (Fig. 3D).

Fig. 5 illustrates GRAY COMPONENT REMOVAL
module 500. As those skilled in the art will under-
stand, typical black process coloring agents can be
thought of as being composed of cyan, magenta and
10 yellow. Thus, black can be substituted for respective
portions of the cyan, magenta, and yellow coloring
agents which may be desirable as a cost reduction
technique since black coloring agents typically cost
less. These replaced portions of cyan, magenta, and
15 yellow together represent a gray component which is
removed and replaced by the black.

The program enters module 500 at step 502
which sets the variable "U" equal to the smallest of
the CMY final densities. Since black can substitute
for CMY, the smallest of the three represents the
20 maximum level of black to used to replace the under-
lying cyan, magenta, and yellow.

The program then moves to step 504 which
asks whether U is less than .03. If yes, indicating
that the level of black is too small to be effective,
25 the program moves to step 504 to set U equal to zero
or an extremely low number as illustrated. If the
answer in step 504 is no, the program moves to step
508 to set the variables undercolor cyan (UC), under-
color yellow (UY), and undercolor magenta (UM) equal
30 to respective factors CK, MK and YK times "U".

With many black coloring agents, the black
is balanced, that is, includes substantially equal CMY
densities. If not, as with MATCH PRINT black, the
imbalance needs to be taken into account when calcu-
35

-29-

1 relating the gray component portions of the final densi-
ties. For example, if the black coloring agent pre-
sents relative densities of 92% cyan, 100% magenta,
5 and 96% yellow, then it is not effective for replacing
all of the gray component cyan and yellow. Accord-
ingly, the relative portions of CMY are defined as re-
spective factors CK (.92), MK (1.0), and YK (.96).
These are multiplied by "U" for the undercolor cyan
(UC), magenta (UM), and yellow (UY).

10 The linearity failures as discussed above
also come into play with black. Accordingly, for
precise color correction using black, the program
takes the linearity failures into account. After step
508, the program moves to step 510 to retrieve the
15 contribution factors of the respective CMY steps
having densities nearest the densities of UC, UM, and
UY. The program then moves to step 512 to calculate
the contribution amounts as indicated for the gray
component densities of cyan, magenta, and yellow.
This step is necessary because the densities do not
20 vary linearly and so a mere substitution of black for
corresponding densities of cyan, magenta, and yellow
is not accurate. The calculations in step 512 are
similar to those in steps 316 (Fig. 3A). The correc-
tion factors a, b, d, e, f, and g are preferably the
25 same values as those in step 316 and are specific to
the coloring agents being used.

The program then moves to step 514 to calcu-
late the final densities present in the black accord-
ing to the formula as shown which are analogous to the
30 formulas in steps 340 (Fig. 3B), 366 (Fig. 3C), and
392 (Fig. 3D).

The program then moves to step 516 to calcu-
late the densities of the CMY coloring agents after
gray component removal according to the formulas as

35

-30-

1 shown. That is to say, step 516 calculates the new
final densities for cyan, magenta, and yellow repre-
sented by CFU, MFU, and YFU respectively after the
gray component portion has been removed. Step 516
5 also sets the black density KU equal to variable "U".

As discussed above, if the black coloring
agent is not balanced, it is not totally effective for
replacing all of the gray component portions of CMY.
As a result, residual amounts must be added back in
step 516 as residual cyan $[(1.0 - CK) \cdot U]$, residual
10 magenta $[(1.0 - MK) \cdot U]$, and residual yellow $[(1.0 -$
YK) $\cdot U]$.

After step 516 or 506, the program loops
back to steps 395 (Fig. 3D).

15 In use, the final color densities of the
agent colors of cyan, magenta, and yellow as repre-
sented by the output signal may be converted to a form
suitable for use by the particular reproduction unit
20 such as percentage dot sizes in increments of 1%
from zero to 100. For example, the lowest coverage
density of a coloring agent might be expressed as a 0%
dot and the maximum single impression density as a
100% dot. As used herein, the term color density
refers to density as typically measured by a densito-
meter to express cyan color density, for example, and
25 the term "coverage density" refers to the coverage of
a given image unit per unit area by the coloring
agent. Those skilled in the art will appreciate that
the coverage density can be expressed in other units
and can be expressed in fewer or greater increments.
30 It is preferred that reproduction unit 20 produce an
image with a resolution of at least 150 image units
per inch such as 150 halftone lines per inch.

The output signals are useful in the context
of a film recorder. In such an application, the RGB

35

-31-

1 data corresponding to the final CMY color densities
are represented by the output signals as retrieved
from the RGB arrays. Using a film recorder, a con-
tinuous tone negative can be produced using the output
5 signals which represent the cyan separation. Simi-
larly, continuous tone negatives can be produced from
the magenta and yellow output signals representing the
magenta and yellow separations respectively. The
negatives are then enlarged or reduced on an enlarger
10 to produce halftone line screens to produce respective
halftone positives from which respective cyan,
magenta, and yellow plates are produced for three
color printing (and a black plate if four color is
used). Such use simplifies the entire lithographic
15 process and eliminates the need for more expensive
machines as those skilled in the art will appreciate.
A film recorder can be set up to produce variable dot
sizes so that the line screen is generated directly
from the film recorder. Film recorder technology also
lends itself to laser use for a finer, sharper dot.

20 As those skilled in the art will appreciate,
the components of apparatus 10 can be incorporated
into a single unit as part of a color xerographic
copier. In such a configuration, it is preferred that
the data specific to the toners used in the copier
25 would be stored in a replaceable ROM such that if a
different type of toner is used, a replacement plug-in
ROM module containing the program can be conveniently
substituted to provide the new data for use in the
color correction calculations. As explained above,
30 the data specific to the coloring agent includes the
RGB arrays with the corresponding CMY densities, the
contribution factors, the correction factors, and the
multiplication and addition factors discussed in con-
nection with Figs. 3B-D. Additionally, this data

35

1 includes data for a black toner if a four color process is used as discussed in connection with Figs. 4 and 5.

5 The present invention contemplates many variations in the preferred embodiments described herein. For example, the preferred computer program can be implemented in a variety of different types of computers other than the preferred microcomputer 12 such that any processing unit adequate to conduct the steps of the program would be acceptable. Additionally, as those skilled in that art will appreciate, all of the logic functions illustrated in the program steps of Figs. 2-5 could be implemented by dedicated hardware such as a custom-made semiconductor chip. That is to say, rather than implementing the method of the present invention in terms of software, a custom chip incorporating the appropriate gates, shift registers, counters, and so forth could be used although such is not preferred because of the relative difficulty and expense of making changes and modifications in the operating steps.

15
20 ~~Having thus described the preferred embodiment of the present invention, the following is claimed as new and desired to be secured by Letters Patent:~~

25

30

35



The claims defining the invention are as follows

5 1. A method of operating a processing unit for producing output signals representative of agent color densities of coloring agents such as process inks or toners, to be used in producing a color-corrected image unit of an initial image unit using the coloring agents, the processing unit including memory means for storing selected data, the coloring agents presenting respective agent colors, said method comprising the steps of:

- 10 (a) entering input signals into the processing unit which are respectively representative of color readings of the image unit to be finally produced using said coloring agents;
- (b) determining initial color densities that correspond relatively to said color readings entered into the processing units;
- 15 (c) retrieving from the memory means previously stored data representative of respective contribution factors corresponding to the contribution to each of the agent colors from each of the other coloring agents;
- (d) retrieving from the memory means previously stored data representative of certain predetermined nonlinearity correction factors which are representative of the particular coloring agents to be used in producing said image unit;
- 20 (e) calculating in said processing unit, for each agent color of a respective coloring agent, a contribution amount to each of the other agent colors as a function of the effect thereon
- 25 of the respective initial color density, contribution factor, and correction factor;

SUBSTITUTE SHEET
IPEA/US

~~SUBSTITUTE SHEET
IPEA/US~~



- (f) calculating in said processing unit, for each agent color, a final agent color density as a function of its corresponding initial density and the contribution amounts from the other coloring agents; and
- 5 (g) producing output signals representative of each of said final agent color densities.

2. The method as set forth in claim 1, further including the step of repeating steps (a) through (g) for each of the image units.

10

3. The method as set forth in claim 1, step (a) including the step of entering said input signals from a scanner.

4. The method as set forth in claim 1, the processing unit including a microcomputer.

15

5. The method as set forth in claim 1, said final color agent densities corresponding to halftone dot sizes of respective coloring agents.

20

6. The method as set forth in claim 5 further including the step of receiving said output signals in a reproduction unit having means for producing representative halftone dot sizes of the respective coloring agents corresponding to said output signals.

25

SUBSTITUTE SHEET
IPEA/US

~~SUBSTITUTE SHEET
IPEA/US~~

MKS

7. The method as set forth in claim 1, further including after step (e) the step of recalculating certain ones of said contribution amounts when the contribution to a given color from at least one of the other coloring agents exceeds a predetermined level.

5

8. The method as set forth in claim 1, further including after step (f) the steps of calculating the amount of gray component removal color to be used in place of predetermined portions of said final agent color densities, and

10

reducing said final agent color densities in correspondence with the density of said gray component color.

9. The method as set forth in claim 1, further including after step (f) the step of calculating an enhancement color density as a function of said final agent color densities.

15

10. The method as set forth in claim 1, said agent colors including cyan, magenta, and yellow and said color readings including red, green, and blue.

20

SUBSTITUTE SHEET
IPEA/US

~~SUBSTITUTE SHEET
IPEA/US~~



11. An apparatus for producing output signals representative of the agent color densities of coloring agents such as process inks or toners, to be used in producing a color-corrected image unit of an initial image unit using the coloring agents, said apparatus comprising:

5 a processing unit, having memory means for storing selected data therein, for receiving input signals and for producing output signals in response thereto;

10 means for entering input signals into the processing unit which are respectively representative of color readings of the image to be finally produced using the coloring agents;

said processing unit including --

15 means for determining initial agent color densities that correspond relatively to said color readings entered into said processing unit,

20 means for retrieving from said memory means previously stored data representative of respective contribution factors corresponding to the contribution to each of the agent colors from each of the other coloring agents,

25 means for retrieving from the memory means previously stored data representative of certain predetermined nonlinearity correction factors which are representative of the particular coloring agents to be used in producing said image unit,

means for calculating, for each agent color of a respective coloring agent, a contribution amount to

SUBSTITUTE SHEET
IPEA/US

~~SUBSTITUTE SHEET
IPEA/US~~



each of the other coloring agents as a function of the effect thereon of the respective initial color density, contribution factor, and correction factor;

5 means for calculating, for each agent color, a final agent color density as a function of its corresponding initial density and the contribution amounts from the other coloring agents, and

10 means for producing output signals representative of each of said final agent color densities.

12. The apparatus as set forth in claim 11, said means for entering input signals including a scanner.

15 13. The apparatus as set forth in claim 11, said processing unit including a microcomputer.

14. The apparatus as set forth in claim 11, the reproduction unit including a film recorder.

20 15. The apparatus as set forth in claim 11, the reproduction unit including a laser printer.

~~SUBSTITUTE SHEET
IPEA/US
SUBSTITUTE SHEET
IPEA/US~~

MVS

16. The apparatus as set forth in claim 11, the reproduction unit including a xerographic color copier.

17. The apparatus as set forth in claim 11, the reproduction unit including a thermal transfer printer.

5 18. The apparatus as set forth in claim 11, the reproduction unit including an ink jet printer.

19. A method of operating a processing unit according to claim 1 substantially as hereinbefore described with reference to the accompanying drawings.

10 20. An apparatus for producing output signals according to claim 11 substantially as hereinbefore described with reference to the accompanying drawings.

Dated: 30 August 1991

15 PHILLIPS ORMONDE & FITZPATRICK

Attorneys for:

F & S CORPORATION OF COLUMBUS, GEORGIA

David B Fitzpatrick

20

25

30

35

39

MTS

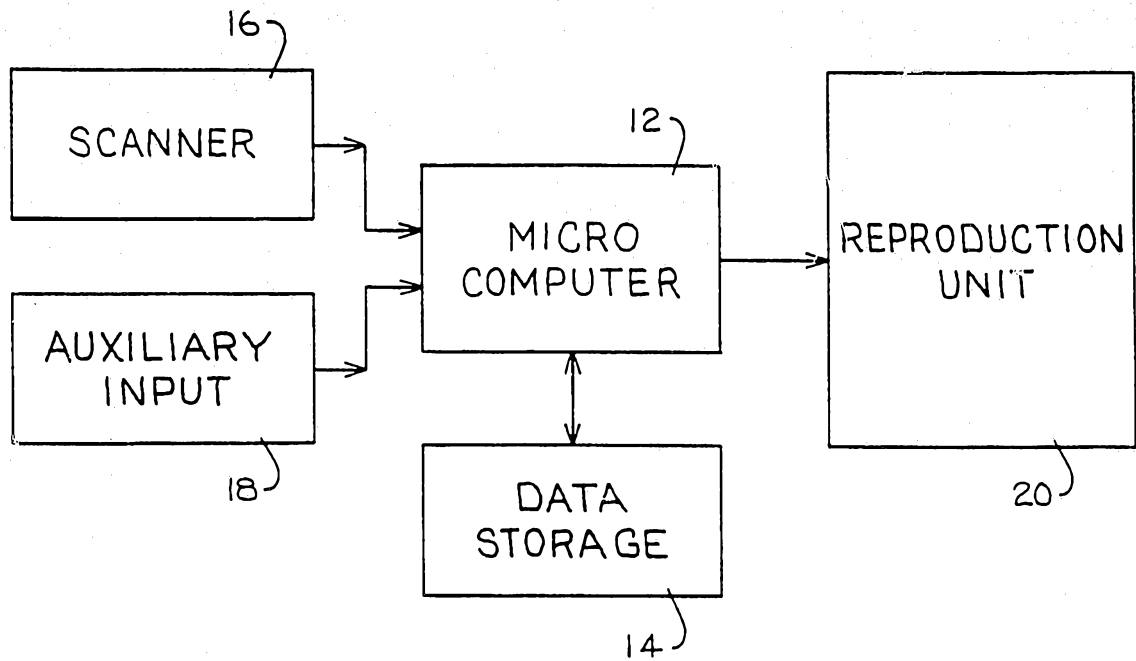

FIG. 1.

10

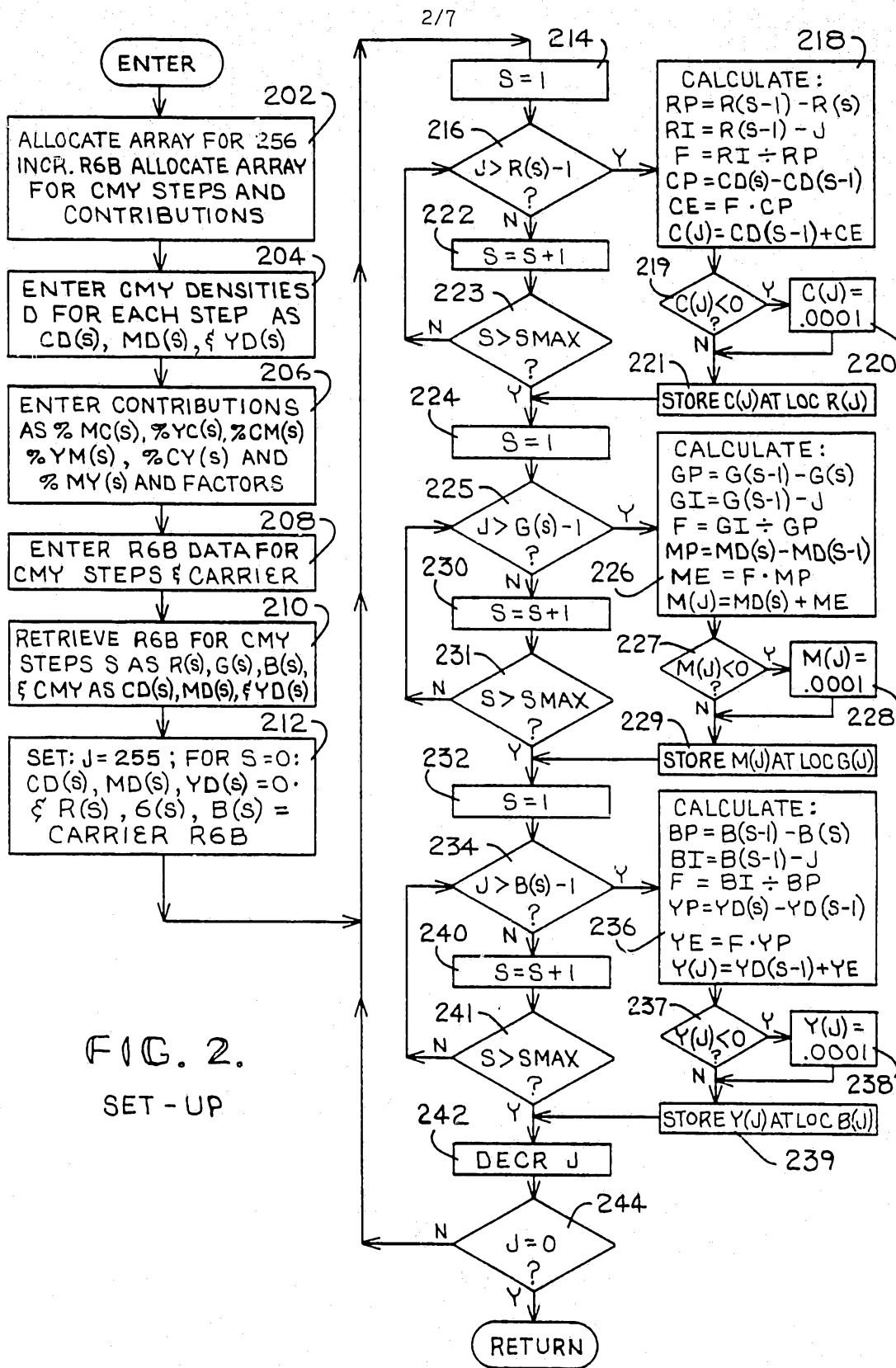

FIG. 2.
SET-UP

FIG. 3A.
COLOR
CORRECTION

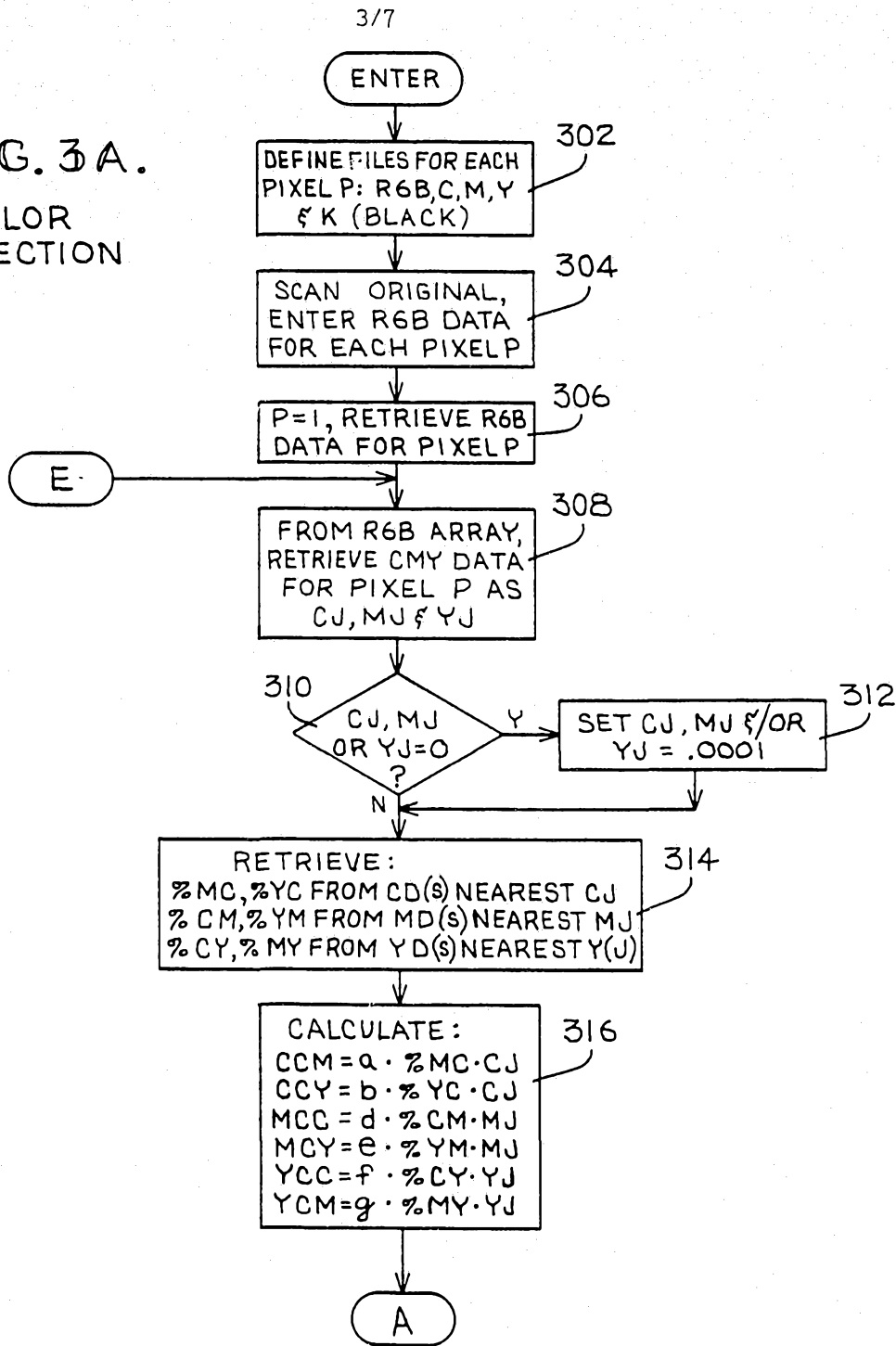

FIG. 3B.
CYAN
CORRECTION

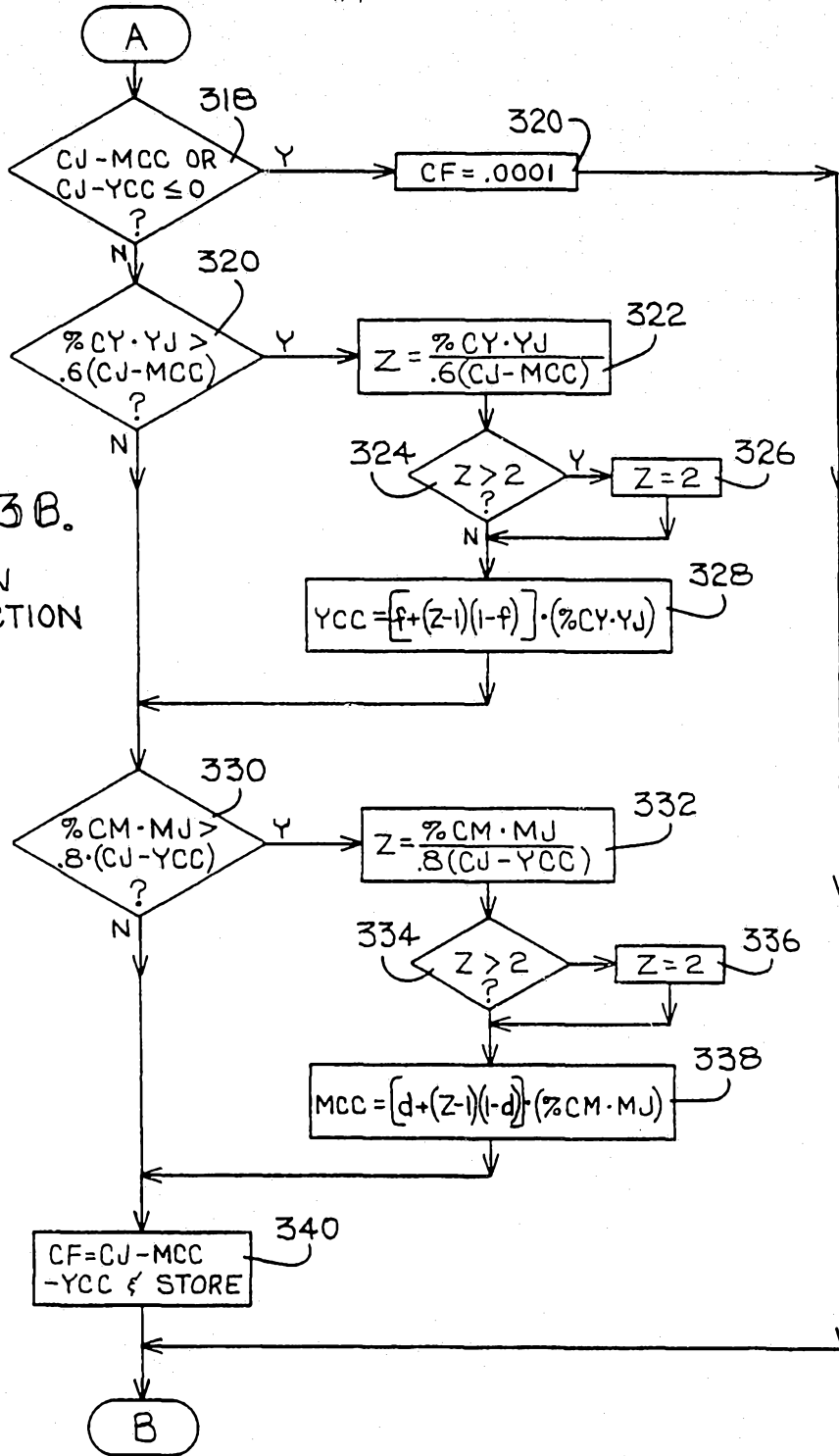

FIG. 3C.
MAGENTA
CORRECTION

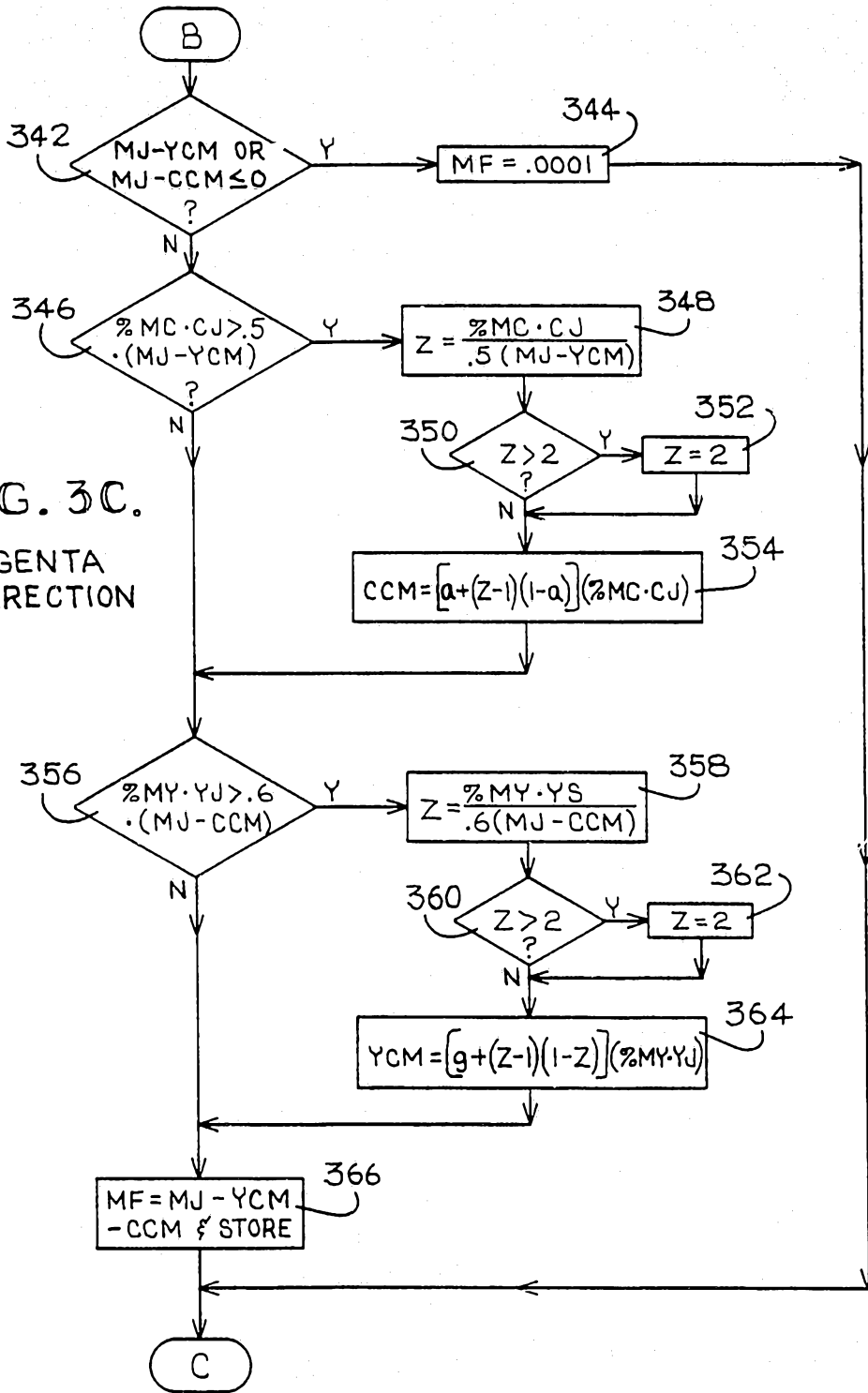
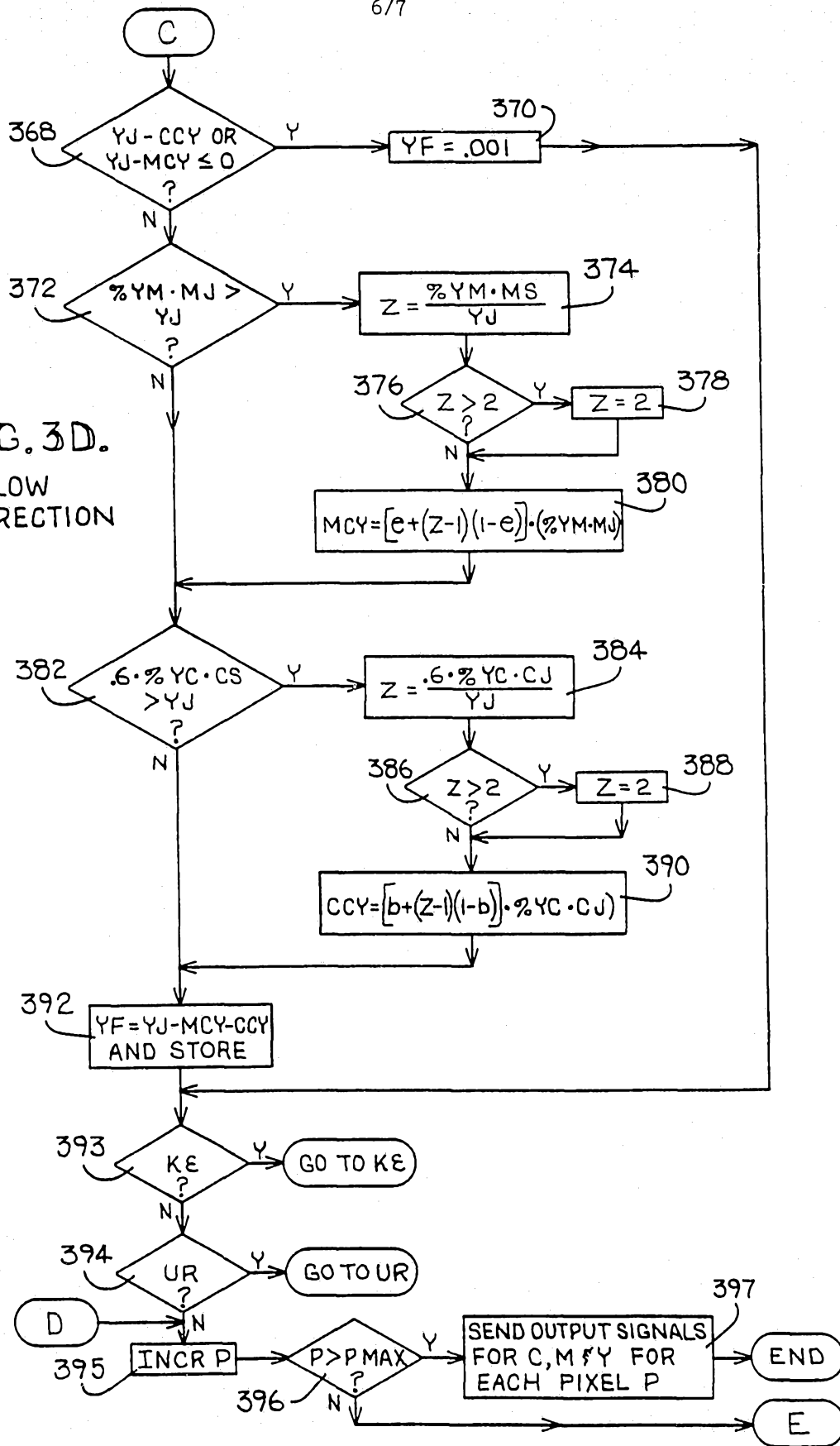

FIG. 3D.
YELLOW
CORRECTION



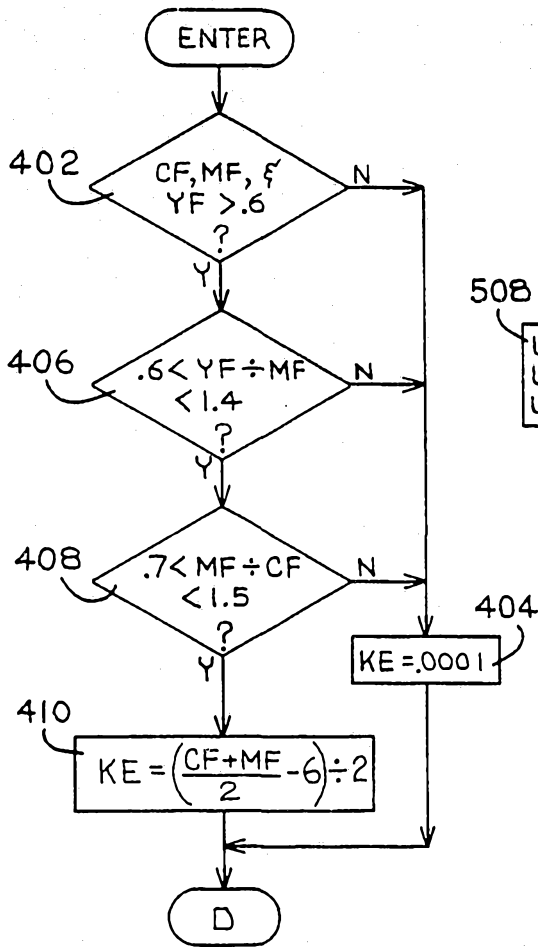

FIG. 4.
BLACK
ENHANCEMENT

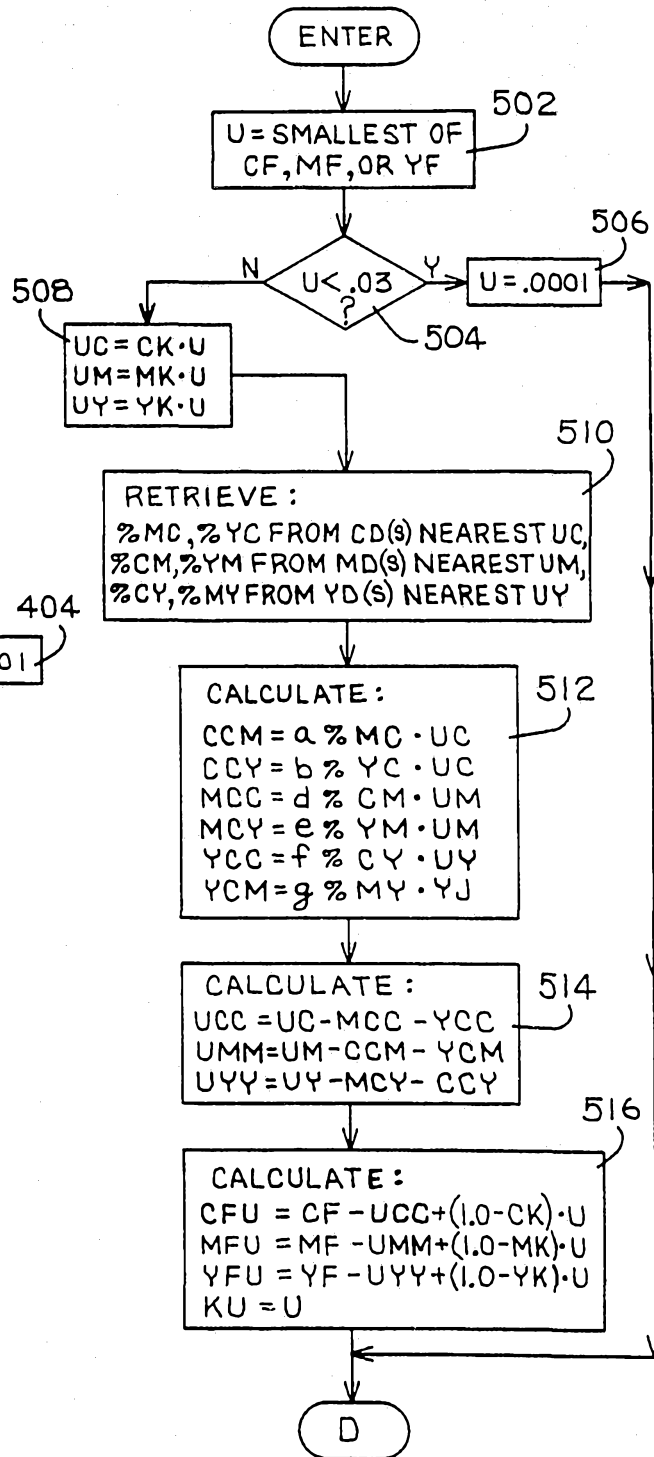

FIG. 5.
GRAY COMPONENT
REMOVAL

INTERNATIONAL SEARCH REPORT

International Application No. PCT/US89/02839

I. CLASSIFICATION OF SUBJECT MATTER (if several classification symbols apply, indicate all) ⁶		
According to International Patent Classification (IPC) or to both National Classification and IPC		
I.P.C.(4): G03F 3/10		
U.S. CL. 364/518; 358/75, 80		
II. FIELDS SEARCHED		
Minimum Documentation Searched ⁷		
Classification System	Classification Symbols	
U.S.	364/518, 519, 521, 526 358/75, 80	
Documentation Searched other than Minimum Documentation to the Extent that such Documents are Included in the Fields Searched ⁸		
III. DOCUMENTS CONSIDERED TO BE RELEVANT ⁹		
Category *	Citation of Document, ¹¹ with indication, where appropriate, of the relevant passages ¹²	Relevant to Claim No. ¹³
Y	US, A, 4,468,692 (YAMADA ET AL.) 28 AUGUST 1984, See the entire document.	1-18
Y	US, A, 4,482,917 (GAULKE ET AL.) 13 NOVEMBER 1984, See column 2, lines 24 to 34.	3 and 12
A,P	US, A, 4,819,193 (IMAO) 04 APRIL 1989, See the summary	1-18
A	US, A, 4,683,492 (SUGIURA ET AL.) 28 JULY 1987, See the summary.	1-18
A	US, A, 4,680,596 (LOGAN) 14 JULY 1987, See the summary.	1-18
A	US, A, 4,639,770 (JUNG ET AL.) 27 JANUARY 1987, See the summary	1-18
A	US, A, 4,564,859 (KNOP ET AL.) 14 JANUARY 1986, See the Abstract.	1-18
A,	US, A, 4,060,829 (SAKAMOTO) 29 NOVEMBER 1977, See the Abstract.	1-18
<p>* Special categories of cited documents: ¹⁰</p> <p>"A" document defining the general state of the art which is not considered to be of particular relevance</p> <p>"E" earlier document but published on or after the international filing date</p> <p>"L" document which may throw doubts on priority claim(s) or which is cited to establish the publication date of another citation or other special reason (as specified)</p> <p>"O" document referring to an oral disclosure, use, exhibition or other means</p> <p>"P" document published prior to the international filing date but later than the priority date claimed</p> <p>"T" later document published after the international filing date or priority date and not in conflict with the application but cited to understand the principle or theory underlying the invention</p> <p>"X" document of particular relevance; the claimed invention cannot be considered novel or cannot be considered to involve an inventive step</p> <p>"Y" document of particular relevance; the claimed invention cannot be considered to involve an inventive step when the document is combined with one or more other such documents, such combination being obvious to a person skilled in the art.</p> <p>"&" document member of the same patent family</p>		
IV. CERTIFICATION		
Date of the Actual Completion of the International Search		Date of Mailing of this International Search Report
31 JULY 1989		05 SEP 1989
International Searching Authority		Signature of Authorized Officer
ISA/US		<i>Michael Jaffe</i> MICHAEL JAFFE