

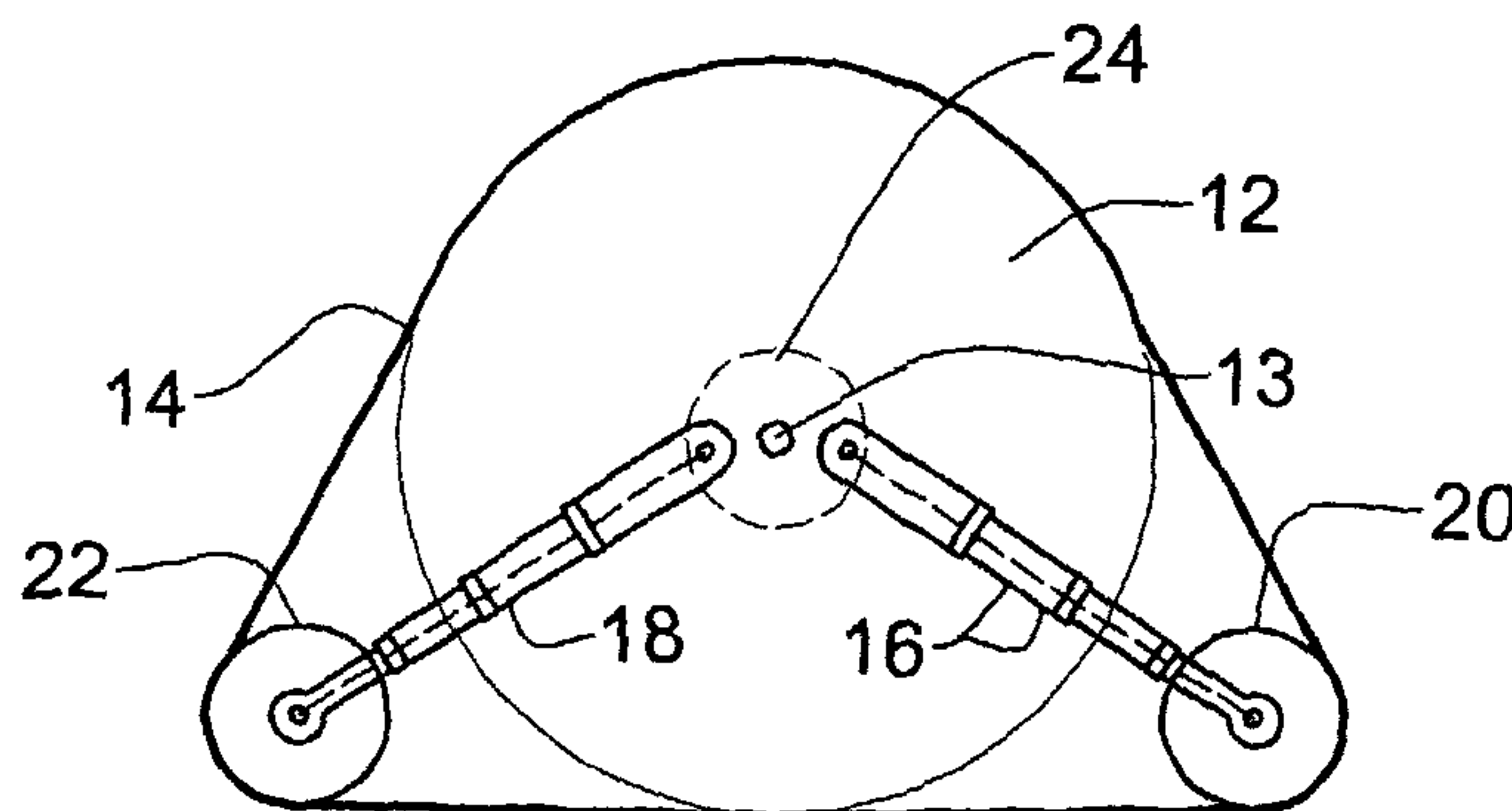

(86) Date de dépôt PCT/PCT Filing Date: 2002/10/03
 (87) Date publication PCT/PCT Publication Date: 2003/04/10
 (85) Entrée phase nationale/National Entry: 2004/03/30
 (86) N° demande PCT/PCT Application No.: IL 2002/000807
 (87) N° publication PCT/PCT Publication No.: 2003/029070
 (30) Priorité/Priority: 2001/10/03 (60/326,430) US

(51) Cl.Int.⁷/Int.Cl.⁷ B62D 55/075, B62D 55/30, B62D 55/24,
B60B 19/04, B62D 55/00
 (71) Demandeur/Applicant:
GALILEO MOBILITY INSTRUMENTS LTD., IL
 (72) Inventeurs/Inventors:
SPECTOR, YUVAL, IL;
RAZ, DAN, IL;
NOVOPLANSKI, AVISHAY, IL;
RINBERG, GREGORY, IL
 (74) Agent: BORDEN LADNER GERVAIS LLP

(54) Titre : SYSTEME DE TRACTION ADAPTABLE D'UN VEHICULE
 (54) Title: ADAPTABLE TRACTION SYSTEM OF A VEHICLE



(57) **Abrégé/Abstract:**

A traction system for a vehicle has a support frame that defines a circular track belt support that is revolvable about an axis at its center, a flexible track belt; and a track belt stretching assembly comprising one or more track belt stretching rollers. The system has one traction configuration in which the flexible traction belt is held on said support track forming a substantially circular, wheel-like traction surface, and can change to a stretching state in which said rollers engage said belt and stretch it from its state in said one traction configuration to a stretched state to define one or more other traction configurations of the system.

(12) INTERNATIONAL APPLICATION PUBLISHED UNDER THE PATENT COOPERATION TREATY (PCT)

(19) World Intellectual Property Organization
International Bureau(43) International Publication Date
10 April 2003 (10.04.2003)

PCT

(10) International Publication Number
WO 03/029070 A1(51) International Patent Classification⁷: **B62D 55/075**, (74) Agent: **REINHOLD COHN AND PARTNERS**; P.O.Box 4060, 61040 Tel Aviv (IL).
55/24, 55/24, 55/30, 55/00, B60B 19/04(21) International Application Number: PCT/IL02/00807 (81) Designated States (*national*): AE, AG, AL, AM, AT, AU, AZ, BA, BB, BG, BR, BY, BZ, CA, CH, CN, CO, CR, CU, CZ, DE, DK, DM, DZ, EC, EE, ES, FI, GB, GD, GE, GH, GM, HR, HU, ID, IL, IN, IS, JP, KE, KG, KP, KR, KZ, LC, LK, LR, LS, LT, LU, LV, MA, MD, MG, MK, MN, MW, MX, MZ, NO, NZ, OM, PH, PL, PT, RO, RU, SD, SE, SG, SI, SK, SL, TJ, TM, TN, TR, TT, TZ, UA, UG, US, UZ, VC, VN, YU, ZA, ZM, ZW.

(22) International Filing Date: 3 October 2002 (03.10.2002)

(25) Filing Language: English

(26) Publication Language: English

(30) Priority Data:
60/326,430 3 October 2001 (03.10.2001) US(71) Applicant (*for all designated States except US*):
GALILEO MOBILITY INSTRUMENTS LTD. [IL/IL];
Meshek 60, 73150 Moshav Kfar Truman (IL).

(72) Inventors; and

(75) Inventors/Applicants (*for US only*): **SPECTOR, Yuval** [IL/IL]; Hatamid Street 14, 52501 Ramat Gan (IL). **RAZ, Dan** [IL/IL]; Bchorim Street 62, 34577 Haifa (IL). **NOVO-PLANSKI, Avishay** [IL/IL]; Moshav Beit Zeit, 90815 Moshav Beit Zeit (IL). **RINBERG, Gregory** [IL/IL]; Haprachim Street 73/1, 34863 Haifa (IL).**Published:**— *with international search report**For two-letter codes and other abbreviations, refer to the "Guidance Notes on Codes and Abbreviations" appearing at the beginning of each regular issue of the PCT Gazette.*

(54) Title: ADAPTABLE TRACTION SYSTEM OF A VEHICLE

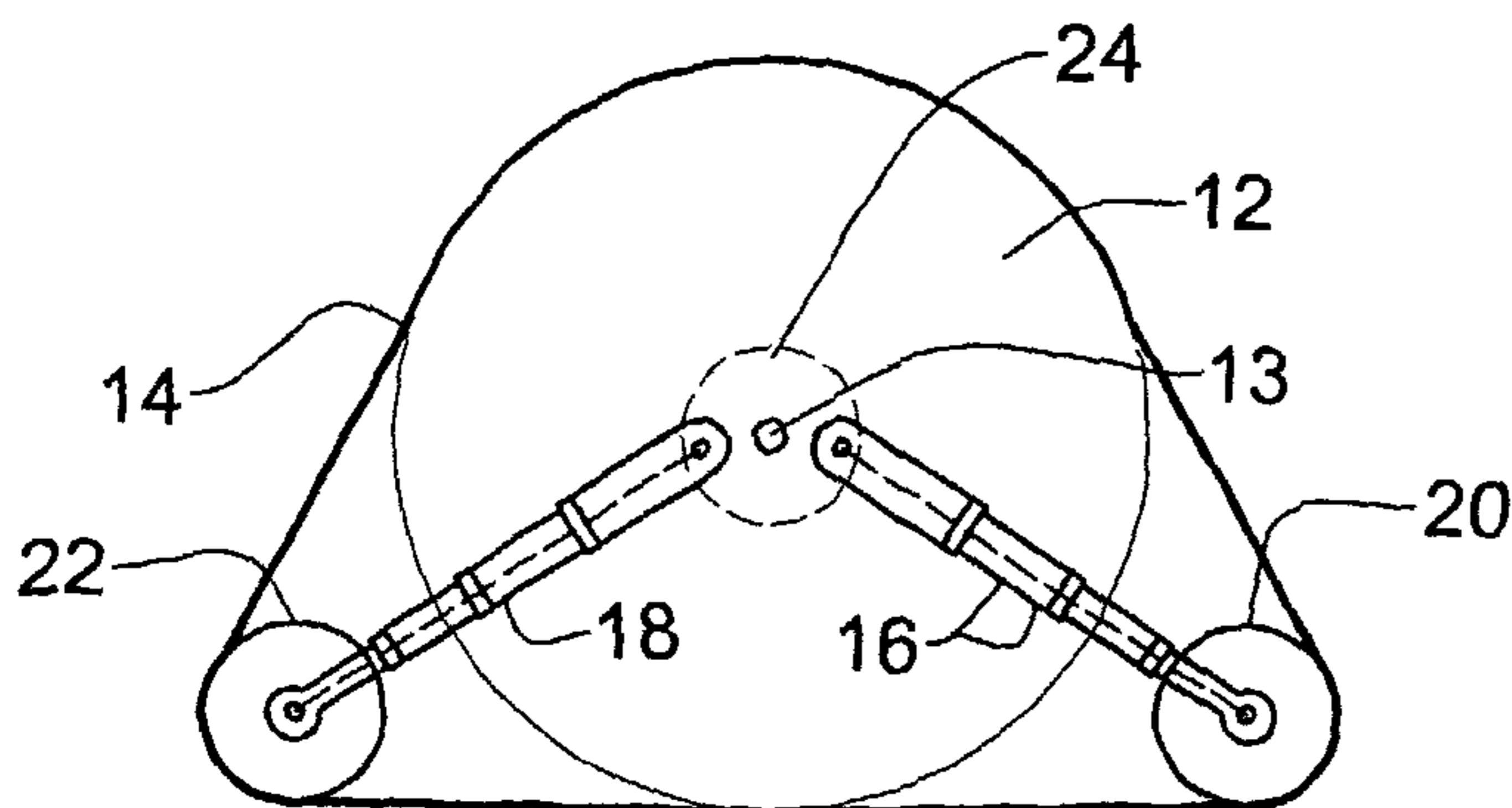

(57) Abstract: A traction system for a vehicle has a support frame that defines a circular track belt support that is revolvable about an axis at its center, a flexible track belt; and a track belt stretching assembly comprising one or more track belt stretching rollers. The system has one traction configuration in which the flexible traction belt is held on said support track forming a substantially circular, wheel-like traction surface, and can change to a stretching state in which said rollers engage said belt and stretch it from its state in said one traction configuration to a stretched state to define one or more other traction configurations of the system.



WO 03/029070 A1

ADAPTABLE TRACTION SYSTEM OF A VEHICLE

FIELD OF THE INVENTION

The invention relates to traction systems. More specifically the invention is in the field of personal carriage of disabled persons.

BACKGROUND OF THE INVENTION

5 Versatile traction systems that permit movement on various different terrains are required for a number of different purposes. A particular example is a wheelchair. In most wheelchairs the traction system consists of wheels (typically one main, large wheel and one auxiliary, small wheel on each side) and it permits to move the wheelchair over smooth horizontal surfaces of such floors or pavements.
10 These traction systems are not suitable for passing obstacles such as steps and others, moving through staircases or moving over rough terrains. A versatile traction system has been described in PCT Publication WO 99/21740. In the system described in this publication, means are provided that can change at will the traction configuration for the purpose of increasing the trafficability and safety. A
15 preferred use of the system described in this PCT publication is wheelchairs.

SUMMARY OF THE INVENTION

In accordance with the invention a new traction system for a vehicle is provided. The term "*vehicle*" usually refers to a platform that moves over a terrain through wheels or track. This includes self-powered vehicles, for example a sport
20 utility vehicle (SUV) or a carriage without self-powering means. A wheelchair is one specific embodiment of the vehicle in accordance with the invention. As will be appreciated from the disclosure below, the traction system provided by the

- 2 -

invention is suitable for a wide variety of vehicles such intended for travelling over different terrains.

The traction system provided by the invention is versatile in that it has a variety of different configurations. It has one configuration particularly suitable for travelling over a relatively smooth terrain, for example, in the case of a wheelchair over floors, pavements or roads. Other configurations are suitable for travelling over difficult terrains, for example, rough surfaces, e.g. a non-paved road, and obstacles. In the case of a wheelchair, for example, the traction system permits the wheelchair to ascend or descend through staircases.

10 In accordance with the invention, a traction system is provided which utilizes auxiliary rollers that can stretch a flexible traction belt from a substantially circular configuration, into which the traction belt is naturally biased, into other traction configurations, as will be described below.

By a first aspect of the invention there is provided a traction system for a vehicle that comprises:

- a support frame defining a circular track belt support that is revolvable about an axis at its center, said axis being in a fixed position with respect to a chassis of the vehicle;
- a flexible track belt; and
- 20 - a track belt stretching assembly comprising one or more track belt stretching rollers;

said system having one traction configuration in which the flexible traction belt is held on said support track forming a substantially circular, wheel-like traction surface, said belt stretching assembly can change to a stretching state in which said rollers engage said belt and stretch it from its state in said one traction configuration to a stretched state to define one or more other traction configurations of the system.

Also provided by the invention, according to another of its aspects, is a vehicle comprising one or more, typically two, traction systems of the first aspect. One example of a vehicle in accordance with this aspect, is a wheelchair.

30

- 3 -

In accordance with one embodiment, the rollers of the traction system, typically small wheels, are held on distal ends of belt extension arms respectively, that are in turn attached at their proximal ends, typically in a pivotal manner, to the vehicle's chassis.

5 In accordance with another embodiment of the invention, the revolvable support frame comprises two coaxial support members with a gap between them, that together define said circular track belt support. The void space that extends radially from the axis to the lateral part of the gap defines a belt-stretching assembly-holding space and in said one traction configuration, the belt-stretching
10 assembly is housed within said space.

In the latter embodiment, the belt has preferably a central projection or series of projections that extend into the gap securing the track belt from sliding off its support. The belt-extension rollers similarly consist of two cooperating coaxial wheels that have a gap between them and said projections or series of projections
15 fit into the gap when said rollers engage the track belt in said one or more other traction configurations of the system.

Also provided by another aspect of the invention is a flexible track belt for use in the above traction system.

By one embodiment of this latter aspect, a flexible track belt is provided that
20 forms a closed loop, said belt consisting of a plurality of connected belt elements each of which includes at least two stretchable components. Each of the belt elements is biased into a contracted state by said components in which all members together bias the belt to assume a circular shape. Said belt can be stretched, forming a succession of stretched states by first causing the stretching of one of the at least
25 two of said stretchable components, while the others are still relatively relaxed and gradually, with further extension, causing other of said stretchable components to stretch.

In accordance with a preferred embodiment, all of said belt members are integrally formed.

- 4 -

BRIEF DESCRIPTION OF THE DRAWINGS

In order to understand the invention and to see how it may be carried out in practice, a preferred embodiment will now be described, by way of non-limiting example only, with reference to the accompanying drawings, in which:

5 **Fig. 1A** is a schematic illustration of a side view of an embodiment of a traction system of the invention with retracted chain-stretching arms;

Fig. 1B shows the traction system of Fig. 1A, in one traction configuration with the two belt-extension arms extending beyond the wheel's parameters;

10 **Fig. 1C** shows the traction system of Fig. 1A in another traction configuration with only one of the belt-extension arms extended;

Fig. 1D shows the traction system of Fig. 1A with one of the belt-extension arms in the configuration of Fig. 1C, passing over an obstacle.

Fig. 2 is a schematic illustration of a cross-section through line II-II in Fig. 1A.

15 **Fig. 3A** is a schematic illustration of a side view of an embodiment of the invention including an angle limiter fitted on the chassis.

Fig. 3B shows the embodiment of Fig. 5A with a belt-extension abutting the angle limiter.

20 **Fig. 4A** shows one contracted configuration of a traction system in accordance with an embodiment of the invention.

Figs. 4B and **4C** are, respectively, side elevation and isometric views of the traction system of Fig. 4A with the front wheel and the flexible track belt removed for better viewing of the track belt tensioning system.

25 **Figs. 4D-4G** show a succession of different traction configurations of a traction system in accordance with another embodiment of the invention.

Fig. 5A is a schematic illustration of a portion of a flexible track belt according to an embodiment of the invention showing ring-like elements of which the belt is made.

30 **Fig. 5B** is a schematic illustration of a portion of the track belt of Fig. 5A in a stretched state.

- 5 -

Fig. 5C is a schematic illustration of a portion of a flexible track belt according to an embodiment of the invention showing elements of the kind shown in Fig. 5A with tracking soles filled thereto.

Fig. 5D is a schematic illustration of a portion of the track belt of Fig. 5D in
5 a stretched state.

Fig. 6 is a schematic illustration of a side view of a portion of stretchable belt according to another embodiment of the invention.

Fig. 7 shows a traction belt in accordance with another embodiment of the invention seen here in isolation in its circular form.

10 **Figs 8A-8D** show a longitudinal cross-section through a portion of the track belt of Fig. 7 in an initial and a succession of stretched states.

Figs 9A and **9B** show the traction system of the invention fitted onto a wheelchair, in two different traction configurations.

15 **Figs. 10A** and **10B** show the traction system of the invention fitted onto an SUV, in two different traction configurations.

Figs. 11A and **11B** show the traction system of the invention fitted onto a motor cycle, in two different traction configurations.

DETAILED DESCRIPTION OF THE INVENTION

A side view of a traction system according to an embodiment of the present
20 invention is shown in a schematic manner in Figs. 1A, 1B, 1C and 1D to which reference is now made. The traction system generally indicated by arrow 10 includes a large circular frame (to be referred to hereinbelow as "*wheel*") 12 revolvable around an axle 13. Fitted on the rim of wheel 12 is a flexible traction belt 14. Two extendible belt-stretching arms 16 and 18 are disposed behind
25 wheel 12. The extension of arms 16 and 18 in the embodiment is through a telescopic hydraulic pressure-activated elongation arrangement. Each of the stretching arms 16 and 18 is pivotally connected at its upper end by means of pivots 17 and 18, respectively to a portion 24 of a chassis of a vehicle (not shown). Each of the stretching arms 16 and 18 has a respective tension wheel 20 and 22

- 6 -

connected at its lower end. In the traction configuration seen in Fig. 1A, the traction belt **14** is tightly fitted around wheel **12** and has the wheels in a circular shape. This traction configuration is particularly suitable for moving over a smooth terrain.

In Fig. 1B the same system is shown with both stretching arms extended in length and angularly displaced one from the other, defining a traction configuration in which traction belt **14** stretches around the upper part of wheel **12** and arrow tension wheels **20** and **22**. This traction configuration, as will also be explained below, has improved maneuverability over rough terrains, such as for example, a non-paved surface, as compared to the traction configuration of Fig. 1A.

In Fig. 1C a different traction configuration is shown in which only one stretching arm **18** and the associated tension wheel **22** is extended, essentially horizontally with the wheel **22** being somewhat more elevated than in the configuration shown in Fig. 1B. In Fig. 1D the system with the same tracking configuration as in Fig. 1C is shown passing over an obstacle, such as a rock **24**, with the belt being deformed by the change in distribution of strains on traction belt **14**.

Reference is now being made to Fig. 2 giving a schematic cross-section made through lines II-II in Fig. 1. It should be noted that the relative dimensions of the various components do not actually reflect those dimensions in real life and the changes that were made were for the purpose of ease of illustration. As can be seen, the circular frame consists of wheel **12** and a corresponding coaxial wheel **12A**. A gap **30** is formed between them with the space confined between the two wheels constituting a track belt extension assembly confined to space **32**.

As can also be seen, wheel **20** has a cooperating coaxial wheel **28** with a gap formed between them as well.

Traction belt **14** is formed with a longitudinal projection or a succession of projections **34** projecting into gap **30**. Projection **34** ensures that the belt does not slip off the wheels. As can be seen both in Fig. 1A and Fig. 2, in this retracted configuration, the belt extension assembly is confined to space **32**.

- 7 -

Reference is now being made to Fig. 3A and 3B showing another embodiment of the invention, similar to that shown in Figs. 1A-1D, with the addition of an angular limiters **80** and **82** intended to limit the angular displacement of the belt stretching arms. The traction configuration in Figs. 3A and 3B correspond to those of Fig. 1A and Fig. 1B and the same reference numerals as those used in Figs. 1A and 1B used herein as well to indicate the same components.

Reference is now being made to Figs. 4A-4G showing a traction system in accordance with another embodiment of the invention in a variety of views and in different successive traction configuration.

Reference is first being made to Fig. 4A showing a traction system generally designated **100** with a traction belt support **101** that includes two cooperating and coaxial support wheels **102** with a gap between them. These two wheels **102** define between them a track belt stretching assembly confining space that houses a track belt extension assembly generally designated **104**, some components of which can be seen through the cut-out in wheel **102** and which will be explained further below. Fitted over track belt support **101** is a flexible and extendible track belt **106** that is tightly held over track belt support **101**. The entire traction system in the configuration shown in Fig. 4A revolves about a fixed axle **107** through the intermediary of bearings **108**.

Reference is now being made to Figs. 4B and 4C which are respectively side elevation and isometric view of the traction system in the configuration shown in Fig. 4A with one of wheels **102** and with the track belt removed to permit better view of the components of the track belt stretching system **104**.

Stretching system **104** includes two pairs of track belt extension wheels, including wheels **110**, and wheels **112**, revolvably attached at respective ends of arms **114** and **116**. Arms **114** and **116** are each pivotally fixed at **118** and **120**, respectively, two respect pivot members **122** and **124** that are rigidly linked to axle **107** (the link not shown for ease of illustration).

System **104** also includes two hydraulic piston members **130** and **132** pivotally anchored at **134** and **136** to a member (not shown) which is rigidly linked

- 8 -

to axle 107. In this manner arms 114 and 116 as well as piston members 130 and 132 are indirectly anchored to the chassis of the vehicle (through axle 107 which is in fact a chassis extension).

Provided on each of arms 114 and 116 are a pair of auxiliary wheels 138
5 and 140.

Piston members 130 and 132 are linked, in a pivotal manner, to levers 146 and 148 which are in turn pivotally linked at 150 and 152 to respective arms 114 and 116. Thus, by extension of the piston, arms 114 and 116 are angularly displaced in the direction of arrows 160 and 162, respectively, thereby stretching the track
10 belt as will be shown below.

System 104 also includes a spring system generally designated 170 that includes a spring member 172 that provides a biasing force for retracting the arms 114 and 116 on the one hand and provides some resilience to the arms in their stretched position on the other hand.

15 A series of successive stretched configurations of the traction system 100 can be seen in Figs. 4D-4G. In Figs. 4F and 4G, the stretchable track belt has been included for clear illustration of the function. With reference made now to Fig. 4F, it can be seen that in this configuration the track belt is stretched defining a straight ground engaging section 180. In this configuration, the vehicle is in fact supported
20 by the main wheel 102 and by the track belt tensioning wheels 110 and 112. In this configuration, auxiliary wheels 138 and 140, serve to further stabilize the track belt in its position.

In the configuration of the traction system 100 which can be seen in Fig. 4G, the track belt is fully stretched and the surface support is now only through
25 wheels 110 and 112, with the vehicle being elevated above the ground as compared to the configuration in Fig. 4F.

As can be appreciated, support 101 may be engaged rotatably to a motor in order to propel the vehicle.

Reference is now being made to Fig. 5A, which is a schematic
30 representation of a portion of a track belt 200 which includes a plurality of linked

- 9 -

ring-like elements **202**. Each of these ring-like elements which is made from a flexible thermoplastic material **204** and includes an internal reinforcement element **208**. Thus when stretched, into the position shown in Fig. 5B, through the reinforcing element **208**, the integrity of the track belt is maintained.

5 Another embodiment of a track belt **210** can be seen in Fig. 5C. Similarly as in the embodiment of Fig. 5A, the track belt includes a plurality of integral belt elements **212** linked by members **214**, which serve both for ground engagement and for structure reinforcement. When extended, members **214** maintain the track belt integrity.

10 Another embodiment of a track belt is shown schematically in Fig. 6. Here again, a portion of the belt only is seen and similarly as in the embodiment of Figs. 5A and 5C, it includes a plurality of belt elements **222** including each an elongation limiter **224**.

A portion of the track belt **240** in accordance with another embodiment of
15 the invention can be seen in Fig. 7. In accordance with this embodiment, the track belt is formed integrally from a flexible elastic material. The track belt is formed with a plurality of repeating integrally formed units **242**. Each unit **242** includes a relatively rigid surface engaging member **244**, an opposite radial projection **246** which fits into the gap formed between two pairs of wheels **242** and two pairs of
20 stretching wheels **110** and **112** (see Figs. 4A-4G). Each element includes also two linking elements including an outwardly undulated sheet **250** and oppositely a thinner and shorter sheet **252**. A third connecting element is sheet **254** that extends between adjacent projections **246**.

A side elevation of a portion of the track belt of Fig. 7 in various states
25 including a contracted state shown in Fig. 8A and a succession of stretched states shown in Figs. 8B-8D. As can be seen in Fig. 7, to which reference is again made, in the contracted state, the track belt is biased into a circular shape. Upon stretching, the first element to be stretched is connecting element **252**, with the other connecting element **250** being relatively relaxed. Upon further stretching,
30 element **250** is recruited into the stretching process.

– 10 –

In its contracted state, the track belt travels relatively smoothly over a smooth surface. In case of a rough surface, in which case the traction system is changed to the configuration of the kind shown in Fig. 4F or 4G, the flanks of members **244** can firmly engage with ground elements, obstacles, stairs, etc.

5 A wheelchair, an SUV and a motor cycle, fitted with a traction system of the invention, each, in two traction configurations, can be seen in Figs. 9A to 11B.

- 11 -

CLAIMS:

1. A traction system for a vehicle, comprising:
 - a support frame defining a substantially circular track belt support that is revolvable about an axis at its center, said axis being in a fixed position with respect to a chassis of the vehicle;
 - a flexible track belt; and
 - a track belt stretching assembly comprising one or more track belt stretching rollers;said system having one traction configuration in which the flexible traction belt is held on said support track forming a substantially circular, wheel-like traction surface, said belt stretching assembly can change to a belt stretching state in which said rollers engage said belt and stretch it out from its relatively relaxed state in said one traction configuration, to a stretched state to define one or more other traction configurations of the system.
2. A traction system according to Claim 1, wherein said rollers are held on distal ends of belt extension arms attached at their proximal end to the vehicle's chassis.
3. A traction system according to Claim 2, wherein said revolvable support frame comprises two coaxial circular cooperating support members with a gap between them defining together said circular track belt support, the void space extending radially from the axis to the lateral part of said gap defining a track belt stretching assembly-holding space, said belt-stretching assembly being housed within said space in said one traction configuration.
4. A vehicle comprising one or more traction systems according to any one of Claims 1 to 3.
5. A flexible track belt forming a closed loop, said belt consisting of a plurality of connected belt elements, each of the belt elements including at least two stretchable components; each of said members is biased into a contracted state by said components, in which all members together bias the belt to assume a circular

- 12 -

shape; said belt can be stretched into a succession of stretched states by first causing the stretching of one of the at least two of said stretchable components, while the others are still relatively relaxed and gradually with further extension causing other of said stretchable components to stretch.

- 5 6. A flexible belt according to Claim 5, wherein all members are integrally formed.
7. A flexible belt according to Claim 5 or 6, being a flexible traction belt for use in a traction system according to any one of Claims 1 to 3.
8. A flexible traction system according to Claim 7, wherein each of said belt
10 members comprises a substantially rigid surface-engaging component.

1/15

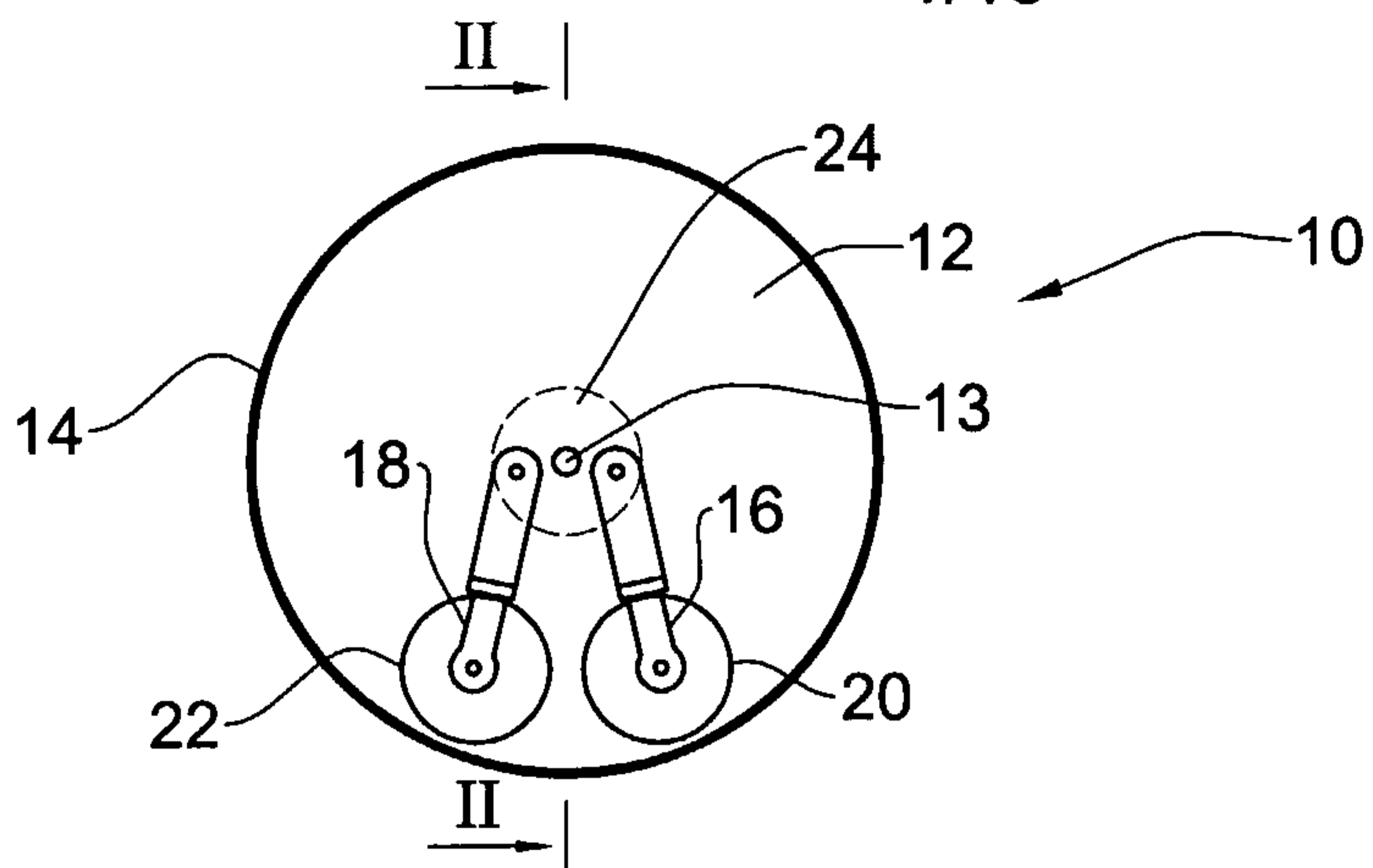

FIG. 1A

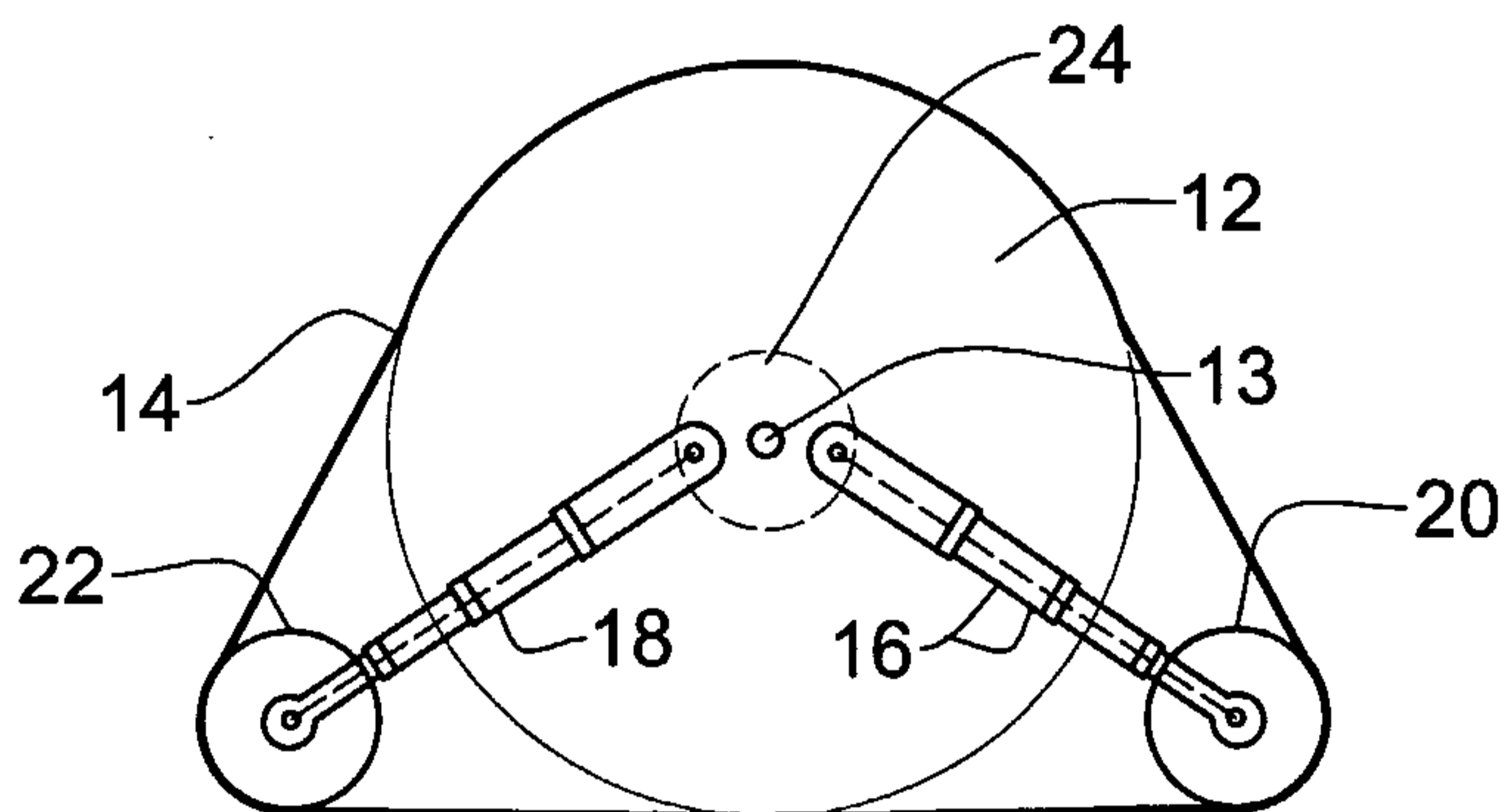

FIG. 1B

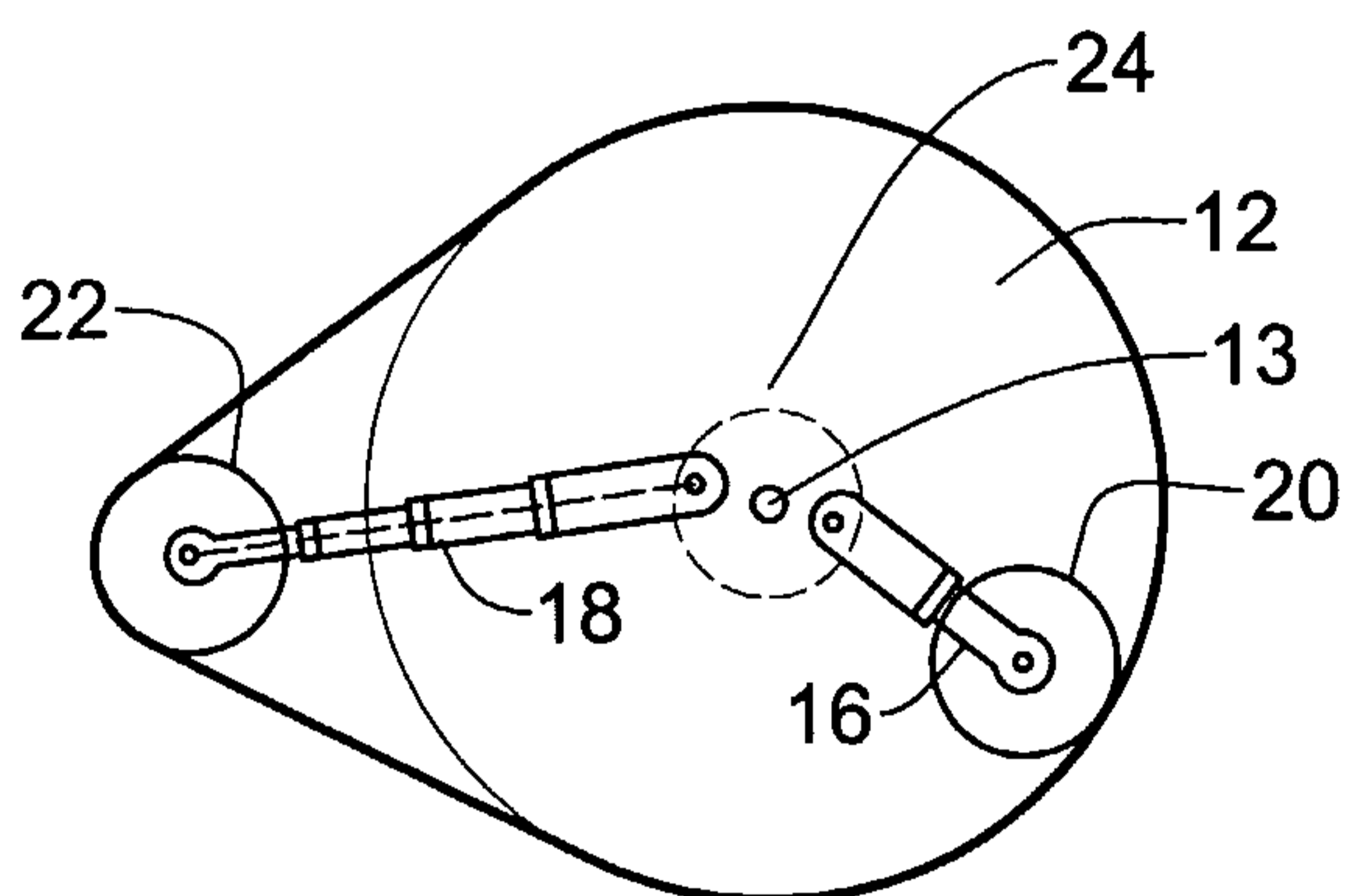

FIG. 1C

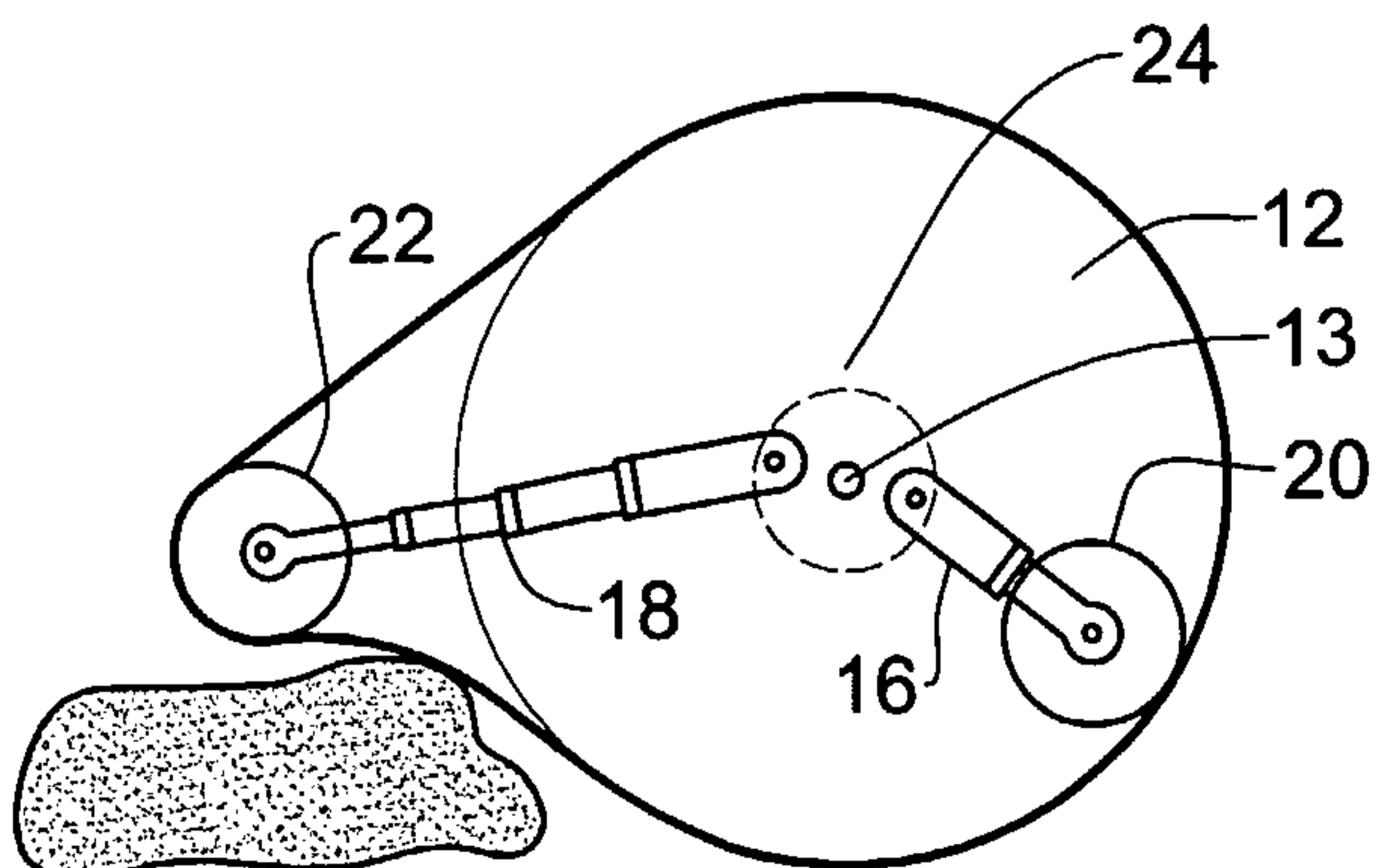

FIG. 1D

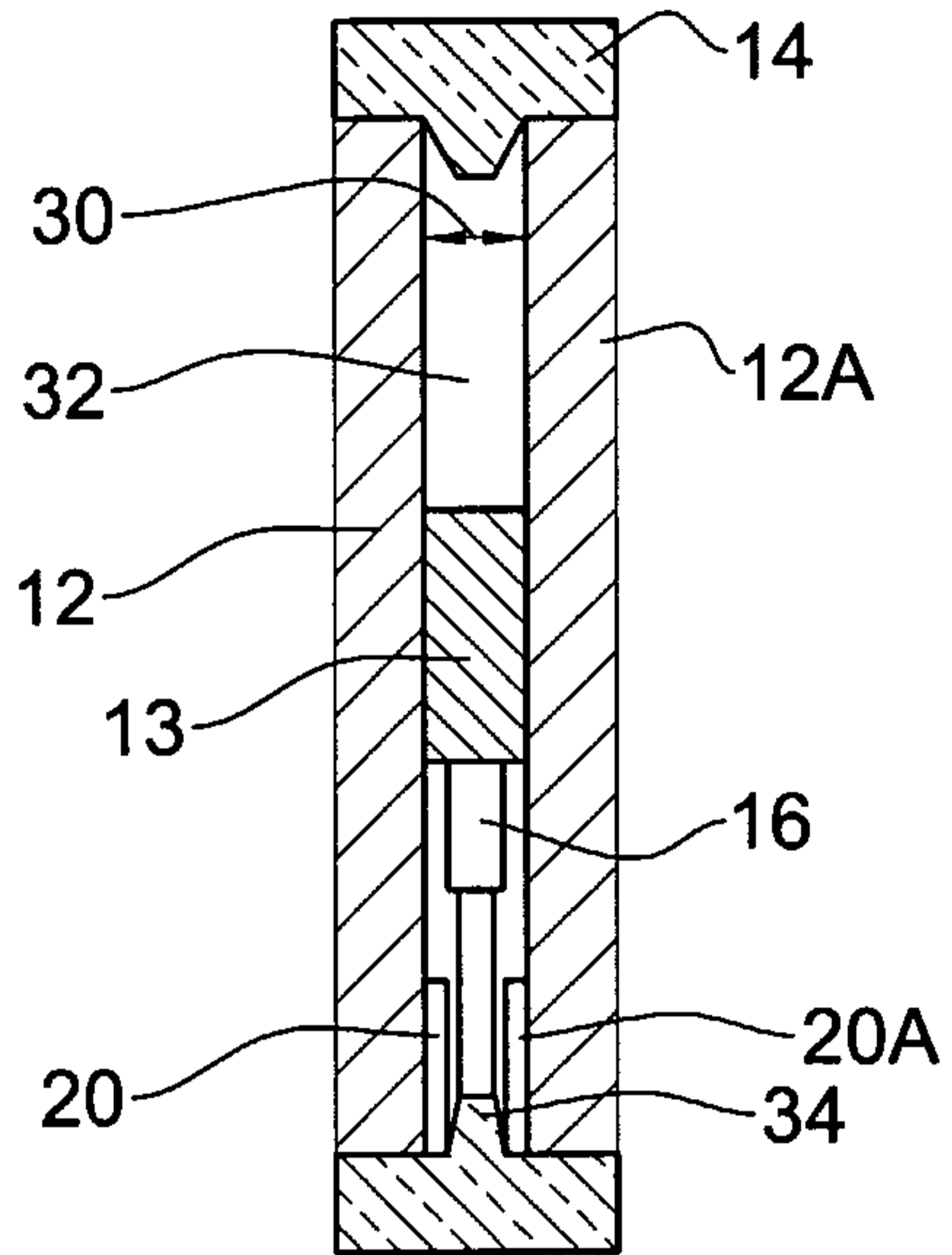

FIG. 2

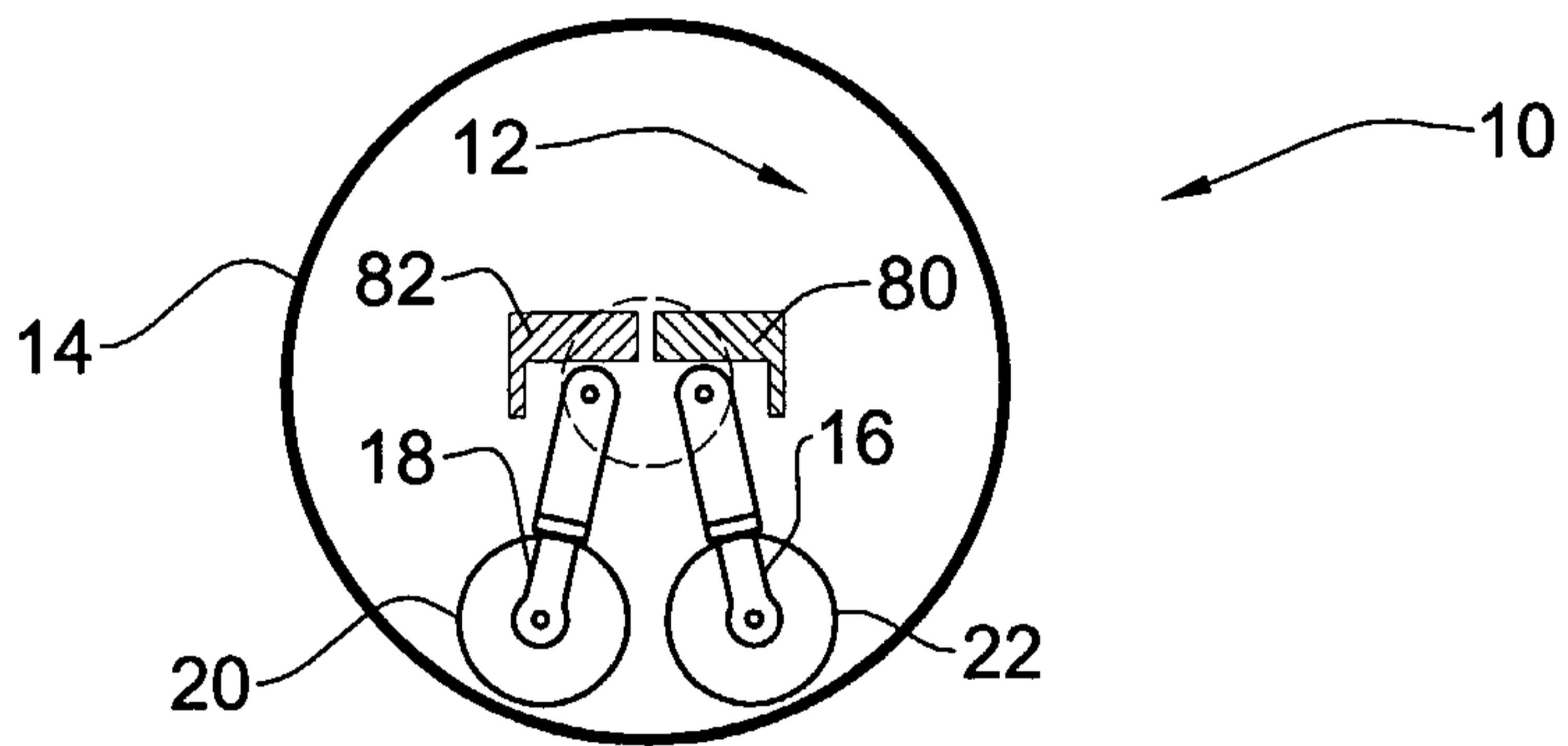

FIG. 3A

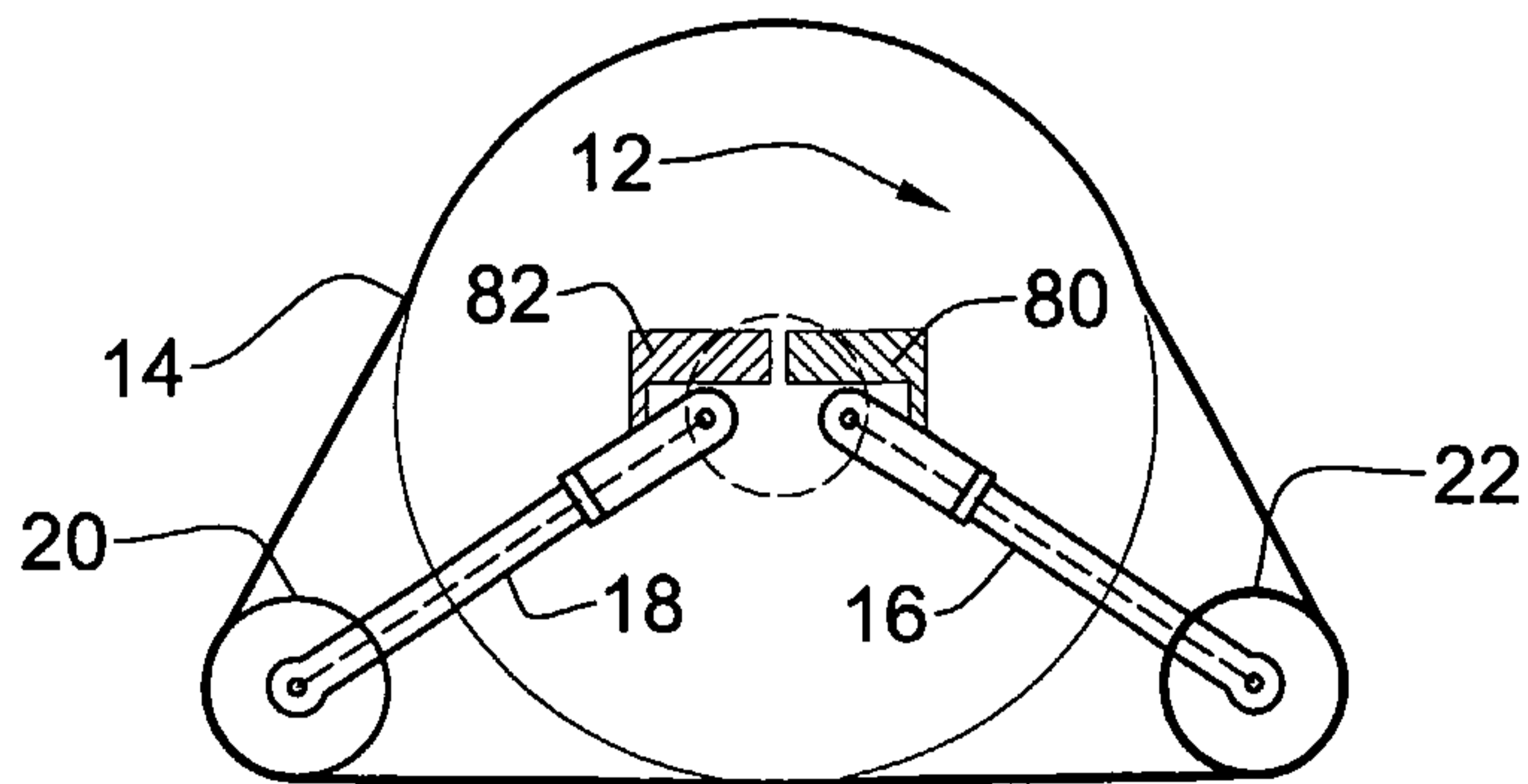

FIG. 3B

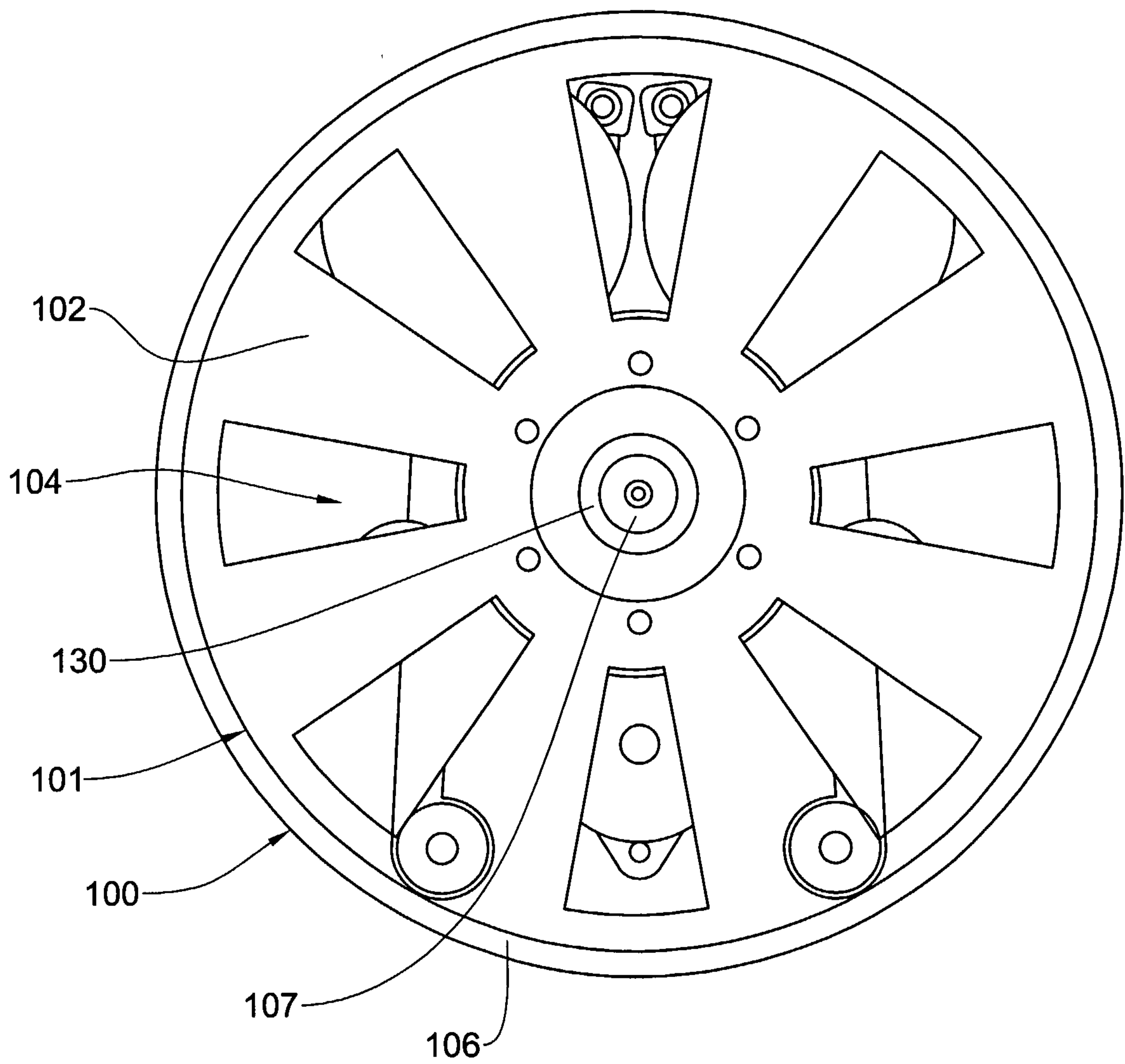

FIG. 4A

4/15

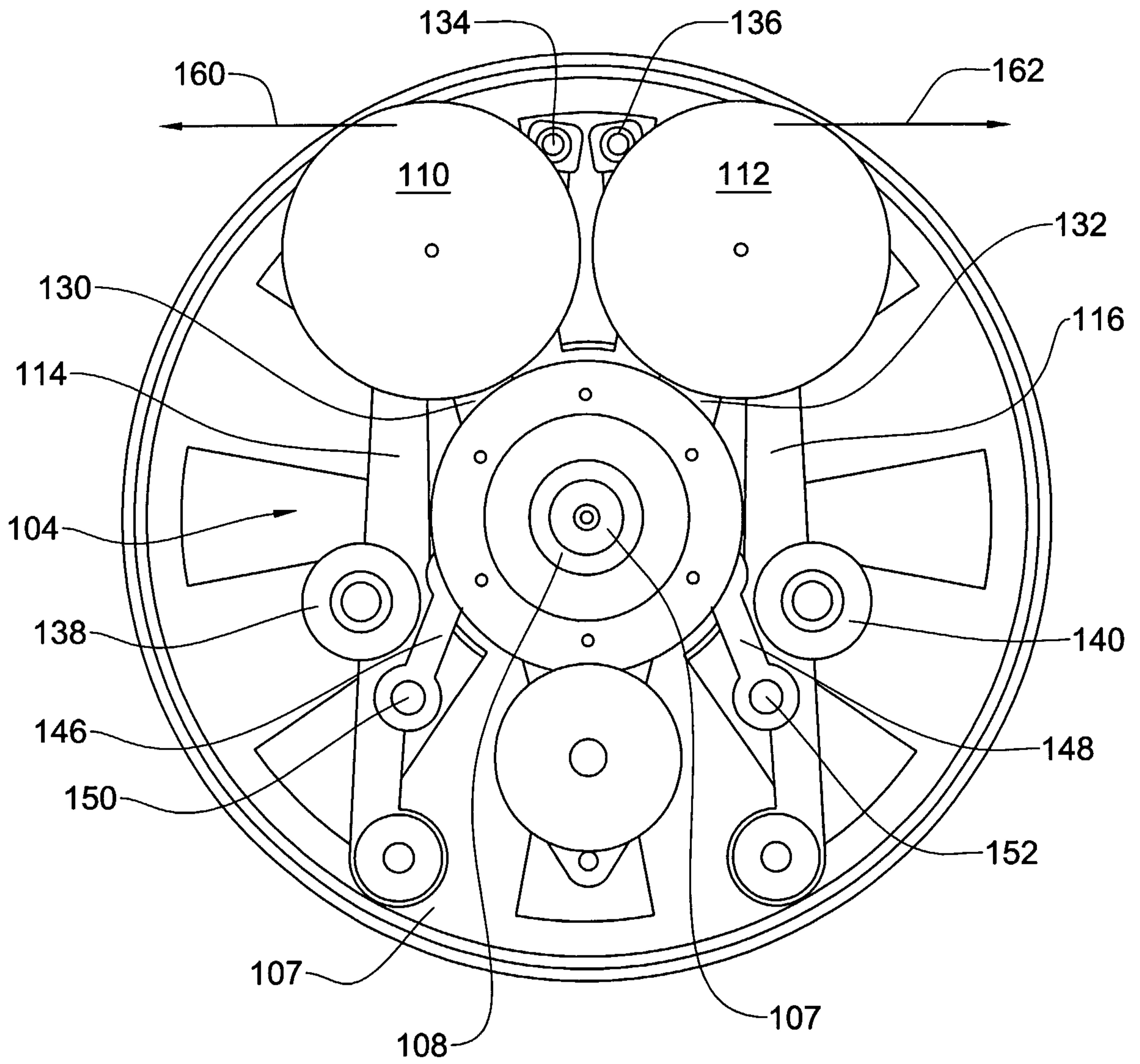

FIG. 4B

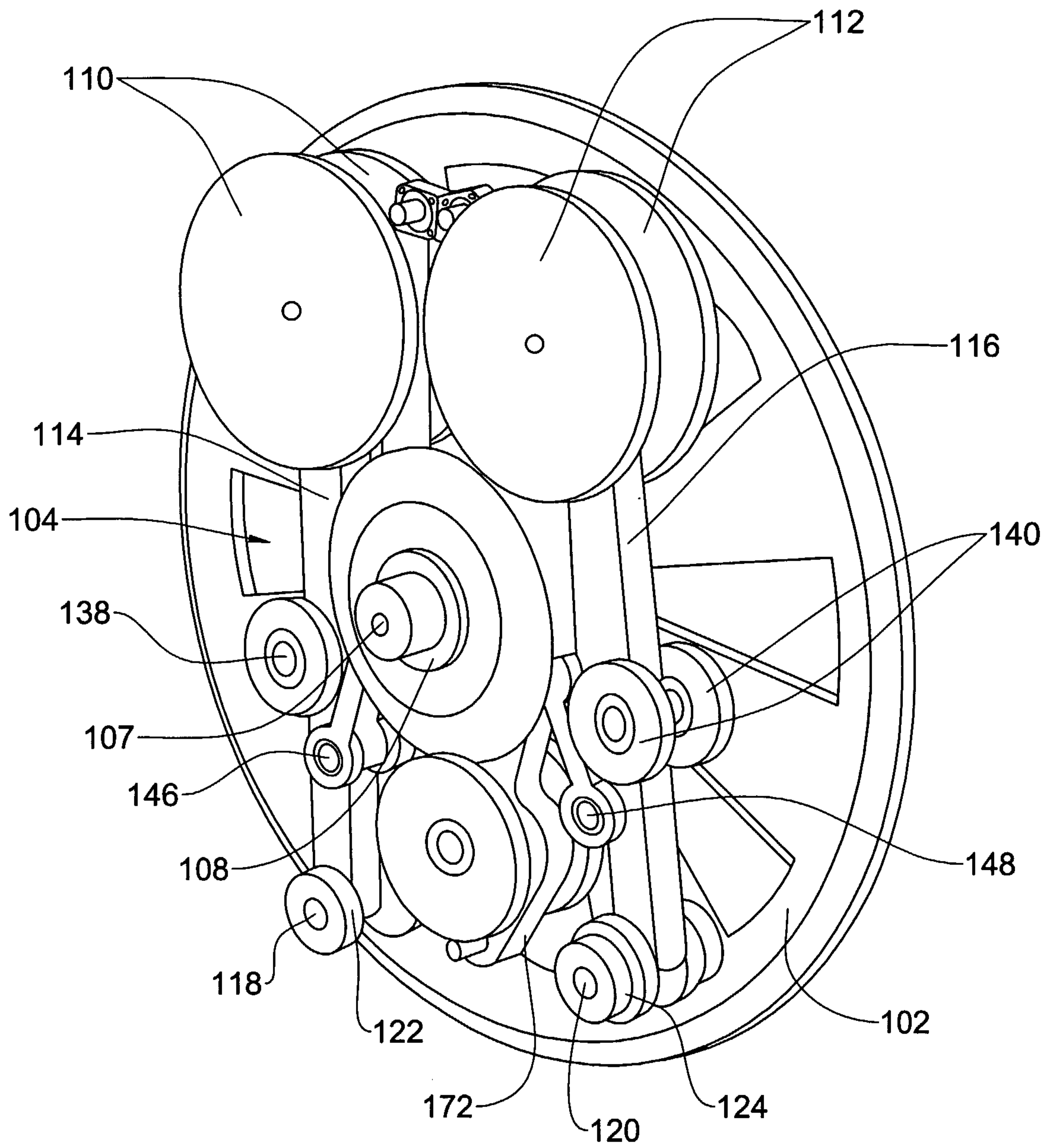

FIG. 4C

6/15

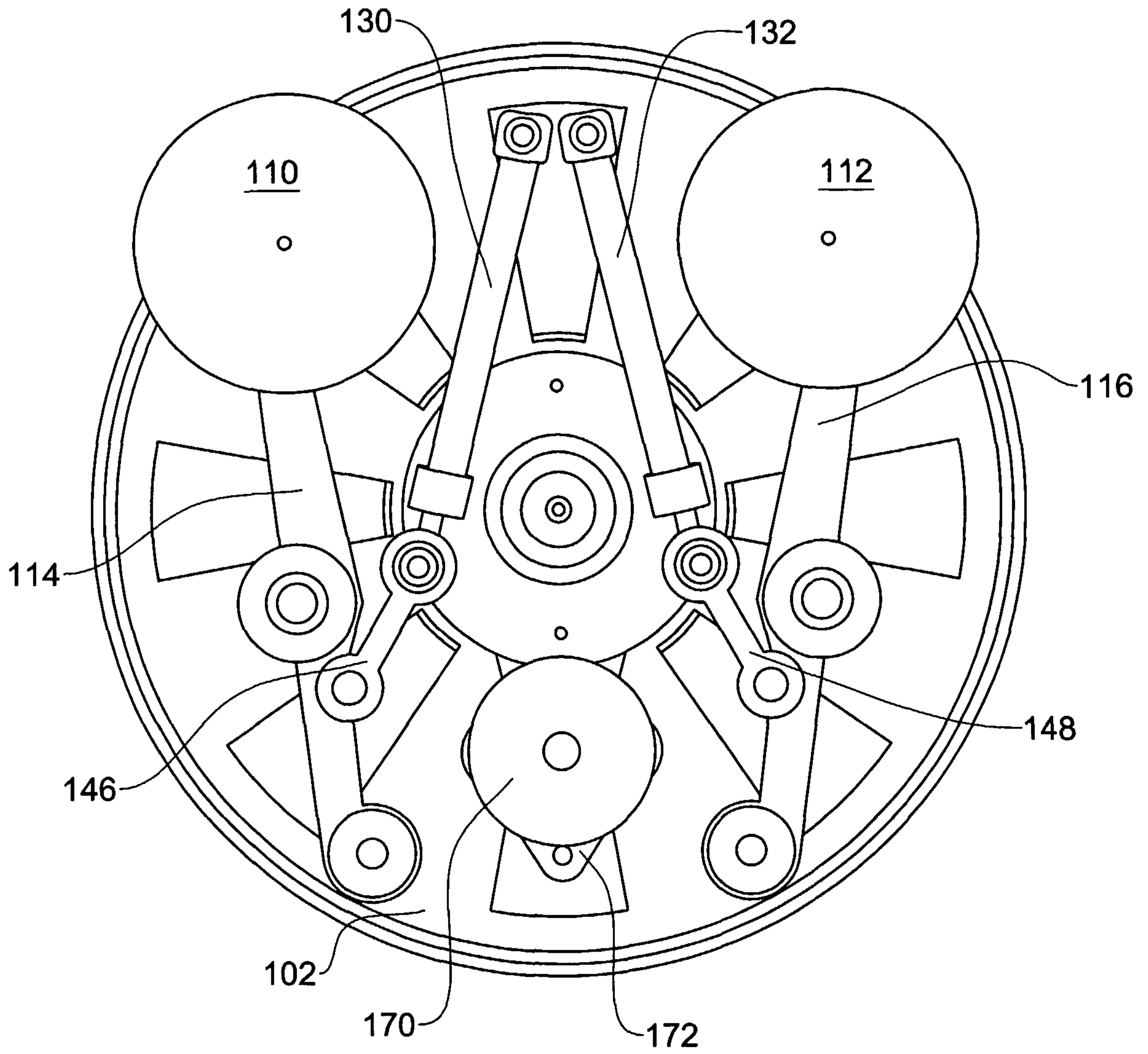

FIG. 4D

7/15

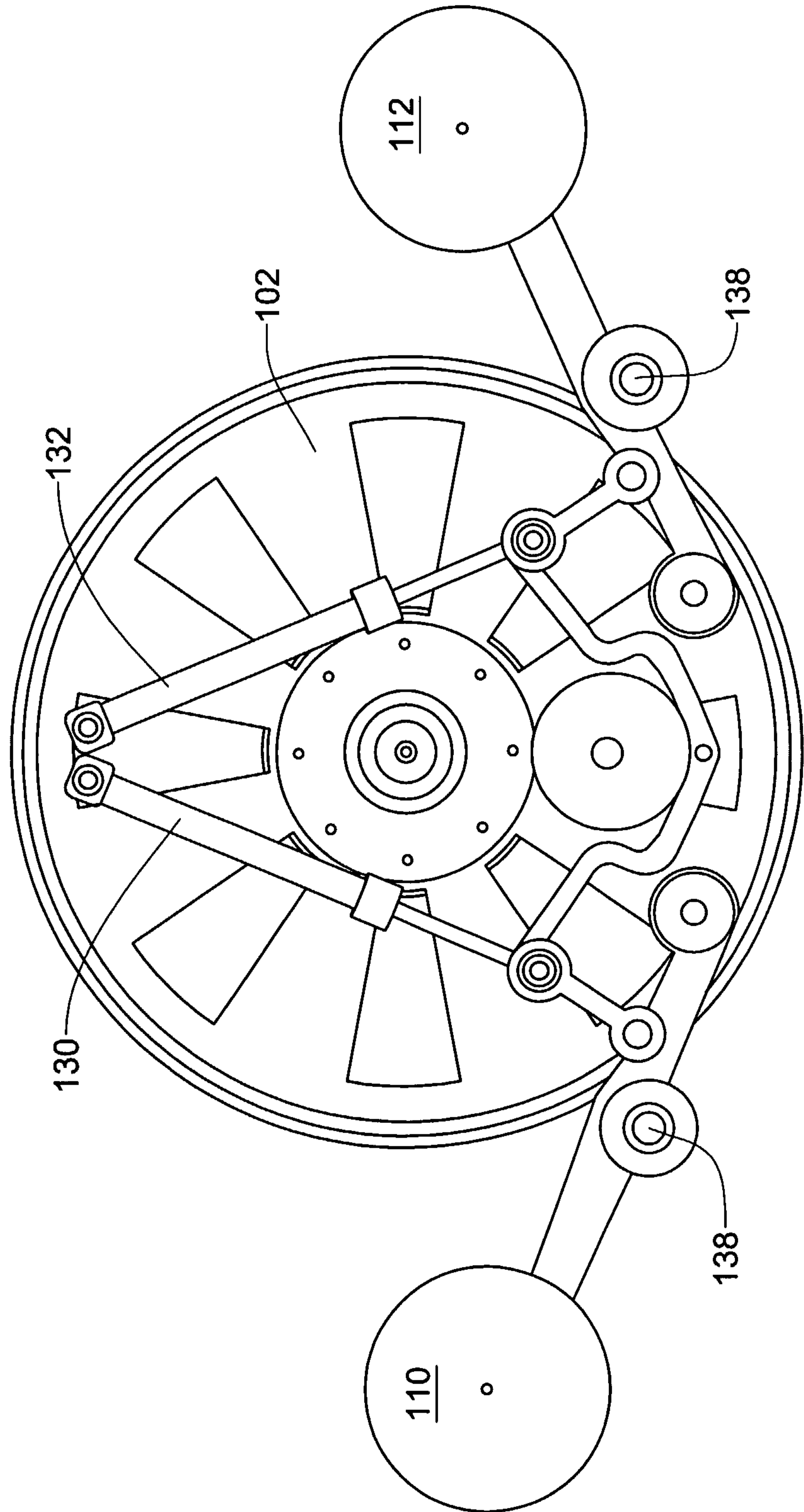

FIG. 4E

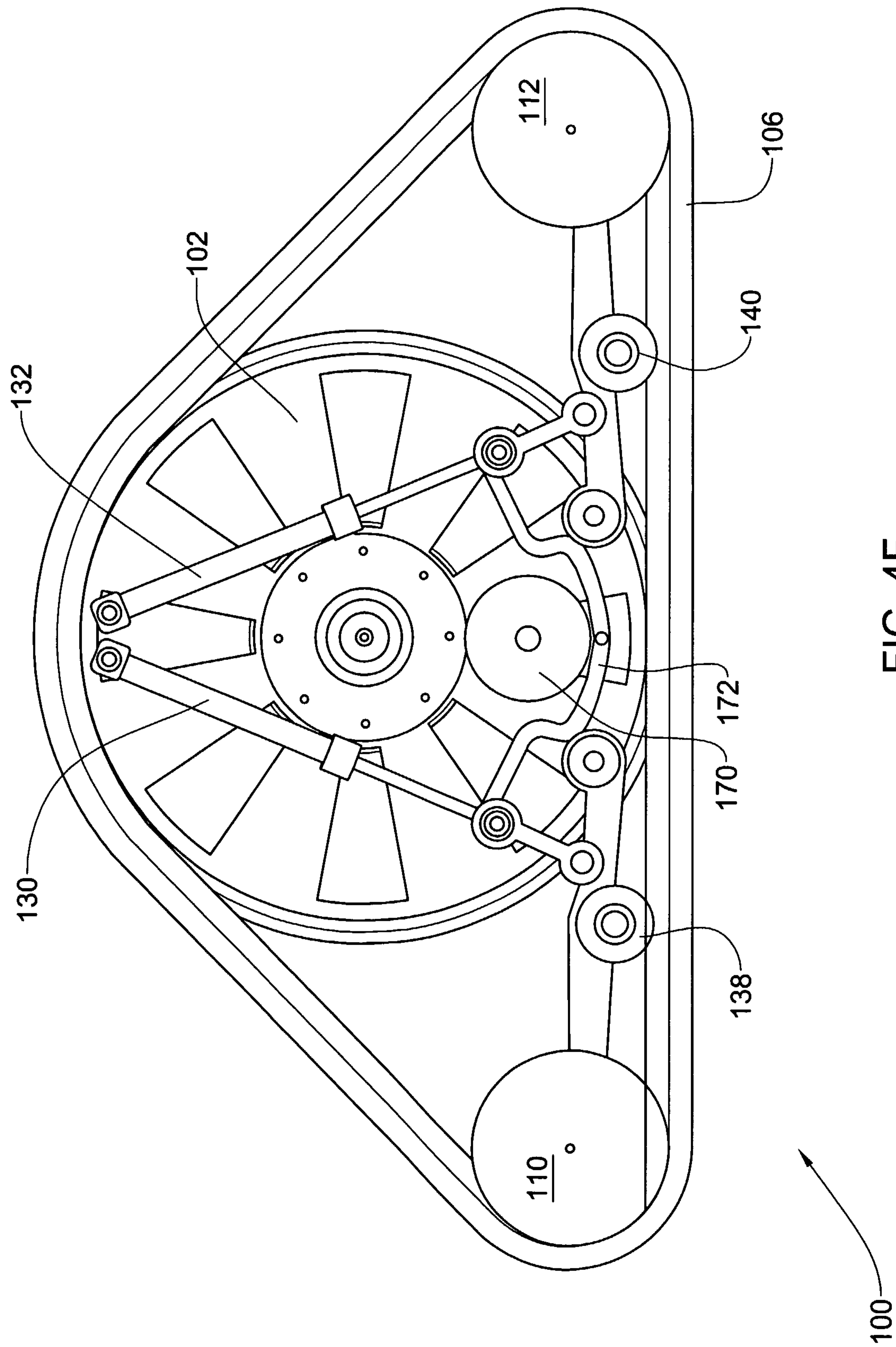

FIG. 4F

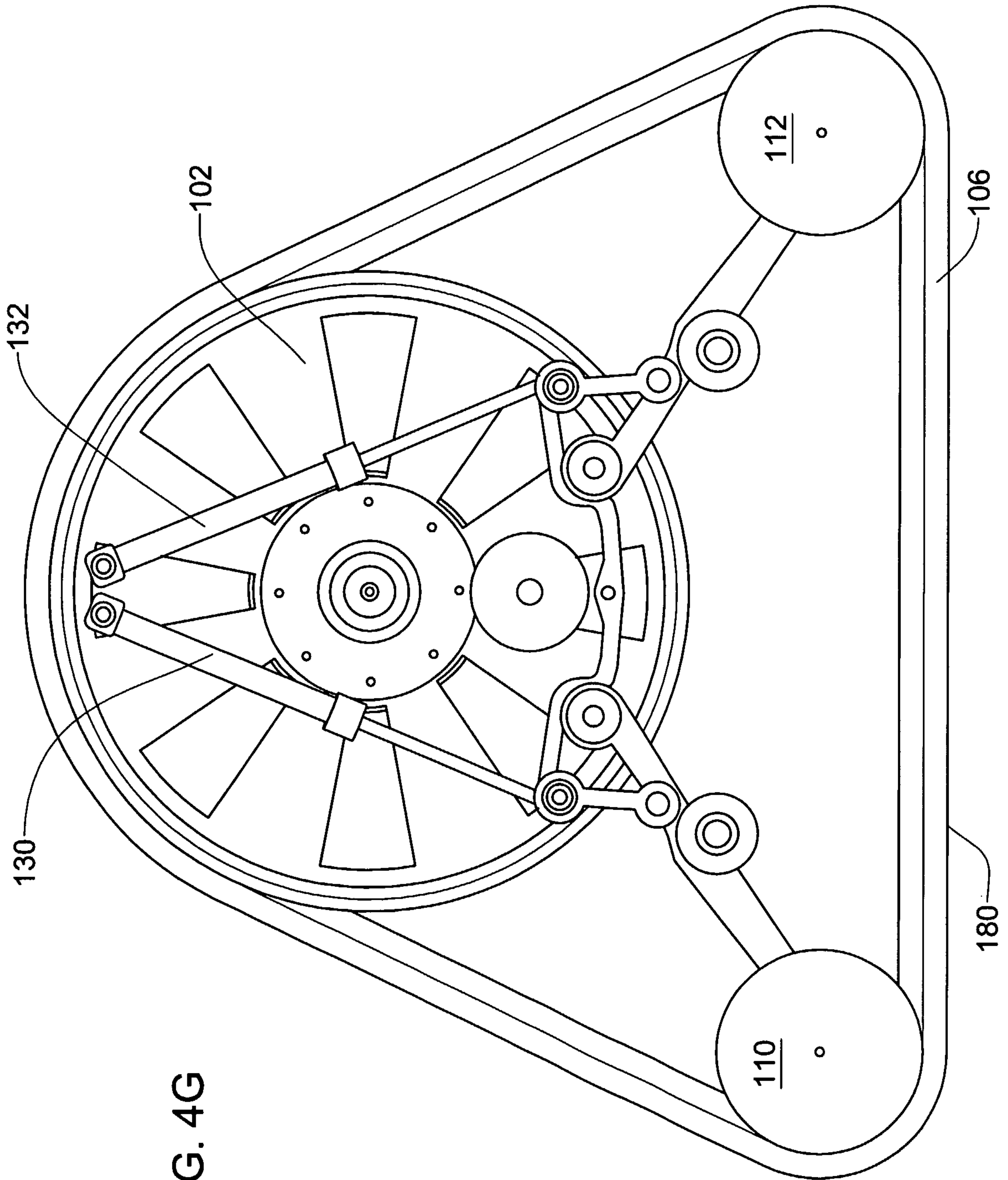

FIG. 4G

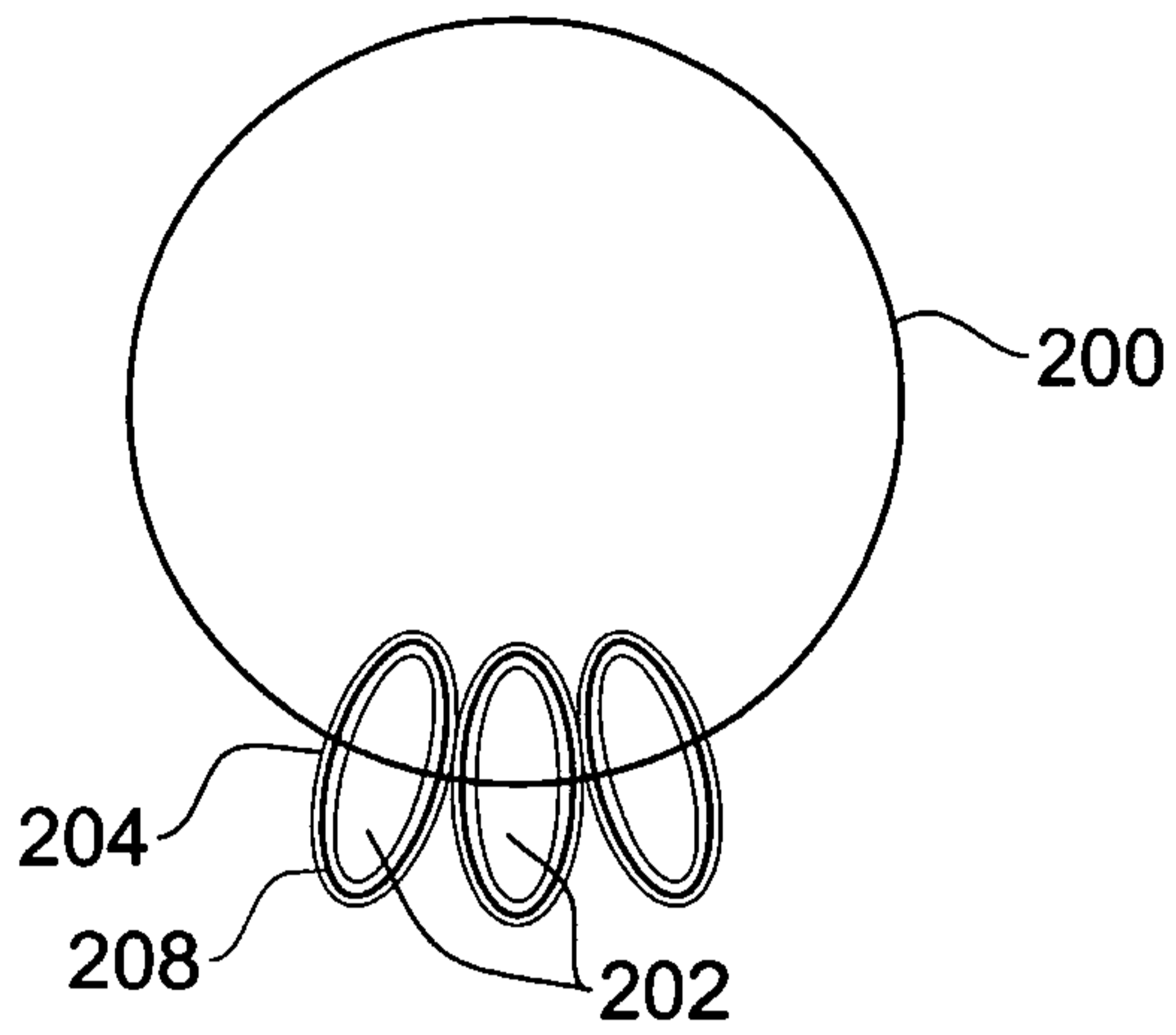

FIG. 5A

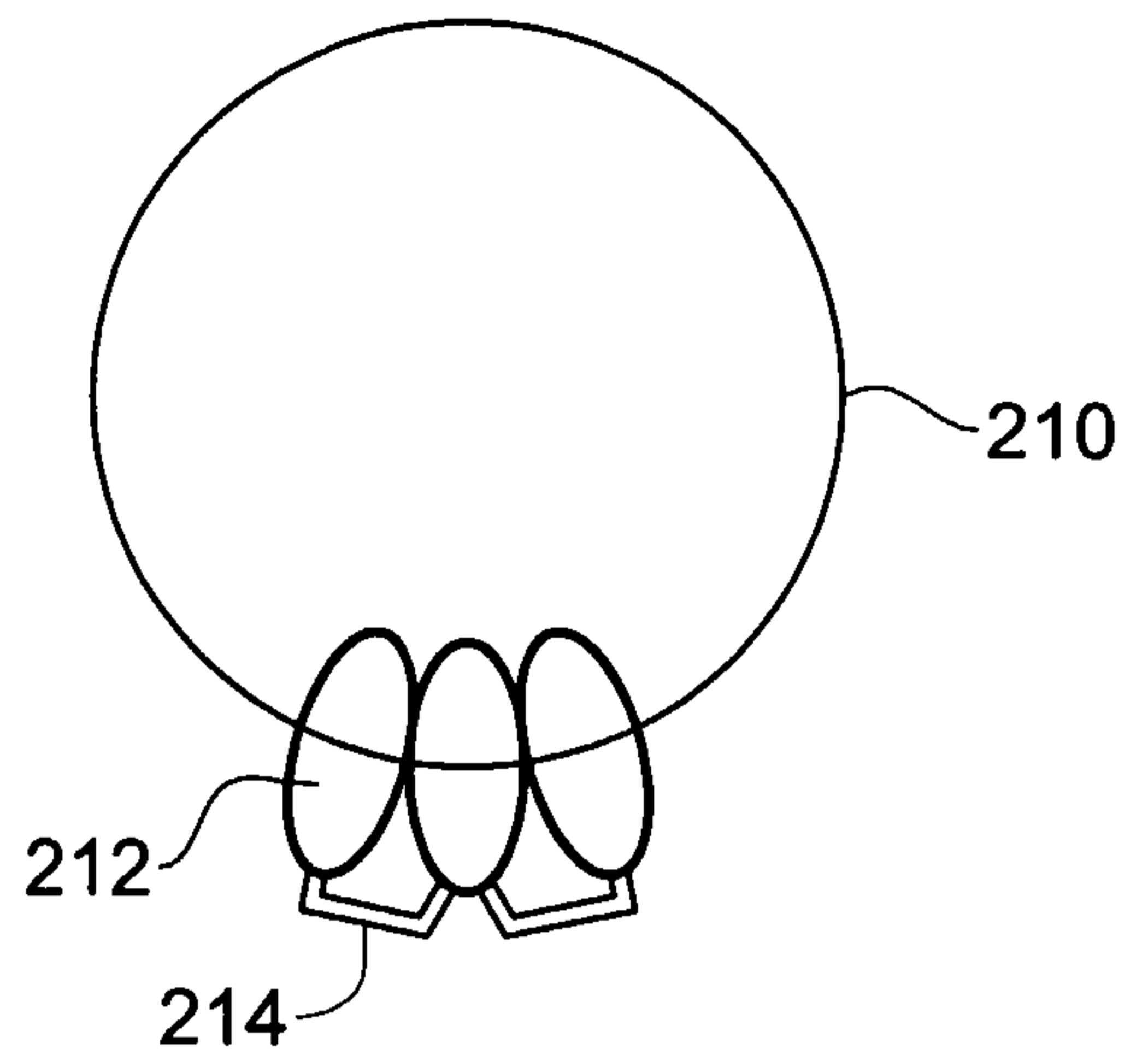

FIG. 5C



FIG. 5B

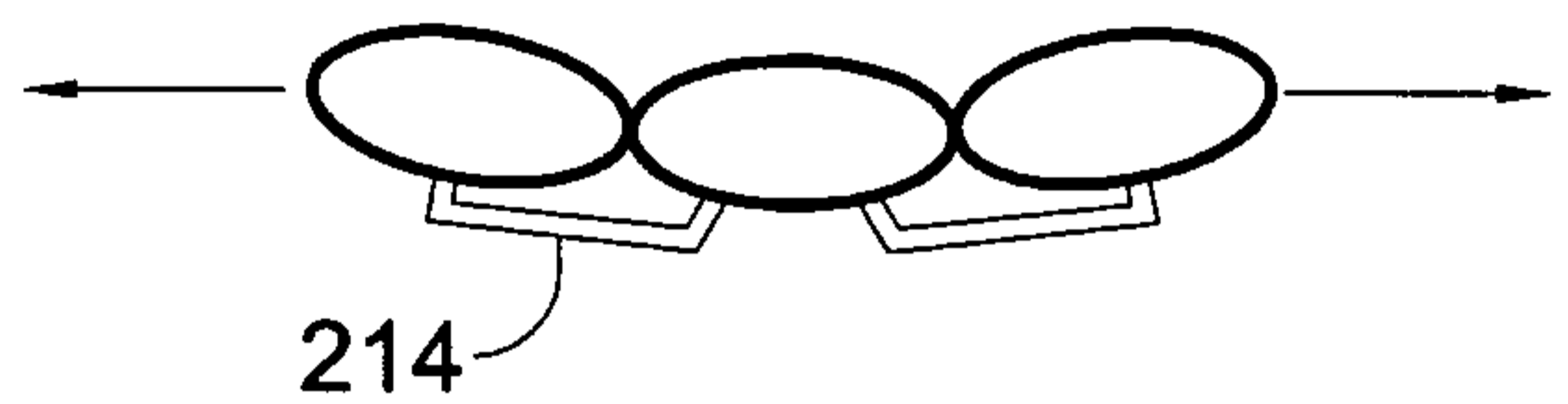

FIG. 5D

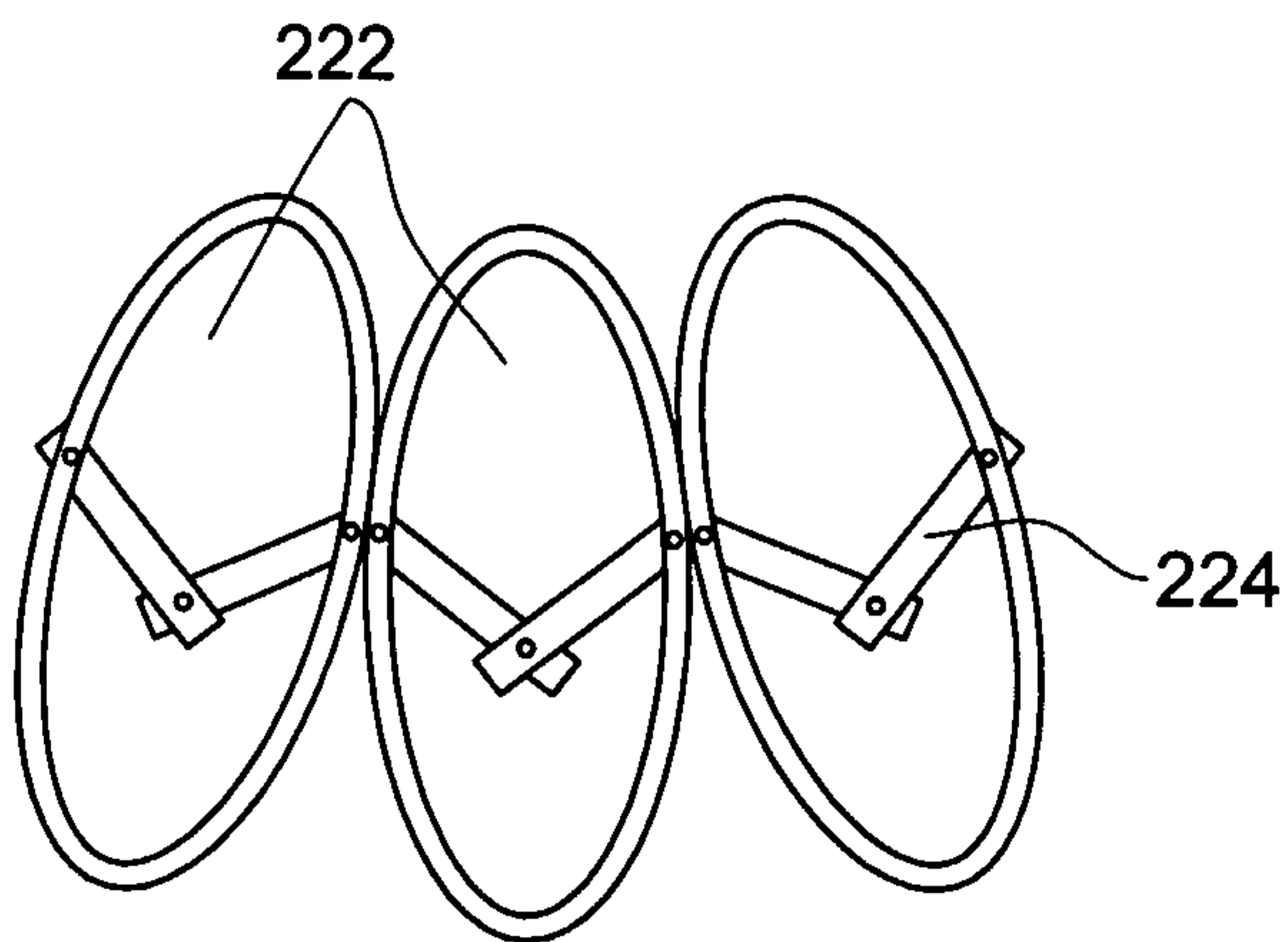

FIG. 6

12/15

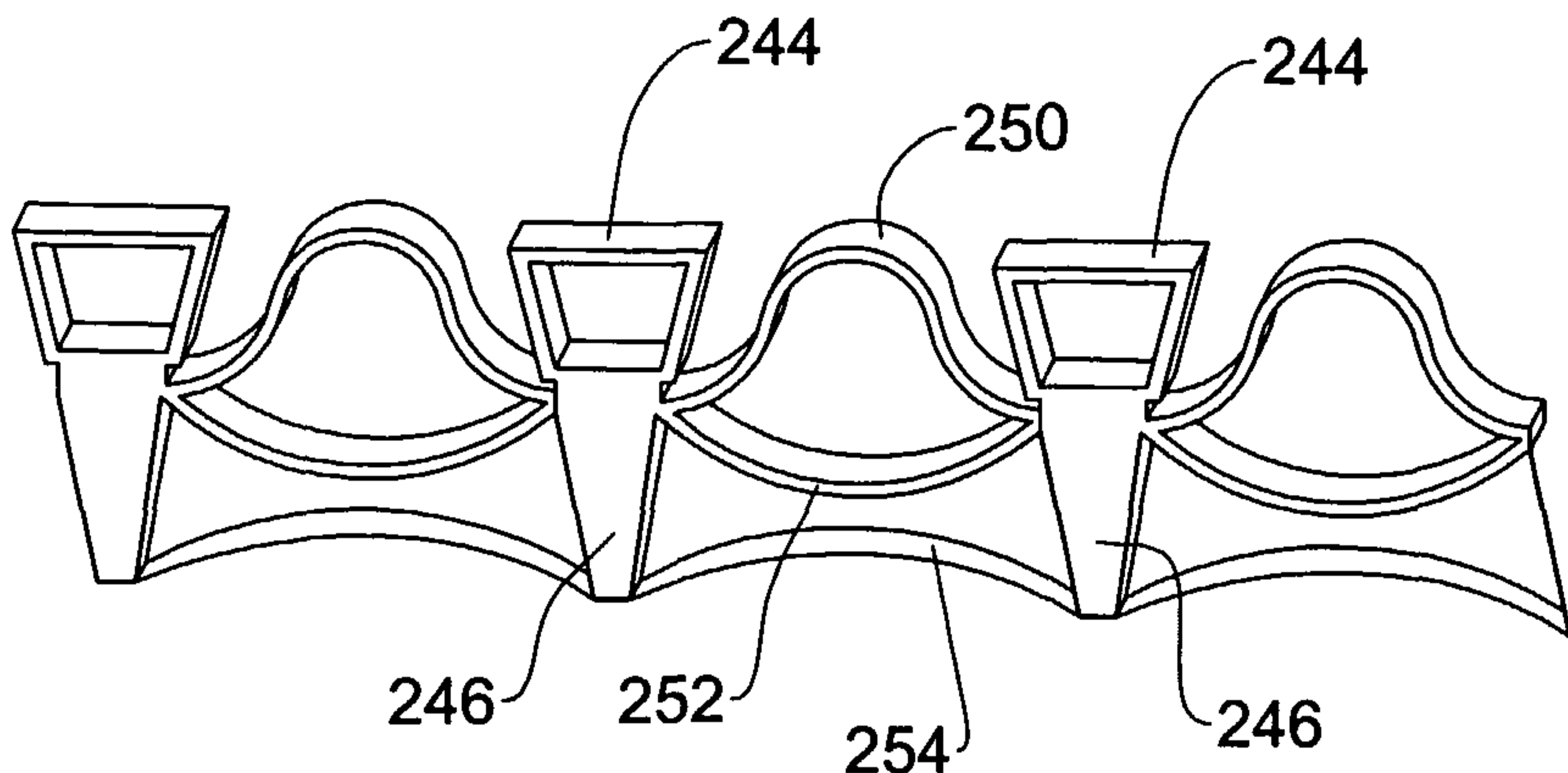

FIG. 8A

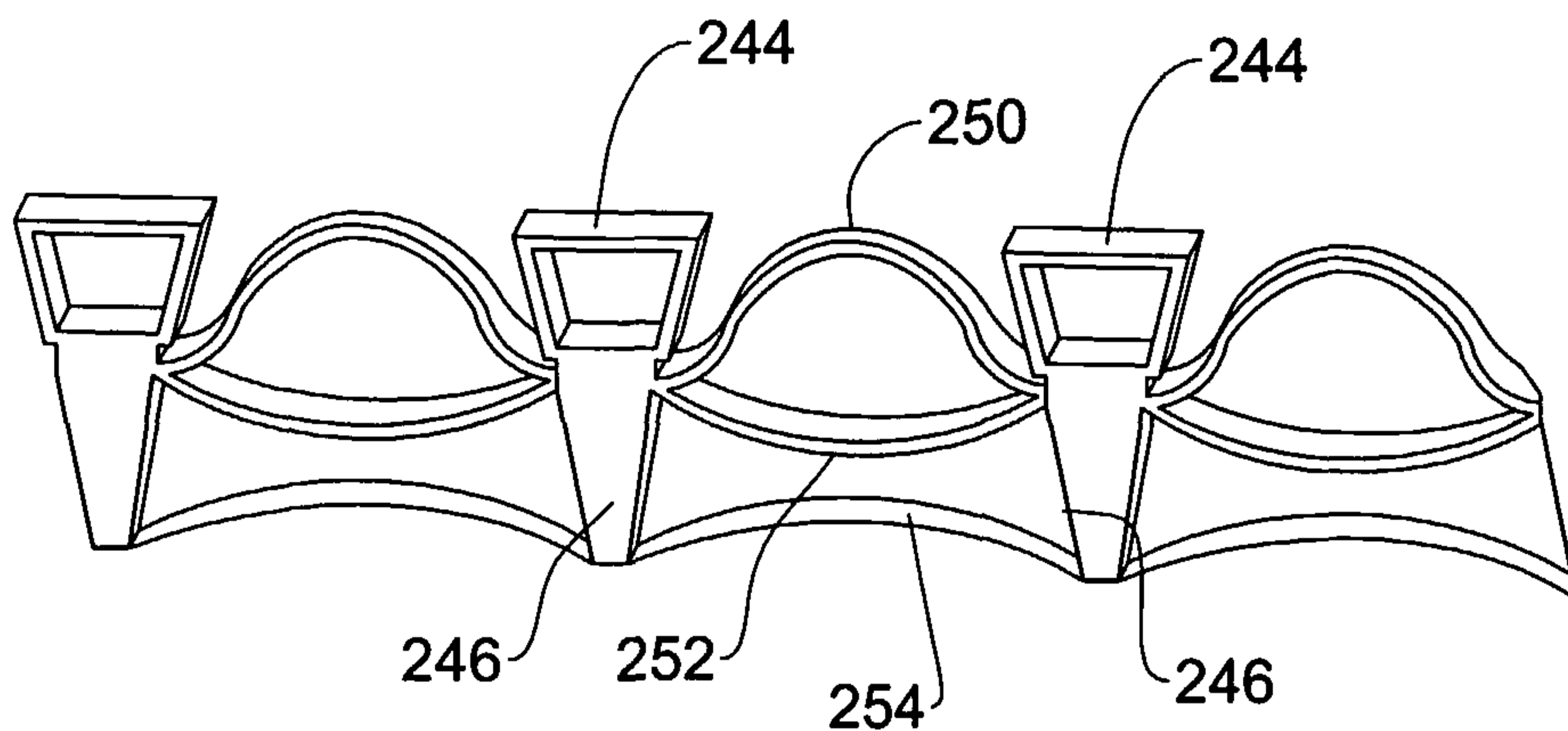

FIG. 8B

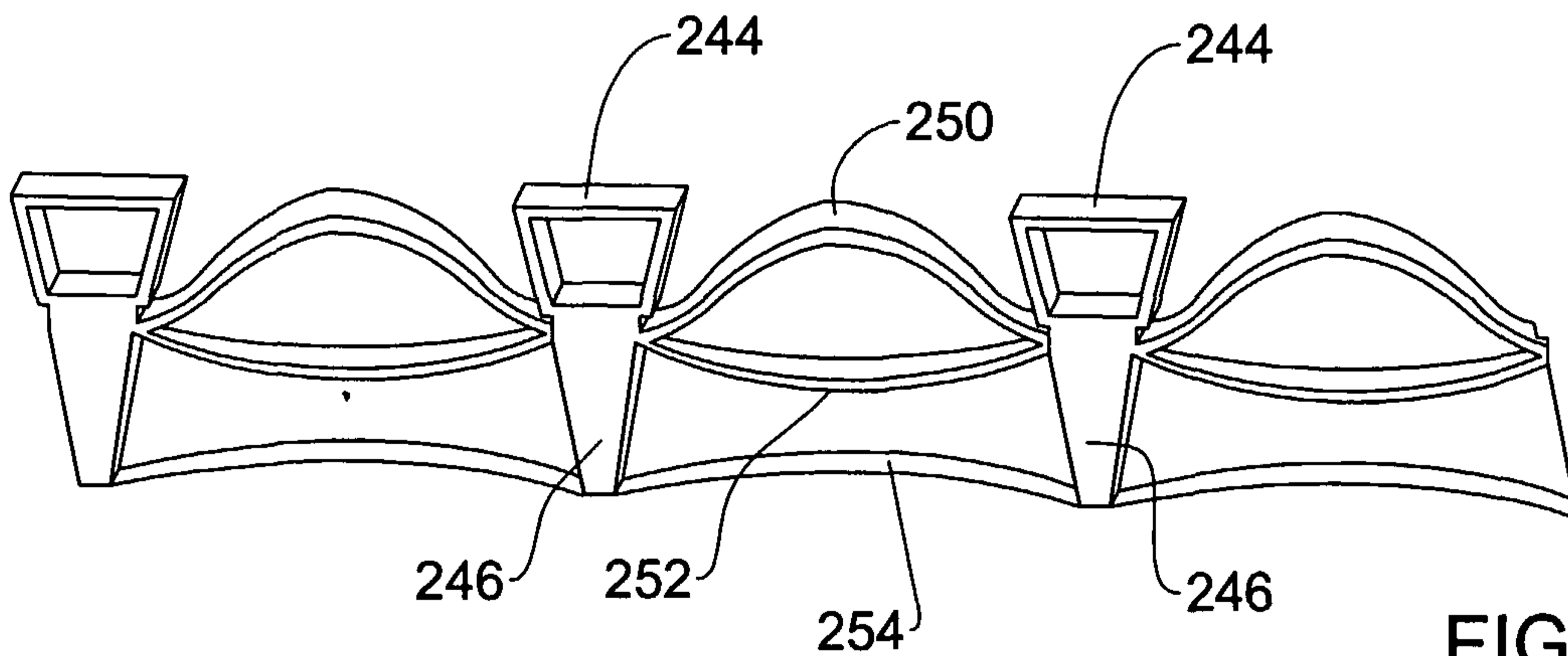

FIG. 8C

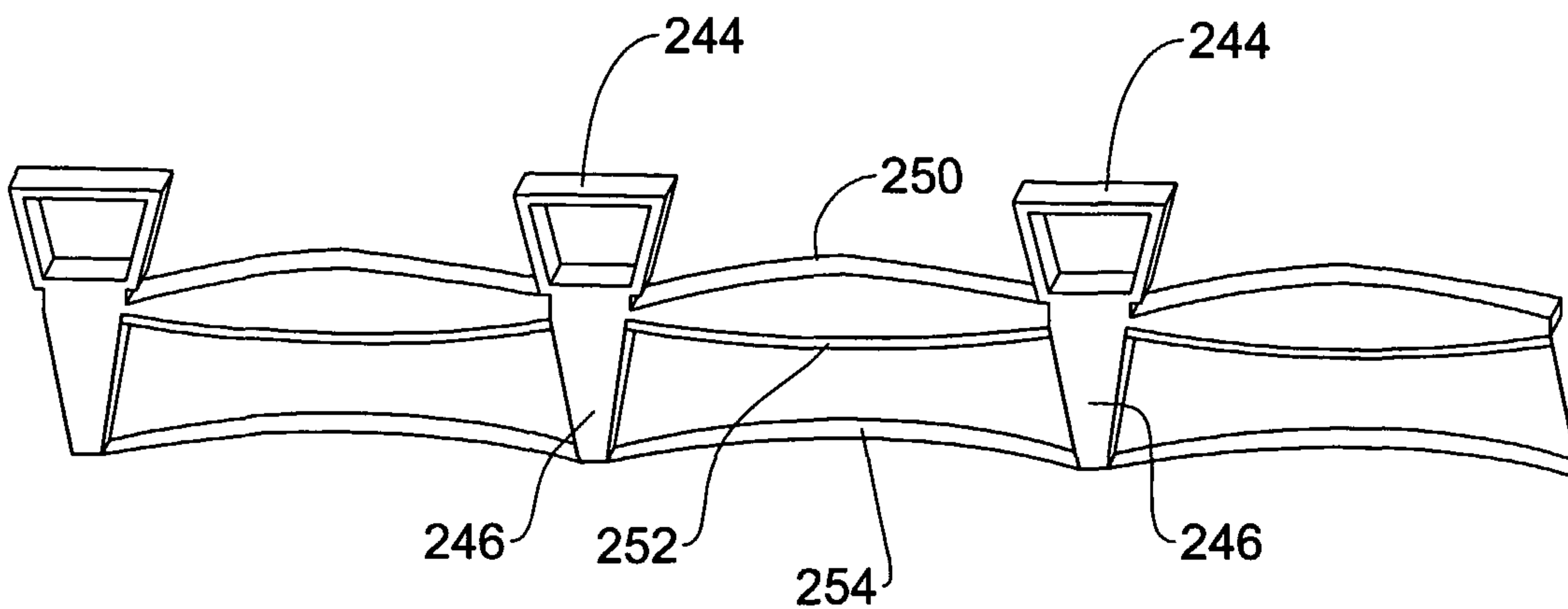

FIG. 8D

13/15

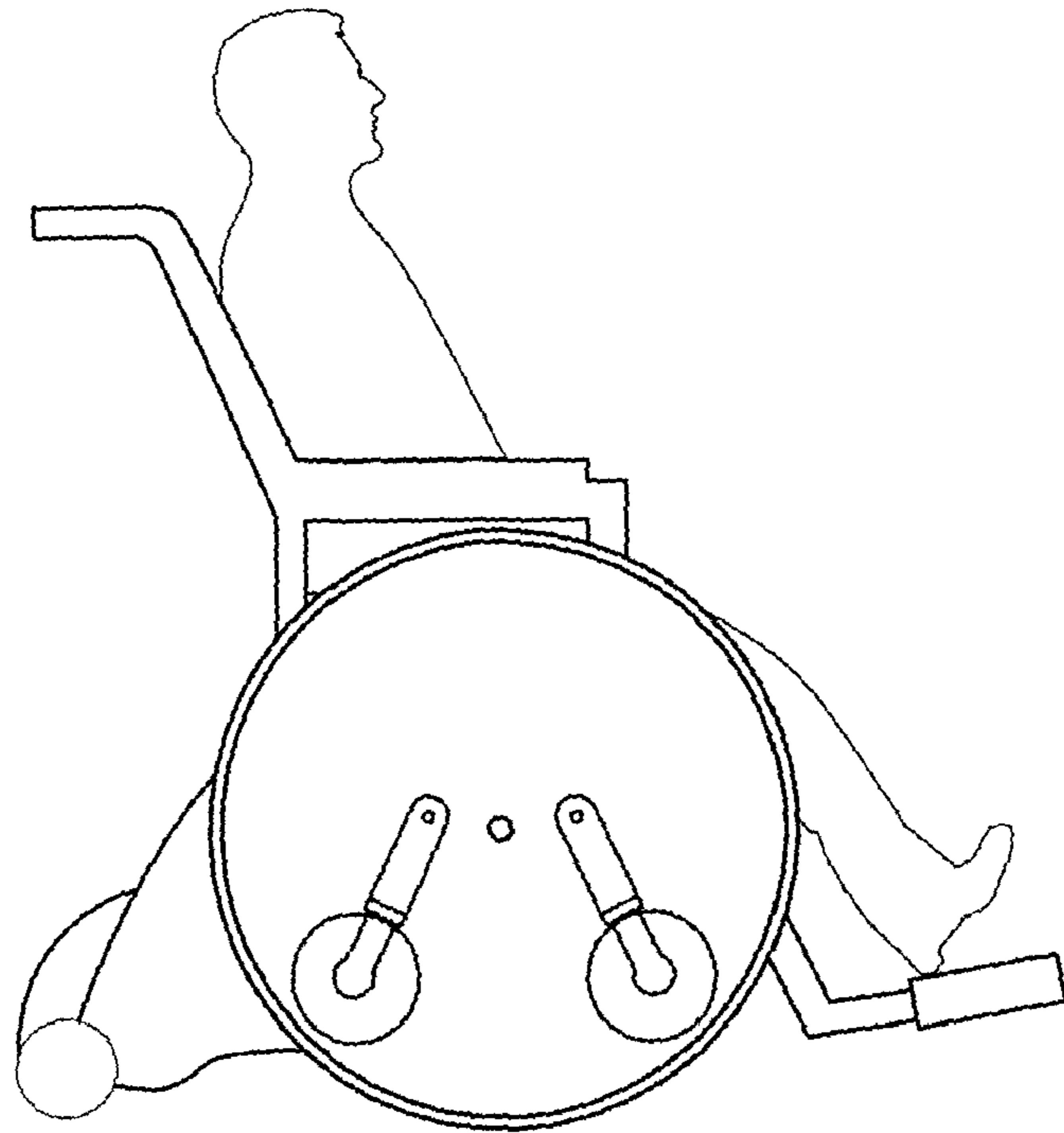

FIG. 9A

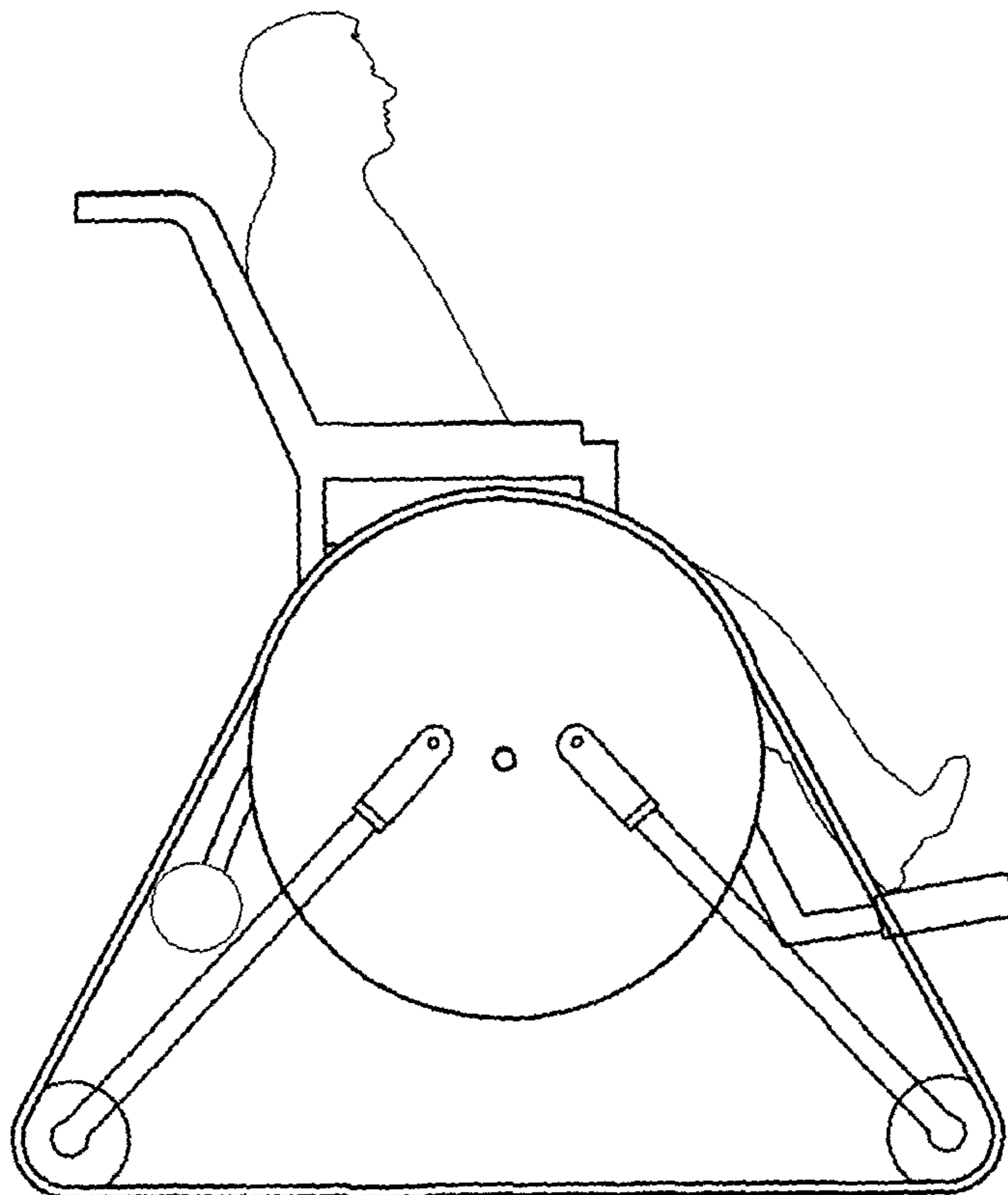

FIG. 9B

14/15

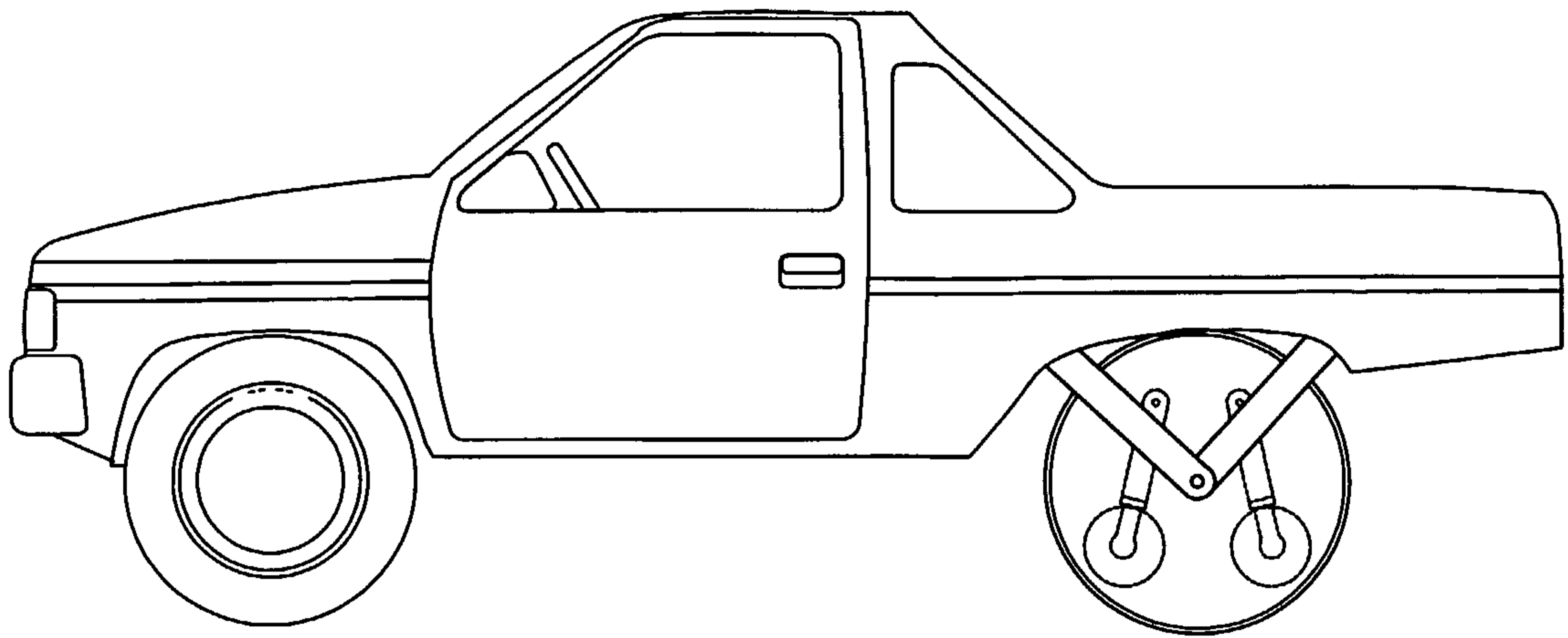

FIG. 10A

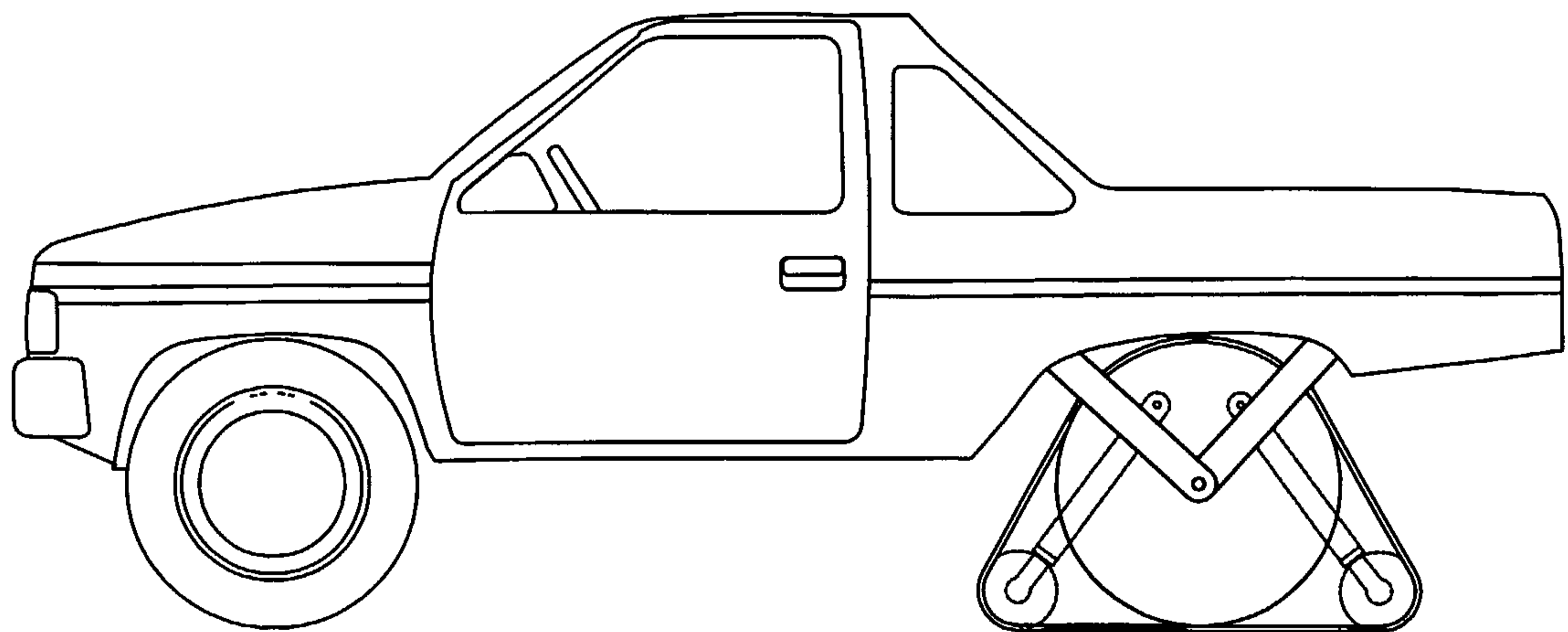

FIG. 10B

15/15

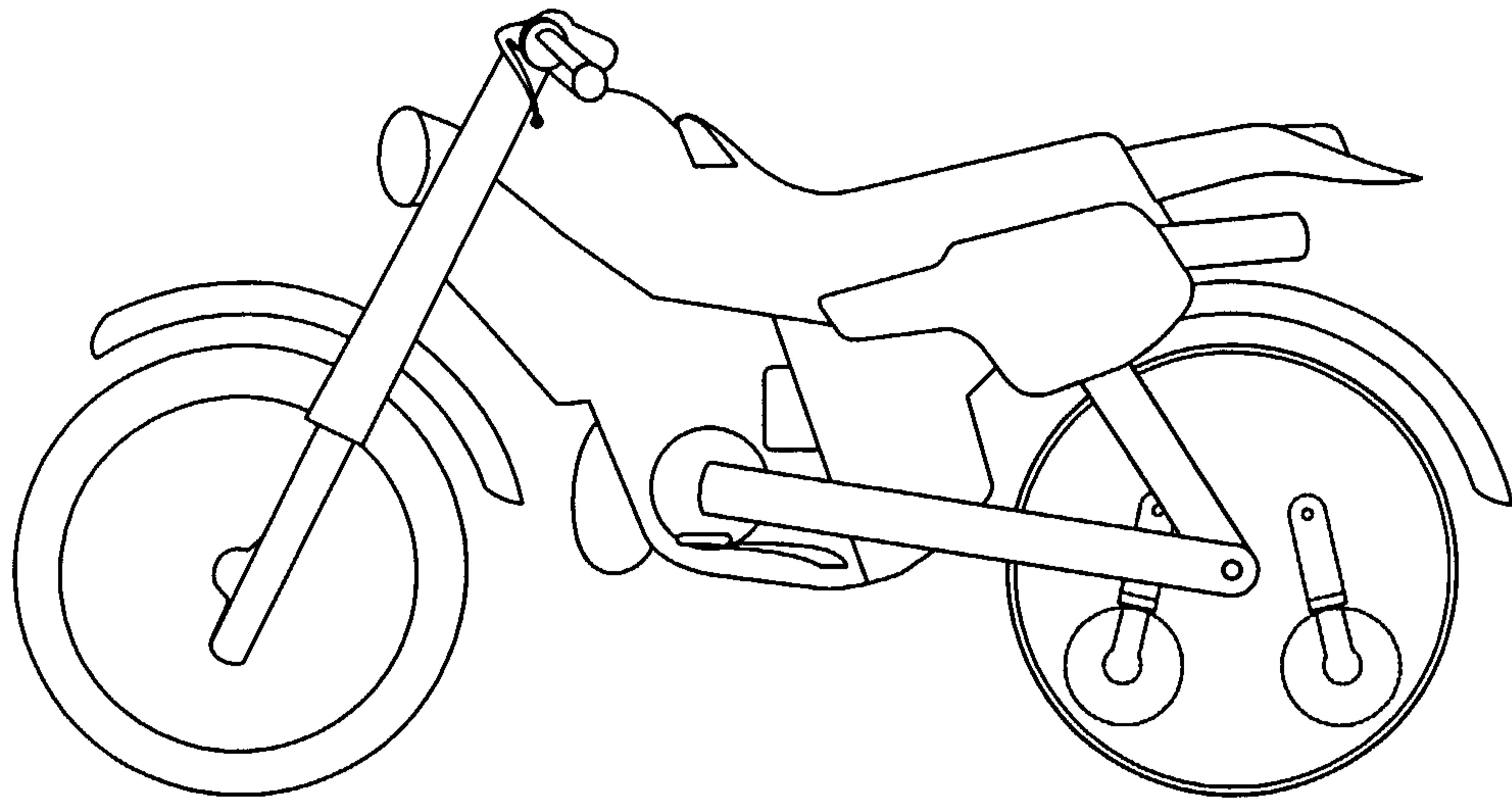

FIG. 11A

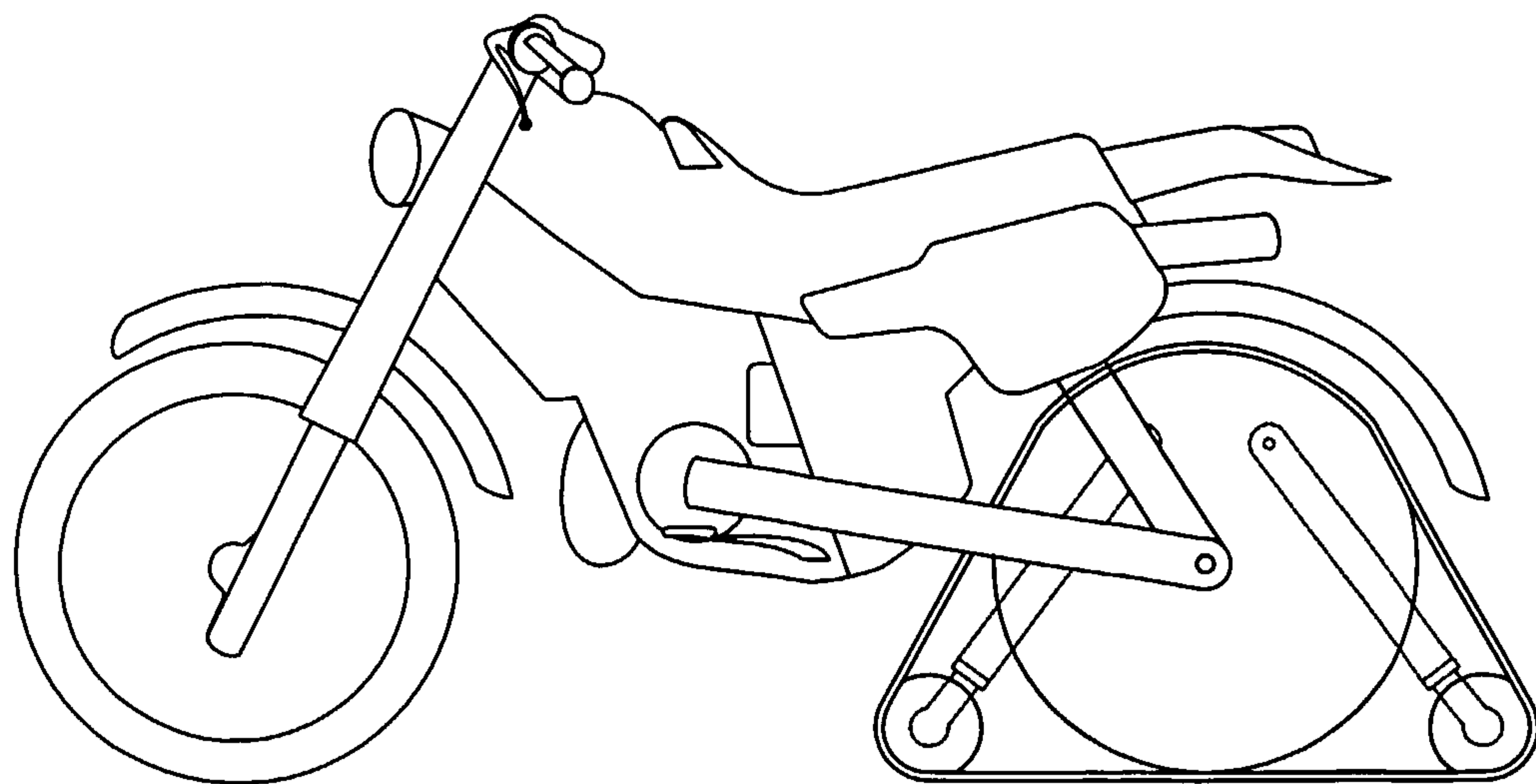

FIG. 11B

