



INTERNATIONAL APPLICATION PUBLISHED UNDER THE PATENT COOPERATION TREATY (PCT)

<p>(51) International Patent Classification⁴ : G02B 6/38</p>	<p>A1</p>	<p>(11) International Publication Number: WO 86/ 01610 (43) International Publication Date: 13 March 1986 (13.03.86)</p>
<p>(21) International Application Number: PCT/US85/01625 (22) International Filing Date: 26 August 1985 (26.08.85) (31) Priority Application Number: 645,976 (32) Priority Date: 31 August 1984 (31.08.84) (33) Priority Country: US (71) Applicant: AMP INCORPORATED [US/US]; 470 Friendship Road, Harrisburg, PA 17105 (US). (72) Inventor: HUBER, John, Henry ; 6131 Bluestone Avenue, Harrisburg, PA 17112 (US). (74) Agents: SEITCHIK, Jay, L. et al.; AMP Incorporated, 470 Friendship Road, Harrisburg, PA 17105 (US).</p>		<p>(81) Designated States: AT (European patent), BE (European patent), CH (European patent), DE (European patent), FR (European patent), GB (European patent), IT (European patent), JP, LU (European patent), NL (European patent), SE (European patent). Published <i>With international search report.</i></p>
<p>(54) Title: A CONNECTOR FOR AN OPTICAL FIBER</p>		
<p>(57) Abstract</p> <p>A connector for an optical fiber comprises a ferrule (16) for surrounding the fiber (80), a clamp (18) of resiliently compressible material for surrounding the fiber (80), and a body (20) for connection to the ferrule (16), the body (20) having a tubular portion divided into fingers (66) for gripping a buffer jacket (82) surrounding the fiber (80), characterized in that, a conical portion (52) of the clamp (18) is inserted in the ferrule (16) and is urged by the fingers (66) against an internal surface (32) of the ferrule (16) that deforms the clamp (18) radially to grip the fiber (80), and the fingers (66) are inserted in the ferrule (16) and are urged by the internal surface (28) to compress radially against the buffer jacket (82).</p>		

FOR THE PURPOSES OF INFORMATION ONLY

Codes used to identify States party to the PCT on the front pages of pamphlets publishing international applications under the PCT.

AT Austria	GA Gabon	MR Mauritania
AU Australia	GB United Kingdom	MW Malawi
BB Barbados	HU Hungary	NL Netherlands
BE Belgium	IT Italy	NO Norway
BG Bulgaria	JP Japan	RO Romania
BR Brazil	KP Democratic People's Republic of Korea	SD Sudan
CF Central African Republic	KR Republic of Korea	SE Sweden
CG Congo	LI Liechtenstein	SN Senegal
CH Switzerland	LK Sri Lanka	SU Soviet Union
CM Cameroon	LU Luxembourg	TD Chad
DE Germany, Federal Republic of	MC Monaco	TG Togo
DK Denmark	MG Madagascar	US United States of America
FI Finland	ML Mali	
FR France		

A CONNECTOR FOR AN OPTICAL FIBER

A connector for an optical fiber comprises a ferrule for surrounding the fiber, a clamp of resiliently compressible material for surrounding the fiber, and a body for connection to the ferrule, the body having a tubular portion divided into fingers for gripping a buffer jacket surrounding the fiber, characterized in that,

a conical portion of the clamp is inserted in the ferrule and is urged by the fingers against an internal surface of the ferrule that deforms the clamp radially to grip the fiber, and the fingers are inserted in the ferrule and are urged by the internal surface to compress radially against the buffer jacket.

It is known from U.S. Patent 3,946,467 to provide a connector for an optical fiber, wherein the connector has a tubular portion for surrounding the fiber, the tubular portion is axially split to provide a finger, and a sleeve for surrounding the tubular portion and for sliding axially along the tubular portion to engage the finger and deflect the finger into frictional engagement with the fiber, thereby to grip the fiber.

It is known from U.S. Patent 4,190,317 to provide a connector for an optical fiber, wherein the connector has a tubular portion for surrounding the fiber, an enlarged counterbore in an end of the tubular portion, and a conical and resilient insert member for surrounding the fiber, and the insert member is compressed radially when inserted in the counterbore, thereby to grip the fiber.

An advantage of the invention is that an optical fiber is engaged by fingers that urge an elastomeric clamp against an internal surface of a ferrule that surrounds an end of an optical fiber to align the same, and the internal surface urges the fingers to grip a jacket portion of the fiber and to compress the clamp radially to grip the fiber and the internal surface further compresses the clamp radially to grip the fiber. Thereby, the fiber is gripped more securely than by fingers of a tubular body

urged radially by a ring or by an elastomeric clamp compressed within a counterbore.

The invention will be described by way of example with reference to the accompanying drawings in which:

5 FIGURE 1 is a perspective view of an optical fiber connector of the present invention;

FIGURE 2 is an exploded perspective view of the present invention;

10 FIGURE 3 is a view, partially in section and partially exploded, of the present invention;

FIGURE 4 is a section view of the invention assembled with an optical fiber cable; and

FIGURE 5 is a fragmentary sectional view of a one-piece ferrule of the present invention.

15 A connector of the invention 10 is shown in Figure 1 assembled with an optical fiber cable 12 and aligned to be received in a connector member 14 of the type disclosed in U.S. Patent No. 4,167,303.

20 The details of the connector 10 are shown in Figures 2 and 3. The connector 10 includes a ferrule 16, a clamp 18, a body 20, and an outer shell 22. The ferrule 16 is a two-part member having a body portion 24 and a nose end portion 26 of resilient material such as plastic. The body portion 24 is preferably made of rigid metal, such as brass, and has an axial passage with an internal surface 28. The passage further has an internally threaded entry portion 30 and a portion with a truncated conical surface portion 32 of the internal surface 28, an exit passage portion 34. The outside of the body 24 has an external flange 36 and an annular recess 38. The resilient nose end portion 26 has an axial bore 40 aligned with the bore portion 34 and a narrow exit bore portion 42 at a front mating end 44. The nose end portion 26 has an outer tapered conical portion 46 and an inwardly directed annular flange 48 which engages the annular recess 38 to secure the nose end portion 26 on the body
35 24.

The clamp 18 is preferably made of a resilient elastomeric material and has an axial bore 50 and an outer profile including a tapered conical portion 52 and an annular shoulder 54. The profile of the conical portion 52 is such that it will interface with the conical surface portion 32 of the body 24.

The body 20 is an elongated metal member having an axial passage 56 extending through the body. Body portion 58 has external threads 60 intermediate an enlarged head portion 62, which has a knurled outer surface 64. Body 20 includes a tubular portion divided into a plurality of cantilever fingers 66, which have inwardly projecting, buffer clamping teeth 68 and outwardly projecting, raised clamping rings 70, 72.

The outer shell 22 is a generally cylindrical member of soft metal having an external flange 74 at one end, a stepped diameter profile 76 intermediate its ends, and an inwardly turned, radial flange 78 at a second end.

The cable 12 includes an optical fiber 80 enclosed within a buffer jacket 82 and strength members 84, such as Kevlar, and an outer jacketing 86.

The cable 12 is prepared in known fashion to expose a section of the buffer jacket 82 and the fiber 80. The fiber 80 and the buffer jacket 82 are passed through the shell 22 and the passage 56 through the body 20. The fiber 80 is passed through the bore 50 of the clamp 18. Cable 12, clamp 18 and body 20 are assembled in the passage 28 of the ferrule 16, with the fiber 80 passing through the bore portion 34 and the bore portions 40 and 42 to extend beyond the end 44 of the ferrule 16. The threads 60 are advanced along the threads 30 to drive the cable 12 forward until the clamp 18 engages and is compressed against the surface 32 which deforms the clamp radially to grip the fiber 80. The raised clamping rings 70, 72 engage the surface 28 of the passage which urges the fingers radially to compress the clamp 18 radially in turn to grip the fiber 80. The surface of the passage 28 further urges the fingers 66 radially to drive the clamping teeth 68 into the buffer

82. Thereby the cable 12 is securely gripped. The strength members 84 are located along the outside of the ferrule 16, and are covered by the outer shell 22 that is moved forward over the body 20 and a portion of the ferrule 16 until the flange 74
5 engages the flange 36. The outer shell 22 is radially deformed to engage the jacket 86 of the cable 12 as shown in Figure 4. Figures 4 and 5 show the radial compression of the clamp 18 by the ferrule 16. The radial compression of the clamp 18 on the fiber 80 centers the fiber 18 with respect to the axis of the
10 ferrule. Figure 5 further shows the ferrule alternatively as a one-piece member.

It will be appreciated that the present invention can be utilized in other configurations and that the exterior profile of the ferrule is not critical to the present invention. The present
15 invention is suitable for use with simplex, duplex or multiple fiber connectors. The present invention also may be used in substantially any environment and is suitable for making a repair of an optical fiber.

20

25

30

35

CLAIMS:

1. A connector for an optical fiber comprises a ferrule (16) for surrounding the fiber (80), a clamp (18) of resiliently compressible material for surrounding the fiber (80), and a body (20) for connection to the ferrule (16), the body (20) having a tubular portion divided into fingers (66) for gripping a buffer jacket (82) surrounding the fiber (80), characterized in that,
a portion (52) of the clamp (18) is in the ferrule (16) and is urged by the fingers (66) against an internal surface (28) of the ferrule (16) that deforms the clamp (18) radially to grip the fiber (80), and the fingers (66) are in the ferrule (16) and are urged by the internal surface (28) to compress radially against the buffer jacket (82).
2. A connector for an optical fiber as recited in claim 1, wherein the clamp (18) is held by the fingers (66) and a conical portion (52) of the clamp projects outwardly of the fingers (66) to engage the internal surface (32).
3. A connector for an optical fiber as recited in claim 1, wherein the internal surface (28) includes a truncated conical portion (32) and a conical portion (52) of the clamp (18) projects from the fingers (66) and is urged by the fingers (66) against the truncated conical portion (32).
4. A connector for an optical fiber as recited in claim 1, wherein the clamp (18) is held by the fingers (66) and the fingers (66) are urged by the internal surface (28) to compress the clamp (18) radially to grip the fiber (80).
5. A connector for an optical fiber as recited in claim 1, wherein teeth (68) on the fingers (66) project toward the buffer jacket (82) and the fingers (66) are urged by the internal surface (28) toward the buffer jacket (82) to engage the teeth (66) against the buffer jacket (82).
6. A connector for an optical fiber as recited in claim 1, wherein the ferrule (16) has a rigid portion engaging the clamp (18) and the fingers (66), and a resilient portion (6) encircling an end of the fiber (80).

7. A connector for an optical fiber as recited in claim 1, wherein the clamp (18) is held by the fingers (66), teeth (68) are on the fingers (66), and the fingers (66) are urged by the internal surface (28) to engage the teeth (68) against the buffer jacket (82).

10

15

20

25

30

35

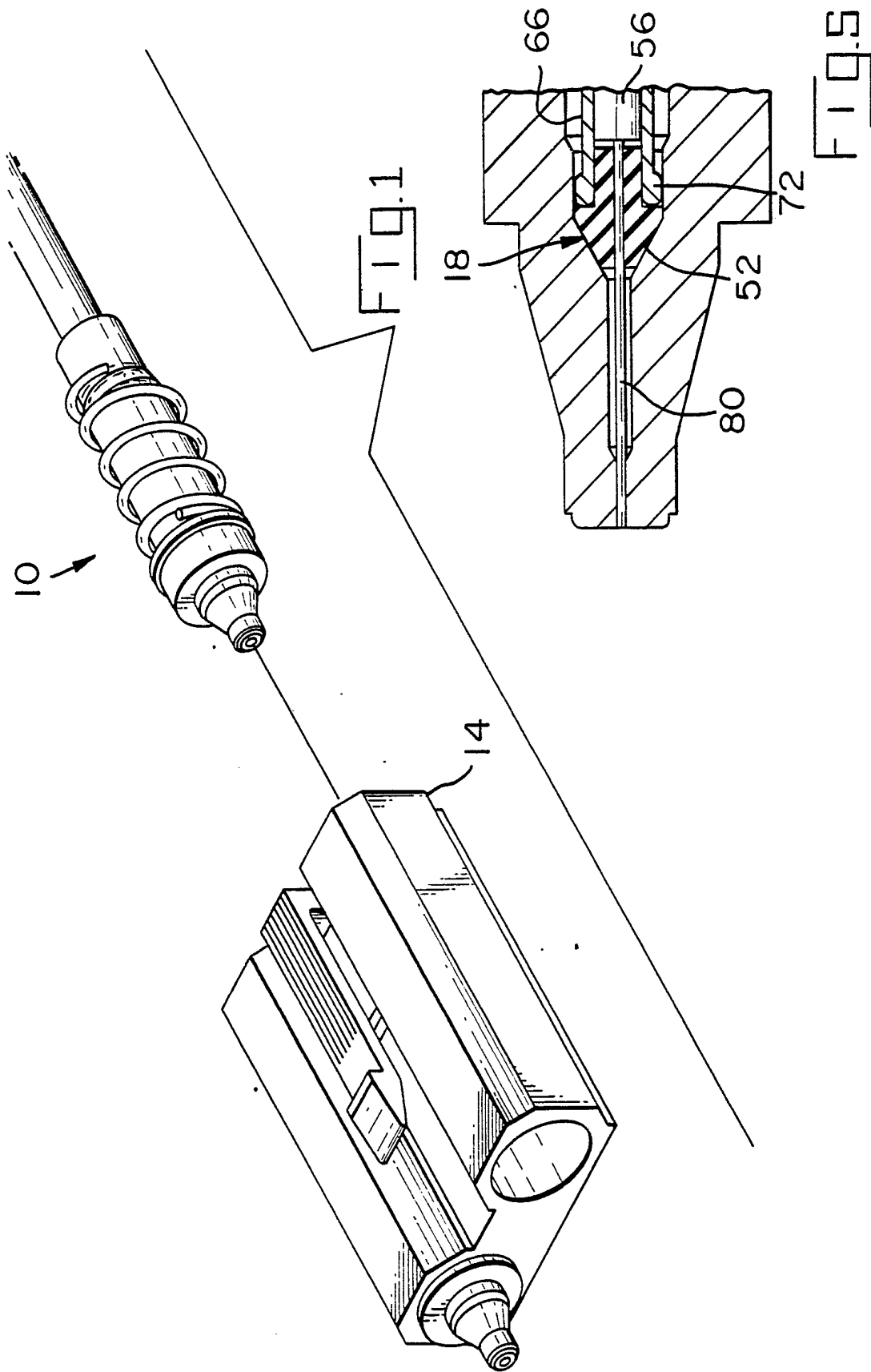

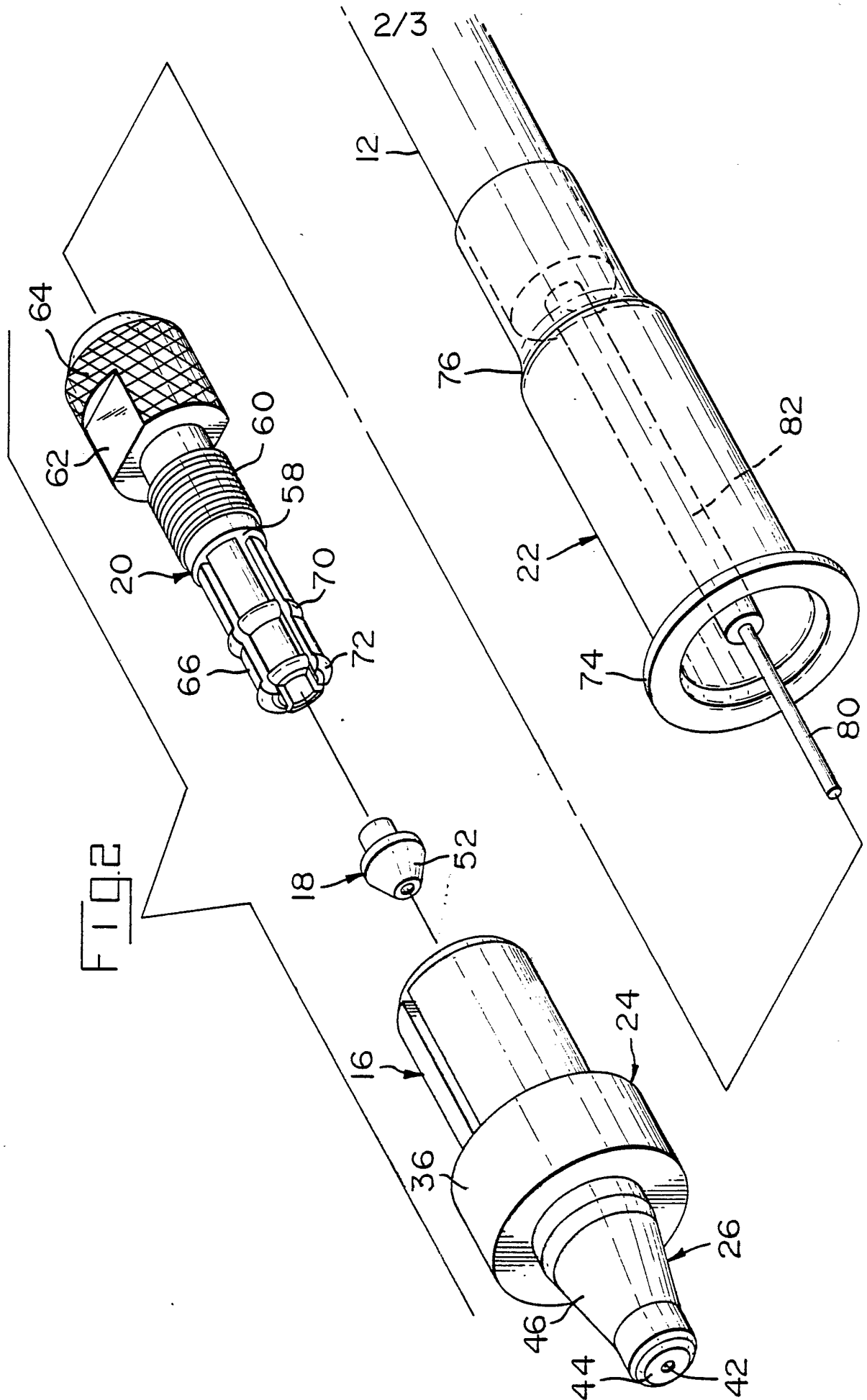

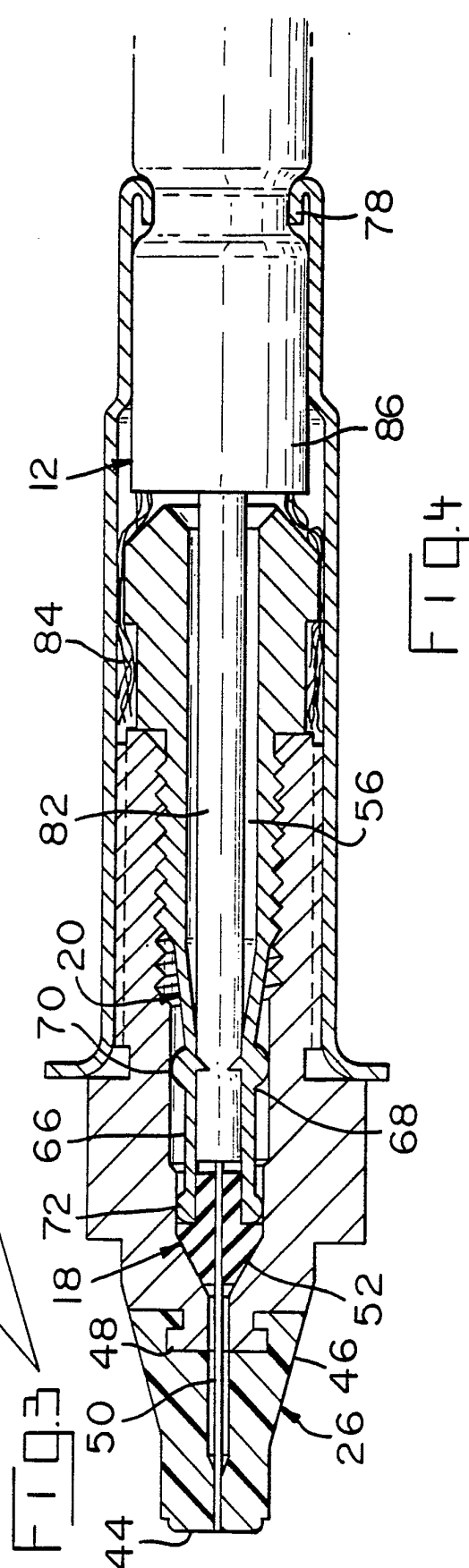
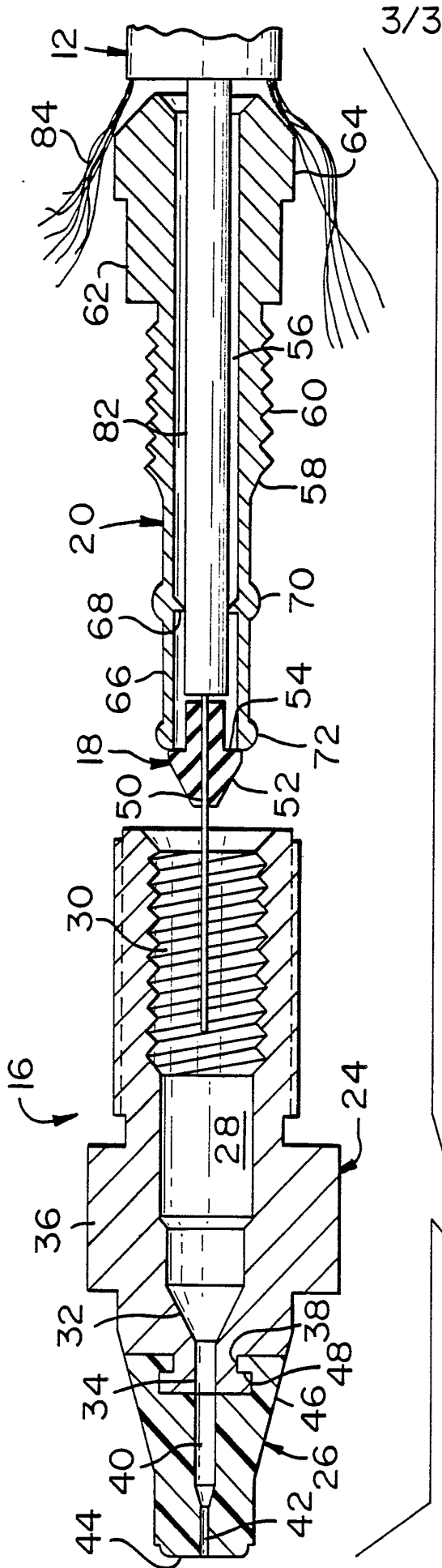

INTERNATIONAL SEARCH REPORT

International Application No PCT/US 85/01625

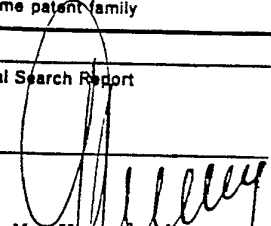
I. CLASSIFICATION OF SUBJECT MATTER (if several classification symbols apply, indicate all) ⁶		
According to International Patent Classification (IPC) or to both National Classification and IPC		
IPC ⁴ : G 02 B 6/38		
II. FIELDS SEARCHED		
Minimum Documentation Searched ⁷		
Classification System	Classification Symbols	
IPC ⁴	G 02 B	
Documentation Searched other than Minimum Documentation to the Extent that such Documents are Included in the Fields Searched ⁸		
III. DOCUMENTS CONSIDERED TO BE RELEVANT⁹		
Category ⁹	Citation of Document, ¹¹ with indication, where appropriate, of the relevant passages ¹²	Relevant to Claim No. ¹³
A	US, A, 3946467 (LUKAS et al.) 30 March 1976, see figures 4,11,12,17; column 1, lines 38-48; column 2, line 22 - column 3, line 26 (cited in the application) ---	1,4,5,7
A	GB, A, 2040062 (LEE GREEN PRECISION INDUS- TRIES LTD.) 20 August 1980, see page 2, lines 10-26,36-47; figure 1 ---	1-3
A	Patents Abstracts of Japan, volume 2, nr. 4, 12 January 1978, & JP, A, 52119237 (HITACHI) 10 June 1977, see abstract; figures -----	5,7
<p>¹⁰ Special categories of cited documents:</p> <p>"A" document defining the general state of the art which is not considered to be of particular relevance</p> <p>"E" earlier document but published on or after the international filing date</p> <p>"L" document which may throw doubts on priority claim(s) or which is cited to establish the publication date of, another citation or other special reason (as specified)</p> <p>"O" document referring to an oral disclosure, use, exhibition or other means</p> <p>"P" document published prior to the international filing date but later than the priority date claimed</p> <p>"T" later document published after the international filing date or priority date and not in conflict with the application but cited to understand the principle or theory underlying the invention</p> <p>"X" document of particular relevance; the claimed invention cannot be considered novel or cannot be considered to involve an inventive step</p> <p>"Y" document of particular relevance; the claimed invention cannot be considered to involve an inventive step when the document is combined with one or more other such documents, such combination being obvious to a person skilled in the art.</p> <p>"Δ" document member of the same patent family</p>		
IV. CERTIFICATION		
Date of the Actual Completion of the International Search	Date of Mailing of this International Search Report	
27th November 1985	18 DEC. 1985	
International Searching Authority	Signature of Authorized Officer	
EUROPEAN PATENT OFFICE	 G.L.M. Kruidenberg	

ANNEX TO THE INTERNATIONAL SEARCH REPORT ON

INTERNATIONAL APPLICATION NO. PCT/US 85/01625 (SA 10591)

This Annex lists the patent family members relating to the patent documents cited in the above-mentioned international search report. The members are as contained in the European Patent Office EDP file on 09/12/85

The European Patent Office is in no way liable for these particulars which are merely given for the purpose of information.

Patent document cited in search report	Publication date	Patent family member(s)	Publication date
US-A- 3946467	30/03/76	None	
-----	-----	-----	-----
GB-A- 2040062	20/08/80	None	
-----	-----	-----	-----

For more details about this annex :
see Official Journal of the European Patent Office, No. 12/82