

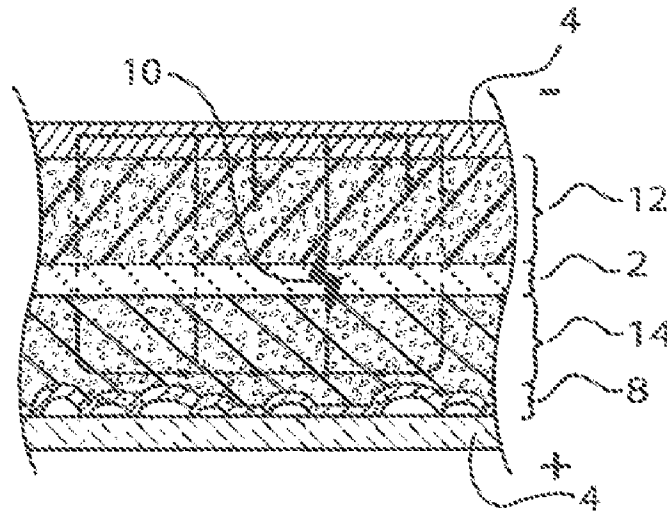

(86) Date de dépôt PCT/PCT Filing Date: 2015/11/25
 (87) Date publication PCT/PCT Publication Date: 2016/06/02
 (45) Date de délivrance/Issue Date: 2023/07/04
 (85) Entrée phase nationale/National Entry: 2017/05/24
 (86) N° demande PCT/PCT Application No.: US 2015/062767
 (87) N° publication PCT/PCT Publication No.: 2016/086184
 (30) Priorités/Priorities: 2014/11/25 (US62/084,454);
 2015/02/09 (US62/114,001); 2015/02/09 (US62/114,006);
 2015/02/09 (US62/114,007); 2015/02/10 (US62/114,508);
 2015/05/15 (US14/714,160)

(51) Cl.Int./Int.Cl. *H01M 50/581* (2021.01),
H01M 10/42 (2006.01)
 (72) Inventeurs/Inventors:
 FAN, JIANG, US;
 WU, DENG GUO, US
 (73) Propriétaire/Owner:
 AMERICAN LITHIUM ENERGY CORPORATION, US
 (74) Agent: SMART & BIGGAR LP

(54) Titre : BATTERIE RECHARGEABLE AVEC LIMITEUR DE COURANT INTERNE ET INTERRUPTEUR
 (54) Title: RECHARGEABLE BATTERY WITH INTERNAL CURRENT LIMITER AND INTERRUPTER



(57) Abrégé/Abstract:

A high energy density rechargeable (HEDR) battery employs a combined current limiter/ current interrupter to prevent thermal runaway in the event of internal discharge or other disruption of the separator. The combined current limiter/ current interrupter is interior to the battery.

(12) INTERNATIONAL APPLICATION PUBLISHED UNDER THE PATENT COOPERATION TREATY (PCT)

(19) World Intellectual Property
Organization
International Bureau(43) International Publication Date
2 June 2016 (02.06.2016)(10) International Publication Number
WO 2016/086184 A1

(51) International Patent Classification:

H01M 10/42 (2006.01) *H01M 4/62* (2006.01)
H01M 2/34 (2006.01) *H01M 4/66* (2006.01)
H01M 4/13 (2010.01) *H01M 10/0525* (2010.01)
H01M 4/36 (2006.01) *H01M 10/058* (2010.01)

(21) International Application Number:

PCT/US2015/062767

(22) International Filing Date:

25 November 2015 (25.11.2015)

(25) Filing Language:

English

(26) Publication Language:

English

(30) Priority Data:

62/084,454	25 November 2014 (25.11.2014)	US
62/114,001	9 February 2015 (09.02.2015)	US
62/114,006	9 February 2015 (09.02.2015)	US
62/114,007	9 February 2015 (09.02.2015)	US
62/114,508	10 February 2015 (10.02.2015)	US
14/714,160	15 May 2015 (15.05.2015)	US

(74) Agents: VAN LOY, Michael, D. et al.; Mintz Levin Cohn Ferris Glovsky And Popeo, P.C., 3580 Carmel Mountain Road, Suite 300, San Diego, CA 92130-6768 (US).

(81) Designated States (*unless otherwise indicated, for every kind of national protection available*): AE, AG, AL, AM, AO, AT, AU, AZ, BA, BB, BG, BH, BN, BR, BW, BY, BZ, CA, CH, CL, CN, CO, CR, CU, CZ, DE, DK, DM, DO, DZ, EC, EE, EG, ES, FI, GB, GD, GE, GH, GM, GT, HN, HR, HU, ID, IL, IN, IR, IS, JP, KE, KG, KN, KP, KR, KZ, LA, LC, LK, LR, LS, LU, LY, MA, MD, ME, MG, MK, MN, MW, MX, MY, MZ, NA, NG, NI, NO, NZ, OM, PA, PE, PG, PH, PL, PT, QA, RO, RS, RU, RW, SA, SC, SD, SE, SG, SK, SL, SM, ST, SV, SY, TH, TJ, TM, TN, TR, TT, TZ, UA, UG, US, UZ, VC, VN, ZA, ZM, ZW.(84) Designated States (*unless otherwise indicated, for every kind of regional protection available*): ARIPO (BW, GH, GM, KE, LR, LS, MW, MZ, NA, RW, SD, SL, ST, SZ, TZ, UG, ZM, ZW), Eurasian (AM, AZ, BY, KG, KZ, RU, TJ, TM), European (AL, AT, BE, BG, CH, CY, CZ, DE, DK, EE, ES, FI, FR, GB, GR, HR, HU, IE, IS, IT, LT, LU, LV, MC, MK, MT, NL, NO, PL, PT, RO, RS, SE, SI, SK, SM, TR), OAPI (BF, BJ, CF, CG, CI, CM, GA, GN, GQ, GW, KM, ML, MR, NE, SN, TD, TG).

(71) Applicant: AMERICAN LITHIUM ENERGY CORPORATION [US/US]; 1485 Poinsettia Avenue, Suite 118, Vista, CA 92081 (US).

(72) Inventors: FAN, Jiang; 1485 Poinsettia Avenue, Suite 118, Vista, CA 92081 (US). WU, Dengguo; 1485 Poinsettia Avenue, Suite 118, Vista, CA 92081 (US).

Published:

— with international search report (Art. 21(3))

[Continued on next page]

(54) Title: RECHARGABLE BATTERY WITH INTERNAL CURRENT LIMITER AND INTERRUPTER

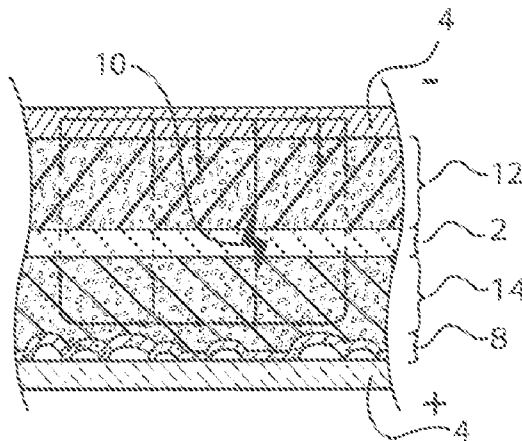

Shorted

FIG. 6D

(57) Abstract: A high energy density rechargeable (HEDR) battery employs a combined current limiter/ current interrupter to prevent thermal runaway in the event of internal discharge or other disruption of the separator. The combined current limiter/ current interrupter is interior to the battery.

WO 2016/086184 A1 

— *with amended claims (Art. 19(1))*

RECHARGEABLE BATTERY WITH INTERNAL CURRENT LIMITER AND INTERRUPTER

CROSS-REFERENCE TO RELATED APPLICATIONS

[001] This application claims priority to the following five Provisional Applications: U.S. Provisional Application no. 62/084,454, filed November 25, 2014, titled “Battery Safety Device;” U.S. Provisional Application no. 62/114,001, filed February 9, 2015, titled “Rechargeable Battery with Resistive Layer for Enhanced Safety;” U.S. Provisional Application no. 62/114,006, filed February 9, 2015, titled “Rechargeable Battery with Temperature Activated Current Interrupter;” U.S. Provisional Application no. 62/114,007, filed February 9, 2015, titled “Rechargeable Battery with Voltage Current Interrupter;” and U.S. Provisional Application no. 62/114,508, filed February 10, 2015, titled “Rechargeable Battery with Internal Current Limiter and Interrupter;” as well as to U.S. Patent Application no. 14/714,160, filed May 15, 2015, titled “Rechargeable Battery With Internal Current Limiter And Interrupter.”

BACKGROUND

Technical Field

[002] This disclosure relates to an internal current limiter or current interrupter used to protect a battery in the event of an internal short circuit or overcharge leads to thermal runaway. In particular, it relates to a high energy density rechargeable (HEDR) battery with improved safety.

Background

[003] There is a need for rechargeable battery systems with enhanced safety which have a high energy density and hence are capable of storing and delivering large amounts of electrical energy per unit volume and/or weight. Such stable high energy battery systems have significant utility in a number of applications including military equipment, communication equipment, and robotics.

[004] An example of a high energy density rechargeable (HEDR) battery commonly in use is the lithium-ion battery.

[005] A lithium-ion battery is a rechargeable battery wherein lithium ions move from the negative electrode to the positive electrode during discharge and back when charging. Lithium-ion batteries can be dangerous under some conditions and can pose a safety hazard. The fire energy content (electrical + chemical) of lithium cobalt- oxide cells is about 100 to 150 kJ per A-h, most of it chemical. If overcharged or overheated, Li-ion batteries may suffer thermal runaway and cell rupture. In extreme cases this can lead to combustion. Also, short-circuiting the battery, either externally or internally, will cause the battery to overheat and possibly to catch fire.

Overcharge:

[006] In a lithium-ion battery, useful work is performed when electrons flow through a closed external circuit. However, in order to maintain charge neutrality, for each electron that flows through the external circuit, there must be a corresponding lithium ion that is transported from one electrode to the other. The electric potential driving this transport is achieved by oxidizing a transition metal. For example, cobalt (Co), from Co^{3+} to Co^{4+} during charge and reduced from Co^{4+} to Co^{3+} during discharge. Conventionally, $\text{Li}_{1-\chi}\text{CoO}_2$ may be employed, where the coefficient χ represents the molar fraction of both the Li ion and the oxidative state of CoO_2 , viz., Co^{3+} or Co^{4+} . Employing these conventions, the positive electrode half-reaction for the lithium cobalt battery is represented as follows:

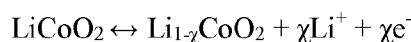

The negative electrode half reaction is represented as follows:

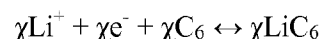

The cobalt electrode reaction is reversible limited to $x < 0.5$, limiting the depth of discharge allowable because of cycle life considerations and the stability of LiCoO_2 .

Overcharge leads to the synthesis of cobalt (IV) oxide, as follows:

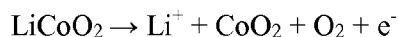

LiCoO_2 will decompose into CoO_2 and release a large amount of heat and oxygen. The released oxygen will then oxidize the electrolyte, which will lead to thermal runaway. This process is irreversible. Therefore, what is needed is some device or design that can decompose below or before positive decomposition. This device will protect the cell from thermal runaway.

Thermal Runaway:

[007] If the heat generated by a lithium ion battery exceeds its heat dissipation capacity, the battery can become susceptible to thermal runaway, resulting in overheating and, under some circumstances, to destructive results such as fire or violent explosion. Thermal runaway is a positive feedback loop wherein an increase in temperature changes the system so as to cause further increases in temperature. The excess heat can result from battery mismanagement, battery defect, accident, or other causes. However, the excess heat generation often results from increased joule heating due to excessive internal current or from exothermic reactions between the positive and negative electrodes. Excessive internal current can result from a variety of causes, but a lowering of the internal resistance due to separator short circuit caused by the factors such as conductive particles spearing through the separator is one possible cause. Heat resulting from a separator short circuit can cause a further breach within the separator, leading to a mixing of the reagents of the negative and positive electrodes and the generation of further heat due to the resultant exothermic reaction.

Internal short circuit:

[008] Lithium ion batteries employ a separator between the negative and positive electrodes to electrically separate the two electrodes from one another while allowing lithium ions to pass through. When the battery performs work by passing electrons through an external circuit, the permeability of the separator to lithium ions enables the battery to close the circuit. Short circuiting the separator by providing a conductive path across it allows the battery to discharge rapidly. A short circuit across the separator can result from improper charging and discharging or cell manufacturing defects such as metal impurities and metal shard formation during electrode production. More particularly, improper charging can lead to the deposition of metallic lithium dendrites on the surface of the negative electrode and these dendrites grow to penetrate the separator through the nanopores so as to provide a conductive path for electrons from one electrode to the other. In addition, improper discharge at or below 1.5V will cause copper dissolution which can ultimately lead to the formation of metallic copper dendrites on the surface of the negative electrode which can also grow to penetrate the separator through the nanopore. The lower resistance of these conductive paths allows for rapid discharge and the generation of significant joule heat. Overheating and thermal runaway can result.

[009] What was needed was a combination internal current limiter and current interrupter that could, at first, limit the rate of internal discharge resulting from

an internal short circuit so as to reduce the generation of Joule heat, if the rate of internal discharge is insufficiently limited, could also interrupt the internal short circuit to further curtail the rate of internal discharge, regardless of the temperature increase, so as to avert fire and/or explosion.

SUMMARY

[010] In a first aspect, provided in some implementations herein is an improved high energy density rechargeable (HEDR) battery of a type including two electrodes of opposite polarity, each electrode characterized by its resistivity, by its safe operating temperature range, and its safe charging voltage; and a separator for separating the two electrodes and preventing internal discharge therebetween. The HEDR battery includes at least one electrode employing a current collector for transferring electrons, with the separator being subject to a risk of forming a short circuit, the short circuit potentially allowing a rapid internal discharge between the two electrodes, the rapid internal discharge between the two electrodes potentially allowing a rapid production of joule heat therefrom, the rapid production of joule heat potentially allowing a thermal runaway. In the HEDR battery, the two electrodes can be subject to a risk of overcharge above the safe charging voltage and the formation of the short circuit therefrom and the two electrodes can be subject to a risk of thermal runaway above the safe operating temperature range. The HEDR battery can include an improvement for slowing the rate of internal discharge resulting from the short circuit, for slowing the production of joule heat therefrom, and for reducing the risk of thermal runaway, the improvement includes: a current limiter forming an electrical coupling between one of the electrodes and its corresponding current collector, the current limiter having a resistivity for resistively impeding current therethrough and, in the event the separator forms the short circuit, for diverting current from the electrode current collector to which it is coupled, and for reducing the rate of the internal discharge between the two electrodes; and a current interrupter having an engaged configuration, an disengaged configuration, and a gas generating component for transitioning the current interrupter from the engaged to the unengaged configuration. The gas generating component can have a trigger for generating a gas, the trigger being selected from the group consisting of temperature triggers and voltage triggers, and the temperature triggers can be activatable above the safe operating temperature range. The voltage triggers can be activatable above the safe charging voltage in the engaged configuration, the current interrupter electrically coupling one of the electrodes and its corresponding current collector with a laminated connection, and in the disengaged

configuration, the laminated connection becoming delaminated and the current interrupter forming a nonconductive gap for interrupting the electrical coupling between the electrode and its corresponding current collector. The current interrupter transitions from the engaged to the disengaged configuration by triggering the gas generating component responsive to the trigger, the generated gas delaminating the laminated connection for interrupting the electrical coupling between the electrode and its corresponding current collector. The current limiter and the current interrupter, in combination, diminish the risk of thermal runaway resulting from separator short circuit, electrode overcharge, and electrode overheating.

[011] The following features can be present in the improved high energy density rechargeable (HEDR) battery in any suitable combination. The current limiter and the current interrupter can be simultaneously incorporated into a protective layer interposed by lamination between the same electrode and current collector. The HEDR battery can include two current collectors, including a first current collector and a second current collector, the two electrodes including a first electrode and a second electrode, and the first electrode including a first portion and a second portion, the second portion of the first electrode interposed between the first portion of the first electrode and the first current collector, the improvement further characterized in which: the current limiter being layered between the first portion of the first electrode and the second portion of the first electrode; and the current interrupter being layered between the second portion of the first electrode and the first current collector. The current limiter can be layered between the second portion of the first electrode and the first current collector, and the current interrupter can be layered between the first portion of the first electrode and the second portion of the first electrode. The HEDR battery can have two current collectors, including a first current collector and a second current collector and the two electrodes including a first electrode and a second electrode, and the current limiter can be layered between the first electrode and the first current collector; and the current interrupter can be layered between the second electrode and the second current collector. In the HEDR battery, each electrode can have a temperature range for safe operation and an internal resistivity therein, and the current limiter can have a resistivity greater than the internal resistivity of the electrode with which the current limiter is layered within the temperature range for safe operation. The current limiter can lack a resistivity transition switch at temperatures within the temperature range for safe operation. The HEDR battery can be such that each electrode has a temperature range for standard operation and the current limiter can have a resistivity transition with a resistivity less than the internal resistivity of the electrode within the temperature range for standard

operation and a resistivity greater than the internal resistivity of the electrode above the temperature range for standard operation. The HEDR battery can be such that each electrode has a temperature range for standard operation and the current interrupter can be activated by temperature above the temperature range for standard operation. In some implementations, the HEDR battery can be of a type in which each electrode has a temperature range for standard operation and a temperature range for safe operation, in which the current interrupter can be activated by temperature above the temperature range for standard operation and within the temperature range for safe operation. In some implementations, the HEDR battery can be such that each electrode has an internal resistivity within the temperature range for safe operation, in which the current limiter can have a resistivity greater than the internal resistivity of the electrode with which the current limiter is layered within the temperature range for safe operation. The current limiter and the current interrupter can be simultaneously incorporated into a protective layer interposed by lamination between the same electrode and current collector. The HEDR battery can be of a type in which each electrode has a voltage range for standard operation, and in which the current interrupter is activated by voltage above the voltage range for standard operation. The HEDR battery can be of a type in which each electrode has a voltage range for standard operation and a voltage range for safe operation, and in which the current interrupter is activated by voltage above the voltage range for standard operation and within the voltage range for safe operation. The current limiter and the current interrupter can be simultaneously incorporated into a protective layer interposed by lamination between the same electrode and current collector.

[012] In a related aspect, provided herein is an improved high energy density rechargeable battery of a type including two electrodes of opposite polarity, a separator separating the two electrodes, and at least one current collector electrically coupled to one of the electrodes, the separator preventing internal discharge between the two electrodes, failure of the separator potentially causing an internal discharge between the two electrodes, the internal discharge causing a generation of joule heat of potential danger, that includes a thermally activatable current interrupter and a voltage activatable current interrupter. The thermally activatable current interrupter can be layered by lamination between one of the current collectors and one of the electrodes, the thermally activatable current interrupter, when unactivated, electrically coupling the current collector to the electrode with which it is layered, the current interrupter, when activated, delaminating from the current collector for forming a nonconductive gap for electrically decoupling the

current collector from the electrode with which it had been layered, the electrical decoupling slowing the rate of internal discharge between the two electrodes in the event of separator failure. The voltage activatable current interrupter can be layered by lamination between one of the current collectors and one of the electrodes, the voltage activatable current interrupter, when unactivated, electrically coupling the current collector to the electrode with which it is layered, the current interrupter, when activated, delaminating from the current collector for forming a nonconductive gap for electrically decoupling the current collector from the electrode with which it had been layered, the electrical decoupling slowing the rate of internal discharge between the two electrodes in the event of separator failure. In the HEDR battery, the activation of either the thermally activated current interrupter or voltage activated current interrupter in the event of separator failure, can slow the generation joule heat for diminishing the potential danger.

[013] In a further related aspect, provided in some implementations herein is a process for avoiding thermal runaway within a high energy density rechargeable battery undergoing internal discharge due to separator failure, that includes delaminating an electrode within the battery from its current collector by generating a gas from a heat sensitive gas generating material within an interrupt layer interposed between the electrode and current collector, the delaminating electrically decoupling the electrode from its current collector for slowing the rate of internal discharge.

[014] In a first aspect, provided herein is a high energy density rechargeable (HEDR) battery that includes an anode energy layer, a cathode energy layer, a separator between the anode energy layer and the cathode energy layer for preventing internal discharge thereof, at least one current collector for transferring electrons to and from either the anode or cathode energy layer, the anode and cathode energy layers each having an internal resistivity, the HEDR battery having a preferred temperature range for discharging electric current and an upper temperature safety limit; and a resistive layer interposed between the separator and one of the current collectors, the resistive layer configured to limit the rate of internal discharge through the separator in the event of separator failure and the generation of joule heat resulting therefrom, the resistive layer having a fixed resistivity at temperatures between the preferred temperature range and the upper temperature safety limit, the fixed resistivity of the resistive layer being greater than the internal resistivity of either energy layer, the resistive layer for avoiding temperatures in excess of the upper temperature safety limit in the event of separator failure.

[015] The following features can be included in the HEDR battery in any suitable combination. In some implementations, the resistive layer of the HEDR battery can be porous and include a ceramic powder defining an interstitial space, a binder for partially filling the interstitial space for binding the ceramic powder; and a conductive component dispersed within the binder for imparting resistivity to the resistive layer, the interstitial space remaining partially unfilled for imparting porosity and permeability to the resistive layer. The resistive layer can be compressed to reduce the unfilled interstitial space and increase the binding of the ceramic powder by the binder. The resistive layer can include greater than 30 % ceramic powder by weight. The resistive layer can include greater than 50 % ceramic powder by weight. The resistive layer can include greater than 70 % ceramic powder by weight. The resistive layer can include greater than 75 % ceramic powder by weight. The resistive layer can include greater than 80 % ceramic powder by weight. The resistive layer of the HEDR battery can be permeable to transport of ionic charge carriers. The resistive layer can be non-porous and have a composition that includes a non-conductive filler, a binder for binding the non-conductive filler, and a conductive component dispersed within the binder for imparting resistivity to the resistive layer. The resistive layer can be impermeable to transport of ionic charge carriers. The fixed resistivity of the resistive layer of the HEDR battery can be at least twice as great as the internal resistivity of either energy layer. The fixed resistivity of the resistive layer can be at least five times as great as the internal resistivity of either energy layer. The fixed resistivity of the resistive layer can be at least ten times as great as the internal resistivity of either energy layer. The resistive layer can lack a transformation from solid phase to non-solid phase for transforming the resistivity of the resistive layer from low resistivity to high resistivity at temperatures between the maximum operating temperature and the upper temperature safety limit. The resistive layer can be non-sacrificial at temperatures below the upper temperature safety limit. The resistive layer can be sacrificial at temperatures above the upper temperature safety limit. The resistive layer can include a ceramic powder that chemically decomposes above the upper temperature safety limit for evolving a fire retardant gas. The resistive layer can include a ceramic powder that chemically decomposes above the upper temperature safety limit for evolving a gas for delaminating the current collector from the resistive layer. The current collector can include an anode current collector for transferring electrons to and from the anode energy layer, wherein the resistive layer is interposed between the separator and the anode current collector. The resistive layer can be interposed between the anode current collector and the anode energy layer. The resistive layer can be interposed between the anode

energy layer and the separator. In some implementations, the anode energy layer of the HEDR battery can include a first anode energy layer, and a second anode energy layer interposed between the first anode energy and the separator, wherein the resistive layer is interposed between the first anode energy layer and the second anode energy layer. The current collector can include a cathode current collector for transferring electrons to and from the cathode energy layer, wherein the resistive layer is interposed between the separator and the cathode current collector. The resistive layer can be interposed between the cathode current collector and the cathode energy layer. The resistive layer can be interposed between the cathode energy layer and the separator. The cathode energy layer can include a first cathode energy layer, and a second cathode energy layer interposed between the first cathode energy and the separator, wherein the resistive layer is interposed between the first cathode energy layer and the second cathode energy layer. In some implementations, the HEDR battery can include two current collectors that include an anode current collector for transferring electrons to and from the anode energy layer, and a cathode current collector for transferring electrons to and from the cathode energy layer in which the resistive layer comprises an anode resistive layer and a cathode resistive layer, the anode resistive layer interposed between the separator and the anode current collector, the cathode resistive layer interposed between the separator and the cathode current collector.

[016] In a related aspect, provided herein is a method for limiting the rate of an internal discharge of energy layers resulting from a separator failure within a high energy density rechargeable (HEDR) battery, the method that includes resisting the internal discharge with a resistive layer, the resistive layer being interposed between a separator and a current collector within the HEDR battery, the resistive layer having a fixed resistivity at temperatures between a preferred temperature range for discharging the energy layers and an upper temperature safety limit, the fixed resistivity of the resistive layer being greater than the internal resistivity of the energy layers.

[017] Provided in some embodiments herein is a high energy density rechargeable (HEDR) metal-ion battery that includes an anode energy layer, a cathode energy layer, a separator for separating the anode energy layer from the cathode energy layer, at least one current collector for transferring electrons to and from either the anode or cathode energy layer, the high energy density rechargeable metal-ion battery having an upper temperature safety limit for avoiding thermal runaway, and an interrupt layer activatable for interrupting current within high energy density rechargeable metal-ion battery upon exposure to temperature at or above the upper temperature safety limit, the interrupt layer interposed

between the separator and one of the current collectors, the interrupt layer, when unactivated, being laminated between the separator and one of the current collectors for conducting current therethrough, the interrupt layer, when activated, being delaminated for interrupting current through the high energy density rechargeable metal-ion battery, the interrupt layer including a temperature sensitive decomposable component for decomposing upon exposure to temperature at or above the upper temperature safety limit, the temperature sensitive decomposable component for evolving a gas upon decomposition, the evolved gas for delaminating the interrupt layer for interrupting current through the high energy density metal-ion battery, in which the high energy density rechargeable metal-ion battery avoids thermal runaway by activation of the interrupt layer upon exposure to temperature at or above the upper temperature safety limit for interrupting current in high energy density rechargeable metal-ion battery.

[018] The following features can be present in the HEDR metal-ion battery in any suitable combination. The interrupt layer can be porous. The temperature sensitive decomposable component can include a ceramic powder. The interrupt layer can have a composition comprising the ceramic powder, a binder, and a conductive component. The ceramic powder can define an interstitial space. The binder can partially fill the interstitial space for binding the ceramic powder. The conductive component can be dispersed within the binder for imparting conductivity to the interrupt layer. The interstitial space can remain partially unfilled for imparting porosity and permeability to the interrupt layer. The interrupt layer can include greater than 30% ceramic powder by weight. The interrupt layer can include greater than 50% ceramic powder by weight. The interrupt layer can include greater than 70% ceramic powder by weight. The interrupt layer can include greater than 75% ceramic powder by weight. The interrupt layer can include greater than 80% ceramic powder by weight. The interrupt layer can be permeable to transport of ionic charge carriers. The interrupt layer can be non-porous and have a composition that includes a non-conductive filler, a binder for binding the non-conductive filler, and a conductive component dispersed within the binder for imparting conductivity to the interrupt layer. The interrupt layer can be impermeable to transport of ionic charge carriers. The interrupt layer can be sacrificial at temperatures above the upper temperature safety limit. The interrupt layer can include a ceramic powder that chemically decomposes above the upper temperature safety limit for evolving a fire retardant gas. The current collector can include an anode current collector for transferring electrons to and from the anode energy layer, wherein the interrupt layer being interposed between the separator and the anode current collector. The interrupt layer can be

interposed between the anode current collector and the anode energy layer. The interrupt layer can be interposed between the anode energy layer and the separator. The anode energy layer of the HEDR battery can include a first anode energy layer; and a second anode energy layer interposed between the first anode energy and the separator, wherein the interrupt layer being interposed between the first anode energy layer and the second anode energy layer. The current collector can include a cathode current collector for transferring electrons to and from the cathode energy layer, wherein the interrupt layer is interposed between the separator and the cathode current collector. The interrupt layer can be interposed between the cathode current collector and the cathode energy layer. The interrupt layer can be interposed between the cathode energy layer and the separator. The cathode energy layer can include a first cathode energy layer and a second cathode energy layer interposed between the first cathode energy and the separator, wherein the interrupt layer is interposed between the first cathode energy layer and the second cathode energy layer. The HEDR battery can further include two current collectors that include an anode current collector for transferring electrons to and from the anode energy layer and a cathode current collector for transferring electrons to and from the cathode energy layer, in which the interrupt layer includes an anode interrupt layer and a cathode interrupt layer, the anode interrupt layer interposed between the separator and the anode current collector, the cathode interrupt layer interposed between the separator and the cathode current collector.

[019] In a related aspect, a method is presented for interrupting current within a high energy density rechargeable metal-ion battery upon exposure to temperature at or above an upper temperature safety limit for avoiding thermal runaway, that includes: raising the temperature of the high energy density rechargeable metal-ion battery above the upper temperature safety limit, and activating the interrupt layer for interrupting current through the high energy density metal-ion battery. The high energy density rechargeable metal-ion battery can include: an anode energy layer; a cathode energy layer; a separator separating the anode energy layer from the cathode energy layer; a current collector for transferring electrons to and from either the anode or cathode energy layer; and an interrupt layer, the interrupt layer interposed between the separator and one of the current collectors, the interrupt layer, when unactivated, being laminated between the separator and one of the current collectors for conducting current therethrough, the interrupt layer, when activated, being delaminated for interrupting current through the lithium ion battery, the interrupt layer comprising a temperature sensitive decomposable component for decomposing upon exposure to temperature at or above the upper temperature safety limit, the temperature

sensitive decomposable component for evolving a gas upon decomposition, the evolved gas for delaminating the interrupt layer for interrupting current through the high energy density metal-ion battery; whereby thermal runaway by the high energy density rechargeable metal-ion battery is avoided by interruption of current therethrough.

[020] Provided in some implementations herein is a high energy density rechargeable (HEDR) metal-ion battery that includes an anode energy layer, a cathode energy layer, a separator for separating the anode energy layer from the cathode energy layer, an anode current collector for transferring electrons to and from the anode energy layer, the high energy density rechargeable metal-ion battery being rechargeable and characterized by a maximum safe voltage for avoiding overcharge; and an interrupt layer activatable for interrupting current within the high energy density rechargeable battery upon exposure to voltage in excess of the maximum safe voltage, the interrupt layer sandwiched between the cathode energy layer and the cathode current collector, the interrupt layer, when unactivated, being laminated to the anode current collector for conducting current therethrough, the interrupt layer, when activated, being delaminated from the anode current collector for interrupting current therethrough, the interrupt layer including a voltage sensitive decomposable component for decomposing upon exposure to voltage in excess of the maximum safe voltage, the voltage sensitive decomposable component for evolving a gas upon decomposition, the evolved gas for delaminating the interrupt layer from the anode current collector for interrupting current therethrough, whereby the high energy density rechargeable metal-ion battery avoids overcharge by activation of the interrupt layer upon exposure to voltage in excess of the maximum safe voltage for interrupting current therethrough.

[021] The following features can be present in the high energy density rechargeable metal-ion battery in any suitable combination. The interrupt layer of the HEDR battery can be porous and have a composition that includes a ceramic powder defining an interstitial space; a binder for partially filling the interstitial space for binding the ceramic powder; and a conductive component dispersed within the binder for imparting conductivity to the interrupt layer, the interstitial space remaining partially unfilled for imparting porosity and permeability to the interrupt layer. The interrupt layer can be compacted for reducing the unfilled interstitial space and increasing the binding of the ceramic powder by the binder. The interrupt layer can include greater than 30% ceramic powder by weight. The interrupt layer can include greater than 50% ceramic powder by weight. The interrupt layer can include greater than 70% ceramic powder by weight. The interrupt layer can include greater

than 75% ceramic powder by weight. The interrupt layer can include greater than 80% ceramic powder by weight. The interrupt layer can be permeable for transporting ionic charge carriers. The interrupt layer of the HEDR battery can be non-porous and have a composition that includes a non-conductive filler; a binder for binding the non-conductive filler; and a conductive component dispersed within the binder for imparting conductivity to the interrupt layer. The interrupt layer can be impermeable to transport of ionic charge carriers. The interrupt layer can be sacrificial at voltages above the maximum safe voltage for recharging. The interrupt layer can include a ceramic powder that chemically decomposes above maximum safe voltage for evolving the gas. The gas can be fire retardant.

[022] In a related aspect, provided herein is a method for interrupting a recharging process for a high energy density rechargeable metal-ion battery upon exposure to voltage at or above a maximum safe voltage for avoiding overcharge, the high energy density rechargeable metal-ion battery comprising an anode energy layer, a cathode energy layer, a separator between the anode energy layer and the cathode energy layer, and an anode current collector for transferring electrons to and from the anode energy layer. The method includes overcharging the high energy density rechargeable metal-ion battery for increasing the voltage above the maximum safe voltage for recharging; and interrupting the overcharging by evolving a gas by decomposition of a voltage sensitive decomposable component within a interrupt layer laminated to the anode current collector, the evolved gas delaminating the interrupt layer from the anode current collector, whereby the overcharging of the high energy density rechargeable metal-ion battery is interrupted by evolution of gas within the interrupt layer for delaminating the interrupt layer from the anode current collector.

[023] A first aspect of the disclosure is directed to an improved high energy density rechargeable (HEDR) battery of a type including two electrodes of opposite polarity (12 and 14). Each electrode is characterized by its resistivity, by its safe operating temperature range, and its safe charging voltage. The HEDR is further of a type having a separator 2 for separating the two electrodes (12 and 14) and preventing internal discharge there between and at least one electrode (12 or 14) employing a current collector 4 for transferring electrons. The separator 2 is subject to a risk of forming a short circuit. The short circuit can potentially allow a rapid internal discharge between the two electrodes (12 and 14), potentially allowing a rapid production of joule heat therefrom, the rapid production of joule heat potentially allowing a thermal runaway. The two electrodes (12 and 14) are subject to a risk of overcharge above the safe charging voltage and the formation of

the short circuit therefrom. The two electrodes (12 and 14) are subject to a risk of thermal runaway above the safe operating temperature range.

[024] The improvement for this first aspect of the disclosure is employable for slowing the rate of internal discharge resulting from the short circuit, for slowing the production of joule heat therefrom, and for reducing the risk of thermal runaway.

[025] The improvement comprises the addition to the HEDR battery of a current limiter 6 combined with a current interrupter 8.

[026] The current limiter 6 forms an electrical coupling between one of the electrodes (12 or 14) and its corresponding current collector 4. The current limiter 6 has a resistivity for resistively impeding current therethrough and, in the event the separator 2 forms the short circuit, for diverting current from the electrode current collector 4 to which it is coupled, and for reducing the rate of the internal discharge between the two electrodes (12 and 14).

[027] The current interrupter 8 has an engaged configuration, a disengaged configuration, and a gas generating component for transitioning the current interrupter 8 from the engaged to the unengaged configuration. The gas generating component also has a trigger for generating a gas. The trigger is selected from the group consisting of temperature triggers and voltage triggers.

[028] The temperature triggers are activatable above the safe operating temperature range.

[029] The voltage triggers are activatable above the safe charging voltage.

[030] In its engaged configuration, the current interrupter 8 electrically couples one of the electrodes (12 or 14) and its corresponding current collector 4 with a laminated connection.

[031] In the disengaged configuration, the laminated connection becomes delaminated and the current interrupter 8 forms a nonconductive gap for interrupting the electrical coupling between the electrode (12 or 14) and its corresponding current collector 4.

[032] The current interrupter 8 transitions from its engaged configuration to its disengaged configuration by triggering the gas generating component responsive to the trigger. The resulting generated gas delaminates the laminated connection for interrupting the electrical coupling between the electrode (12 or 14) and its corresponding current collector 4.

[033] In this first aspect of the disclosure, the current limiter 6 and the current interrupter 8, in combination, diminishes the risk of thermal runaway resulting from separator short circuit, electrode overcharge, and electrode overheating.

[034] In one embodiment of this first aspect of the disclosure, the current limiter 6 and the current interrupter 8 are simultaneously incorporated into a protective layer interposed by lamination between the same electrode (12 or 14) and current collector 4.

[035] In another embodiment of this first aspect of the disclosure, the battery is of a type having two current collectors 4, including a first current collector 4 and a second current collector 4. The two electrodes (12 and 14) include a first electrode and a second electrode. The first electrode includes a first portion and a second portion. The second portion of the first electrode is interposed between the first portion of the first electrode and the first current collector 4. The improvement of this embodiment of the disclosure is further characterized by the current limiter 6 being layered between the first portion of the first electrode and the second portion of the first electrode; and the current interrupter 8 being layered between the second portion of the first electrode and the first current collector 4. In a sub-embodiment of this first aspect of the disclosure, the current limiter 6 is layered between the second portion of the first electrode and the first current collector 4, and the current interrupter 8 is layered between the first portion of the first electrode and the second portion of the first electrode.

[036] In another embodiment of this first aspect of the disclosure, the battery is of a type having two current collectors 4, including a first current collector 4 and a second current collector 4 and the two electrodes (12 and 14) including a first electrode and a second electrode, the improvement further characterized wherein. In this embodiment, the current limiter 6 is layered between the first electrode and the first current collector 4; and the current interrupter 8 being layered between the second electrode and the second current collector 4.

[037] In another embodiment of this first aspect of the disclosure, the battery is of a type wherein each electrode (12 or 14) has a temperature range for safe operation and an internal resistivity therein. In this embodiment, the current limiter 6 has a resistivity greater than the internal resistivity of the electrode (12 or 14) with which the current limiter 6 is layered within the temperature range for safe operation.

[038] In another embodiment of this first aspect of the disclosure, the improvement is further characterized by the current limiter 6 lacking a resistivity transition switch at temperatures within the temperature range for safe operation.

[039] In another embodiment of this first aspect of the disclosure, the battery is of a type wherein each electrode (12 and 14) has a temperature range for standard operation. In this embodiment, the current limiter 6 has a resistivity transition with a resistivity less than the internal resistivity of the electrode (12 and/or 14) within the temperature range for

standard operation and a resistivity greater than the internal resistivity of the electrode (12 and/or 14) above the temperature range for standard operation.

[040] In another embodiment of this first aspect of the disclosure, the battery is of a type wherein each electrode (12 and 14) has a temperature range for standard operation. In this embodiment, the current interrupter 8 is activated by temperature above the temperature range for standard operation.

[041] In another embodiment of this first aspect of the disclosure, the battery is of a type wherein each electrode (12 and 14) has a temperature range for standard operation and a temperature range for safe operation. In this embodiment, the current interrupter 8 is activated by temperature above the temperature range for standard operation and within the temperature range for safe operation.

[042] In another embodiment of this first aspect of the disclosure, the battery is of a type wherein each electrode (12 and 14) has an internal resistivity within the temperature range for safe operation. In this embodiment, the current limiter 6 has a resistivity greater than the internal resistivity of the electrode (12 or 14) with which the current limiter 6 is layered within the temperature range for safe operation. In an alternative to this embodiment, the current limiter 6 and the current interrupter 8 are simultaneously incorporated into a protective layer interposed by lamination between the same electrode (12 or 14) and current collector 4.

[043] In another embodiment of this first aspect of the disclosure, the battery is of a type wherein each electrode (12 and 14) has a voltage range for standard operation. In this embodiment, the current interrupter 8 is activated by voltage above the voltage range for standard operation.

[044] In another embodiment of this first aspect of the disclosure, the battery is of a type wherein each electrode (12 and 14) has a voltage range for standard operation and a voltage range for safe operation. In this embodiment, the current interrupter 8 is activated by voltage above the temperature range for standard operation and within the voltage range for safe operation. In an alternative of this embodiment, the current limiter 6 and current interrupter 8 are simultaneously incorporated into a protective layer interposed by lamination between the same electrode (12 or 14) and current collector 4.

[045] A second aspect of the disclosure is directed to another improved high energy density rechargeable battery of a type including two electrodes (12 and 14) of opposite polarity, a separator 2 separating the two electrodes (12 and 14), and at least one current collector 4 electrically coupled to one of the electrodes (12 or 14). The separator 2 prevents

internal discharge between the two electrodes (12 and 14). Failure of the separator 2 potentially causes an internal discharge between the two electrodes (12 and 14). The internal discharge causes the generation of joule heat of potential danger.

[046] The improvement for this second aspect of the disclosure comprises a thermally activatable current interrupter 8 and a voltage activatable current interrupter 8.

[047] The thermally activatable current interrupter 8 is layered by lamination between one of the current collectors 4 and one of the electrodes (12 or 14). The thermally activatable current interrupter 8, when unactivated, electrically couples the current collector 4 to the electrode (12 or 14) with which it is layered, the current interrupter 8. When activated, the thermally activatable current interrupter 8 delaminates from the current collector 4 for forming a nonconductive gap for electrically decoupling the current collector 4 from the electrode (12 or 14) with which it had been layered. The electrical decoupling serves to slow the rate of internal discharge between the two electrodes (12 and 14) in the event of separator failure.

[048] The voltage activatable current interrupter 8 is layered by lamination between one of the current collectors 4 and one of the electrodes (12 or 14). The voltage activatable current interrupter 8, when unactivated, electrically couples the current collector 4 to the electrode (12 or 14) with which it is layered. The current interrupter 8, when activated, delaminates from the current collector 4 by forming a nonconductive gap for electrically decoupling the current collector 4 from the electrode (12 or 14) with which it had been layered. The resultant electrical decoupling serves to slow the rate of internal discharge between the two electrodes (12 and 14) in the event of separator failure. In this second aspect of the disclosure, activation of either the thermally activated current interrupter 8 or the voltage activated current interrupter 8 in the event of separator failure, slows the generation joule heat for diminishing the potential danger.

[049] A second aspect of the disclosure is directed to a process for avoiding thermal runaway within a high energy density rechargeable battery undergoing internal discharge due to separator failure. The process comprises the step of delaminating an electrode (12 or 14) within the battery from its current collector 4 by generating a gas from a heat sensitive gas generating material within an interrupt layer interposed between the electrode (12 or 14) and current collector 4. The delamination electrically decouples the electrode (12 or 14) from its current collector 4 for slowing the rate of internal discharge.

[050] A third aspect of the disclosure is directed to a process for avoiding thermal runaway within a high energy density rechargeable battery at risk of suffering from

separator failure due to voltage overcharge. The process comprises the step of delaminating an electrode (12 or 14) within the battery from its current collector 4 by generating a gas from a voltage sensitive gas generating material within an interrupt layer interposed between the electrode (12 or 14) and current collector 4. The delamination electrically decouples the
5 electrode (12 or 14) from its current collector 4 for interrupting the voltage overcharge.

[051] A fourth aspect of the disclosure is directed to a process for avoiding thermal runaway within a high energy density rechargeable battery at risk of suffering from separator failure due to voltage overcharge. The process comprises the step of delaminating an electrode (12 or 14) within the battery from its current collector 4 by generating a gas from a
10 voltage or temperature sensitive material that will form the gas indirectly through its decomposition compound (at the high voltage) that will react with the battery components such as electrolyte and electrodes (12 and 14). This voltage or temperature sensitive material will be still called as gas generator, and can be within an interrupt layer interposed between the electrode (12 or 14) and current collector 4. The delamination electrically decouples the
15 electrode (12 or 14) from its current collector 4 for interrupting the voltage overcharge.

[051a] Another aspect of the disclosures is directed to an improved high energy density rechargeable battery, comprising: a first electrode; a first current collector for transferring electrons; a current interrupter layered by lamination between the first electrode and the first current collector when the current interrupter is in the engaged configuration,
20 wherein the current interrupter is configured to delaminate from the first current collector to form a nonconductive gap that electrically decouples the first electrode and the first current collector when the current interrupter is in an unengaged configuration, wherein the current interrupter comprises a heat sensitive material configured to cause, upon activation of at least a temperature trigger, a formation of a nonconductive gap between the first electrode and the
25 first current collector, wherein the forming of the nonconductive gap electrically decouples the first electrode from the first current collector and diverts current flow from the first current collector, wherein the heat sensitive material is configured to transition the current interrupter from the engaged configuration to the unengaged configuration upon activation of at least the

temperature trigger, wherein the first electrode and the first current collector are electrically coupled when the current interrupter is in the engaged configuration, and wherein the nonconductive gap is formed between the first electrode and the first current collector when the current interrupter is in the unengaged configuration; a second electrode having an
5 opposite polarity of the first electrode; and a separator interposed between the first electrode and the second electrode.

[051b] Still another aspect of the disclosures is directed to a method, comprising: forming a nonconductive gap between an electrode within a battery and a current collector, wherein the forming of the nonconductive gap is caused by a heat sensitive material in
10 response to an activation of least a temperature trigger, wherein the heat sensitive material comprises a current interrupter layered by lamination between the electrode and current collector when the current interrupter is in an engaged configuration, wherein the current interrupter is configured to delaminate from the current collector to form the nonconductive gap that electrically decouples the electrode and the current collector when the current
15 interrupter is in an unengaged configuration, wherein the forming of the nonconductive gap electrically decouples the electrode from the current collector and diverts current flow from the current collector, wherein the heat sensitive material is configured to transition the current interrupter from the engaged configuration to the unengaged configuration upon activation of at least the temperature trigger, wherein the electrode and the current collector are electrically
20 coupled when the current interrupter is in the engaged configuration, and wherein the nonconductive gap is formed between the electrode and the current collector when the current interrupter is in the unengaged configuration.

BRIEF DESCRIPTION OF DRAWINGS

[052] The present disclosure is described more fully herein with reference to the
25 accompanying drawings, in which some exemplary embodiments of the present disclosure are shown. As those skilled in the art would realize, the described embodiments may be modified in various different ways, all without departing from the spirit or scope of the present disclosure. Accordingly, the drawings and description are to be regarded as illustrative in

nature and not restrictive. In the drawings, the thicknesses of layers and regions may be exaggerated for clarity.

[053] FIGs. 1A-1G illustrate schematic representations of exemplary configurations of film-type lithium ion batteries having one or more resistive layers serving as current limiters 6, for protecting the battery against overheating in the event of an internal short circuit, combined with current interrupters 8 that are thermally activatable by an increase in temperature, for irreversibly interrupting the self-discharge process in the event that the battery should overheat or achieve an or unsafe temperature.

[054] FIGs. 2A and 2B illustrate schematic representations of exemplary configurations of film-type lithium ion batteries having one or more layers serving as combined current limiters 6 and current interrupters 8, for protecting the battery against overheating in the event of an internal short circuit, combined with current interrupters 8 that

are voltaically activable by an increase in voltage, for irreversibly interrupting the self-discharge process in the event that the battery should become overcharged.

[055] FIGs. 3A and 3B illustrate schematic representations of exemplary configurations of film-type lithium ion batteries having one or more resistive layers serving as current limiters 6 for protecting the battery against overheating in the event of an internal short circuit, combined with current interrupters 8 that are thermally activable by an increase in temperature, for irreversibly interrupting the self-discharge process in the event that the battery should overheat or achieve an unsafe temperature, and further combined with current interrupters 8 that can be activated by an increase in voltage, for irreversibly interrupting the self-discharge process in the event that the battery should become overcharged.

[056] FIGs. 4A-4D illustrates cross sectional views of prior art film-type lithium ion batteries (FIGs. 4A and B) and of film-type lithium ion batteries of the present disclosure (FIGs. 4C and D).

[057] FIGs. 5A-5D illustrate cross sectional views of prior art film-type lithium ion batteries (FIGs. 5A and B) and of film-type lithium ion batteries of the present disclosure (FIGs. 5C and D).

[058] FIGs. 6A-6D illustrate cross sectional views of prior art film-type lithium ion batteries (FIGs. 6A and B) and of film-type lithium ion batteries of the present disclosure (FIGs. 6C and D).

[059] FIGs. 7A-7D illustrates cross sectional views of prior art film-type lithium ion batteries (FIGs. 7A and B) and of film-type lithium ion batteries of the present disclosure (FIGs. 7C and D).

[060] FIGs. 8A-8D illustrate cross sectional views of prior art film-type lithium ion batteries (FIGs. 8A and B) and of film-type lithium ion batteries of the present disclosure (FIGs. 8C and D).

[061] FIGs. 9A-9D illustrate cross sectional views of prior art film-type lithium ion batteries (FIGs. 9A and B) and of film-type lithium ion batteries of the present disclosure (FIGs. 9C and D).

[062] FIGs. 10A-10D illustrate cross sectional views of prior art film-type lithium ion batteries (FIGs. 10A and B) and of film-type lithium ion batteries of the present disclosure (FIGs. 10C and D).

[063] FIGs. 11A-11D illustrate cross sectional views of prior art film-type lithium ion batteries (FIGs. 11A and B) and of film-type lithium ion batteries of the present disclosure (FIGs. 11C and D).

[064] FIGs. 12A-12C illustrates exemplary structures for the combined current limiter 6 and current interrupter 8.

[065] FIGs. 13A and 13B illustrate exemplified Cell compositions.

[066] FIG. 14 illustrates the various positive electrode 14 formulations used in chemical decomposition voltage measurements.

[067] FIG. 15 illustrates the resistance of baseline Cell #2 at 3.6V vs graphite in relation to the temperature increase. The resistance decrease about 10 times with the increase in the temperature.

[068] FIG. 16 illustrates the resistance of Cell #3 (positive electrode 14 with the CaCO_3 ceramic layer) at 0, 3.646, and 4.11 respectively, voltage vs graphite in relation to the temperature increase. The resistance increases slightly for zero voltage, and dramatically for 3.646 and 4.11 V.

[069] FIG. 17 illustrates the resistance of Cell #4 (positive electrode 14 with the Al_2O_3 and CaCO_3 ceramic layer) at 0V and 3.655V, respectively, voltage vs graphite in relation to the temperature increase. The resistance increases slightly for zero voltage, and dramatically for 3.655 V.

[070] FIG. 18 illustrates the discharge capacity of baseline Cell #1 (no resistive layer) vs the cell voltage at 1A, 3A, 6A and 10A.

[071] FIG. 19 illustrates the discharge capacity of Cell #3 (85.2% CaCO_3 based resistive layer 6) vs the cell voltage at 1A, 3A, 6A and 10A. The cell discharge capability decreases significantly with the increase in the cell discharge current with this particular resistive layer 6.

[072] FIG. 20 summarizes the cell impedance and discharge capacities at 1A, 3A, 6A and 10A and their corresponding ratios of the capacity at 3A, 6A or 10A over that at 1A for Cell #1 (baseline), #3, #4, #5, and #6. The cell impedance at 1 KHz goes up with the resistive and gas-generator layer. The resistive layer 6 has caused the increase in the cell impedance since all cells with the resistive layer 6 gets higher impedance while the cell discharge capacity depends on the individual case.

[073] FIG. 21 illustrates the Impact Test.

[074] FIG. 22 illustrates the cell temperature profiles during the impact test for Cell #1 (baseline), #3, #5, and #6. The voltage of all tested cells dropped to zero as soon as

the steel rod impact the cell. All cells with the resistive and gas-generator layer passed the test while the cell without any resistive layer 6 failed in the test (caught the fire). The maximum cell temperature during the impact test is summarized in FIG. 23.

[075] FIG. 23 summarizes the cell maximum temperature in the impact test for Cell #1 (baseline), #3, #4, #5, and #6.

[076] FIG. 24 illustrates the cell voltage and temperature vs the impact testing time for Cell #6. The impact starting time is set to 2 minutes. The cell voltage drop to zero as soon as the cell is impacted. The cell temperature is shown to increase rapidly.

[077] FIG. 25 illustrates the cell voltage and temperature vs the overcharging time for Cell #1 (no any protection layer). The cell voltage increased gradually up to 40 minutes and then decreased slightly and jumped to the maximum charge voltage rapidly at about 56 minutes while at the same time the cell temperature increased dramatically to above 600°C. The cell voltage and temperature then dropped to a very low value due to the connection being lost when the cell caught fire. The overcharge current was 2A until the cell caught fire and then dropped to about 0.2A for one or two minutes and then back to 2A because the cell was shorted. The cell burned.

[078] FIG. 26 illustrates the cell voltage and temperature vs the overcharging time for the cell with Cell #3 (CaCO_3 layer). The cell voltage increased gradually up to 40 minutes and then rapidly increased to a maximum charge voltage of 12V at about 55 minutes. The cell temperature rapidly increased to above 80°C starting at about 40 minutes and then decreased rapidly. The over charge current decreased significantly at 55°C and kept to 0.2A for the rest of the testing time. The cell swelled significantly after the test.

[079] FIG. 27 illustrates the cell voltage and temperature vs the overcharging time for Cell #5 ($\text{Na}_2\text{O}_7\text{Si}_3 + \text{Al}_2\text{O}_3$ layer). The cell voltage increased gradually up to 40 minutes and then rapidly increased to a maximum charge voltage 12V at about 75 minutes. The cell overcharge voltage profiles is very different from CaCO_3 based resistive layer 6, which indicates the difference in the decomposition of $\text{Na}_2\text{O}_7\text{Si}_3$ compared with that of CaCO_3 . The cell temperature increased significantly at about 40 minutes to above 75°C and then decreased gradually. The over charge current decreased significantly at 75 minutes and kept to 1A for the rest of the testing time. The cell swelled significantly after the test.

[080] FIG. 28 summarizes the cell maximum temperature in the over charge test (2A/12V) for Cell #1 (baseline), #3, #4, #5, and #6.

[081] FIG. 29 illustrates the cycle life of Cell #3 (CaCO_3 resistive layer 6). The cell lost about 1.8% after 100 cycles which is lower than that of the cells without any resistive layer (~2.5% by average, not shown).

[082] FIG. 30 illustrates the cycle life of Cell #4 (CaCO_3 and Al_2O_3 resistive layer 6). The cell lost about 1.3% after 100 cycles which is lower than that of the cells without any resistive layer (~2.5% by average, not shown).

[083] FIG. 31 illustrates the current profiles vs the voltage at room temperature for compounds (gas generators) containing different anions for potential use in rechargeable batteries with different operation voltage. The peak current and voltages are listed in FIG. 32. The peak current for $\text{Cu}(\text{NO}_3)_2$ was the highest while the peak current for CaCO_3 was the lowest. The peak voltage for $\text{Cu}(\text{NO}_3)_2$ was the lowest while the peak voltage of CaCO_3 was the highest. Therefore, $\text{Cu}(\text{NO}_3)_2$ may be useful in lithium ion batteries with a relatively low operation voltage such as lithium ion cell using lithium iron phosphate positive electrode (3.7 V as the typical maximum charging voltage). CaCO_3 may be useful in lithium ion batteries with a high operation voltage like lithium ion cell using the high voltage positive such as lithium cobalt oxide (4.2V as the typical maximum charging voltage) or lithium nickel cobalt manganese oxides (4.3 or 4.4V as the typical high charging voltage).

[084] FIG. 32 summarizes the peak current and voltage for compounds containing different anions.

[085] FIG. 33 illustrates the current profiles vs the voltage for the polymers (organic gas generators) with or without different anions for potential use in rechargeable batteries with different operation voltage. PVDF is included as the reference. The peak current and voltages are listed in FIG. 34. The peak current for Carbopol, AI-50 and PVDF were very similar while CMC was the lowest. The peak voltage of Carbopol was the lowest while the CMC peak voltage was the highest. Therefore, Carbopol containing CO_3^{2-} anion maybe useful in lithium ion batteries with a relatively low operation voltage such as lithium ion cell using lithium iron phosphate positive electrode (3.7 V as the typical maximum charging voltage). CMC maybe useful in lithium ion batteries with a high operation voltage like lithium ion cell using the high voltage positive such as lithium cobalt oxide (4.2V as the typical maximum charging voltage) or lithium nickel cobalt manganese oxides (4.3 or 4.4V as the typical high charging voltage). Water is one of CMC decomposition compound and will react with the electrolyte and intercalated lithium in the negative graphite electrode to generate the gases such as hydrogen fluoride (HF) and oxygen (O_2) besides being vapor or gas above 100°C.

[086] FIG. 34 summarizes the peak current and voltage for polymers with or without different anions.

[087] FIG. 35 shows cell temperature and overcharge voltage profiles during 2A/12V overcharge test at room temperature.

[088] FIG. 36 illustrates the cell impedance and capacities at different currents for Cells 1, 3, 4, 5, and 6 described in Examples 9-12 below.

[089] FIG. 37 illustrates the resistance of Cell 2 (baseline, no resistive layer) at 3.6V vs graphite in relation to the temperature increase. The resistance decreased about 10 times with the increase in the temperature.

[090] FIG. 38 illustrates the resistance of Cell 3 at 4.09V vs graphite in relation to the temperature increase. The resistance decreased slightly and increased by about 3 times and then decreased by about 3 times with the increase in the temperature.

[091] FIG. 39 illustrates the discharge capacity of Cell 4 vs the cell voltage at 1A, 3A, 6A and 10A. The cell discharge capability decreases dramatically with the increase in the cell discharge current with this particular resistive layer.

[092] FIG. 40 illustrates the Cell temperature profiles during the impact test for Cells 1, 3, 4, 5, and 6, as described in Examples 9-12. All cells with the resistive layer passed the test while the cell without any resistive layer failed in the test (caught on fire). The maximum cell temperature during the impact test is summarized in FIG. 41.

[093] FIG. 41 illustrates the maximum temperature obtained by Cells 1, 3, 4, 5, and 6 during the impact test, as described in Examples 9-12.

[094] FIG. 42 illustrates the cycle life of Cell 3. The cell lost about 2% after 100 cycles which is similar to that of the cells without any resistive layer (~2.5% by average, not shown).

DETAILED DESCRIPTION

[095] Safe, long-term operation of high energy density rechargeable batteries, including lithium ion batteries, is a goal of battery manufacturers. One aspect of safe battery operation is controlling the heat generated by rechargeable batteries. As described above, many factors may cause the heat generated by a rechargeable battery to exceed its heat dissipation capacity, such as a battery defect, accident, or excessive internal current. When the heat generated by a battery exceeds its ability to dissipate heat, a rechargeable battery becomes susceptible to thermal runaway, overheating, and possibly even fire or violent explosion. Described below are apparatus and methods associated with a thermally activated

internal current interrupter that can interrupt the internal circuit of a rechargeable battery, preventing thermal runaway.

[096] Another aspect of safe battery operation is controlling the reactions at the electrodes of these rechargeable batteries during both battery charging and discharge. As described above, electrical current flows outside the battery, through an external circuit during use, while ions move from one electrode to another within the battery. In some cases, overcharge occurs and can lead to thermal runaway within the battery. Described below are apparatus and methods associated with an internal current limiter that limits the rate of internal discharge in a rechargeable battery when there is an internal short circuit.

[097] A further aspect of safe battery operation is controlling the discharge of these rechargeable batteries. As described above, a separator, or barrier layer, is used to separate the negative and positive electrodes in rechargeable batteries in which ions can move through the battery, but electrical current is forced to flow outside the battery, through an external circuit. Many factors may cause the separator to be breached, and may cause a short-circuit to occur within a rechargeable battery. A short-circuit leads to rapid discharge and possibly overheating and thermal runaway. Described below are apparatus and methods associated with an internal current limiter that limits the rate of internal discharge in a rechargeable battery when there is an internal short circuit.

[098] The terminology used herein is for the purpose of describing some particular exemplary embodiments only and is not intended to be limiting of the disclosure. As used herein, the singular forms are intended to include the plural forms as well, unless the context clearly indicates otherwise. It will be further understood that the terms "comprises" and/or "comprising," when used in this specification, specify the presence of stated features, integers, steps, operations, elements, and/or components, but do not preclude the presence or addition of one or more other features, integers, steps, operations, elements, components, and/or groups thereof.

[099] It will be understood that, although the terms "first," "second," etc. may be used herein to describe various members, elements, regions, layers and/or parts, these members, elements, regions, layers and/or parts should not be limited by these terms. These terms may be used merely to distinguish one member, element, region, layer and/or part from another member, element, region, layer and/or part. Thus, for example, a first member, element, region, layer and/or part discussed below could be termed a second member,

element, region, layer and/or part without departing from the teachings of the present disclosure.

[0100] FIGs. 1A-1G illustrate schematic representations of exemplary configurations of film-type lithium ion batteries having one or more resistive layers serving as current limiters (6 in FIGs. 4A-4D), for protecting the battery against overheating in the event of an internal short circuit, combined with current interrupters 8 that are thermally activatable by an increase in temperature, for irreversibly interrupting the self-discharge process in the event that the battery should overheat or achieve an or unsafe temperature. FIGs. 1A and 1C show configurations for batteries with a cathode current collector 101, a cathode energy layer 102, a separator 103, an anode energy layer 104, a resistive limiter and thermal interrupt layer 105, and an anode current collector 106. The configuration shown in FIG. 1B has a cathode current collector 101, a cathode energy layer 102, a separator 103, a first anode energy layer 107, a resistive limiter and thermal interrupt layer 105, a second anode energy layer 108, and an anode current collector 106. FIG. 1D shows a configuration a cathode current collector 101, a first cathode energy layer 109, a separator 103, a second cathode energy layer 110, a resistive limiter and thermal interrupt layer 105, an anode energy layer 104, and an anode current collector 106. FIGs. 1E-1G show configurations for batteries with a cathode current collector 101, a cathode energy layer 102, a separator 103, an anode energy layer 104, a first resistive limiter and thermal interrupt layer 111, a second resistive limiter and thermal interrupt layer 112, an anode energy layer 104, and an anode current collector 106.

[0101] FIGs. 2A and 2B illustrate schematic representations of exemplary configurations of film-type lithium ion batteries having one or more layers serving as combined current limiters 6 and current interrupters 8, for protecting the battery against overheating in the event of an internal short circuit, combined with current interrupters 8 that are voltaicly activable by an increase in voltage, for irreversibly interrupting the self-discharge process in the event that the battery should become overcharged. FIG. 2A shows a configuration for a battery with an anode current collector 201, an anode energy layer 202, a separator 203, a cathode energy layer 204, a resistive limiter and thermal interrupt layer 205, and a cathode current collector 206. The configuration shown in FIG. 2B has an anode current collector 201, an anode energy layer 202, a separator 203, a first cathode energy layer 207, a resistive limiter and thermal interrupt layer 205, a second cathode energy layer 208, and a cathode current collector 206.

[0102] FIGs. 3A and 3B illustrate schematic representations of exemplary configurations of film-type lithium ion batteries having one or more resistive layers serving as current limiters 6 for protecting the battery against overheating in the event of an internal short circuit, combined with current interrupters 8 that are thermally activable by an increase in temperature, for irreversibly interrupting the self-discharge process in the event that the battery should overheat or achieve an unsafe temperature, and further combined with current interrupters 8 that can be activated by an increase in voltage, for irreversibly interrupting the self-discharge process in the event that the battery should become overcharged. FIG. 3A shows a configuration for a battery with an anode current collector 301, an anode energy layer 302, a separator 303, a cathode energy layer 304, a resistive limiter, thermal interrupt, and voltaic interrupt layer 305, and a cathode current collector 306. The configuration shown in FIG. 3B has an anode current collector 301, an anode energy layer 302, a separator 303, a first cathode energy layer 307, a resistive limiter, thermal interrupt, and voltaic interrupt layer 305, a second cathode energy layer 308, and a cathode current collector 306.

[0103] FIGs. 4C and D illustrate the film-type lithium ion batteries of FIGs. 1A, 2A, or 3A. More particularly, FIGs. 4A-4D illustrate the current flow through film-type lithium ion batteries undergoing discharge for powering a load (L). FIGs. 4A and C illustrate the current flow of film-type lithium ion batteries having an intact fully operational separator 2 (unshorted). FIGs. 4B and D illustrate the current flow of film-type lithium ion batteries having a resistive layer serving as a current limiter 6, wherein the separator 2 has been short circuited by a conductive dendrite 10 penetrating therethrough. In FIGs. 4B and D, the cells are undergoing internal discharge due to a dendrite 10 penetrating the separator 2. Note that devices with unshorted separators 2 (FIGs. 4A and C) and the prior art device with the shorted separator 2 (FIG.4B), current flows from one current collector 4 to the other. However, in the exemplary device of the present disclosure having a shorted separator 2 and resistive layer 6 (FIG.4D), current flow is diverted from the current collector 4 and is much reduced. In FIG. 4D, the interrupter 8 has not been triggered.

[0104] FIGs. 5C and D illustrate the film-type lithium ion batteries of FIGs. 1A, 2A, or 3A. More particularly, FIGs. 5A-5D illustrate the current flow through film-type lithium ion batteries while it's being charged by a smart power supply (PS) that will stop the charging when it detects any abnormal charge voltage. FIGs. 5A and C illustrate the current flow of film-type lithium ion batteries having an intact fully operational separator 2 (unshorted). FIGs. 5B and D illustrate the current flow of film-type lithium ion batteries

having a separator 2 shorted by a conductive dendrite 10. Note that devices with unshorted separators 2 (FIGs. 5A and C) and the prior art device with the shorted separator 2 (FIG.5B), current flows from one current collector 4 to the other. However, in the exemplary device of the present disclosure having a shorted separator 2 and resistive layer 6 (FIG.5D), current flow is diverted from the current collector 4 and is much reduced. In FIG. 5D, the interrupter 8 has not been triggered.

[0105] FIGs. 6C and D illustrate the film-type lithium ion batteries of FIGs. 1A, 2A, or 3A, after the interrupter 8 has been triggered by excessive temperature or voltage. More particularly, FIGs. 6A-6D illustrate the current flow through film-type lithium ion batteries undergoing discharge for powering a load (L). FIGs. 6A and C illustrate the current flow of film-type lithium ion batteries having an intact fully operational separator 2 (unshorted). FIGs. 6B and D illustrate the current flow of film-type lithium ion batteries having a short circuit caused by a conductive dendrite 10 penetrating the separator 2. Note that devices with unshorted separators 2 (FIGs. 6A and C) and the prior art device with the shorted separator 2 (FIG. 6B), current flows from one current collector 4 to the other. However, in the exemplary device of the present disclosure having a shorted separator 2 and both a resistive layer (current limiter 6) and a current interrupter 8 (FIG. 6D), current flow is diverted from the current collector 4 and is much reduced. In FIG. 6D, the interrupter 8 has been triggered.

[0106] FIGs. 7C and D illustrate the film-type lithium ion batteries of FIGs. 1A, 2A, or 3A, after the interrupter 8 has been triggered by excessive temperature or voltage. More particularly, FIG. 7 illustrates the current flow through film-type lithium ion batteries while it's being charged by a smart power supply (PS) which will stop the charging when it detects any abnormal charging voltage. FIGs. 7A and C illustrate the current flow of film-type lithium ion batteries having an intact fully operational separator 2 (unshorted). FIGs. 7B and D illustrate the current flow of film-type lithium ion batteries having a having a short circuit caused by a separator 2 shorted by a dendrite 10. Note that devices with unshorted separators 2 (FIGs. 7A and C) and the prior art device with the shorted separator 2 (FIG. 7B), current flows from one current collector 4 to the other. However, in the exemplary device of the present disclosure having a shorted separator 2 and resistive layer 6 (current limiter 6) (FIG. 7D), current flow is diverted from the current collector 4 and is much reduced. In FIG. 7D, the interrupter 8 has been triggered.

[0107] FIGs. 8C and D illustrate the film-type lithium ion batteries of FIGs. 1A, 2A, or 3A. More particularly, FIGs. 8A-8D illustrate the current flow through film-type

lithium ion batteries undergoing discharge for powering a load (L). FIGs. 8A and C illustrate the current flow of film-type lithium ion batteries having an intact fully operational separator 2 (unshorted). FIGs. 8B and D illustrate the current flow of film-type lithium ion batteries having resistive layer serving as a current limiter 6, wherein the separator 2 has been short circuited by a disruption 16. In FIGs. 8B and D, the cells are undergoing internal discharge due to a breach 16 penetrating the separator 2. Note that devices with unshorted separators 2 (FIGs. 8A and C) and the prior art device with the shorted separator 2 (FIG. 8B), current flows from one current collector 4 to the other. However, in the exemplary device of the present disclosure having a shorted separator 2 and resistive layer 6 (FIG. 8D), current flow is diverted from the current collector 4 and is much reduced. In FIG. 8D, the interrupter 8 has not been triggered.

[0108] FIGs. 9C and D illustrate the film-type lithium ion batteries of FIGs. 1A, 2A, or 3A. More particularly, FIGs. 9A-9D illustrate the current flow through film-type lithium ion batteries while it's being charged by a smart power supply (PS) that will stop the charging when it detects any abnormal charge voltage. FIGs. 9A and C illustrate the current flow of film-type lithium ion batteries having an intact fully operational separator 2 (unshorted). FIGs. 9B and D illustrate the current flow of film-type lithium ion batteries having a having a separator 2 shorted by a by a disruption 16. Note that devices with unshorted separators 2 (FIGs. 9A and C) and the prior art device with the shorted separator 2 (FIG. 9B), current flows from one current collector 4 to the other. However, in the exemplary device of the present disclosure having a shorted separator 2 and resistive layer 6 (FIG. 9D), current flow is diverted from the current collector 4 and is much reduced. In FIG. 9D, the interrupter 8 has not been triggered.

[0109] FIGs. 10C and D illustrate the film-type lithium ion batteries of FIGs. 1A, 2A, or 3A, after the interrupter 8 has been triggered by excessive temperature or voltage. More particularly, FIGs. 10A-10D illustrate the current flow through film-type lithium ion batteries undergoing discharge for powering a load (L). FIGs. 10A and C illustrate the current flow of film-type lithium ion batteries having an intact fully operational separator 2 (unshorted). FIGs. 10B and D illustrate the current flow of film-type lithium ion batteries having a short circuit caused by a disruption 16. Note that devices with unshorted separators 2 (FIGs. 10A and C) and the prior art device with the shorted separator 2 (FIG. 10B), current flows from one current collector 4 to the other. However, in the exemplary device of the present disclosure having a shorted separator 2 and both a resistive layer (current limiter 6)

and a current interrupter 8 (FIG. 6D), current flow is diverted from the current collector 4 and is much reduced. In FIG. 10D, the interrupter 8 has been triggered.

[0110] FIGs. 11C and D illustrate the film-type lithium ion batteries of FIGs. 1A, 2A, or 3A, after the interrupter 8 has been triggered by excessive temperature or voltage. More particularly, FIGs. 11A-11D illustrate the current flow through film-type lithium ion batteries while it's being charged by a smart power supply (PS) that will stop the charging when it detects any abnormal charge voltage. FIGs. 11A and C illustrate the current flow of film-type lithium ion batteries having an intact fully operational separator 2 (unshorted). FIGs. 11B and D illustrate the current flow of film-type lithium ion batteries having a having a short circuit caused by a separator 2 shorted by a disruption 16. Note that devices with unshorted separators 2 (FIGs. 11A and C) and the prior art device with the shorted separator 2 (FIG. 11B), current flows from one current collector 4 to the other. However, in the exemplary device of the present disclosure having a shorted separator 2 and resistive layer 6 (current limiter 6) (FIG. 11D), current flow is diverted from the current collector 4 and is much reduced. In FIG. 11D, the interrupter 8 has been triggered.

[0111] FIG. 12A illustrates resistive layer 6 having a high proportion of ceramic particles coated with binder. Interstitial voids between the coated ceramic particles render the resistive layer 6 porous. FIG. 12B illustrates resistive layer 6 having a high proportion of ceramic particles bound together by particles of binder. Interstitial voids between the coated ceramic particles render the resistive layer 6 porous. FIG. 12C illustrates resistive layer 6 having an intermediate proportion of ceramic particles (less than 80%) held together with binder. The resistive layer 6 lacks interstitial voids between the coated ceramic particles and is non-porous.

Current Limiter

[0112] A first aspect of the disclosure is directed to an improved HEDR battery of a type including an anode energy layer 12, a cathode energy layer 14, a separator 2 between the anode energy layer 12 and the cathode energy layer 14 for preventing internal discharge thereof, and at least one current collector 4 for transferring electrons to and from either the anode or cathode energy layer. The anode and cathode energy layers each have an internal resistivity. The HEDR battery has a preferred temperature range for discharging electric current and an upper temperature safety limit. The improvement is employable, in the event of separator failure, for limiting the rate of internal discharge through the failed separator and the generation of joule heat resulting therefrom. More particularly, the improvement

comprises a resistive layer 6 interposed between the separator and one of the current collectors 4 for limiting the rate of internal discharge through the failed separator in the event of separator failure. The resistive layer 6 has a fixed resistivity at temperatures between the preferred temperature range and the upper temperature safety limit. The fixed resistivity of the resistive layer 6 is greater than the internal resistivity of either energy layer. The resistive layer 6 helps the battery avoid temperatures in excess of the upper temperature safety limit in the event of separator failure.

[0113] Some embodiments of the present disclosure include an improved high energy density rechargeable battery are of a type including:

1. two electrodes (12 and 14) of opposite polarity, each electrode characterized by its resistivity, by its safe operating temperature range, and its safe charging voltage; the two electrodes being subject to a risk of overcharge above the safe charging voltage and the formation of the short circuit therefrom; the two electrodes being subject to a risk of thermal runaway above the safe operating temperature range.
2. a separator 2 for separating the two electrodes and preventing internal discharge therebetween; the separator being subject to a risk of forming a short circuit, the short circuit potentially allowing a rapid internal discharge between the two electrodes, the rapid internal discharge between the two electrodes potentially allowing a rapid production of joule heat therefrom, the rapid production of joule heat potentially allowing a thermal runaway.
3. at least one electrode employing a current collector 4 for transferring electrons.
4. a current limiter 6 forming an electrical coupling between one of the electrodes and its corresponding current collector, the current limiter having a resistivity for resistively impeding current therethrough and, in the event the separator forms the short circuit, for diverting current from the electrode current collector to which it is coupled, and for reducing the rate of the internal discharge between the two electrodes.
5. a current interrupter 8 having an engaged configuration, an disengaged configuration, and a gas generating component for transitioning the current interrupter from the engaged to the unengaged configuration, the gas generating component having a trigger for generating a gas, the trigger being selected from the group consisting of temperature triggers and voltage triggers, the temperature triggers being activatable above the safe operating temperature range; the voltage triggers being activatable above the safe charging voltage; in the engaged configuration, the

current interrupter electrically coupling one of the electrodes and its corresponding current collector with a laminated connection, in the disengaged configuration, the laminated connection becoming delaminated and the current interrupter forming a nonconductive gap for interrupting the electrical coupling between the electrode and its corresponding current collector, the current interrupter transitioning from the engaged to the disengaged configuration by triggering the gas generating component responsive to the trigger, the generated gas delaminating the laminated connection for interrupting the electrical coupling between the electrode and its corresponding current collector, whereby the current limiter and the current interrupter, in combination, diminishing the risk of thermal runaway resulting from separator short circuit, electrode overcharge, and electrode overheating.

[0114] In some embodiments, the current interrupter is triggered by temperature.

[0115] In some embodiments, the current interrupter includes a layer containing a single gas generating component triggered by temperature.

[0116] In some embodiments, the current interrupter is triggered by voltage.

[0117] In some embodiments, the current interrupter includes a layer containing a single gas generating component triggered by voltage.

[0118] In some embodiments, the current interrupter is triggered by temperature and voltage.

[0119] In some embodiments, the current interrupter includes a layer containing a single gas generating component triggered by temperature and voltage.

[0120] In some embodiments, the current interrupter includes a layer containing two gas generating components, one triggered by temperature and the other triggered by voltage.

[0121] In some embodiments, the current interrupter may include a layer containing one or more inorganic gas generating compounds that generate gas at a specific temperature or voltage.

[0122] In some embodiments, the inorganic gas generating compounds are selected from the group consisting of CaCO_3 , $\text{La}_2(\text{CO}_3)_3$, Na_2SO_3 , $\text{ZnCO}_3\text{Zn}(\text{OH})_2$, $\text{CuCO}_3\text{Cu}(\text{OH})_2$, and $\text{Cu}(\text{NO}_3)_2$ as disclosed in FIG. 32.

[0123] In some embodiments, the current interrupter may include a layer containing one or more organic gas generating compounds that generate gas at a specific temperature or voltage.

[0124] In some embodiments, the organic gas generating compounds are selected from the group consisting of Carbopol, Torlon[®] AI-50, CMC, and PVDF as disclosed in FIG. 34.

[0125] In some embodiments, the current interrupter may include a layer containing a combination of inorganic and organic gas generating compounds that generate gas at a specific temperature or voltage.

[0126] In some embodiments of the improved high energy density rechargeable battery, the current limiter and the current interrupter are simultaneously incorporated into a protective layer interposed by lamination between the same electrode and current collector, as disclosed in FIGs. 1A, 1C, and 2A.

[0127] In some embodiments of the improved high energy density rechargeable battery, the current limiter and the current interrupter triggered by both temperature and voltage are simultaneously incorporated into a protective layer interposed by lamination between the same electrode and current collector, as disclosed in FIG. 3A.

[0128] In some embodiments, the improved high energy density rechargeable battery is of a type having two current collectors, including a first current collector and a second current collector, the two electrodes including a first electrode and a second electrode, the improvement further characterized wherein:

the current limiter and the current interrupter are simultaneously incorporated into a first protective layer interposed by lamination between the first electrode and the first current collector; and

the current limiter and the current interrupter are simultaneously incorporated into a second protective layer interposed by lamination between the second electrode and the second current collector,

as disclosed in FIG. 1E.

[0129] In some embodiments, the improved high energy density rechargeable battery is of a type having two current collectors, including a first current collector and a second current collector, the two electrodes including a first electrode and a second electrode, the improvement further characterized wherein:

the current limiter and the current interrupter are simultaneously incorporated into a first protective layer interposed by lamination between the first electrode and the first current collector; and

the current limiter and the current interrupter are simultaneously incorporated into a second protective layer interposed by lamination between the second electrode and the separator,

as disclosed in FIG. 1F.

[0130] In some embodiments, the improved high energy density rechargeable battery is of a type having two current collectors, including a first current collector and a second current collector, the two electrodes including a first electrode and a second electrode, the improvement further characterized wherein:

the current limiter and the current interrupter are simultaneously incorporated into a first protective layer interposed by lamination between the first electrode and the separator; and

the current limiter and the current interrupter are simultaneously incorporated into a second protective layer interposed by lamination between the second electrode and the second current collector,

as disclosed in FIG. 1G.

[0131] In some embodiments, the improved high energy density rechargeable battery is of a type having two current collectors, including a first current collector and a second current collector, the two electrodes including a first electrode and a second electrode, and the first electrode including a first portion and a second portion, the second portion of the first electrode interposed between the first portion of the first electrode and the first current collector, the improvement further characterized wherein:

1. the current limiter being layered between the first portion of the first electrode and the second portion of the first electrode; and
2. the current interrupter being layered between the second portion of the first electrode and the first current collector.

[0132] In some embodiments, the improved high energy density rechargeable battery is of a type having two current collectors, including a first current collector and a second current collector, the two electrodes including a first electrode and a second electrode, and the first electrode including a first portion and a second portion, the second portion of the first electrode interposed between the first portion of the first electrode and the first current collector, the improvement further characterized, wherein the current limiter and the current interrupter are simultaneously incorporated into a protective layer interposed by lamination between the first portion and the second portion of the first electrode, as disclosed in FIGs. 1B and 2B.

[0133] In some embodiments, the improved high energy density rechargeable battery is of a type having two current collectors, including a first current collector and a second current collector, the two electrodes including a first electrode and a second electrode, and the first electrode including a first portion and a second portion, the second portion of the first electrode interposed between the first portion of the first electrode and the first current collector, the improvement further characterized, wherein the current limiter and the current interrupter triggered by both temperature and voltage are simultaneously incorporated into a protective layer interposed by lamination between the first portion and the second portion of the first electrode, as disclosed in FIG. 3B.

[0134] In some embodiments, the improved high energy density rechargeable battery is of a type having two current collectors, including a first current collector and a second current collector, the two electrodes including a first electrode and a second electrode, and the second electrode including a first portion and a second portion, the first portion of the second electrode interposed between the second portion of the second electrode and the second current collector, the improvement further characterized wherein:

1. the current limiter being layered between the first portion of the second electrode and the second portion of the second electrode; and
2. the current interrupter being layered between the second portion of the second electrode and the second current collector.

[0135] In some embodiments, the improved high energy density rechargeable battery is of a type having two current collectors, including a first current collector and a second current collector, the two electrodes including a first electrode and a second electrode, and the second electrode including a first portion and a second portion, the first portion of the second electrode interposed between the second portion of the second electrode and the second current collector, the improvement further characterized wherein:

1. the current interrupter being layered between the first portion of the second electrode and the second portion of the second electrode; and
2. the current limiter being layered between the second portion of the second electrode and the second current collector.

[0136] In some embodiments, the improved high energy density rechargeable battery is of a type having two current collectors, including a first current collector and a second current collector, the two electrodes including a first electrode and a second electrode, and the first electrode including a first portion and a second portion, the first portion of the second electrode interposed between the second portion of the second electrode

and the second current collector, the improvement further characterized, wherein the current limiter and the current interrupter are simultaneously incorporated into a protective layer interposed by lamination between the first portion and the second portion of the second electrode, as disclosed in FIG. 1D.

[0137] In some embodiments, the improved high energy density rechargeable battery is of a type having two current collectors, including a first current collector and a second current collector, the two electrodes including a first electrode and a second electrode, and the first electrode including a first portion and a second portion, the second portion of the first electrode interposed between the first portion of the first electrode and the first current collector, the improvement further characterized wherein:

1. the current limiter being layered between the second portion of the first electrode and the first current collector; and
2. the current interrupter being layered between the first portion of the first electrode and the second portion of the first electrode.

[0138] In some embodiments, the improved high energy density rechargeable battery is of a type having two current collectors, including a first current collector and a second current collector and the two electrodes including a first electrode and a second electrode, the improvement further characterized, wherein:

1. the current limiter being layered between the first electrode and the first current collector; and
2. the current interrupter being layered between the second electrode and the second current collector.

[0139] In some embodiments, the improved high energy density rechargeable battery is of a type, wherein each electrode has a temperature range for safe operation and an internal resistivity therein, the improvement further characterized wherein the current limiter having a resistivity greater than the internal resistivity of the electrode with which the current limiter is layered within the temperature range for safe operation.

[0140] In some embodiments of the improved high energy density rechargeable battery, the improvement further characterized, wherein the current limiter lacking a resistivity transition switch at temperatures within the temperature range for safe operation.

[0141] In some embodiments, the improved high energy density rechargeable battery is of a type, wherein each electrode has a temperature range for standard operation, the improvement further characterized, wherein the current limiter having a resistivity transition with a resistivity less than the internal resistivity of the electrode within the

temperature range for standard operation and a resistivity greater than the internal resistivity of the electrode above the temperature range for standard operation.

[0142] In some embodiments, the improved high energy density rechargeable battery is of a type, wherein each electrode has a temperature range for standard operation, the improvement further characterized, wherein the current interrupter is activated by temperature above the temperature range for standard operation.

[0143] In some embodiments, the improved high energy density rechargeable battery is of a type, wherein each electrode has a temperature range for standard operation and a temperature range for safe operation, the improvement further characterized, wherein the current interrupter is activated by temperature above the temperature range for standard operation and within the temperature range for safe operation.

[0144] In some embodiments, the improved high energy density rechargeable battery is of a type, wherein each electrode has an internal resistivity within the temperature range for safe operation, the improvement further characterized, wherein the current limiter having a resistivity greater than the internal resistivity of the electrode with which the current limiter is layered within the temperature range for safe operation.

[0145] In some embodiments of the improved high energy density rechargeable battery, the improvement further characterized, wherein the current limiter and the current interrupter are simultaneously incorporated into a protective layer interposed by lamination between the same electrode and current collector.

[0146] In some embodiments, the improved high energy density rechargeable battery is of a type, wherein each electrode has a voltage range for standard operation, the improvement further characterized, wherein the current interrupter is activated by voltage above the voltage range for standard operation.

[0147] In some embodiments, the improved high energy density rechargeable battery is of a type, wherein each electrode has a voltage range for standard operation and a voltage range for safe operation, the improvement further characterized, wherein the current interrupter is activated by voltage above the temperature range for standard operation and within the voltage range for safe operation.

[0148] In some embodiments of the improved high energy density rechargeable battery, the improvement further characterized, wherein the current limiter and the current interrupter are simultaneously incorporated into a protective layer interposed by lamination between the same electrode and current collector.

[0149] Other embodiments of the present disclosure include an improved high energy density rechargeable battery of a type including two electrodes of opposite polarity, a separator separating the two electrodes, and at least one current collector electrically coupled to one of the electrodes, the separator preventing internal discharge between the two electrodes, failure of the separator potentially causing an internal discharge between the two electrodes (as illustrated in FIGs. 6A-B and FIGs. 7A-B), the internal discharge causing a generation of joule heat of potential danger, the improvement comprising:

1. a thermally activatable current interrupter and a voltage activatable current interrupter, wherein the thermally activatable current interrupter layered by lamination between one of the current collectors and one of the electrodes, the thermally activatable current interrupter, when unactivated, electrically coupling the current collector to the electrode with which it is layered, the current interrupter, when activated, delaminating from the current collector for forming a nonconductive gap for electrically decoupling the current collector from the electrode with which it had been layered (as illustrated in FIGs. 6C-D and FIGs. 7C-D), the electrical decoupling slowing the rate of internal discharge between the two electrodes in the event of separator failure;
2. the voltage activatable current interrupter layered by lamination between one of the current collectors and one of the electrodes, the voltage activatable current interrupter, when unactivated, electrically coupling the current collector to the electrode with which it is layered, the current interrupter, when activated, delaminating from the current collector for forming a nonconductive gap for electrically decoupling the current collector from the electrode with which it had been layered, the electrical decoupling slowing the rate of internal discharge between the two electrodes in the event of separator failure (as illustrated in FIGs. 6C-D and FIGs. 7C-D);

whereby, activation of either the thermally activated current interrupter or voltage activated current interrupter in the event of separator failure, slows the generation joule heat for diminishing the potential danger.

[0150] Some embodiments of the present disclosure include a process for avoiding thermal runaway within a high energy density rechargeable battery undergoing internal discharge due to separator failure, the process comprising delaminating an electrode within the battery from its current collector by generating a gas from a heat sensitive gas generating material within an interrupt layer interposed between the electrode and current

collector, the delaminating electrically decoupling the electrode from its current collector for slowing the rate of internal discharge.

[0151] Some embodiments of the present disclosure include a process for avoiding thermal runaway within a high energy density rechargeable battery at risk of suffering from separator failure due to voltage overcharge (as illustrated in FIGs. 7A-B), the process comprising delaminating an electrode within the battery from its current collector by generating a gas from a voltage sensitive gas generating material within an interrupt layer interposed between the electrode and current collector, the delaminating electrically decoupling the electrode from its current collector for interrupting the voltage overcharge (as illustrated in FIGs. 7C-D).

[0152] The following abbreviations have the indicated meanings:

Carbopol[®]-934 = cross-linked polyacrylate polymer supplied by Lubrizol Advanced Materials, Inc.

CMC = carboxymethyl cellulose

CMC-DN-800H = CMC whose sodium salt of the carboxymethyl group had been replaced by ammonium (supplied by Daicel FineChem Ltd).

MCMB = mesocarbon microbeads

NMC = Nickel, Manganese and Cobalt

NMP = N-methylpyrrolidone

PTC = positive temperature coefficient

PVDF = polyvinylidene fluoride

SBR = styrene butadiene rubber

Super P[®] = conductive carbon blacks supplied by Timcal

Torlon[®] AI-50 = water soluble analog of Torlon[®] 4000TF

Torlon[®] 4000TF = neat resin polyamide-imide (PAI) fine powder

[0153] Preparation of the resistance layer and electrode active layer is described below, along with battery cell assembly.

[0154] The following is a generalized procedure for preparing a resistance layer (first layer):

- i. Dissolve the binder into an appropriate solvent.
- ii. Add the conductive additive and ceramic powder into the binder solution to form a slurry.

- iii. Coat the slurry made in Step ii. onto the surface of a metal foil, and then dry it to form a resistance layer on the surface of the foil.

[0155] The following is a generalized procedure for the electrode preparation (on the top of the first layer):

- i. Dissolve the binder into an appropriate solvent.
- ii. Add the conductive additive into the binder solution to form a slurry.
- iii. Put the cathode or anode material into the slurry made in the Step v. and mix it to form the slurry for the electrode coating.
- iv. Coat the electrode slurry made in the Step vi. onto the surface of the layer from Step iii.
- v. Compress the electrode into the design thickness.

[0156] The following is a generalized procedure for Cell assembly:

- i. Dry the positive electrode at 125°C for 10 hr and negative electrode at 140°C for 10 hr.
- ii. Punch the electrodes into the pieces with the electrode tab.
- iii. Laminate the positive and negative electrodes with the separator as the middle layer.
- iv. Put the flat jelly-roll made in the Step xi. into the Aluminium composite bag.

[0157] Below are the generalized steps for conducting an impact test, as shown in FIG. 21, for a battery cell as described herein.

- i. Charge the cell at 2A and 4.2V for 3 hr.
- ii. Put the cell onto a hard flat surface such as concrete.
- iii. Attach a thermal couple to the surface of the cell with high temperature tape and connect the positive and negative tabs to the voltage meter.
- iv. Place a steel rod (15.8 mm±0.1 mm in diameter X about 70 mm long) on its side across the center of the cell.
- v. Suspend a 9.1±0.46 Kg steel block (75 mm in diameter X 290 mm high) at a height of 610±25 mm above the cell.
- vi. Using a containment tube (8 cm inside diameter) to guide the steel block, release the steel block through the tube and allow it to free

fall onto the steel bar laying on the surface of the cell causing the separator to breach while recording the temperature.

- vii. Leave the steel rod and steel block on the surface of the cell until the cell temperature stabilizes near room temperature.
- viii. End test.

[0158] Below are the generalized steps for performing an overcharge test.

- i. Charge the cell at 2A and 4.2V for 3 hr.
- ii. Put the charged cell into a room temperature oven.
- iii. Connect the cell to a power supply (manufactured by Hewlett-Packard).
- iv. Set the voltage and current on the power supply to 12V and 2A.
- v. Turn on the power supply to start the overcharge test while recording the temperature and voltage.
- vi. Test ends when the cell temperature decreases and stabilizes near room temperature.

[0159] Below are the generalized steps for performing the Resistance Measurement Test.

- i. Place one squared copper foil (4.2 X 2.8 cm) with the tab on to a metal plate (~12 X ~8 cm). Then cut a piece of thermal tape and carefully cover the squared copper foil.
- ii. Cut a piece of the electrode that is slightly larger than the copper paper. Place the electrode on to the copper foil.
- iii. Place another copper foil (4.2X2.8 cm) with tab on the electrode surface, repeat steps i - ii with it. .
- iv. At this point, carefully put them together and cover them using high temperature tape and get rid of any air bubble
- v. Cut a “V” shaped piece of metal off both tabs.
- vi. Attach the completed strip to the metal clamp and tighten the screws. Make sure the screws are really tight.
- vii. Attach the tabs to the connectors of Battery HiTester (produced by Hioki USA Corp.) to measure the resistance to make sure that a good sample has been made for the measurement.

- viii. Put the metal clamp inside the oven, connect the “V” shaped tabs to the connectors and then tightened the screw. Tape the thermocouple onto the metal clamp.
- ix. Attach the Battery HiTester to the wires from oven. Do not mix up the positive and the negative wires.
- x. Close the oven and set the temperature to 200°C at 4°C per minute, and start the test. Record data every 15 seconds.
- xi. Stop recording the data when the metal clamp and oven reach just a little over 200°C.
- xii. Turn off the oven and the Battery HiTester.
- xiii. End Test.

[0160] Below are the generalized steps for performing the Cycle Life procedure.

- i. Rest for 5 minutes.
- ii. Discharge to 2.8V at 1A.
- iii. Rest for 20 minutes.
- iv. Charge to 4.2V at 0.7A for 270 minutes.
- v. Rest for 10 minutes.
- vi. Discharge to 2.8V at 0.7A.
- vii. Rest for 10 minutes.
- viii. Repeat Steps iii to vii 100 times.
- ix. End test.

[0161] Below are the generalized steps for testing a battery cell with a resistance layer for discharge at 1A, 3A, 6A, and 10A. In each test, the battery cell is tested in a chamber with controlled, constant temperature, for example 50°C.

- i. Rest for 5 minutes.
- ii. Discharge to 2.8V at 1A.
- iii. Rest for 20 minutes.
- iv. Charge to 4.2V at 0.7A for 270 minutes.
- v. Rest for 10 minutes.
- vi. Discharge to 2.8V at 1A.
- vii. Rest for 10 minutes.
- viii. Charge to 4.2V at 0.7A for 270 minutes.
- ix. Rest for 10 minutes.
- x. Discharge to 2.8V at 3A.

- xi. Charge to 4.2V at 0.7A for 270 minutes.
- xii. Rest for 10 minutes.
- xiii. Discharge to 2.8V at 6A.
- xiv. Charge to 4.2V at 0.7A for 270 minutes.
- xv. Rest for 10 minutes.
- xvi. Discharge to 2.8V at 10A.
- xvii. Rest for 10 minutes.
- xviii. End Test.

Definitions

[0162] Unless defined otherwise, all technical and scientific terms used herein have the same meaning as is commonly understood by one of ordinary skill in the art to which this disclosure belongs. In the event that there is a plurality of definitions for a term herein, those in this section prevail unless stated otherwise.

[0163] As used herein, “high energy density rechargeable (HEDR) battery” means a battery capable of storing relatively large amounts of electrical energy per unit weight on the order of about 50 W-hr/kg or greater and is designed for reuse, and is capable of being recharged after repeated uses. Non-limiting examples of HEDR batteries include metal-ion batteries and metallic batteries.

[0164] As used herein, “metal-ion batteries” means any rechargeable battery types in which metal ions move from the negative electrode to the positive electrode during discharge and back when charging. Non-limiting examples of metal-ion batteries include lithium-ion, aluminum-ion, potassium-ion, sodium-ion, magnesium-ion, and others.

[0165] As used herein, “metallic batteries” means any rechargeable battery types in which the anode is a metal or metal alloy. The anode can be solid or liquid. Metal ions move from the negative electrode to the positive electrode during discharge and back when charging. Non-limiting examples of metallic batteries include M-S, M-NiCl₂, M-V₂O₅, M-Ag₂VP₂O₈, M-TiS₂, M-TiO₂, M-MnO₂, M-Mo₃S₄, M-MoS₆Se₂, M-MoS₂, M-MgCoSiO₄, M-Mg_{1.03}Mn_{0.97}SiO₄, and others, where M = Li, Na, K, Mg, Al, or Zn.

[0166] As used herein, “lithium-ion battery” means any rechargeable battery types in which lithium ions move from the negative electrode to the positive electrode during discharge and back when charging. Non-limiting examples of lithium-ion batteries include lithium cobalt oxide (LiCoO₂), lithium iron phosphate (LiFePO₄), lithium cobalt phosphate (LiCoPO₄), lithium excess layered oxides such as (LiMnO₃)_x(LiMO₂) (M=Ni, Co, Mn),

olivines, LiMSiO_4 (M=iron, Cobalt, Nickel and Vanadium); lithium manganese oxide (LiMn_2O_4), lithium nickel oxide (LiNiO_2), lithium nickel manganese cobalt oxide (LiNiMnCoO_2), lithium nickel cobalt aluminum oxide (LiNiCoAlO_2), lithium titanate ($\text{Li}_4\text{Ti}_5\text{O}_{12}$), lithium titanium dioxide, lithium/graphene, lithium/graphene oxide coated sulfur, lithium-sulfur, lithium-purpurin, and others. Lithium-ion batteries can also come with a variety of anodes including silicon-carbon nanocomposite anodes and others. Lithium-ion batteries can be in various shapes including small cylindrical (solid body without terminals), large cylindrical (solid body with large threaded terminals), prismatic (semi-hard plastic case with large threaded terminals), and pouch (soft, flat body). Lithium polymer batteries can be in a soft package or pouch. The electrolytes in these batteries can be a liquid electrolyte (such as carbonate based or ionic), a solid electrolyte, a polymer based electrolyte or a mixture of these electrolytes.

[0167] As used herein, “aluminum-ion battery” means any rechargeable battery types in which aluminum ions move from the negative electrode to the positive electrode during discharge and back when charging. Non-limiting examples of aluminum-ion batteries include $\text{Al}_n\text{M}_2(\text{XO}_4)_3$, wherein X = Si, P, S, Mo, As, and others; and M = Fe, Ca, Mg, V, Cr and others; aluminum transition-metal oxides (Al_xMO_2 wherein M = Fe, Mn, Ni, Mo, Co, Cr, Ti, V and others) such as $\text{Al}_x(\text{V}_4\text{O}_8)$, Al_xNiS_2 , Al_xFeS_2 , Al_xVS_2 and Al_xWS_2 and others.

[0168] As used herein, “potassium-ion battery” means any rechargeable battery types in which potassium ions move from the negative electrode to the positive electrode during discharge and back when charging. Non-limiting examples of potassium-ion batteries include $\text{K}_n\text{M}_2(\text{XO}_4)_3$, wherein X = Si, P, S, Mo, As, and others; and M = Fe, Ca, Mg, V, Cr and others; potassium transition-metal oxides (KMO_2 wherein M = Fe, Mn, Ni, Mo, Co, Cr, Ti, V and others), and others.

[0169] As used herein, “sodium-ion battery” means any rechargeable battery types in which sodium ions move from the negative electrode to the positive electrode during discharge and back when charging. Non-limiting examples of sodium-ion batteries include $\text{Na}_n\text{M}_2(\text{XO}_4)_3$, wherein X = Si, P, S, Mo, As, and others; and M = Fe, Ca, Mg, V, Cr and others; $\text{NaV}_{1-x}\text{Cr}_x\text{PO}_4\text{F}$, NaVPO_4F , $\text{Na}_4\text{Fe}_3(\text{PO}_4)_2(\text{P}_2\text{O}_7)$, $\text{Na}_2\text{FePO}_4\text{F}$, $\text{Na}_2\text{FeP}_2\text{O}_7$, $\text{Na}_{2/3}[\text{Fe}_{1/2}\text{Mn}_{1/2}]\text{O}_2$, $\text{Na}(\text{Ni}_{1/3}\text{Fe}_{1/3}\text{Mn}_{1/3})\text{O}_2$, NaTiS_2 , NaFeF_3 ; Sodium Transition-Metal Oxides (NaMO_2 wherein M = Fe, Mn, Ni, Mo, Co, Cr, Ti, V and others) such as $\text{Na}_{2/3}[\text{Fe}_{1/2}\text{Mn}_{1/2}]\text{O}_2$, $\text{Na}(\text{Ni}_{1/3}\text{Fe}_{1/3}\text{Mn}_{1/3})\text{O}_2$, $\text{Na}_x\text{Mo}_2\text{O}_4$, NaFeO_2 , $\text{Na}_{0.7}\text{CoO}_2$, NaCrO_2 , NaMnO_2 , $\text{Na}_{0.44}\text{MnO}_2$, $\text{Na}_{0.7}\text{MnO}_2$, $\text{Na}_{0.7}\text{MnO}_{2.25}$, $\text{Na}_{2/3}\text{Mn}_{2/3}\text{Ni}_{1/3}\text{O}_2$, $\text{Na}_{0.61}\text{Ti}_{0.48}\text{Mn}_{0.52}\text{O}_2$; Vanadium Oxides such as $\text{Na}_{1+x}\text{V}_3\text{O}_8$, $\text{Na}_x\text{V}_2\text{O}_5$, and Na_xVO_2 ($x = 0.7, 1$); and others.

[0170] As used herein, “magnesium-ion battery” means any rechargeable battery types in which magnesium ions move from the negative electrode to the positive electrode during discharge and back when charging. Non-limiting examples of magnesium-ion batteries include $Mg_nM_2(XO_4)_3$, wherein X = Si, P, S, Mo, As, and others; and M = Fe, Ca, Mg, V, Cr and others; magnesium Transition-Metal Oxides ($MgMO_2$ wherein M = Fe, Mn, Ni, Mo, Co, Cr, Ti, V and others), and others.

[0171] As used herein, “silicon-ion battery” means any rechargeable battery types in which silicon ions move from the negative electrode to the positive electrode during discharge and back when charging. Non-limiting examples of silicon-ion batteries include $Si_nM_2(XO_4)_3$, wherein X = Si, P, S, Mo, As, and others; and M = Fe, Ca, Mg, V, Cr and others; Silicon Transition-Metal Oxides ($SiMO_2$ wherein M = Fe, Mn, Ni, Mo, Co, Cr, Ti, V and others), and others.

[0172] As used herein, “binder” means any material that provides mechanical adhesion and ductility with inexhaustible tolerance of large volume change. Non-limiting examples of binders include styrene butadiene rubber (SBR)-based binders, polyvinylidene fluoride (PVDF)-based binders, carboxymethyl cellulose (CMC)-based binders, poly(acrylic acid) (PAA)-based binders, polyvinyl acids (PVA)-based binders, poly(vinylpyrrolidone) (PVP)-based binders, and others.

[0173] As used herein, “conductive additive” means any substance that increases the conductivity of the material. Non-limiting examples of conductive additives include carbon black additives, graphite nonaqueous ultrafine carbon (UFC) suspensions, carbon nanotube composite (CNT) additives (single and multi-wall), carbon nano-onion (CNO) additives, graphene-based additives, reduced graphene oxide (rGO), conductive acetylene black (AB), conductive poly(3-methylthiophene) (PMT), filamentary nickel powder additives, aluminum powder, electrochemically active oxides such as lithium nickel manganese cobalt oxide and others.

[0174] As used herein, “metal foil” means any metal foil that under high voltage is stable. Non-limiting examples of metal foils include aluminum foil, copper foil, titanium foil, steel foil, nano-carbon paper, graphene paper, carbon fiber sheet, and others.

[0175] As used herein, “ceramic powder” means any electrical insulator or electrical conductor that hasn’t been fired. Non-limiting examples of ceramic powder materials include barium titanate ($BaTiO_3$), zirconium barium titanate, strontium titanate ($SrTiO_3$), calcium titanate ($CaTiO_3$), magnesium titanate ($MgTiO_3$), calcium magnesium titanate, zinc titanate ($ZnTiO_3$), lanthanum titanate ($LaTiO_3$), and neodymium titanate

(Nd₂Ti₂O₇), barium zirconate (BaZrO₃), calcium zirconate (CaZrO₃), lead magnesium niobate, lead zinc niobate, lithium niobate (LiNbO₃), barium stannate (BaSnO₃), calcium stannate (CaSnO₃), magnesium aluminum silicate, sodium silicate (NaSiO₃), magnesium silicate (MgSiO₃), barium tantalate (BaTa₂O₆), niobium oxide, zirconium tin titanate, silicon dioxide (SiO₂), aluminum oxide (Al₂O₃), titanium dioxide (TiO₂), and others.

[0176] As used herein, “gas generator material” means any material which will decompose at the high temperature or high voltage to produce a gas either directly from the gas generator material or indirectly from reaction of the decomposition products produced from the gas generator material with other materials contained within the battery (e.g. the electrolyte and electrodes). Non-limiting examples of gas generator materials include inorganic carbonates such as M_n(CO₃)_m, M_n(SO₃)_m, M_n(NO₃)_m, ¹M_n²M_n(CO₃)_m, NaSiO₃*H₂O, CuCO₃Cu(OH)₂, and others and organic carbonates such as polymethacrylic [-CH₂-C(CH₃)(COOM)-]_p and polyacrylate salts [-CH₂-CH(COOM)-]_p, and others wherein M, ¹M, ²M are independently selected from the group consisting of Ba, Ca, Cd, Co, Cu, Fe, K, Li, Mg, Mn, Na, Ni, Pb, Sr, and Zn; n is 1-3 and m is 1-4. In some embodiments, M is independently selected from the group consisting of an ammonium ion, pyridinium ion and a quaternary ammonium ion. In some embodiments, the gas generator material may decompose to produce a liquid (e.g. water). The liquid may react with other materials contained within the battery to form a gas and this gas will delaminate the electrode (e.g. water reacting with the electrolyte [LiFP₆] to form gaseous HF and lithium in the negative to form hydrogen gas (H₂)). If the temperature of the cell exceeds the vaporization temperature of the liquid, the liquid may also undergo a phase transition to form a gas and this gas will also delaminate the electrode.

[0177] Layers were coated onto metal foils by an automatic coating machine (compact coater, model number 3R250W-2D) produced by Thank-Metal Co., Ltd. Layers are then compressed to the desired thickness using a calender machine (model number X15-300-1-DZ) produced by Beijing Sevenstar Huachuang Electronics Co., Ltd.

EXAMPLES

[0178] The disclosure will be described more in detail below using examples, but the disclosure is not limited to the examples shown below.

Example 1

[0179] Preparation of baseline electrodes, positive and negative electrodes, and the completed Cell #1 for the evaluation in the resistance measurement, discharge capability tests at 50°C, impact test, and cycle life test are described below.

A) Preparation of POS1A as an example of the positive electrode preparation.

[0180] i) PVDF (21.6 g) was dissolved into NMP (250 g); ii) Carbon black (18 g) was added and mixed for 15 minutes at 6500 rpm; iii) $\text{LiNi}_{0.5}\text{Mn}_{0.3}\text{Co}_{0.2}\text{O}_2$ (NMC) (560.4 g) was added to the slurry from Step ii and mixed for 30 minutes at 6500 rpm to form a flowable slurry; iv) Some NMP was added for the viscosity adjustment; v) This slurry was coated onto 15 μm aluminum foil using an automatic coating machine with the first heat zone set to about 80°C and the second heat zone to about 130°C to evaporate off the NMP. The final dried solid loading was about 15.55 mg/cm^2 . The positive layer was then compressed to a thickness of about 117 μm . The electrode made here was considered as zero voltage against a standard graphite electrode and was used for the impedance measurement at 0 V in relation to the temperature, and the dry for the cell assembly.

B) Preparation of NEG2A as an example of the negative electrode preparation

[0181] i) CMC (5.2 g) was dissolved into deionized water (~300 g); ii) Carbon black (8.4 g) was added and mixed for 15 minutes at 6500 rpm; iii) Negative active graphite (JFE Chemical Corporation; Graphitized Mesophase Carbon Micro Bead (MCMB) and Synthetic Graphite (TIMCAL) (378.4g in total) were added to the slurry from Step ii and mixed for 30 minutes at 6500 rpm to form a flowable slurry; iv) SBR (solid content 50% suspended in water) (16.8 g) was added to the slurry formed in Step iii and mixed at 6500 rpm for 5 min; v) The viscosity was adjusted for a smooth coating; vi) This slurry was coated onto 9 μm thick copper foil using an automatic coating machine with the first heat zone set to about 70°C and the second heat zone to about 100°C to evaporate off the water. The final dried solid loading was about 9.14 mg/cm^2 . The negative electrode layer was then compressed to a thickness of about 117 μm . The negative made was used for the dry for the cell assembly.

C) Preparation of Cell for the evaluation

[0182] i) The electrodes were punched into the pieces with an electrode tab; ii) The positive electrode was dried at 125°C for 10 hours and negative electrode at 140°C for

10 hours; iii) The positive and negative electrodes were laminated with the separator as the middle layer; iv) The jelly-roll made in the Step iii was laid flat into an aluminum composite bag; v) The bag from Step iv. was dried in a 70°C vacuum oven; vi) The bag from Step v was filled with the LiPF₆ containing organic carbonate based electrolyte; vii) The bag from Step vi was sealed; ix) Rest for 16 hours; ix) The cell was charged to 4.2V at C/20 rate for 5 hours and then to 4.2V at 0.5C rate for 2 hours, then rest for 20 minutes, then discharged to 2.8V at 0.5C rate. Under vacuum, the cell was punctured to release any gases and then resealed. The cell made here was used for grading and other tests such as discharging capability test at 50°C, impact test, cycle life test and so on.

[0183] FIG. 15 presents the resistance in relation to the temperature increase for the positive electrode collected from autopsying a cell with 3.6 V. The resistance decreases about ten times. FIG. 18 shows the discharge capacity at the discharging currents 1, 3, 6, 10A. FIG. 20 lists the cell impedance at 1kHz and the capacity at 1A, 3A, 6A and 10A currents and the ratio of the capacity at 3, 6, 10A over that at 1A. FIG. 22 shows the cell temperature profile during the impact test. FIG. 23 summarizes the cell maximum temperature in the impact test. The cell caught the fire during the impact test. FIG. 25 shows the voltage and temperature profiles of the cells during the 12V/2A over charge test. The cell caught the fire during the over charge test (FIG. 28).

Example 2

[0184] Preparation of CaCO₃ based gas generator and resistive layer, positive and negative electrodes, and the completed Cell #3 for the evaluation in the resistance measurement, discharge capability tests at 50°C, impact test, over charge, and cycle life test are described below.

A) Positive POS3B as an example of a gas generator and resistive layer (1st layer) preparation.

[0185] i) Torlon®4000TF (0.8 g) was dissolved into NMP (10 g); ii) PVDF (4.8 g) was dissolved into NMP (~70 g); iii) The solutions prepared in Step i and ii were mixed, and then carbon black (0.32 g) was added and mixed for 10 minutes at 6500 rpm; iv) Nano CaCO₃ powder (34.08 g) was added to the solution from Step iii and mixed for 20 minutes at 6500 rpm to form a flowable slurry; v) This slurry was coated onto 15 μm thick aluminum foil using an automatic coating machine with the first heat zone set to about 135°C and the

second heat zone to about 165°C to evaporate off the NMP. The final dried solid loading was about 1 mg/cm².

B) Preparation of POS3A as an example of the positive electrode preparation (2nd layer).

[0186] i) PVDF (21.6 g) was dissolved into NMP (250 g); ii) Carbon black (18 g) was added and mixed for 15 minutes at 6500 rpm; iii) LiNi_{1/3}Co_{1/3}Mn_{1/3}O₂ (NMC) (560.4 g) was added to the slurry from Step ii and mixed for 30 minutes at 6500 rpm to form a flowable slurry; iv) Some NMP was added for the viscosity adjustment; v) This slurry was coated onto POS3B (Example 2A) using an automatic coating machine with the first heat zone set to about 85°C and the second heat zone to about 135°C to evaporate off the NMP. The final dried solid loading was about 19.4 mg/cm². The positive layer was then compressed to a thickness of about 153 μm. The electrode made here was considered as zero voltage against a standard graphite electrode and was used for the impedance measurement at 0 V in relation to the temperature.

C) Preparation of NEG3A as an example of the negative electrode preparation

[0187] i) CMC (13 g) was dissolved into deionized water (~1000 g); ii) Carbon black (20 g) was added and mixed for 15 minutes at the rate of about 6500 rpm; iii) Negative active graphite (JFE Chemical Corporation; Graphitized Mesophase Carbon Micro Bead (MCMB) and Synthetic Graphite (TIMCAL) (945.92 g in total) were added to the slurry from Step ii and mixed for 30 minutes at 6500 rpm to form a flowable slurry; iv) SBR (solid content 50% suspended in water) (42 g) was added to the slurry formed in Step iii and mixed at 6500 rpm for 5 min; v) The viscosity was adjusted for a smooth coating; vi) This slurry was coated onto 9 μm thick copper foil using an automatic coating machine with the first heat zone set to about 100°C and the second heat zone to about 130°C to evaporate off the water. The final dried solid loading was about 11.8 mg/cm². The negative electrode layer was then compressed to a thickness of about 159 μm. The negative made was used for the dry for the cell assembly.

D) Preparation of Cell for the evaluation

[0188] i) The electrodes were punched into the pieces with an electrode tab; ii) The positive electrode was dried at 125°C for 10 hours and negative electrode at 140°C for 10 hours; iii) The positive and negative electrodes were laminated with the separator as the

middle layer; iv) The jelly-roll made in the Step iii was laid flat in an aluminum composite bag; v) The bag from Step iv was dried in a 70°C vacuum oven; vi) The bag from Step v was filled with the LiPF₆ containing organic carbonate based electrolyte; vii) The bag from Step vi was sealed; viii) Rest for 16 hours; ix) The cell was charged to 4.2V at C/50 rate for 8 hours and then to 4.2V at 0.5C rate for 2 hours, then rest for 20 minutes, then discharged to 2.8V at 0.5C rate; x) Under vacuum, the cell was punctured to release any gases and then resealed. The cell made here was used for grading and other tests such as discharging capability test at 50°C, impact test, cycle life test and so on.

[0189] FIG. 16 presents the resistance in relation to the temperature increase for the positive electrode collected from autopsying cells with 0, 3.6, and 4.09 V. The resistance increases with the increase in the temperature, especially for the positive electrodes obtained from the cell having the voltages 3.66 and 4V. FIG. 19 shows the discharge capacity at 1, 3, and 6A current and at 50°C. The cell capacity decreases significantly with the increase of the current, indicating the strong effect from the resistive layer. FIG. 20 lists the cell impedance at 1kHz and the capacity at 1A, 3A, 6A and 10A currents and the ratio of the capacity at 3, 6, 10A over that at 1A. FIG. 26 presents the over charge profiles during the over charge test. FIG. 28 summarize the cell maximum temperature during the over charge test and residual current in the end of over charge test. FIG. 29 shows the discharge capacity vs. the cycle number. The cell lost about 1% capacity that is about 100% better than that (2.5%) of the baseline cell. FIG. 22 shows the cell temperature profiles during the impact test. FIG. 23 summarizes the cell maximum temperature in the impact test.

Example 3

[0190] Preparation of 50% Al₂O₃ and 50% CaCO₃ based gas generator and resistive layer, positive and negative electrodes, and the completed Cell #4 for the evaluation in the resistance measurement, discharge capability tests at 50°C, impact test, over charge and cycle life tests are described below.

A) Positive POS4B as an example of a gas generator and resistive layer (1st layer) preparation.

[0191] i) Torlon®4000TF (0.8 g) was dissolved into NMP (10 g); ii) PVDF (4.8 g) was dissolved into NMP (~70 g); iii) The solutions prepared in Step i and ii were mixed, and then carbon black (0.32 g) was added and mixed for 10 minutes at 6500 rpm; iv) Nano CaCO₃ powder (17.04 g) and Al₂O₃ powder (17.04g) were added to the solution from Step iii

and mixed for 20 minutes at 6500 rpm to form a flowable slurry; v) This slurry was coated onto 15 μm thick aluminum foil using an automatic coating machine with the first heat zone set to about 135°C and the second heat zone to about 165°C to evaporate off the NMP. The final dried solid loading was about 1 mg/cm^2 .

B) Preparation of POS4A as an example of the positive electrode preparation (2nd layer).

[0192] i) PVDF (21.6 g) was dissolved into NMP (250 g); ii) Carbon black (18 g) was added and mixed for 15 minutes at the rate of about 6500 rpm; iii) $\text{LiNi}_{1/3}\text{CO}_{1/3}\text{Mn}_{1/3}\text{O}_2$ (NMC) (560.4 g) was added to the slurry from Step ii and mixed for 30 minutes at 6500 rpm to form a flowable slurry; iv) Some NMP was added for the viscosity adjustment; v) This slurry was coated onto POS4B (Example 3A) using an automatic coating machine with the first heat zone set to about 85°C and the second heat zone to about 135°C to evaporate off the NMP. The final dried solid loading was about 19.4 mg/cm^2 . The positive layer was then compressed to a thickness of about 153 μm . The electrode made here was considered as zero voltage against a standard graphite electrode and was used for the impedance measurement at 0 V in relation to the temperature.

C) Preparation of NEG4A as an example of the negative electrode preparation

[0193] i) CMC (13 g) was dissolved into deionized water (~1000 g); ii) Carbon black (20 g) was added and mixed for 15 minutes at 6500 rpm; iii) Negative active graphite (JFE Chemical Corporation; Graphitized Mesophase Carbon Micro Bead (MCMB) and Synthetic Graphite (TIMCAL) (945.92 g in total) were added to the slurry from Step ii and mixed for 30 minutes at 6500 rpm to form a flowable slurry; iv) SBR (solid content 50% suspended in water) (42 g) was added to the slurry formed in Step iii and mixed at about 6500 rpm for 5 min; v) The viscosity was adjusted for a smooth coating; vi) This slurry was coated onto 9 μm thick copper foil using an automatic coating machine with the first heat zone set to about 100°C and the second heat zone to about 130°C to evaporate off the water. The final dried solid loading was about 11.8 mg/cm^2 . The negative electrode layer was then compressed to a thickness of about 159 μm . The negative made was used for the dry for the cell assembly.

D) Preparation of Cell for the evaluation

[0194] i) The electrodes were punched into the pieces with an electrode tab; ii) The positive electrode was dried at 125°C for 10 hours and negative electrode at 140°C for 10

hours; iii) The positive and negative electrodes were laminated with the separator as the middle layer; iv) The jelly-roll made in the Step iii was laid flat in an aluminum composite bag; v) The bag from Step iv was dried in a 70°C vacuum oven; vi) The bag from Step v was filled with the LiPF₆ containing organic carbonate based electrolyte; vii) The bag from Step vi was sealed; viii) Rest for 16 hours; ix) The cell was charged to 4.2V at C/50 rate for 8 hours and then to 4.2V at 0.5C rate for 2 hours, then rest for 20 minutes, then discharged to 2.8V at 0.5C rate; x) Under vacuum, the cell was punctured to release any gases and then resealed. The cell made here was used for grading and other tests such as discharging capability test at 50°C, impact test, cycle life test and so on.

[0195] FIG. 20 lists the cell impedance at 1 kHz and the capacity at 1A, 3A, 6A and 10A currents and the ratio of the capacity at 3A, 6A, and 10A over that at 1A. FIG. 22 shows the cell temperature profiles during the impact test. FIG. 23 summarizes the cell maximum temperature in the impact test. FIG. 26 shows the voltage profiles of the cell voltage and temperature during the 12V/2A over charge test. FIG. 28 summarizes the cell maximum cell temperatures in the over charge test.

Example 4

[0196] Preparation of Al₂O₃ and Sodium trisilicate (NaSiO₃) mixed based gas generator and resistive layer, positive and negative electrodes, and the completed Cell #5 for the evaluation in the resistance measurement, discharge capability tests at 50°C, impact test, over charge, and cycle life tests are described below.

A) Positive POS5B as an example of a gas generator and resistive layer (1st layer) preparation.

[0197] i) Torlon®4000TF (0.8 g) was dissolved into NMP (~10 g); ii) PVDF (4.8 g) was dissolved into NMP (60 g); iii) The solutions prepared in Step i and ii were mixed, and then carbon black (0.32 g) was added and mixed for 10 minutes at 6500 rpm; iv) Nano Al₂O₃ powder (17.04 g) and NaSiO₃ (17.04g) were added to the solution from Step iii and mixed for 20 minutes at 6500 rpm to form a flowable slurry; v) This slurry was coated onto 15 μm thick aluminum foil using an automatic coating machine with the first heat zone set to about 135°C and the second heat zone to about 165°C to evaporate off the NMP. The final dried solid loading was about 0.7 mg/cm².

B) Preparation of POS5A as an example of the positive electrode preparation (2nd layer).

[0198] i) PVDF (21.6 g) was dissolved into NMP (270 g); ii) Carbon black (18 g) was added and mixed for 15 minutes at the rate of about 6500 rpm; iii) $\text{LiNi}_{1/3}\text{Co}_{1/3}\text{Mn}_{1/3}\text{O}_2$ (NMC) (560.4 g) was added to the slurry from Step ii and mixed for 30 minutes at the rate of about 6500 rpm to form a flowable slurry; iv) Some NMP was added for the viscosity adjustment; v) This slurry was coated onto POS5B (Example 4A) using an automatic coating machine with the first heat zone set to about 85°C and the second heat zone to about 135°C to evaporate off the NMP. The final dried solid loading was about 19.4 mg/cm². The positive layer was then compressed to a thickness of about 153 μm. The electrode made here was considered as zero voltage against a standard graphite electrode and was used for the impedance measurement at 0 V in relation to the temperature.

C) Preparation of NEG5A as an example of the negative electrode preparation

[0199] i) CMC (13 g) was dissolved into deionized water (~1000 g); ii) Carbon black (20 g) was added and mixed for 15 minutes at the rate of about 6500 rpm; iii) Negative active graphite (JFE Chemical Corporation; Graphitized Mesophase Carbon Micro Bead (MCMB) and Synthetic Graphite (TIMCAL) (945.92 g in total) were added to the slurry from Step ii and mix for 30 minutes at 6500 rpm to form a flowable slurry; iv) SBR (solid content 50% suspended in water) (42 g) was added to the slurry formed in Step iii and mixed at 6500 rpm for 5 min; v) The viscosity was adjusted for a smooth coating; vi) This slurry was coated onto 9 μm thick copper foil using an automatic coating machine with the first heat zone set to about 100°C and the second heat zone to about 130°C to evaporate off the water. The final dried solid loading was about 11.8 mg/cm². The negative electrode layer was then compressed to a thickness of about 159 μm. The negative made is ready for the dry for the cell assembly.

D) Preparation of Cell for the evaluation

[0200] i) The electrodes were punched into the pieces with an electrode tab; ii) The positive electrode was dried at 125°C for 10 hours and negative electrode at 140°C for 10 hours; iii) The positive and negative electrodes were laminated with the separator as the middle layer; iv) The jelly-roll made in the Step iii was laid flat in an aluminum composite bag; v) The bag from Step iv. was dried in a 70°C vacuum oven; vi) The bag from Step v was filled with the LiPF_6 containing organic carbonate based electrolyte; vii) The bag from Step

vi) was sealed; viii) Rest for 16 hours; ix) The cell was charged to 4.2V at C/50 rate for 8 hours and then to 4.2V at 0.5C rate for 2 hours, then rest for 20 minutes, then discharged to 2.8V at 0.5C rate. x) Under vacuum, the cell was punctured to release any gases and then resealed. The cell made here was used for grading and other tests such as discharging capability test at 50°C, impact test, cycle life test and so on.

[0201] FIG. 18 lists the cell impedance at 1 kHz and the capacity at 1A, 3A, 6A and 10A currents and the ratio of the capacity at 3, 6, and 10A over that at 1A. FIG. 22 shows the cell temperature profiles during the impact test FIG. 23 summarizes the cell maximum temperature in the impact test. FIG. 28 summarizes the cell maximum temperature in the 12V/2A overcharge test.

Example 5

[0202] Preparation of 52% CaCO₃ and 48% PVDF based gas generator and resistive layer, positive and negative electrodes, and the completed Cell #6 for the evaluation in the resistance measurement, discharge capability tests at 50°C, impact test, over charge, and cycle life tests are discussed below.

A) Positive POS6B as an example of a gas generator and resistive layer (1st layer) preparation.

[0203] i) PVDF (23.25 g) was dissolved into NMP (~250 g); ii) The solution prepared in Step I was mixed, and then carbon black (1.85 g) was added and mixed for 10 minutes at the rate of about 6500 rpm; iv) Nano CaCO₃ powder (24.9 g) was added to the solution from Step iii and mixed for 20 minutes at 6500 rpm to form a flowable slurry; v) This slurry was coated onto 15 μm thick aluminum foil using an automatic coating machine with the first heat zone set to about 135°C and the second heat zone to about 165°C to evaporate off the NMP. The final dried solid loading was about 1 mg/cm².

B) Preparation of POS6A as an example of the positive electrode preparation (2nd layer).

[0204] i) PVDF (24 g) was dissolved into NMP (300 g); ii) Carbon black (12 g) was added and mixed for 15 minutes at 6500 rpm; iii) LiNi_{0.4}Co_{0.3}Mn_{0.4}Co_{0.3}O₂ (NMC) (558 g) was added to the slurry from Step ii and mixed for 30 minutes at 6500 rpm to form a flowable slurry; iv) Some NMP was added for the viscosity adjustment; v) This slurry was coated onto POS6B (Example 5A) using an automatic coating machine with the first heat

zone set to about 85°C and the second heat zone to about 135°C to evaporate off the NMP. The final dried solid loading was about 22 mg/cm². The positive layer was then compressed to a thickness of about 167 μm. The electrode made here was considered as zero voltage against a standard graphite electrode and was used for the impedance measurement at 0 V in relation to the temperature.

C) Preparation of NEG6A as an example of the negative electrode preparation.

[0205] i) CMC (9 g) was dissolved into deionized water (~530 g); ii) Carbon black (12 g) was added and mixed for 15 minutes at 6500 rpm; iii) Negative active graphite (JFE Chemical Corporation; Graphitized Mesophase Carbon Micro Bead (MCMB) (564 g) were added to the slurry from Step ii and mixed for 30 minutes at 6500 rpm to form a flowable slurry; iv) SBR (solid content 50% suspended in water) (30 g) was added to the slurry formed in Step iii and mixed at about 6500 rpm for 5 min; v) Some water was added to adjust the viscosity for a smooth coating; vi) This slurry was coated onto 9 μm thick copper foil using an automatic coating machine with the first heat zone set to about 95°C and the second heat zone to about 125°C to evaporate off the water. The final dried solid loading was about 12 mg/cm². The negative electrode layer was then compressed to a thickness of about 170 μm. The negative made was used for the dry for the cell assembly.

D) Preparation of Cell for the evaluation.

[0206] i) The electrodes were punched into the pieces with an electrode tab; ii) The positive electrode was dried at 125°C for 10 hours and negative electrode at 140°C for 10 hours; iii) The positive and negative electrodes were laminated with the separator as the middle layer; iv) The jelly-roll made in the Step iii was laid flat in an aluminum composite bag; v) The bag from Step iv was dried in a 70°C vacuum oven; vi) The bag from Step v was filled with the LiPF₆ containing organic carbonate based electrolyte; vii) The bag from Step vi was sealed; viii) Rest for 16 hours; ix) The cell was charged to 4.2V at C/50 rate for 8 hours and then to 4.2V at 0.5C rate for 2 hours, then rest for 20 minutes, then discharged to 2.8V at 0.5C rate. x) Under vacuum, the cell was punctured to release any gases and then resealed. The cell made here was used for grading and other tests such as discharging capability test at 50°C, impact test, cycle life test and so on.

[0207] FIG. 20 lists the cell impedance at 1kHz and the capacity at 1A, 3A, 6A and 10A currents and the ratio of the capacity at 3, 6, 10A over that at 1A. FIG. 22 shows the cell temperature profiles during the impact test. FIG. 23 summarizes the cell maximum

temperature in the impact test. FIG. 28 summarizes the cell maximum cell temperatures in the over charge test.

Example 6

[0208] Preparation of positive electrodes for chemical decomposition voltage measurements is described below.

[0209] POS7B was prepared as follows: (i) Deionized water (~300 g) was mixed into Carbopol[®]-934 (19.64 g); (ii) Super-P[®] (160 mg) and LiOH (200 mg) were added into the slurry made in Step (i) and mixed for 30 minutes at 5000 rpm; (iii) An appropriate amount of deionized water was added to adjust the slurry to form a coatable slurry. (iv) The slurry was coated onto a 15 μm aluminum foil with the automatic coating machine with the drying temperatures set to 135°C for zone 1 and 165°C for zone 2. The final dried solid loading was about 0.7 mg/cm².

[0210] POS8B was prepared as follows: (i) Deionized water (-100 g) was mixed into AI-50 (19.85 g); (ii) Super-P[®] (160 mg) was added into the slurry made in Step (i) and mixed for 30 minutes at 5000 rpm; (iii) An appropriate amount of deionized water was added to adjust the slurry to form a coatable slurry. (iv) The slurry was coated onto 15 μm aluminum foil with automatic coating machine with the drying temperatures set to 135 for zone 1 and 165°C for zone 2. The final dried solid loading was about 0.7 mg/cm².

[0211] POS9B was prepared as follows: (i) Deionized water (~322 g) was mixed into 19.85g CMC-DN-800H; (ii) Super-P[®] (160 mg) was added into the slurry made in Step (i) and mixed for 30 minutes at 5000 rpm; (iii) An appropriate amount of deionized water was added to adjust the slurry to form a coatable slurry. (iv) The slurry was coated onto 15 μm aluminum foil with automatic coating machine with the drying temperatures set to 135 for zone 1 and 165°C for zone 2. The final dried solid loading was about 0.7 mg/cm².

[0212] POS13B was prepared as follows: (i) Torlon[®]4000TF (400 mg) was dissolved into NMP (4 g). (ii) PVDF-A (2.4 g) was dissolved into NMP (30 g). (iii) The two solutions were mixed and Super-P[®] (160 mg) was added, then mixed for 30 minutes at 5000 rpm. (iv) La₂(CO₃)₃ (17.04 g) or the salts listed in FIG. 8 were added into above slurry and mixed together at 5000 rpm for 30 min. (v) The slurry was coated onto 15 μm aluminum foil with automatic coating machine at first heat zone set to 13°C and second heat zone to 16°C for evaporate off the NMP. Final dried solid loading was about 0.7 mg/cm².

Example 7

[0213] Electrochemical test for the positives electrodes coated with gas generator layers is described below.

[0214] The decomposition voltages of all resistive layers were measured with a three electrode configuration (resistive layer as the working electrode, and lithium metal as both reference electrode and count electrode) by Linear Sweep Voltammetry technology using a VMP2 multichannel potentiostat instrument at room temperature. A 0.3 cm X 2.0 cm piece of the resistive layer was the working electrode, and 0.3 cm X 2.0 cm piece of lithium metal was both reference electrode and counter electrode. These electrodes were put into a glass containing LiPF_6 ethylene carbonate based electrolyte (5 g). The scan rate is 5mV/second in the voltage range from 0 to 6V. FIG. 31 and 33 shows the decomposition voltage profiles of these compounds. FIG. 32 and 34 summarizes the peak current and peak voltage for each of the compounds tested.

Example 8

[0215] Preparation of CaCO_3 based gas generator layer, positive and negative electrodes, and the cell (#7) for the evaluation in the over charge test is described below. This gas generator layer could become a resistive layer if the conductive additive content is in the certain range such that the resistivity of the gas-generator layer is more resistive (50% more at least) than that of the energy layer or the layer that provide the majority (>50%) of the battery discharge energy. The gas generator content can be 2% to 99%.

A) Positive POS071A as an example of a gas generator layer (1st layer) preparation.

[0216] i) Torlon[®] 4000TF (0.9 g) was dissolved into NMP (10 g); ii) PVDF (5.25 g) was dissolved into NMP (~68 g); iii) The solutions prepared in Step i and ii were mixed, and then carbon black (1.8 g) was added and mixed for 10 min at the rate of about 6500 rpm; iv) Nano CaCO_3 powder (7.11 g) and 134.94g $\text{LiNi}_{0.33}\text{Al}_{0.33}\text{Co}_{0.33}\text{O}_2$ were added to the solution from Step iii and mixed for 20 min at the rate of about 6500 rpm to form a flowable slurry; v) This slurry was coated onto 15 μm thick aluminum foil using an automatic coating machine with the first heat zone set to about 90°C and the second heat zone to about 140°C to evaporate off the NMP. The final dried solid loading was about 4mg/cm².

B) Preparation of POS071B as an example of the positive electrode preparation (2nd layer).

[0217] i) PVDF (25.2 g) was dissolved into NMP (327 g); ii) Carbon black (21 g) was added and mixed for 15 min at the rate of about 6500 rpm; iii) $\text{LiNi}_{0.82}\text{Al}_{0.03}\text{Co}_{0.15}\text{O}_2$

(NCA) (649 g) was added to the slurry from Step ii and mixed for 30 min at the rate of about 6500 rpm to form a flowable slurry; iv) Some NMP was added for the viscosity adjustment; v) This slurry was coated onto POS071A using an automatic coating machine with the first heat zone set to about 85°C and the second heat zone to about 135°C to evaporate off the NMP. The final dried solid loading is about 20.4 mg/cm². The positive layer was then compressed to a thickness of about 155 μm.

C) Preparation of NEG015B as an example of the negative electrode preparation

[0218] i) CMC (15 g) was dissolved into deionized water (~951 g); ii) Carbon black (15 g) was added and mixed for 15 min at the rate of about 6500 rpm; iii) Negative active graphite (JFE Chemical Corporation; Graphitized Mesophase Carbon Micro Bead (MCMB) (945 g) was added to the slurry from Step ii and mixed for 30 min at the rate of about 6500 rpm to form a flowable slurry; iv) SBR (solid content 50% suspended in water) (50 g) was added to the slurry formed in Step iii and mixed at about 6500 rpm for 5 min; v) The viscosity was adjusted for a smooth coating; vi) This slurry was coated onto 9 μm thick copper foil using an automatic coating machine with the first heat zone set to about 100°C and the second heat zone to about 130°C to evaporate off the water. The final dried solid loading was about 11 mg/cm². The negative electrode layer was then compressed to a thickness of about 155 μm. The negative made is ready for the dry for the cell assembly.

D) Preparation of Cell for the evaluation

[0219] i) The electrodes were punched into the pieces with an electrode tab; ii) The positive electrode was dried at ~125°C for 10 hr and negative electrode at ~140°C for 10 hr; iii) The positive and negative electrodes were laminated with the separator as the middle layer; iv) The jelly-roll made in the Step iii was laid flat in an aluminum composite bag; v) The bag from Step iv. was dried in a 70°C vacuum oven; vi) The bag from Step v was filled with the carbonate based electrolyte; vii) The bag from Step vi was sealed; viii) Rest for 16 hours; ix) The cell was charged to 4.2V at C/50 rate for 8 hours and then to 4.2V at 0.5C rate for 2 hours, then rest for 20 minutes, then discharged to 2.8V at 0.5C rate. The cell made here was used for grading and other tests such as over charge test.

[0220] FIG. 35 presents the overcharge voltage, cell temperature and oven chamber temperature during the overcharge test (2A and 12V). The cell passed the over test nicely since the cell maximum temperature is about 83°C during the overcharge test.

Implementations of the current subject matter can include, but are not limited to, articles of manufacture (e.g. apparatuses, systems, etc.), methods of making or use, compositions of matter, or the like consistent with the descriptions provided herein.

Example 9

[0221] Preparation of Al₂O₃ based resistive layer, positive and negative electrodes, and the completed Cell 3 for the evaluation in the resistance measurement, discharge capability tests at 50° C, impact test, and cycle life test are described below.

A) Positive POS3B as an example of a resistance layer (1st layer) preparation.

[0222] i) Dissolve Torlon[®] 4000TF (1 g) into NMP (10 g); Dissolve PVDF (6 g) into NMP (70 g); iii) Mix solution prepared in Step i and ii, and then add carbon black (0.4 g) and mix for 10 min at 6500 rpm; iv) Add nano Al₂O₃ powder (42 g) to the solution from Step iii and mix for 20 min at the rate of 6500 rpm to form a flowable slurry; v) Coat this slurry onto 15 μm thick aluminum foil using an automatic coating machine with the first heat zone set to about 130°C and the second heat zone to about 160°C to evaporate off the NMP. The final dried solid loading is about 1 mg/cm².

B) Preparation of POS3A as an example of the positive electrode preparation (2nd layer).

[0223] i) PVDF (21.6 g) was dissolved into NMP (250 g); Carbon black (18 g) was added and mixed for 15 min at 6500 rpm; LiNi_{1/3}Co_{1/3}Mn_{1/3}O₂ (NMC) (560.4 g) was added to the slurry from Step ii and mixed for 30 min at 6500 rpm to form a flowable slurry; iv) Some NMP was added for the viscosity adjustment; v) This slurry was coated onto POS3B using an automatic coating machine with the first heat zone set to about 85°C and the second heat zone to about 135°C to evaporate off the NMP. The final dried solid loading was about 19.4 mg/cm². The positive layer was then compressed to a thickness of about 153 μm. The electrode made here is called as zero voltage against a standard graphite electrode and was used for the impedance measurement at 0 V in relation to the temperature.

C) Preparation of NEG3A as an example of the negative electrode preparation

[0224] i) CMC (13 g) was dissolved into deionized water (~1000 g); ii) Carbon black (20 g) was added and mixed for 15 min at 6500 rpm; iii) Negative active graphite (JFE Chemical Corporation; Graphitized Mesophase Carbon Micro Bead (MCMB) and Synthetic Graphite (TIMCAL) (945.92 g in total) was added to the slurry from Step ii and mixed for 30 min at 6500 rpm to form a flowable slurry; iv) SBR (solid content 50% suspended in water)

(42 g) was added to the slurry formed in Step iii and mixed at 6500 rpm for 5 min; v) The viscosity was adjusted for a smooth coating; vi) This slurry was coated onto 9 gm thick copper foil using an automatic coating machine with the first heat zone set to about 100°C and the second heat zone to about 130°C to evaporate off the water. The final dried solid loading was about 11.8 mg/cm². The negative electrode layer was then compressed to a thickness of about 159 μm. The negative made was used for the dry for the cell assembly.

D) Preparation of Cell for the evaluation

[0225] i) The electrodes were punched into the pieces with the electrode tab; ii) The positive electrode was dried at 125°C for 10 hours and negative electrode at 140°C for 10 hours; iii) The positive and negative electrodes were laminated with the separator as the middle layer; iv) The flat jelly-roll made in the Step iii. was laid flat into an aluminum composite bag; v) The bag from Step iv. was dried in a 70°C vacuum oven; vi) The bag from Step v was filled with the LiPF₆ containing organic carbonate based electrolyte; vii) The bag from Step vi was sealed; viii) Rested for 16 hours; ix) The cell was charged to 4.2V at C/50 rate for 8 hours and then to 4.2V at 0.5C rate for 2 hours, then rest for 20 minutes, then discharged to 2.8V at 0.5C rate. Under vacuum, the cell was punctured to release any gases and then resealed. The cell made here was used for grading and other tests such as discharging capability test at 50°C, impact test, cycle life test and so on.

[0226] FIG. 38 presents the resistance in relation to the temperature increase for the positive electrode collected from autopsying a cell with 4.09V. The resistance changes very little compared with that (FIG. 37) of the baseline cell. FIG. 42 shows the discharge capacity vs. the cycle number. The cell lost about 2% capacity that is similar to that (2.5%) of the baseline cell. FIG. 36 lists the cell impedance at 1 kHz and the capacity at 1A, 3A, 6A and 10A currents and the ratio of the capacity at 3A, 6A, 10A over that at 1A. FIG. 40 shows the cell temperature profiles during the impact test. FIG. 41 summarizes the cell maximum temperature in the impact test.

Example 10

[0227] Preparation of 50% Polyacrylic latex and 50% Barium Titanate (BaTiO_2) based resistive layer, positive and negative electrodes, and the completed Cell 4 for the evaluation in the resistance measurement, discharge capability tests at 50°C , impact test, and cycle life test are described below.

A) Positive POS4B as an example of a resistance layer (1st layer) preparation.

[0228] i) CMC (0.375 g) was dissolved into deionized water (~30 g); ii) The solution prepared in Step i was mixed, and then carbon black (1.75 g) was added and mixed for several minutes; iii) nano BaTiO_2 powder (25 g) was added to the solution from Step ii and mixed for 20 min at 6500 rpm to form a flowable slurry; v) This slurry was coated onto 15 μm thick aluminum foil using an automatic coating machine with the first heat zone set to about 90°C and the second heat zone to about 140°C to evaporate off the water. The final dried solid loading was about 0.7 mg/cm^2 .

B) Preparation of POS4A as an example of the positive electrode preparation (2nd layer).

[0229] i) PVDF (14.4 g) was dissolved into NMP (~160 g); ii) Carbon black (12 g) was added and mixed for 15 min at 6500 rpm; iii) $\text{LiNi}_{0.5}\text{Mn}_{0.3}\text{Co}_{0.2}\text{O}_2$ (NMC) (373.6 g) was added to the slurry from Step ii and mixed for 30 min at 6500 rpm to form a flowable slurry; iv) Some NMP was added for the viscosity adjustment; v) This slurry was coated onto POS4B (Example 2A) using an automatic coating machine with the first heat zone set to about 80°C and the second heat zone to about 130°C to evaporate off the NMP. The final dried solid loading was about 15.2 mg/cm^2 . The positive layer was then compressed to a thickness of about 113 μm . The electrode made here was called as zero voltage against a standard graphite electrode and was used for the impedance measurement at 0 V in relation to the temperature.

C) Preparation of NEG3A as an example of the negative electrode preparation

[0230] i) CMC (7.8 g) was dissolved into deionized water (~800 g); ii) Carbon black (12 g) was added and mixed for 15 min at 6500 rpm; iii) Negative active graphite (JFE Chemical Corporation; Graphitized Mesophase Carbon Micro Bead (MCMB) and Synthetic Graphite (TIMCAL) (568.6 g in total) was added to the slurry from Step ii and mixed for 30 min at 6500 rpm to form a flowable slurry; iv) SBR (solid content 50% suspended in water)

(25.2 g) was added to the slurry formed in Step iii and mixed at 6500 rpm for 5 min; v) The viscosity was adjusted for a smooth coating; vi) This slurry was coated onto 9 μm thick copper foil using an automatic coating machine with the first heat zone set to about 70°C and the second heat zone to about 100°C to evaporate off the water. The final dried solid loading was about 8.99 mg/cm². The negative electrode layer was then compressed to a thickness of about 123 μm . The negative made was used for the dry for the cell assembly.

D) Preparation of Cell for the evaluation

[0231] i) The electrodes were punched into the pieces with an electrode tab; ii) The positive electrode was dried at 125°C for 10 hours and negative electrode at 140°C for 10 hours; iii) The positive and negative electrodes were laminated with the separator as the middle layer; iv) The flat jelly-roll made in the Step iii. was laid flat into the aluminum composite bag; v) The bag from Step iv. was dried in a 70°C vacuum oven; vi) The bag from Step v was filled with the LiPF₆ containing organic carbonate based electrolyte; vii) The bag from Step vi was sealed; viii) Rest for 16 hours; ix) The cell was charged to 4.2V at C/50 rate for 8 hours and then to 4.2V at 0.5C rate for 2 hours, then rest for 20 minutes, then discharged to 2.8V at 0.5C rate. Under vacuum, the cell was punctured to release any gases and then resealed. The cell made here was used for grading and other tests such as discharging capability test at 50°C, impact test, cycle life test and so on.

[0232] FIG. 39 shows the discharge capacity at 1A, 3A, 6A current and at 50°C. The cell capacity decreases very rapidly with the increase of the current, indicating the strong effect from the resistive layer. FIG. 36 lists the cell impedance at 1 kHz and the capacity at 1A, 3A, 6A and 10A currents and the ratio of the capacity at 3A, 6A, 10A over that at 1A. FIG. 40 shows the cell temperature profiles during the impact test. FIG. 41 summarizes the cell maximum temperature in the impact test.

Example 11

[0233] Preparation of resistive layer in negative electrodes, positive and negative electrodes, and the completed Cell 5 for the evaluation in the resistance measurement, discharge capability tests at 50°C, impact test, and cycle life test are described below.

A) Preparation of POS5A as an example of the positive electrode preparation.

[0234] i) PVDF (31.5 g) was dissolved into NMP (~340 g); ii) Carbon black (13.5 g) was added and mixed for 15 min at 6500 rpm; iii) $\text{LiNi}_{0.33}\text{Mn}_{0.33}\text{Co}_{0.33}\text{O}_2$ (NMC) (855 g) was added to the slurry from Step ii and mix for 30 min at 6500 rpm to form a flowable slurry; iv) Some NMP was added for the viscosity adjustment; v) This slurry was added onto 15 μm aluminum foil using an automatic coating machine with the first heat zone set to about 80°C and the second heat zone to about 130°C to evaporate off the NMP. The final dried solid loading was about 14.8 mg/cm^2 . The positive layer was then compressed to a thickness of about 113 μm . The electrode made here was designated as zero voltage against a standard graphite electrode and was used for the impedance measurement at 0 V in relation to the temperature, and the dry for the cell assembly.

B) Preparation of NEG5B as an example of the negative electrode preparation (1st layer)

[0235] CMC (0.375 g) was dissolved into deionized water (~90 g); ii) Carbon black (1.75 g) was added and mixed for 15 min; BaTiO_2 (25g in total) was added to the slurry from Step ii and mixed for 30 min at 6500 rpm to form a flowable slurry; iv) SBR (solid content 50% suspended in water) (45.6 g) was added to the slurry formed in Step iii and mixed at about 6500 rpm for 5 min; v) The viscosity was adjusted for a smooth coating; vi) This slurry was coated onto 9 μm thick copper foil using an automatic coating machine with the first heat zone set to about 90°C and the second heat zone to about 140°C to evaporate off the water.

C) Preparation of NEG5A as an example of the negative electrode preparation (2nd layer)

[0236] i) CMC (3.9 g) was dissolved into deionized water (~350 g); ii) Carbon black (6 g) was added and mixed for 15 min at 6500 rpm; iii) Negative active graphite (JFE Chemical Corporation; Graphitized Mesophase Carbon Micro Bead (MCMB) and Synthetic Graphite (TIMCAL) (283.8g in total) were added to the slurry from Step ii and mixed for 30 min at 6500 rpm to form a flowable slurry; iv) SBR (solid content 50% suspended in water)

(25.2 g) was added to the slurry formed in Step iii and mixed at 6500 rpm for 5 min; v) The viscosity was adjusted for a smooth coating; vi) This slurry was coated onto NEG5B (Example 4B) using an automatic coating machine with the first heat zone set to about 70°C and the second heat zone to about 100°C to evaporate off the water. The final dried solid loading was about 9.8 mg/cm². The negative electrode layer was then compressed to a thickness of about 114 μm. The negative made was used for the dry for the cell assembly.

D) Preparation of Cell for the evaluation

[0237] i) The electrodes were punched into the pieces with the electrode tab; ii) The positive electrode was dried at 125°C for 10 hours and negative electrode at 140°C for 10 hours; iii) The positive and negative electrodes were laminated with the separator as the middle layer; iv) The flat jelly-roll made in the Step iii. was laid flat into the aluminum composite bag; v) The bag from Step iv. was dried in a 70°C vacuum oven; vi) The bag from Step v was filled with the LiPF₆ containing organic carbonate based electrolyte; vii) The bag from Step vi was sealed; viii) Rest for 16 hours; ix) The cell was charged to 4.2V at C/20 rate for 5 hours and then to 4.2V at 0.5C rate for 2 hours, then rest for 20 minutes, then discharged to 2.8V at 0.5C rate. Under vacuum, the cell was punctured to release any gases and then resealed. The cell made here was used for grading and other tests such as discharging capability test at 50°C, impact test, cycle life test and so on.

[0238] FIG. 36 lists the cell impedance at 1 kHz and the capacity at 1A, 3A, 6A and 10A currents and the ratio of the capacity at 3A, 6A, 10A over that at 1A. FIG. 40 shows the cell temperature profile during the impact test. FIG. 41 summarizes the cell maximum temperature in the impact test.

Example 12

[0239] Preparation of Al₂O₃ and Sodium trisilicate (NaSiO₃) mixed based resistive layer, positive and negative electrodes, and the completed Cell 6 for the evaluation in the resistance measurement, discharge capability tests at 50°C, impact test, and cycle life test are described below.

A) Positive POS6B as an example of a resistance layer (1st layer) preparation.

[0240] i) Torlon[®]4000TF (0.8 g) was dissolved into NMP (~10 g); ii) PVDF (4.8 g) was dissolved into NMP (60 g); iii) The solutions prepared in Step i and ii were mixed, and then carbon black (0.32 g) was added and mixed for 10 min at 6500 rpm; iv) nano Al₂O₃

powder (17.04 g) and NaSiO_3 (17.04g) were added to the solution from Step iii and mixed for 20 min at 6500 rpm to form a flowable slurry; v) This slurry was coated onto 15 μm thick aluminum foil using an automatic coating machine with the first heat zone set to about 135°C and the second heat zone to about 165°C to evaporate off the NMP. The final dried solid loading was about 0.7mg/cm².

B) Preparation of POS6A as an example of the positive electrode preparation (2nd layer).

[0241] i) PVDF (21.6 g) was dissolved into NMP (270 g); ii) Carbon black (18 g) was added and mixed for 15 min at 6500 rpm; iii) $\text{LiNi}_{1/3}\text{Co}_{1/3}\text{Mn}_{1/3}\text{O}_2$ (NMC) (560.4 g) was added to the slurry from Step ii and mixed for 30 min at 6500 rpm to form a flowable slurry; iv) Some NMP was added for the viscosity adjustment; v) This slurry was coated onto POS6B (Example 1A) using an automatic coating machine with the first heat zone set to about 85°C and the second heat zone to about 135°C to evaporate off the NMP. The final dried solid loading was about 19.4 mg/cm². The positive layer was then compressed to a thickness of about 153 μm . The electrode made here was called as zero voltage against a standard graphite electrode and was used for the impedance measurement at 0 V in relation to the temperature.

C) Preparation of NEG6A as an example of the negative electrode preparation

[0242] i) CMC (13 g) was dissolved into deionized water (~1000 g); ii) Carbon black (20 g) was added and mixed for 15 min at 6500 rpm; iii) Negative active graphite (JFE Chemical Corporation; Graphitized Mesophase Carbon Micro Bead (MCMB) and Synthetic Graphite (TIMCAL) (945.92 g in total) were added to the slurry from Step ii and mix for 30 min at 6500 rpm to form a flowable slurry; iv) SBR (solid content 50% suspended in water) (42 g) was added to the slurry formed in Step iii and mixed at 6500 rpm for 5 min; v) The viscosity was adjusted for a smooth coating; vi) This slurry was coated onto 9 μm thick copper foil using an automatic coating machine with the first heat zone set to about 100°C and the second heat zone to about 130°C to evaporate off the water. The final dried solid loading was about 11.8 mg/cm². The negative electrode layer was then compressed to a thickness of about 159 μm . The negative made is ready for the dry for the cell assembly.

D) Preparation of Cell for the evaluation

[0243] i) The electrodes were punched into the pieces with an electrode tab; ii) The positive electrode was dried at 125°C for 10 hours and negative electrode at 140°C for 10 hours; iii) The positive and negative electrodes were laminated with the separator as the middle layer; iv) The flat jelly-roll made in the Step iii. was put into an aluminum composite bag; v) The bag from Step iv. was dried in a 70°C vacuum oven; vi) The bag from Step v was filled with the LiPF₆ containing organic carbonate based electrolyte; vii) The bag from Step vi was sealed; viii) Rest for 16 hours; ix) The cell was charged to 4.2V at C/50 rate for 8 hours and then to 4.2V at 0.5C rate for 2 hours, then rest for 20 minutes, then discharged to 2.8V at 0.5C rate. Under vacuum, the cell was punctured to release any gases and then resealed. The cell made here was used for grading and other tests such as discharging capability test at 50°C, impact test, cycle life test and so on.

[0244] FIG. 36 lists the cell impedance at 1kHz and the capacity at 1A, 3A, 6A and 10A currents and the ratio of the capacity at 3A, 6A, 10A over that at 1A. FIG. 40 shows the cell temperature profiles during the impact test. FIG. 41 summarizes the cell maximum temperature in the impact test.

[0245] In the descriptions above and in the claims, phrases such as "at least one of" or "one or more of" may occur followed by a conjunctive list of elements or features. The term "and/or" may also occur in a list of two or more elements or features. Unless otherwise implicitly or explicitly contradicted by the context in which it used, such a phrase is intended to mean any of the listed elements or features individually or any of the recited elements or features in combination with any of the other recited elements or features. For example, the phrases "at least one of A and B;" "one or more of A and B;" and "A and/or B" are each intended to mean "A alone, B alone, or A and B together." A similar interpretation is also intended for lists including three or more items. For example, the phrases "at least one of A, B, and C;" "one or more of A, B, and C;" and "A, B, and/or C" are each intended to mean "A alone, B alone, C alone, A and B together, A and C together, B and C together, or A and B and C together." Use of the term "based on," above and in the claims is intended to mean, "based at least in part on," such that an unrecited feature or element is also permissible.

[0246] The subject matter described herein can be embodied in systems, apparatus, methods, and/or articles depending on the desired configuration. The implementations set forth in the foregoing description do not represent all implementations consistent with the

subject matter described herein. Instead, they are merely some examples consistent with aspects related to the described subject matter. Although a few variations have been described in detail above, other modifications or additions are possible. In particular, further features and/or variations can be provided in addition to those set forth herein. For example, the implementations described above can be directed to various combinations and subcombinations of the disclosed features and/or combinations and subcombinations of several further features disclosed above. In addition, the logic flows depicted in the accompanying figures and/or described herein do not necessarily require the particular order shown, or sequential order, to achieve desirable results. Other implementations may be within the scope of the following claims.

CLAIMS:

1. An improved high energy density rechargeable battery, comprising:
a first electrode;
a first current collector for transferring electrons;
5 a current interrupter layered by lamination between the first electrode and the first current collector when the current interrupter is in the engaged configuration, wherein the current interrupter is configured to delaminate from the first current collector to form a nonconductive gap that electrically decouples the first electrode and the first current collector when the current interrupter is in an unengaged configuration, wherein the current interrupter
10 comprises a heat sensitive material configured to cause, upon activation of at least a temperature trigger, a formation of a nonconductive gap between the first electrode and the first current collector, wherein the forming of the nonconductive gap electrically decouples the first electrode from the first current collector and diverts current flow from the first current collector, wherein the heat sensitive material is configured to transition the current interrupter
15 from the engaged configuration to the unengaged configuration upon activation of at least the temperature trigger, wherein the first electrode and the first current collector are electrically coupled when the current interrupter is in the engaged configuration, and wherein the nonconductive gap is formed between the first electrode and the first current collector when the current interrupter is in the unengaged configuration;
20 a second electrode having an opposite polarity of the first electrode; and
a separator interposed between the first electrode and the second electrode.
2. The battery of claim 1, further comprising a current limiter.
3. The battery of any one of claims 1-2, further comprising a second current collector.
- 25 4. The battery of claim 3, wherein the current limiter is interposed between the second electrode and the second current collector.

5. The battery of any one of claims 2-4, wherein the current limiter is interposed between the first electrode and the first current collector.

6. The battery of anyone of claims 1-5, wherein the current limiter and the current interrupter are simultaneously incorporated into a single protective layer interposed by lamination between the first electrode and the first current collector.

7. The battery of any one of claims 2-6, wherein a resistivity of the current limiter is greater than the internal resistivity of the first electrode at temperatures above a temperature range for standard operation.

8. The battery of any one of claims 2-6, wherein the resistivity of the current limiter does not transition at temperatures within the temperature range for standard operation.

9. The battery of any one of claims 2-6, wherein the resistivity of the current limiter is less than the internal resistivity of the first electrode at temperatures within a temperature range for standard operation.

10. The battery of any one of claims 1-9, wherein the temperature trigger is activated when temperature exceeds a temperature range for standard operation.

11. The battery of any one of claims 1-10, wherein the heat sensitive material is further configured to cause the formation of the nonconductive gap upon activation of a voltage trigger, and wherein the voltage trigger is activated when voltage exceeds a voltage range for standard operation.

12. The battery of any one of claims 1-11, wherein the first electrode and the first current collector are electrically coupled via a laminated connection provided by the current interrupter when the current interrupter is in the engaged configuration, and wherein the forming of the nonconductive gap delaminates the laminated connection between the first electrode and the first current collector.

13. The battery of any one of claims 1-12, wherein the heat sensitive material forms the nonconductive gap by at least generating, upon activation of at least the temperature trigger, a gas.

5 14. The battery of any one of claims 1-13, wherein the heat sensitive material forms the nonconductive gap by at least generating, upon activation of at least the temperature trigger, a liquid.

15. The battery of any of claims 14, wherein the liquid generates a gas through vaporization.

10 16. The battery of any one of claims 14-15, wherein the liquid generates a gas by reacting with the first electrode, the first current collector, the separator, and/or an electrolyte comprising the battery.

17. A method, comprising:

forming a nonconductive gap between an electrode within a battery and a current collector, wherein the forming of the nonconductive gap is caused by a heat sensitive material in response to an activation of least a temperature trigger, wherein the heat sensitive material comprises a current interrupter layered by lamination between the electrode and current collector when the current interrupter is in an engaged configuration, wherein the current interrupter is configured to delaminate from the current collector to form the nonconductive gap that electrically decouples the electrode and the current collector when the current interrupter is in an unengaged configuration, wherein the forming of the nonconductive gap electrically decouples the electrode from the current collector and diverts current flow from the current collector, wherein the heat sensitive material is configured to transition the current interrupter from the engaged configuration to the unengaged configuration upon activation of at least the temperature trigger, wherein the electrode and the current collector are electrically coupled when the current interrupter is in the engaged configuration, and wherein the nonconductive gap is formed between the electrode and the current collector when the current interrupter is in the unengaged configuration.

15
20
25

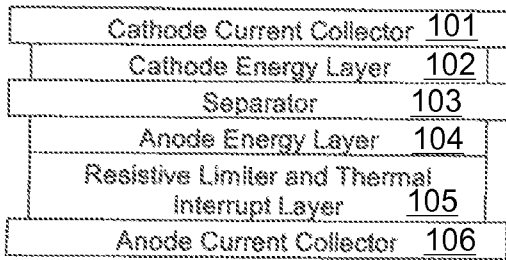

FIG. 1A

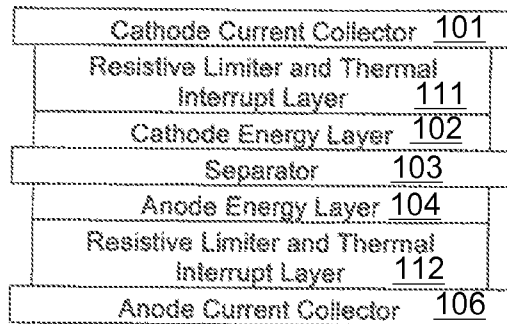

FIG. 1E

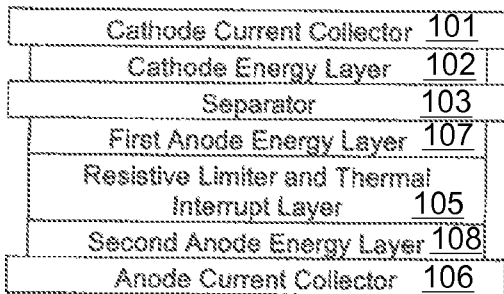

FIG. 1B

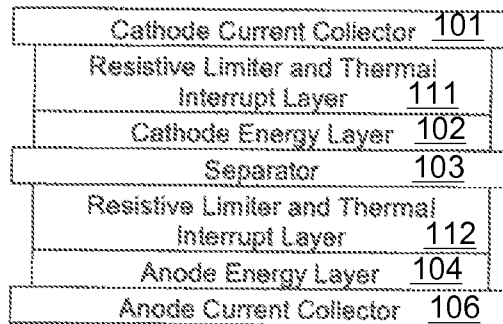

FIG. 1F

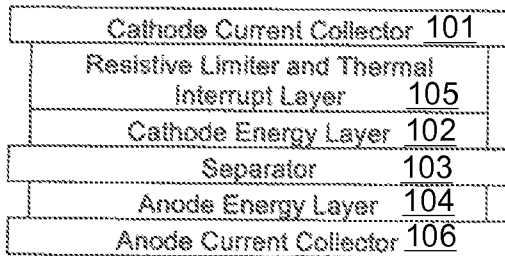

FIG. 1C

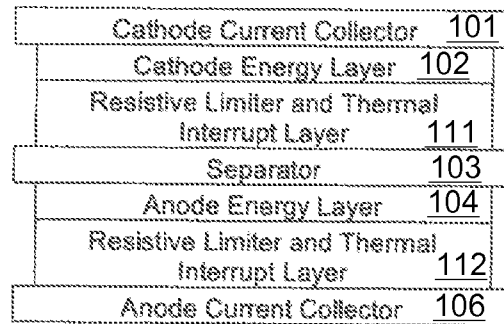

FIG. 1G

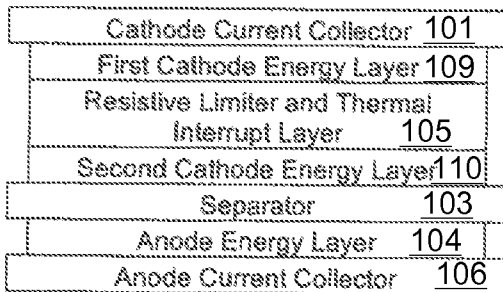

FIG. 1D

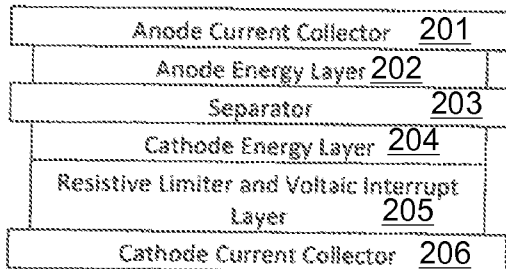

FIG. 2A

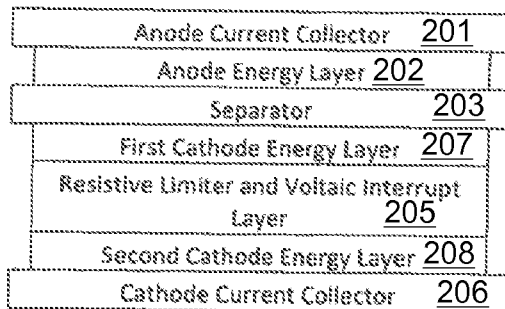

FIG. 2B

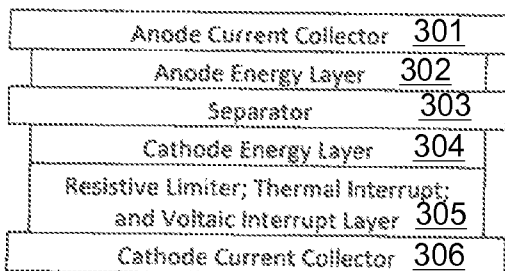

FIG. 3A

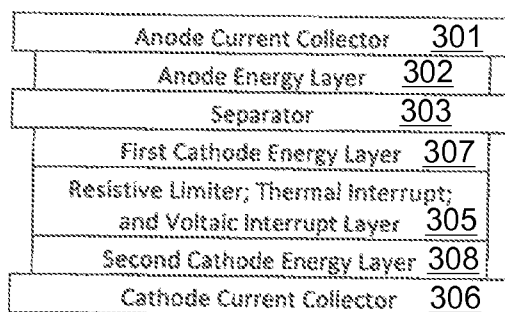
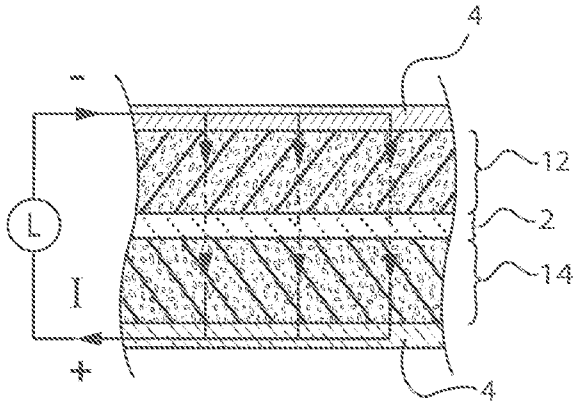
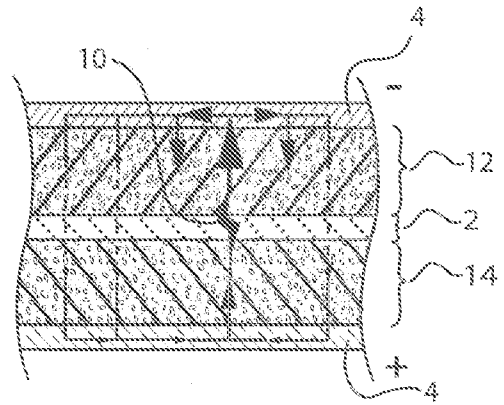

FIG. 3B



Prior Art - Unshorted

FIG. 4A



Prior Art - Shorted

FIG. 4B

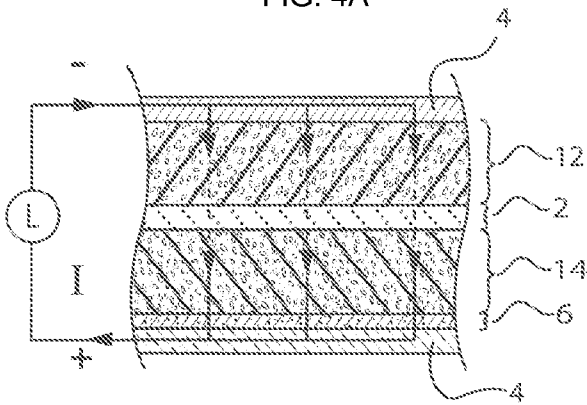

Unshorted

FIG. 4C

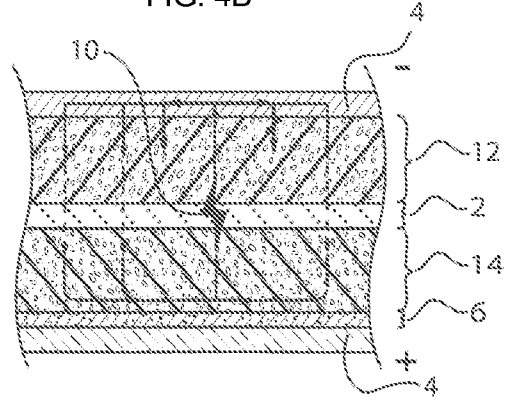

Shorted

FIG. 4D

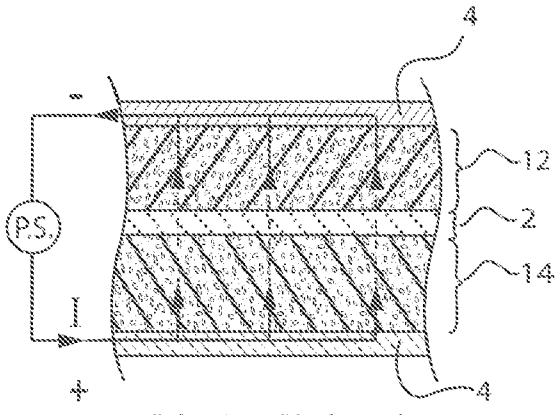

Prior Art - Unshorted

FIG. 5A

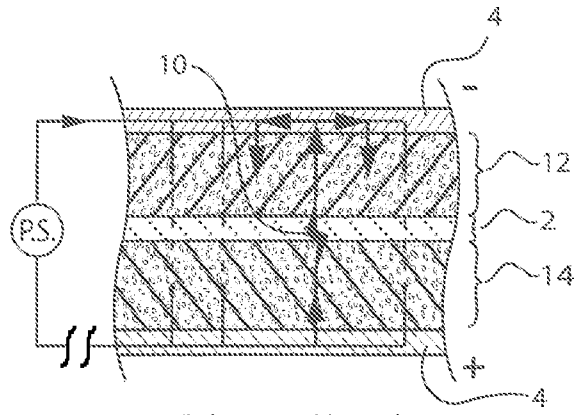

Prior Art - Shorted

FIG. 5B

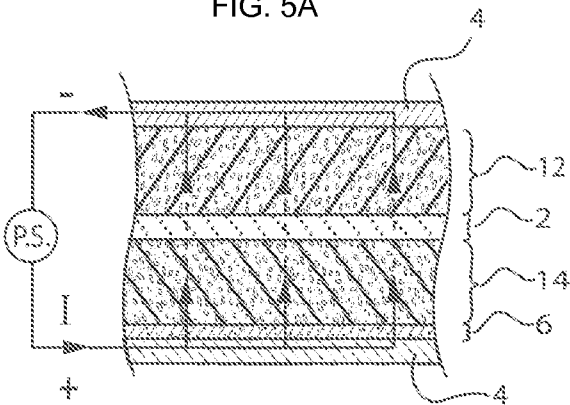

Unshorted

FIG. 5C

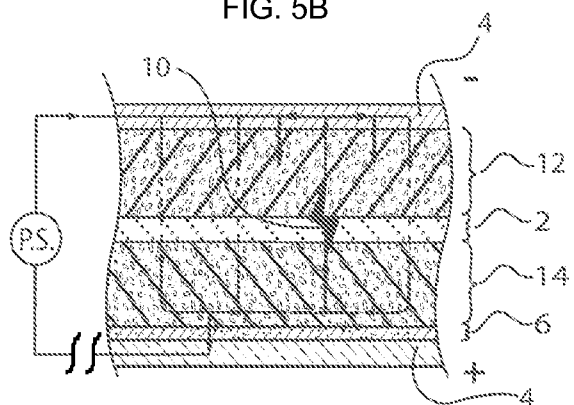

Shorted

FIG. 5D

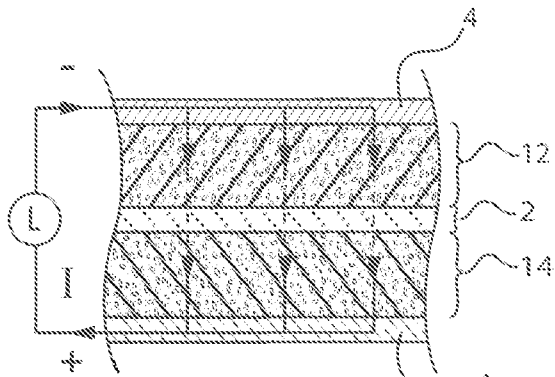

Prior Art - Unshorted

FIG. 6A

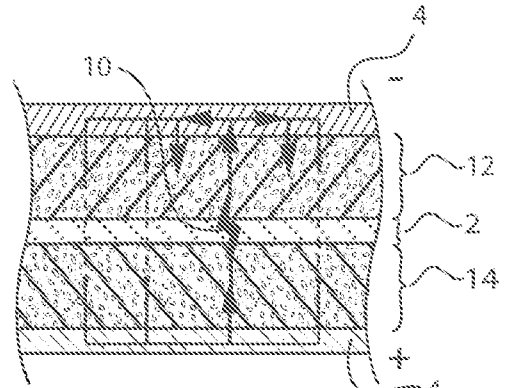

Prior Art - Shorted

FIG. 6B

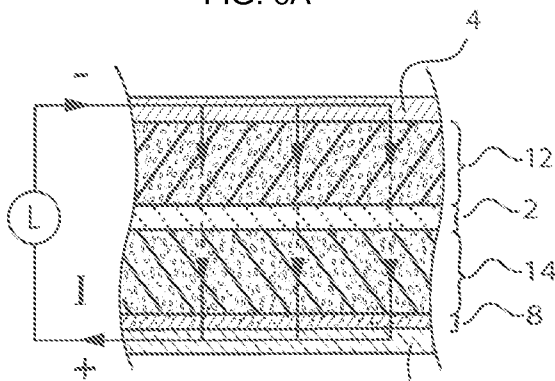

Unshorted

FIG. 6C

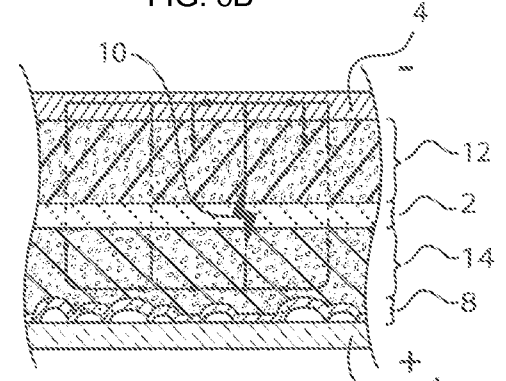

Shorted

FIG. 6D

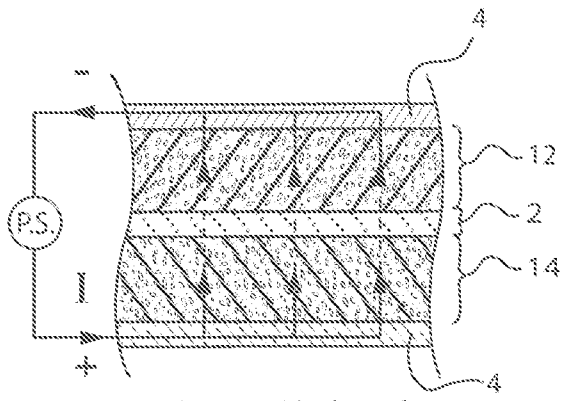

Prior Art - Unshorted

FIG. 7A

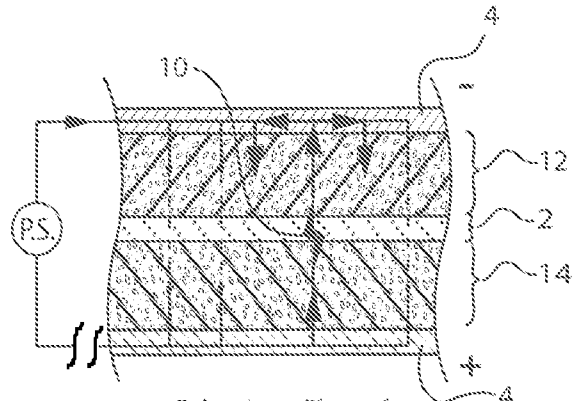

Prior Art - Shorted

FIG. 7B

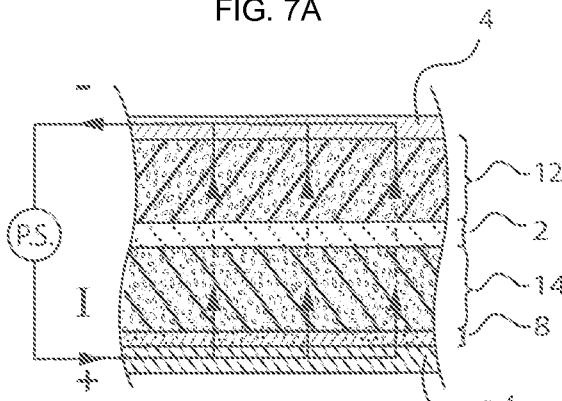

Unshorted

FIG. 7C

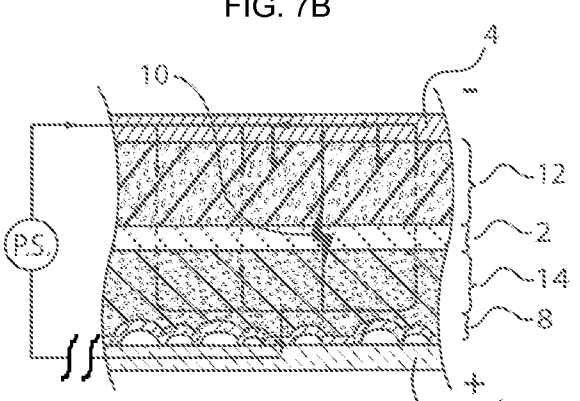

Shorted

FIG. 7D

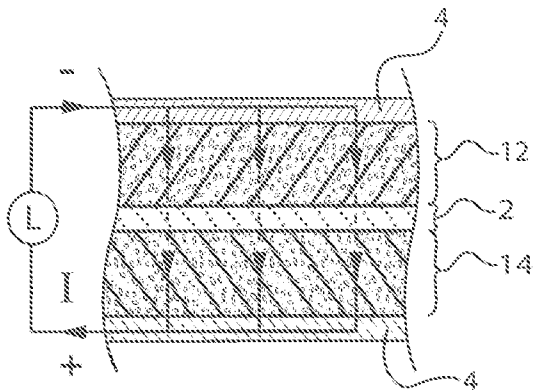

Prior Art - Unshorted

FIG. 8A

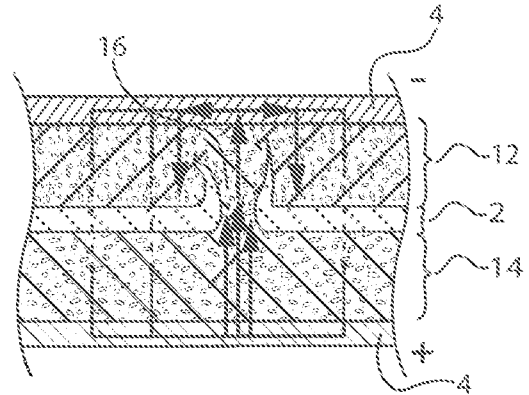

Prior Art - Shorted

FIG. 8B

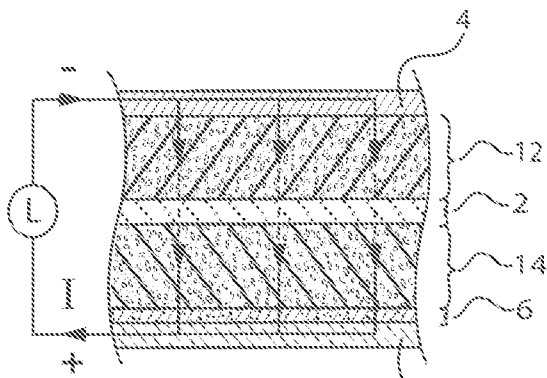

Unshorted

FIG. 8C

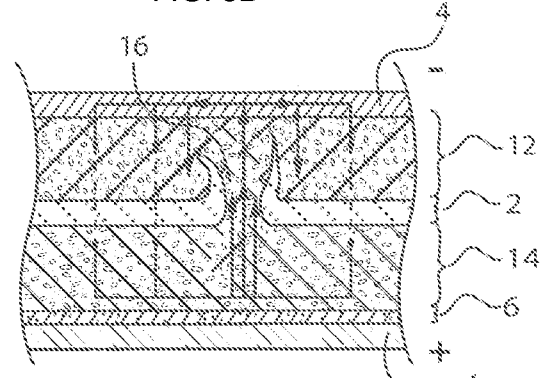

Shorted

FIG. 8D

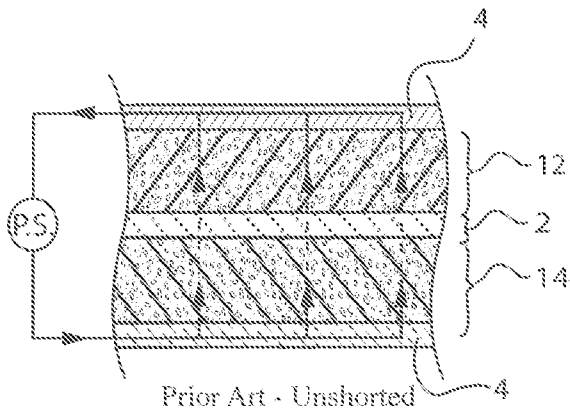

FIG. 9A

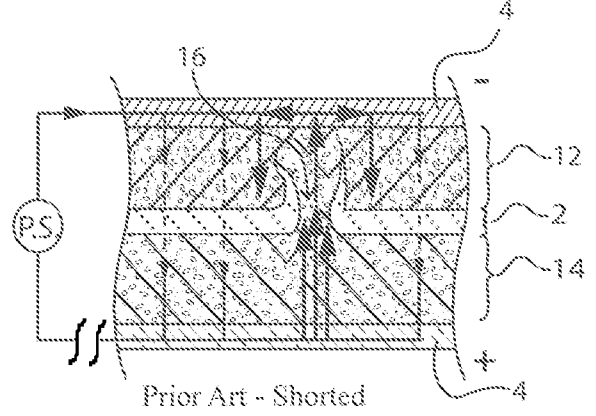

FIG. 9B

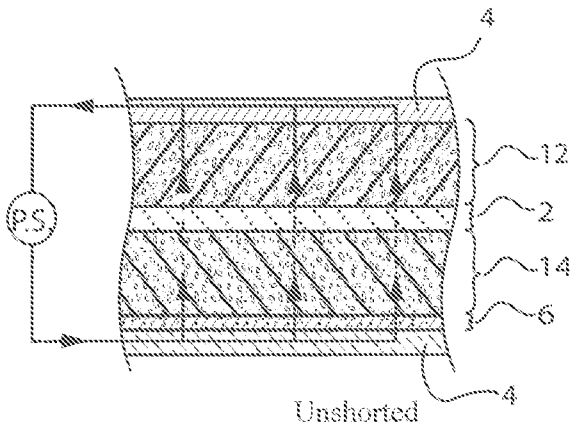

FIG. 9C

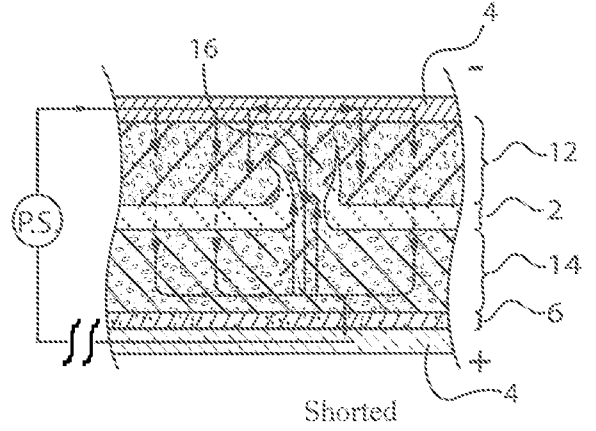
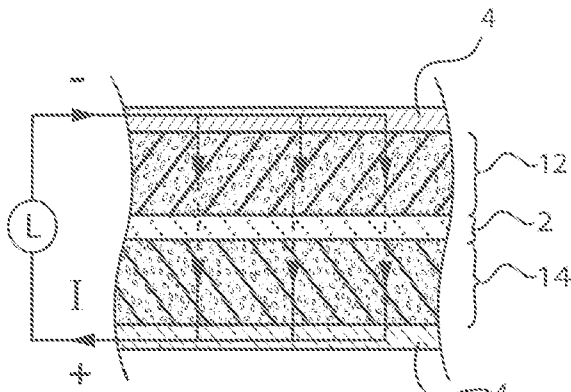
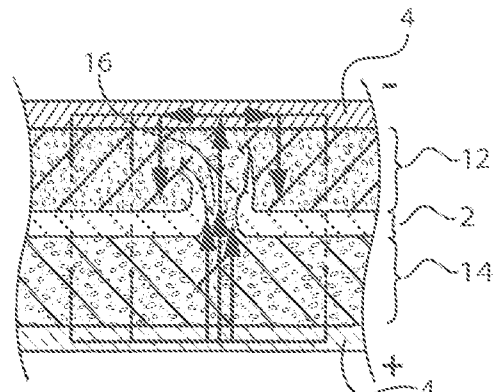

FIG. 9D



Prior Art - Unshorted

FIG. 10A



Prior Art - Shorted

FIG. 10B

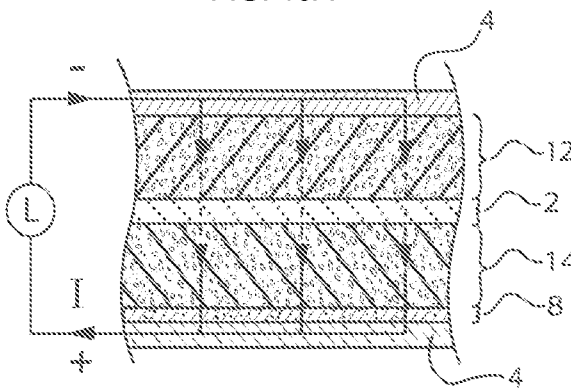

Unshorted

FIG. 10C

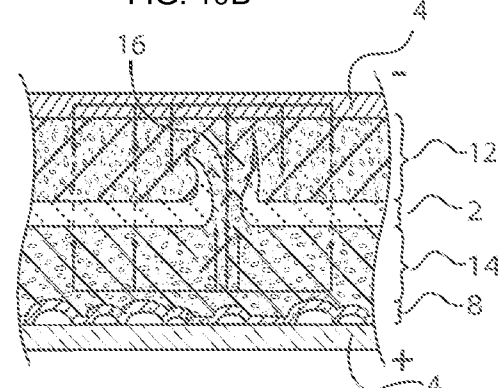

Shorted

FIG. 10D

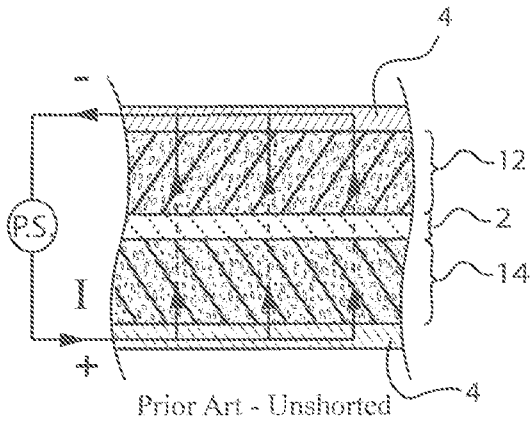

FIG. 11A

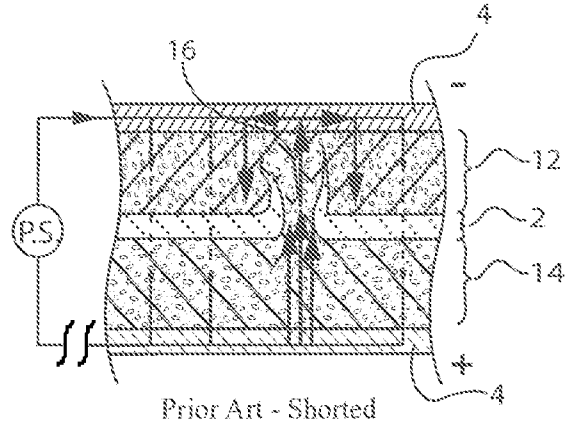

FIG. 11B

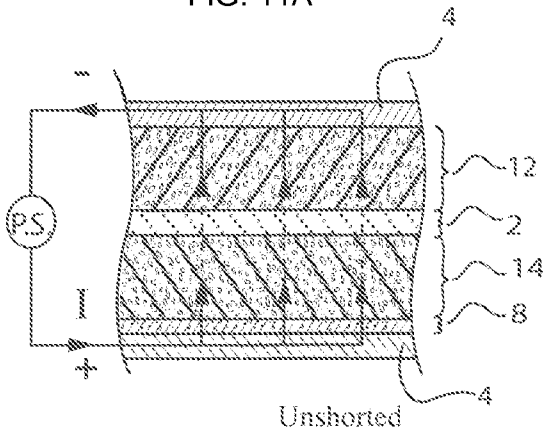

FIG. 11C

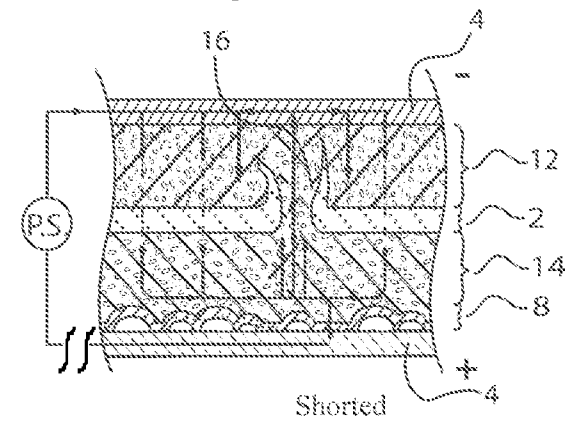

FIG. 11D

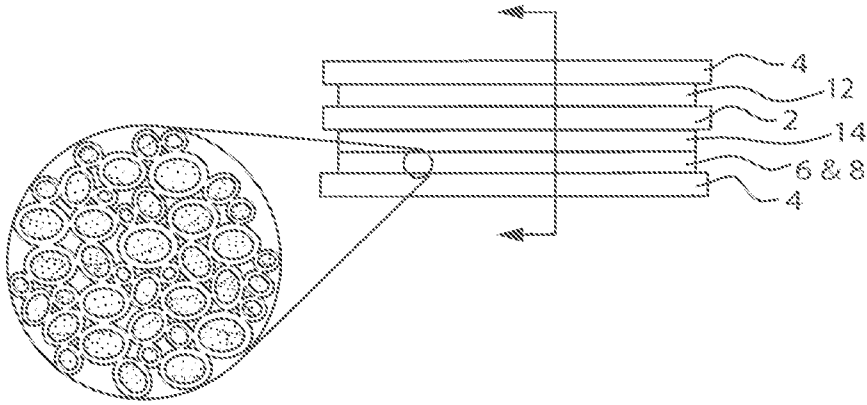

FIG. 12A

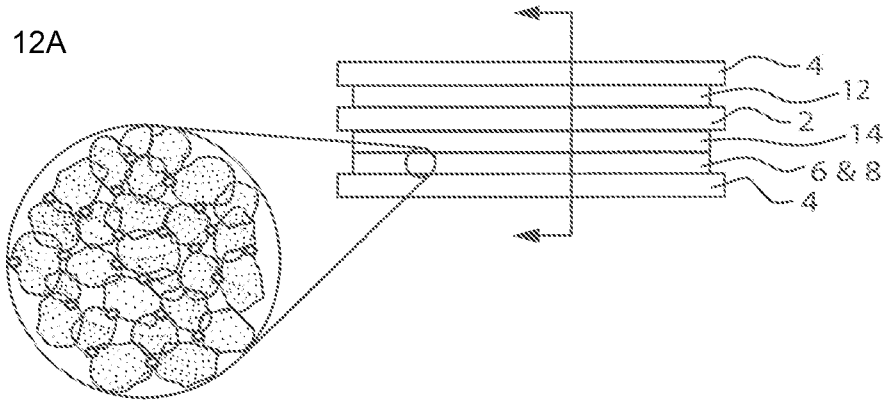

FIG. 12B

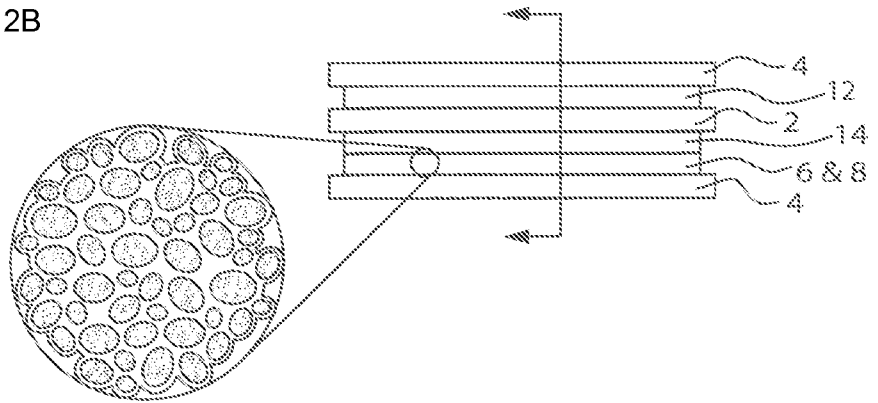

FIG. 12C

12/29

Cell #	Positive Electrode	Negative Electrode	Comments
1	POS1A: $\text{LiNi}_{0.5}\text{Mn}_{0.3}\text{Co}_{0.2}\text{O}_2$: 93.4%; Carbon Black: 3%; PVDF: 3.6%; Loading: 15.55 mg/cm ² ; Thickness: 117 μm .	NEG1A: SLP 30: 18.272%; MCMB : 75.728%; Carbon Black: 2%; CMC: 1.5%; SBR: 2.5%; Loading: 9.14 mg/cm ² ; Thickness: 117 μm .	Baseline; no protection layer
2	POS2A: $\text{Li}_{1-x}\text{Ni}_{0.33}\text{Co}_{0.33}\text{Mn}_{0.33}\text{O}_2$: 95.3% Carbon black: 1.5%; PVDF: 3%; Dispersing agent: 0.2%; Loading: 15.92 mg/cm ² ; Thickness: 123 μm .	NEG2A: SLP 30: 18.872%; MCMB: 75.728%; Carbon Black: 2%; CMC: 1.3%; SBR: 2.1%; Loading: 8.54 mg/cm ² ; Thickness: 118 μm .	Baseline; no protection layer; resistance measurement for positive POS2A at 3.6V vs graphite
3	POS3B: 1 st layer CaCO_3 : 85.2%; Carbon black: 0.8%; TF-4000: 2%; PVDF: 12%; 1 st layer Loading: 1 mg/cm ² ; 1 st layer Thickness: ~10 μm . POS3A: 2 nd layer $\text{LiNi}_{0.33}\text{Mn}_{0.33}\text{Co}_{0.33}\text{O}_2$: 93.4%; Carbon Black: 3%; PVDF: 3.6%. Total electrode (two layers): Loading: 19.44 mg/cm ² ; Thickness: ~148 μm .	NEG3A: SLP 30: 18.872%; MCMB: 75.728%; Carbon Black: 2%; CMC: 1.3%; SBR: 2.1%; Loading: 11.8 mg/cm ² ; Thickness: 159 μm .	Gas generating layer coated on positive electrode.
4	POS4B: 1 st layer Al_2O_3 : 42.6%; CaCO_3 : 42.6%; Carbon Black: 0.8%; TF-4000: 2%; PVDF: 12%; 1 st layer Loading: 1 mg/cm ² ; 1 st layer Thickness: 10 μm . POS4A: 2 nd layer $\text{LiNi}_{0.5}\text{Mn}_{0.3}\text{Co}_{0.2}\text{O}_2$: 93.4%; Carbon Black: 3%; PVDF: 3.6%. Total electrode (two layers): Loading: 19.4 mg/cm ² ; Thickness: ~153 μm .	NEG4A: SLP 30: 18.872%; MCMB: 75.728%; Carbon Black: 2%; CMC: 1.3%; SBR: 2.1%; Loading: 11.8 mg/cm ² ; Thickness: 159 μm .	Resistance and gas generating layer coated on positive electrode.

FIG. 13A

5	<p>POS5B: 1st layer Al_2O_3: 42.6%; $\text{Na}_2\text{O}_7\text{Si}_3$: 42.6%; Carbon Black: 0.8%; TF-4000: 2%; PVDF: 12%. 1st layer Loading: 0.7 mg/cm²; 1st layer Thickness: 10 μm.</p> <p>POS5A: 2nd layer $\text{LiNi}_{0.33}\text{Mn}_{0.33}\text{Co}_{0.33}\text{O}_2$: 95.%; Carbon Black: 1.5%; PVDF: 3.5%. Total electrode (two layers): Loading: 19.5 mg/cm²; Thickness: ~150 μm.</p>	<p>NEG5A: SLP 30: 18.872%; MCMB : 75.728%; Carbon Black: 2%; CMC: 1.3%; SBR: 2.1%; Loading: 11.8 mg/cm²; Thickness: 159 μm.</p>	<p>Resistance and gas generating layer coated on positive electrode. ($\text{Na}_2\text{O}_7\text{Si}_3$ will absorb the water during the processing in the air and decompose into quartz, sodium disilicate, and liquid)</p>
6	<p>POS6B: 1st layer CaCO_3: 49.8%; Carbon Black: 3.7%; PVDF: 46.5%; 1st layer Loading: 1 mg/cm²; 1st layer Thickness: ~10 μm.</p> <p>POS6A: 2nd layer $\text{LiNi}_{0.33}\text{Mn}_{0.33}\text{Co}_{0.33}\text{O}_2$: 93%; Carbon Black: 3%; PVDF: 4%; Total electrode (two layers): Loading: 22 mg/cm²; Thickness: ~167 μm.</p>	<p>NEG6A: MCMB: 94%; Carbon Black: 2%; CMC: 1.5%; SBR: 2.5%; Loading: 12 mg/cm²; Thickness: 170 μm.</p>	<p>Gas generating layer coated on positive electrode.</p>
7	<p>POS071A: 1st layer $\text{LiNi}_{0.33}\text{Mn}_{0.33}\text{Co}_{0.33}\text{O}_2$: 89.96% CaCO_3: 4.74% Carbon Black: 1.2%; TF- 4000: 0.6% PVDF: 3.5% 1st layer Loading: 4 mg/cm² 1st layer Thickness: ~0.04 mm</p> <p>POS071B: 2nd layer $\text{LiNi}_{0.82}\text{Al}_{0.03}\text{Co}_{0.15}\text{O}_2$: 92.8% Carbon Black: 3% PVDF A: 3.6% TF-4000: 0.6% Total electrode (two layers): Loading: 16 mg/cm² Thickness: ~ 0.105 μm.</p>	<p>NEG015B: MCMB: 94.5% Carbon Black: 1.5% CMC: 1.5% SBR: 2.5% Loading: ~11.8 mg/cm² Thickness: ~0.155 mm.</p>	<p>The first layer , the gas generator contains the gas generator CaCO_3 and active $\text{LiNi}_{0.33}\text{Mn}_{0.33}\text{Co}_{0.33}\text{O}_2$, which will maximize the battery cell capacity</p>

FIG. 13B

Electrode ID	Materials	(%)	(g)	Comments
POS7B	Carbopol®-934	98.2	19.64	Polymer with CO ₃ ²⁻ anion.
	Super-P®	0.8	0.16	
	LiOH	1	0.2	
POS8B	AI-50	99.2	19.84	Polymer containing carbonyl group and NH ₂ group which may decompose into CO ₂ .
	Super-P®	0.8	0.16	
POS9B	CMC-DN-800H	99.2	19.84	Polymer containing carboxylic acid groups with NH ₄ cations
	Super-P®	0.8	0.16	
POS10B	ZnCO ₃ .Zn(OH) ₂	85.2	17.04	Salt
	Super-P®	0.8	0.16	
	Torlon® 4000TF	2	0.4	
	PVDF-A	12	2.4	
POS11B	Na ₂ SO ₃	85.2	17.04	Salt
	Super-P®	0.8	0.16	
	Torlon® 4000TF	2	0.4	
	PVDF-A	12	2.4	
POS12B	CuCO ₃ . Cu(OH) ₂	85.2	17.04	Salt
	Super-P®	0.8	0.16	
	Torlon® 4000TF	2	0.4	
	PVDF-A	12	2.4	
POS13B	La ₂ (CO ₃) ₃	85.2	17.04	Salt
	Super-P®	0.8	0.16	
	Torlon® 4000TF	2	0.4	
	PVDF-A	12	2.4	
POS14B	Cu(NO ₃) ₂	85.2	17.04	Salt
	Super-P®	0.8	0.16	
	Torlon® 4000TF	12	2.4	
	PVDF-A	0.1	0.02	

FIG. 14

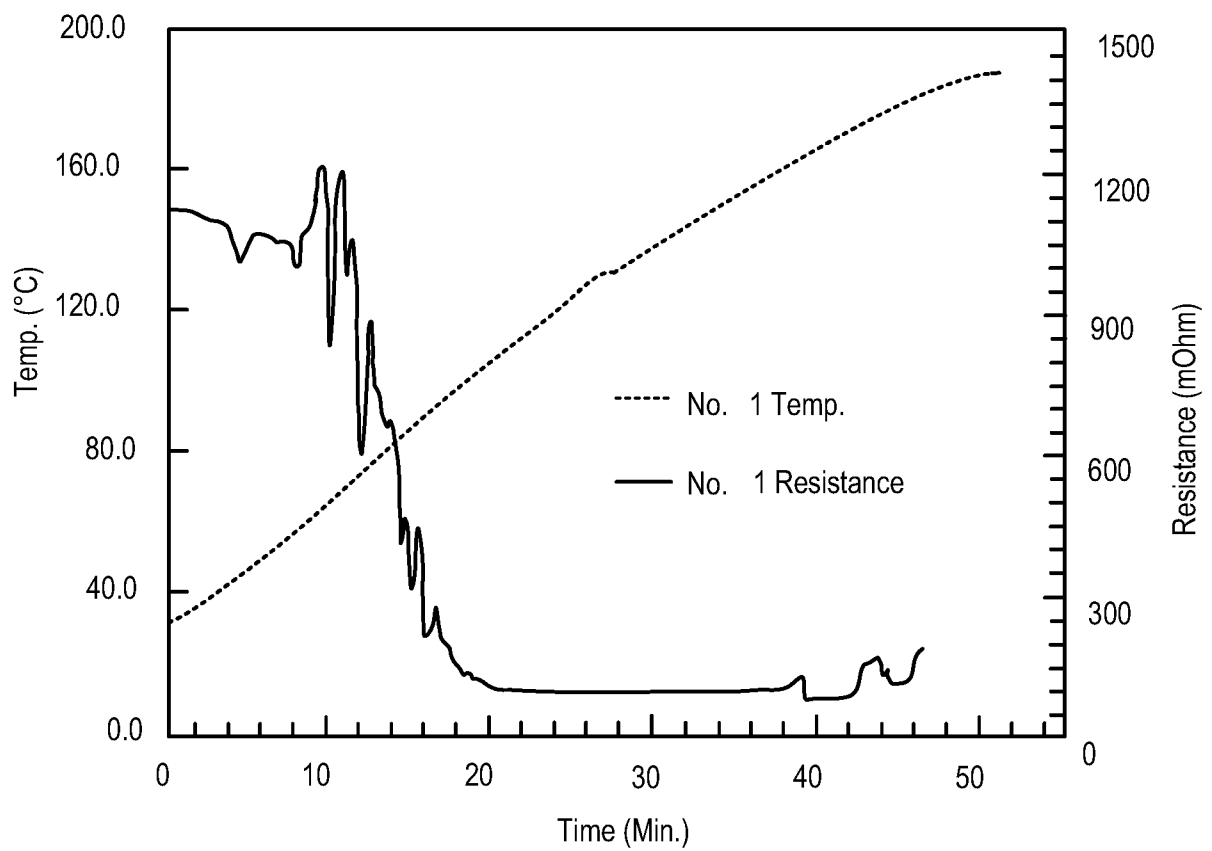

FIG. 15

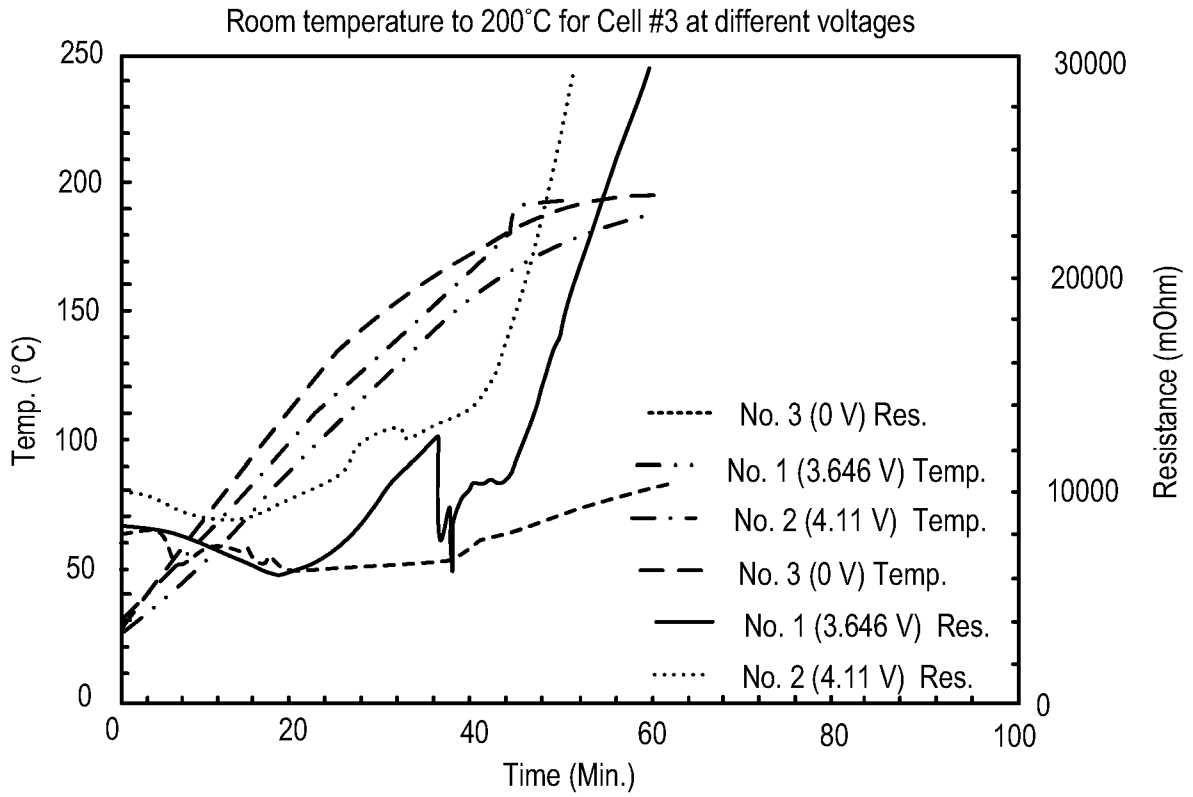

FIG. 16

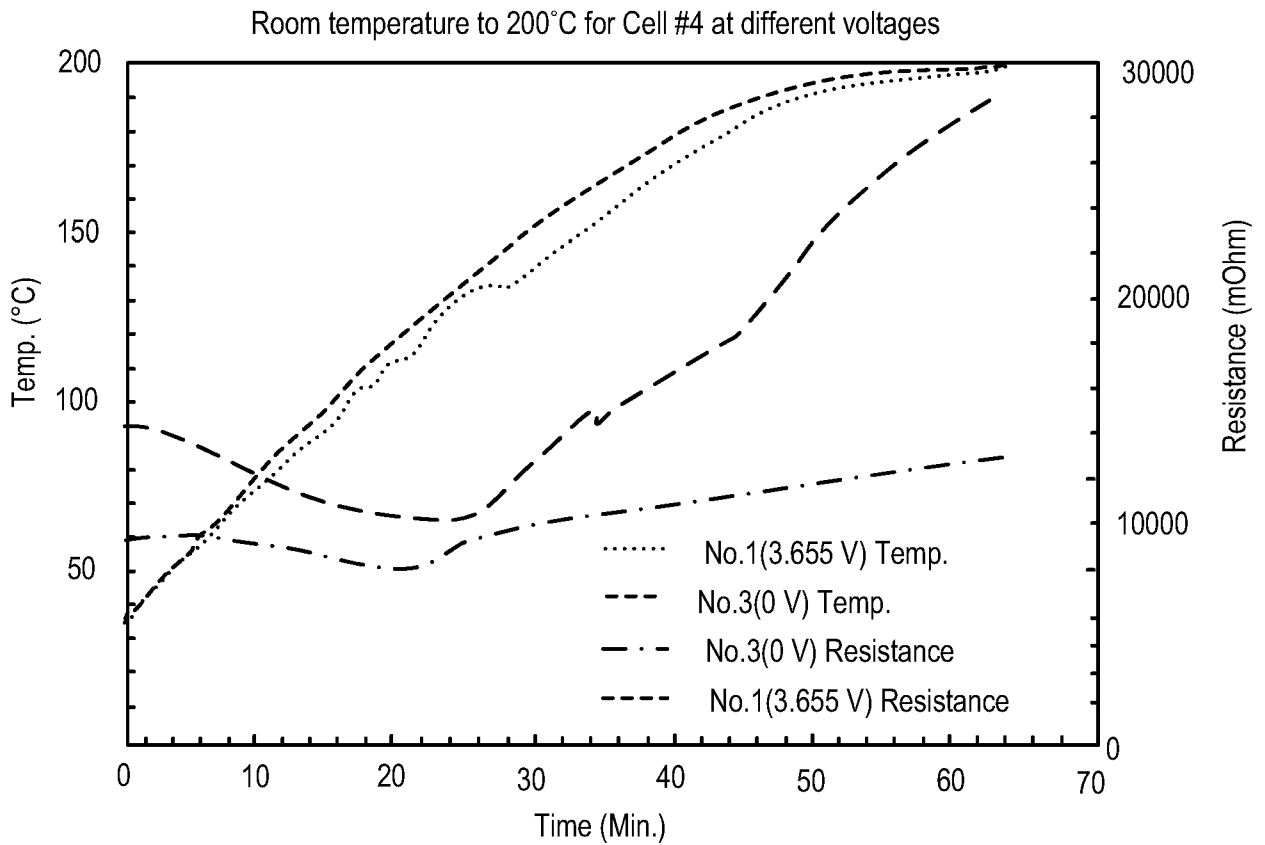

FIG. 17

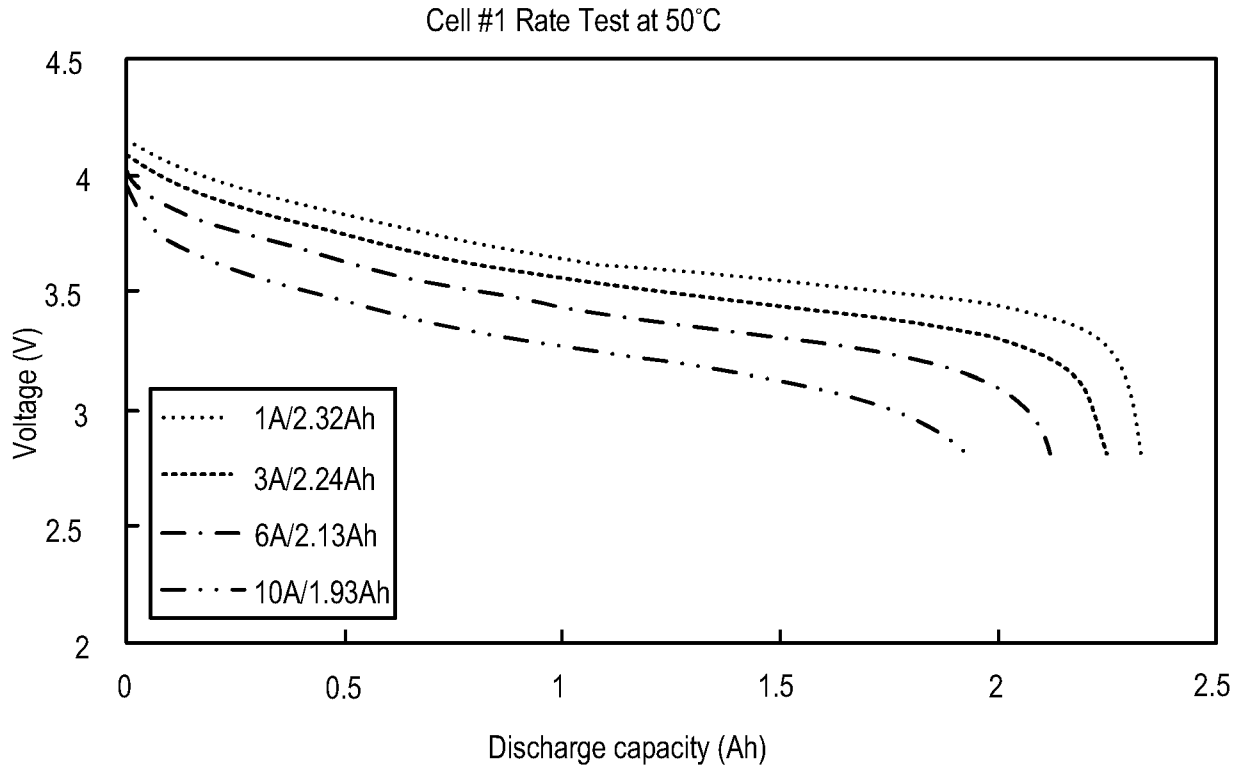

FIG. 18

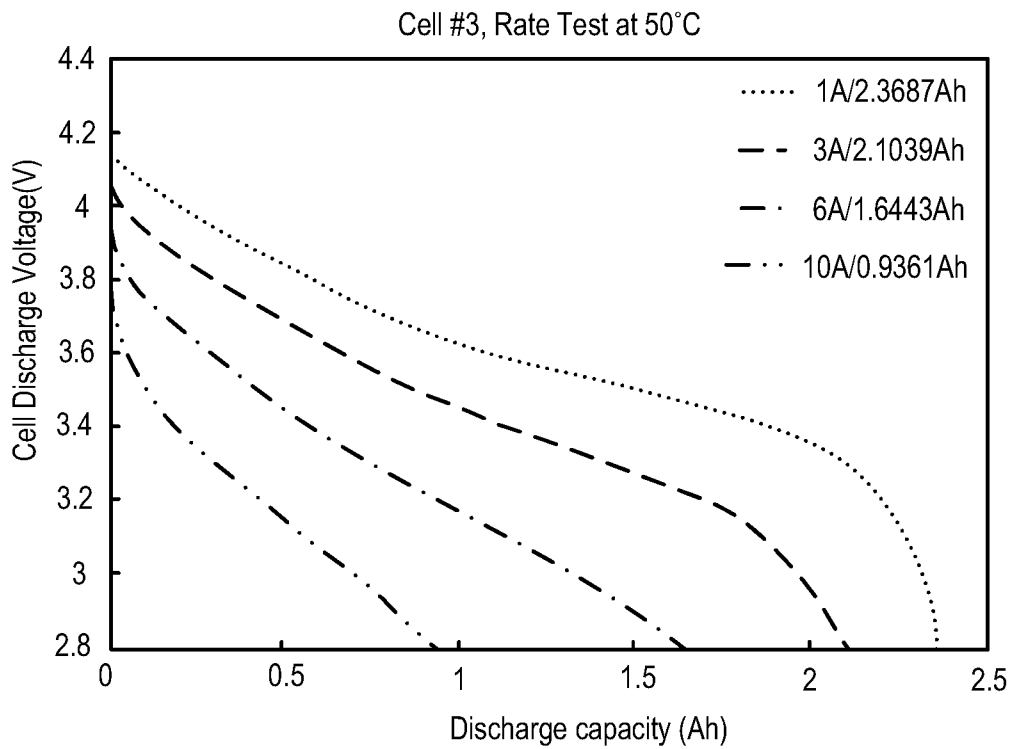

FIG. 19

Cell#	Impedance (mohm)	Cap. At 1A (Ah)	Cap. At 3A (Ah)	Cap. At 6A (Ah)	Cap. At 10A (Ah)	Ratio (Cap. At/3 A/Cap. At 1A)	Ratio (Cap. At/6 A/Cap. at 1A)	Ratio (Cap. At/10 A/Cap. At 1A)
1	14	2.32	2.24	2.13	1.93	0.97	0.95	0.91
3	51.6	2.3687	2.104	1.64	0.94	0.89	0.78	0.57
4	46.8	2.3809	2.2607	1.8414	1.0256	0.95	0.81	0.56
5	16.5	2.4168	2.3792	2.3	2.06	0.98	0.97	0.9
6	15.8	2.3383	2.2495	2.1446	1.967	0.96	0.95	0.92

FIG. 20

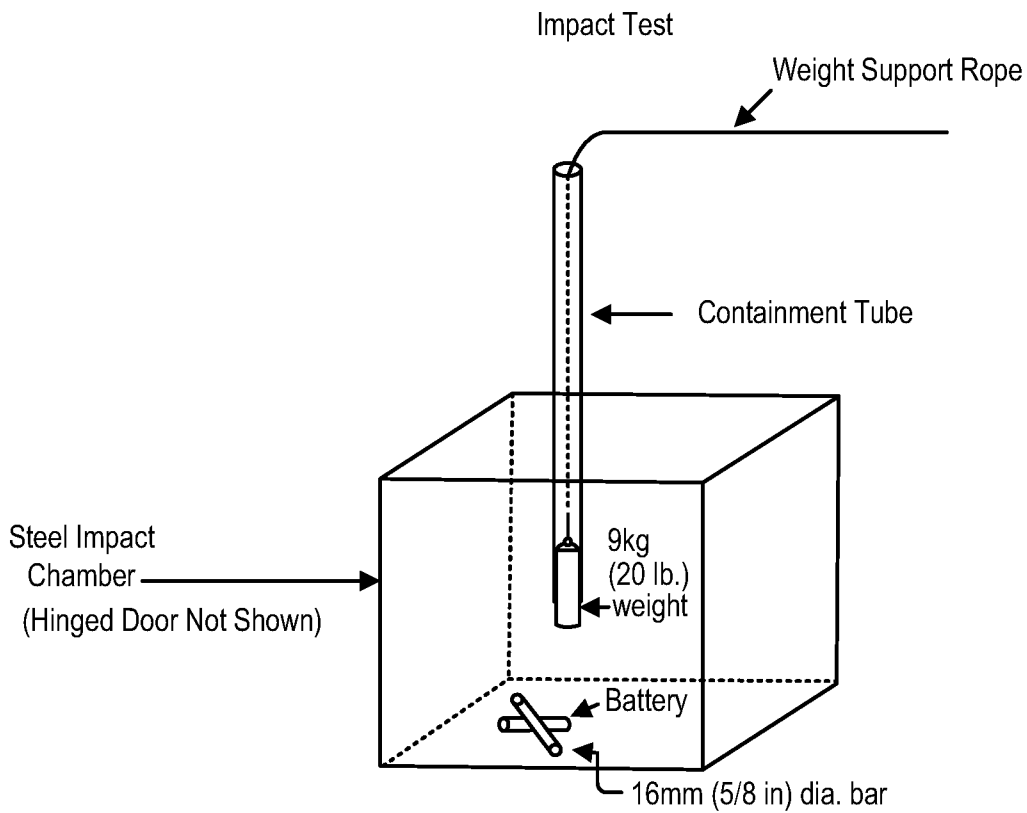

FIG. 21

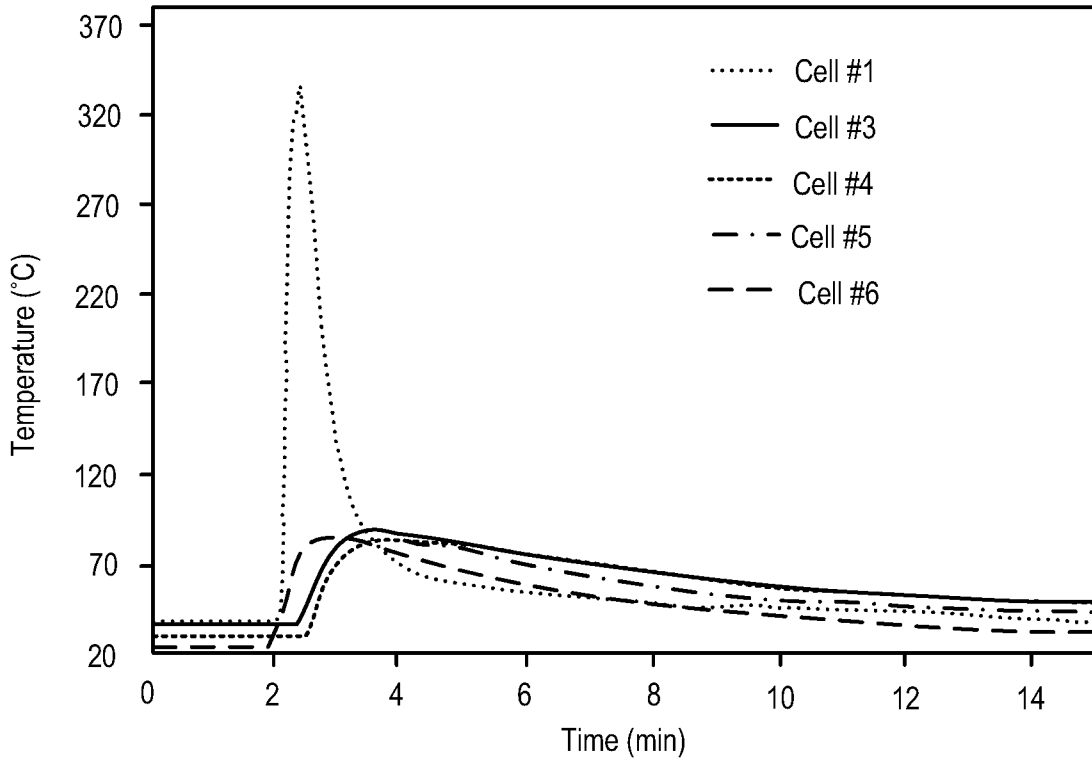

FIG. 22

Cell #	Maximum Cell Temperature (°C)	Comments
1	334	fire and explosion
3	80	pass
4	84	pass
5	90	pass
6	84	pass

FIG. 23

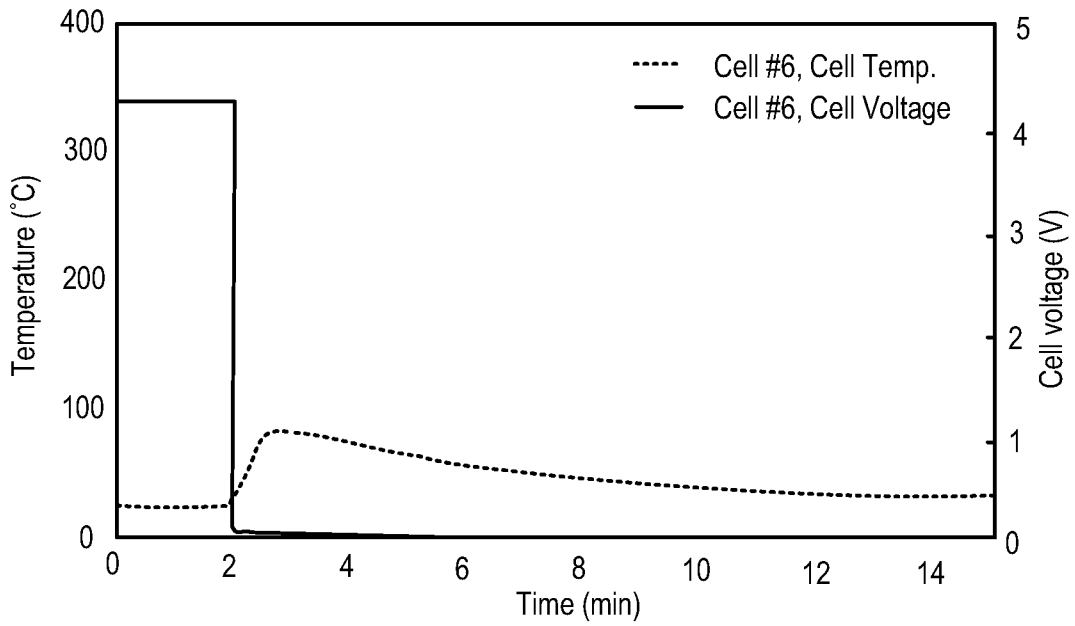

FIG. 24

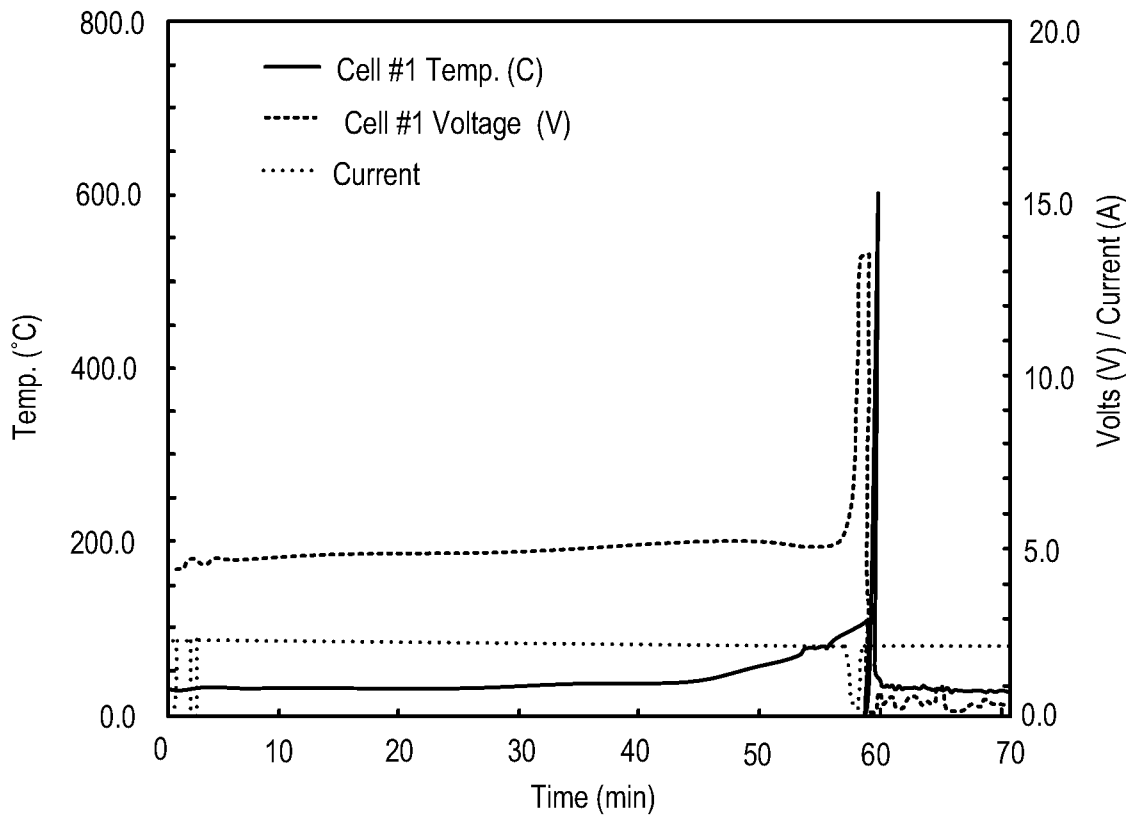
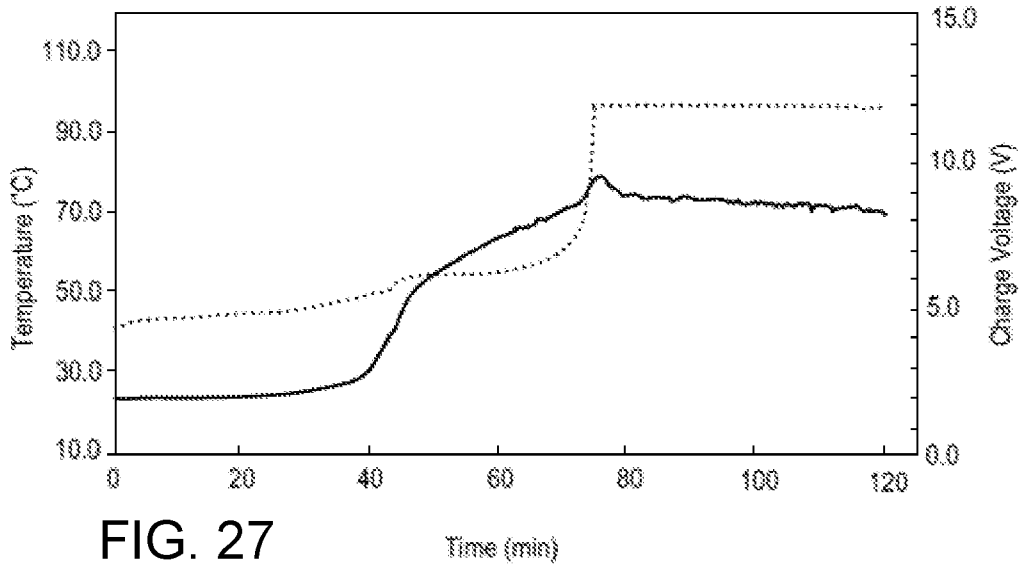
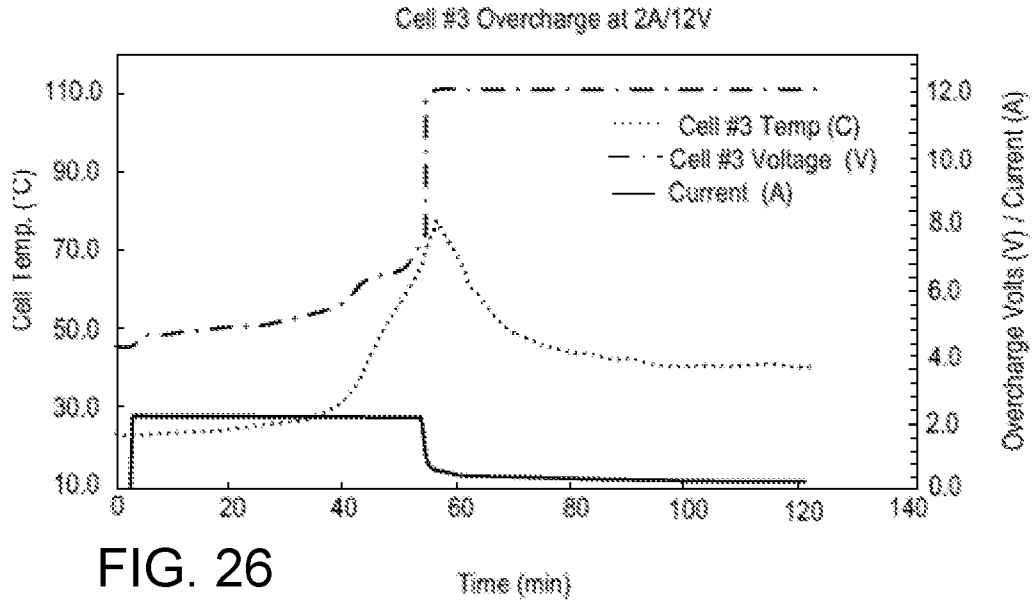

FIG. 25



Cell #	Maximum Cell Temperature/°C	Comments
1	680	fire and explosion
3	80	pass
4	80	pass
5	75	pass
6	80	pass

FIG. 28

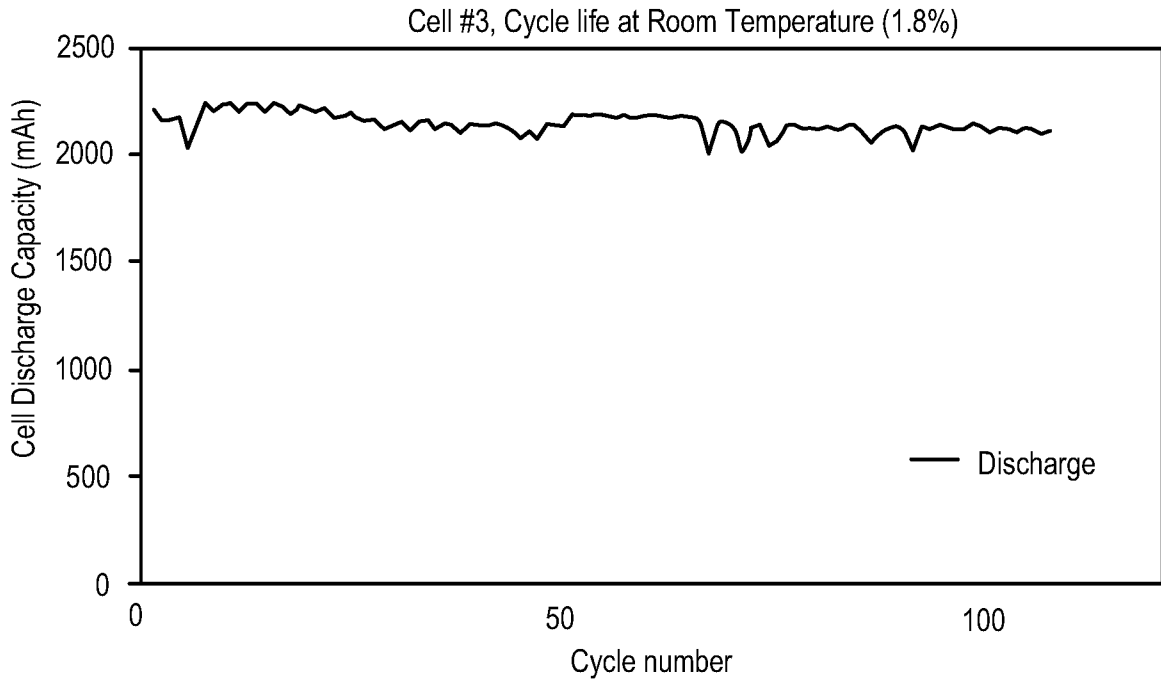

FIG. 29

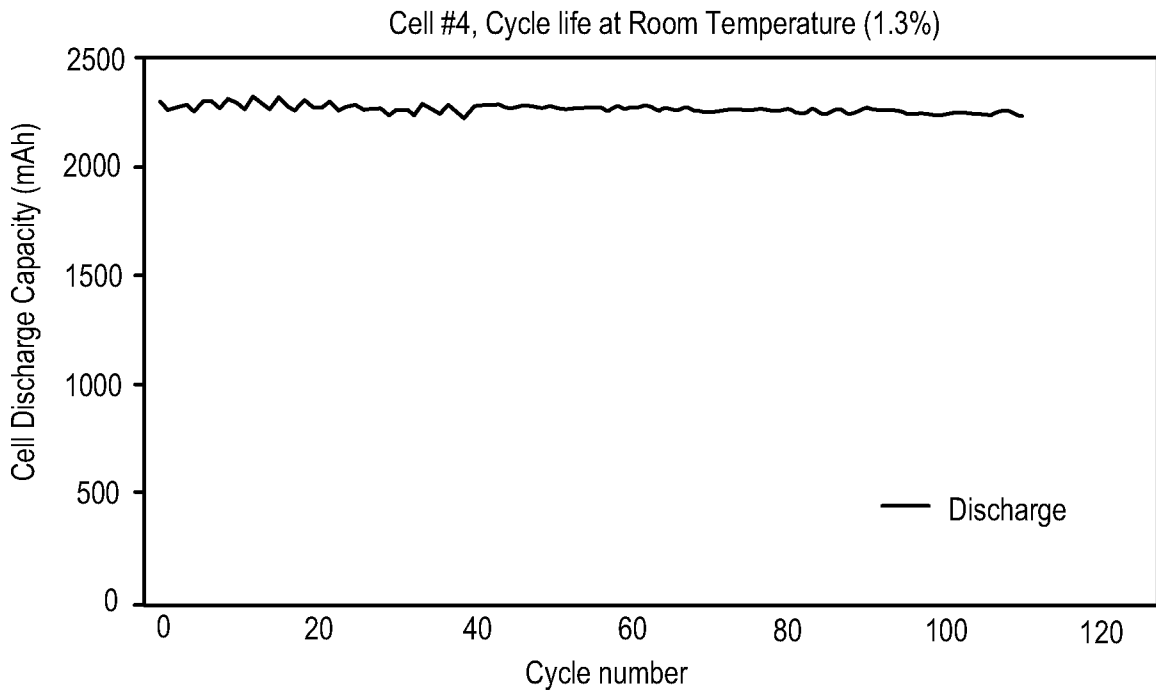

FIG. 30

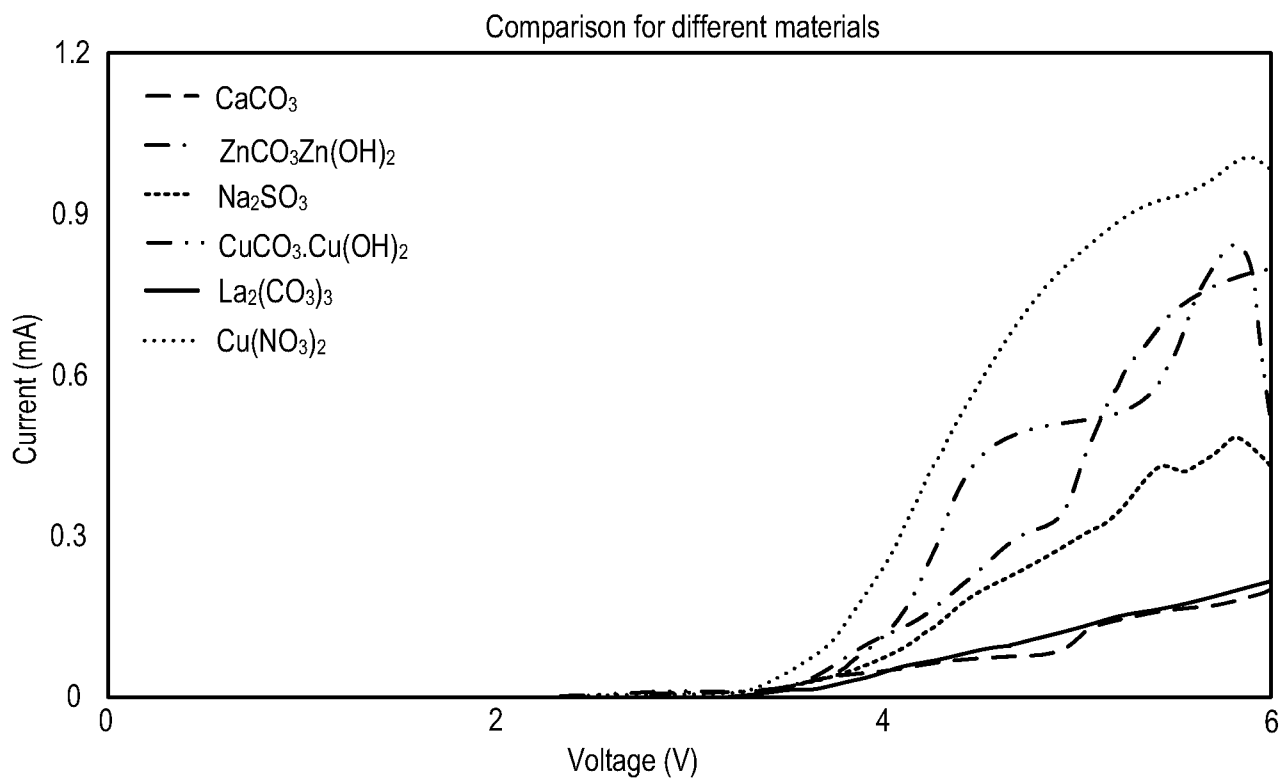

FIG. 31

Compounds	Peak current (mA)	Peak Voltage (V)
CaCO ₃	0.2	>6
La ₂ (CO ₃) ₃	0.2	>6
Na ₂ SO ₃	0.48	5.84
ZnCO ₃ Zn(OH) ₂	0.77	5.89
CuCO ₃ .Cu(OH) ₂	0.78	5.78
Cu(NO ₃) ₂	1	5.8

FIG. 32

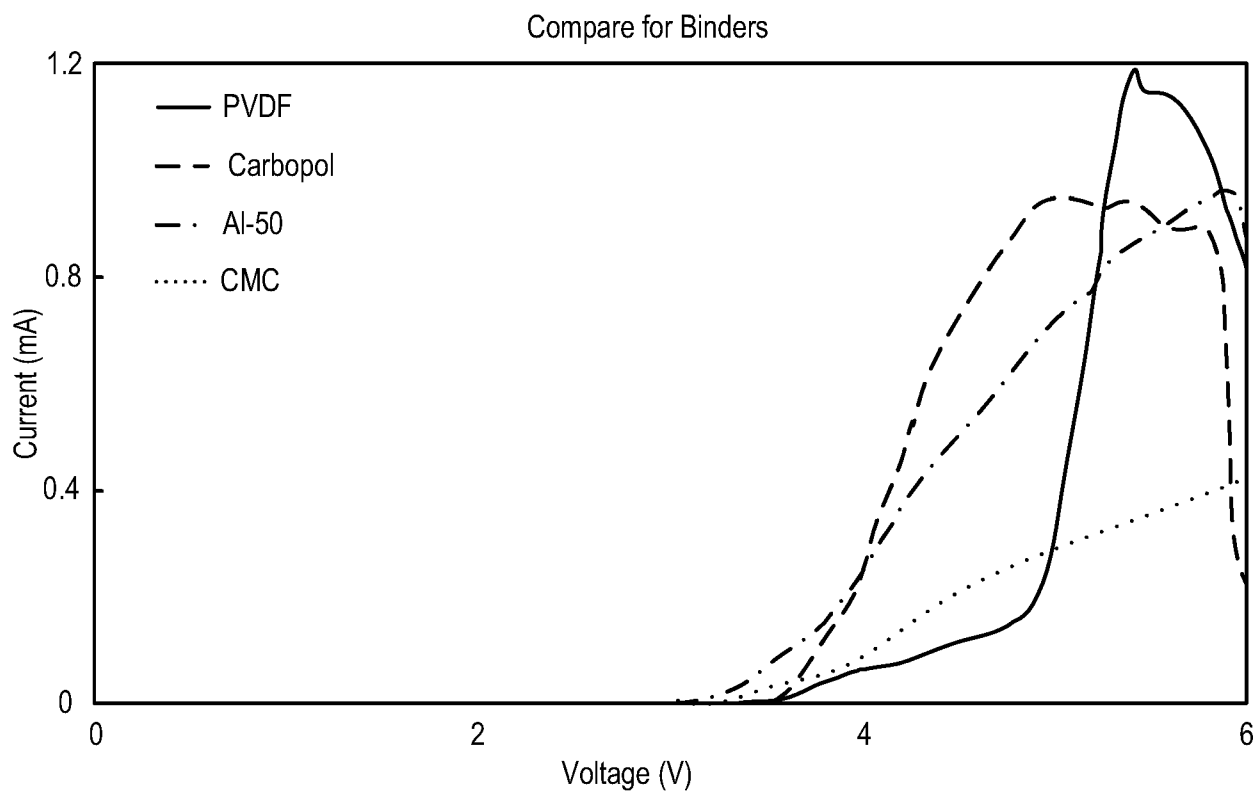

FIG. 33

Polymers	Peak current/mA	Peak Voltage/V
Carbopol	0.94	4.95
Al-50	0.96	5.88
CMC	0.4	>6
PVDF	1.178	5.38

FIG. 34

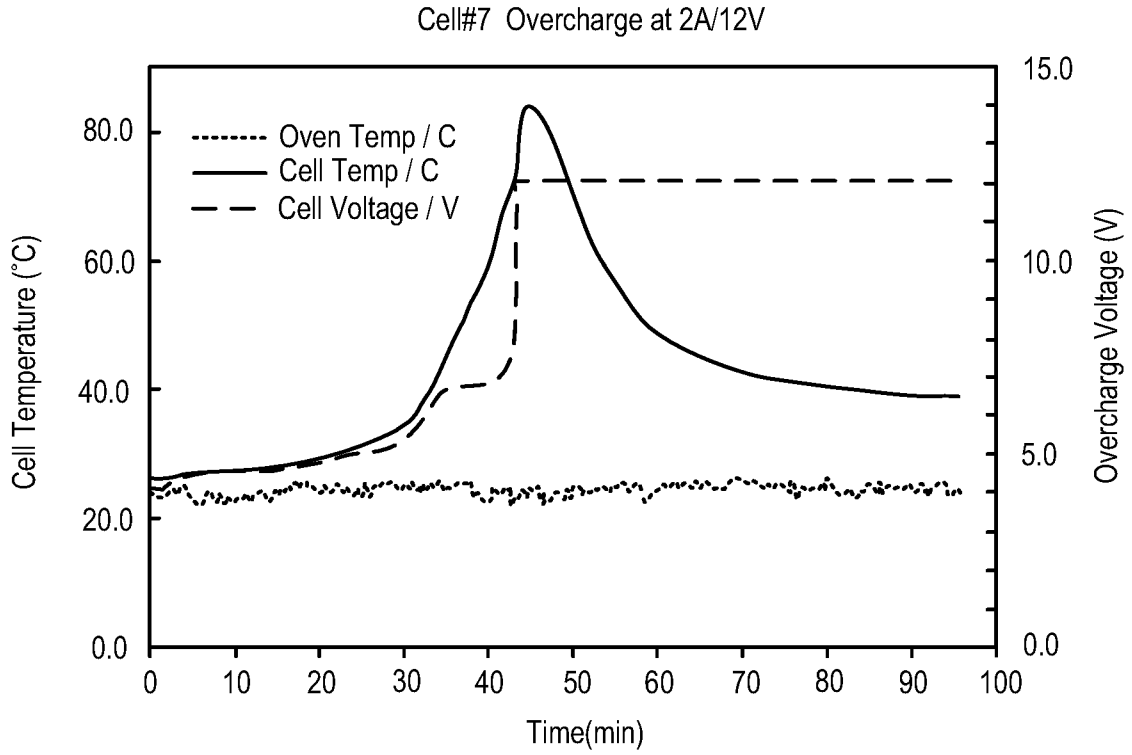

FIG. 35

Cell No.	Impedance (mohm)	Cap. At 1A (Ah)	Cap. At 3A (Ah)	Cap. At 6A (Ah)	Cap. At 10A (Ah)	Ratio (Cap. At 3A/Cap.At/1A)	Ratio (Cap. At 6A/Cap.At/1A)	Ratio (Cap. At 10A/Cap.At/1A)
1	14	2.32	2.24	2.13	1.93	0.97	0.95	0.91
3	25.8	2.9117	2.8172	2.6473	2.3289	0.97	0.94	0.88
4	89	1.756	1.096	0.023	0	0.62	0.02	0
5	15.8	2.3383	2.2495	2.1446	1.967	0.96	0.95	0.92
6	16	2.416	2.379	2.3	2.06	0.98	0.97	0.9

FIG. 36

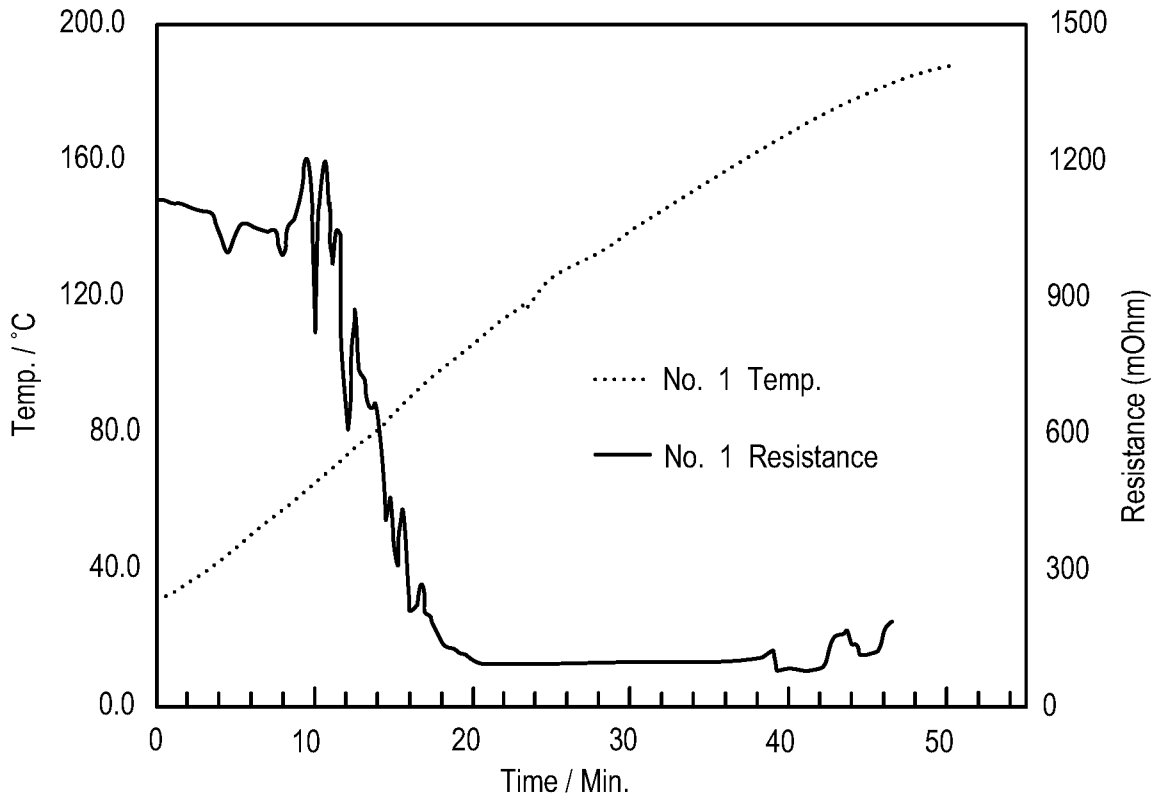

FIG. 37

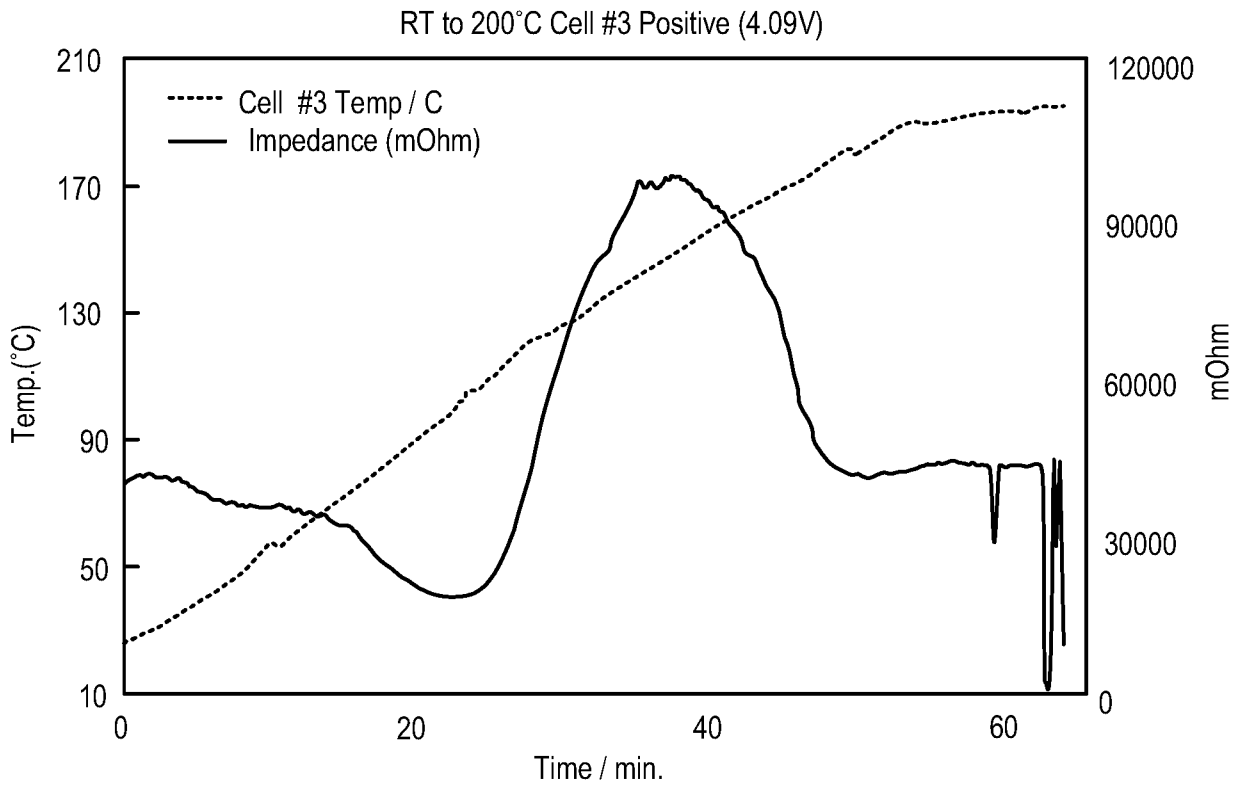

FIG. 38

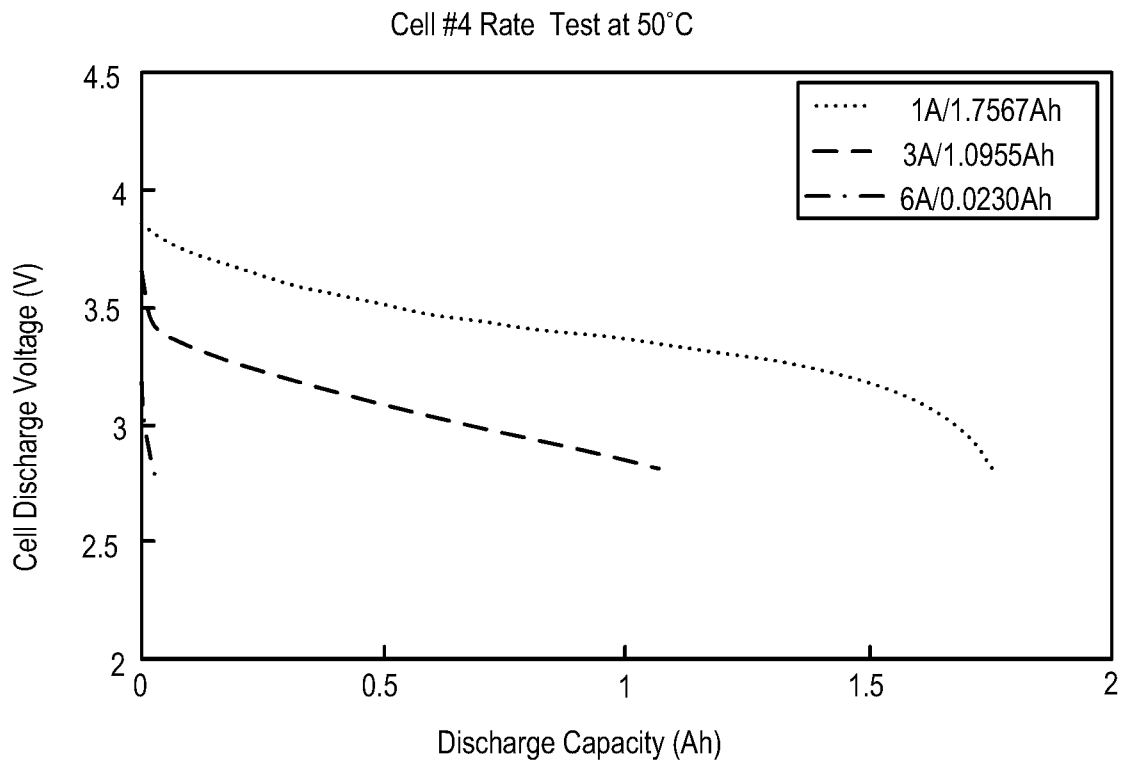

FIG. 39

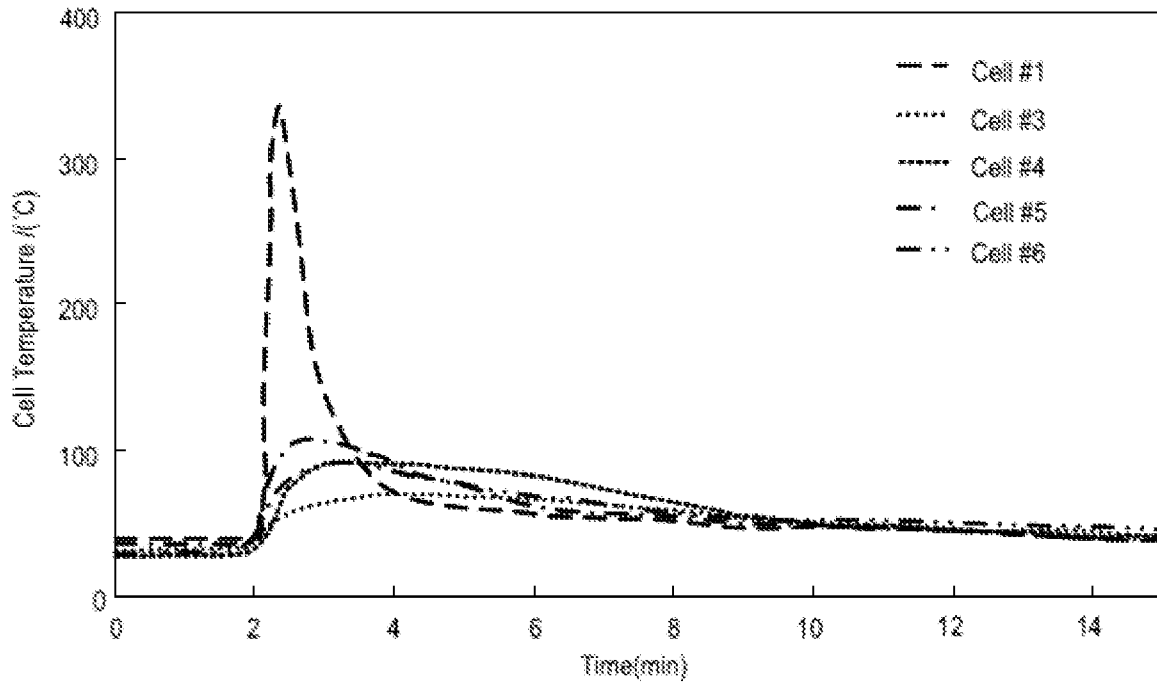

FIG. 40

Cell No.	Maximum Cell Temperature/°C	Comments
1	334	fire & explosion
3	70	pass
4	90	pass
5	106	pass
6	90	pass

FIG. 41

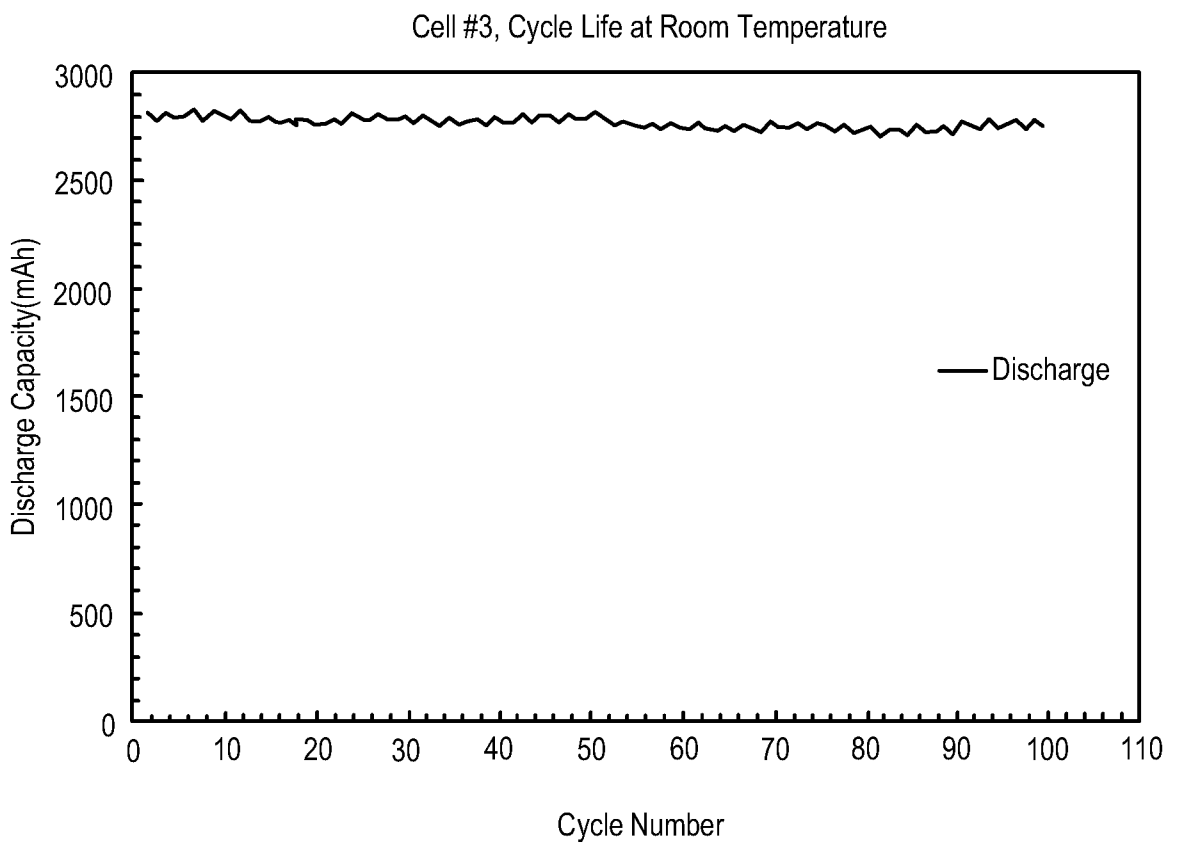
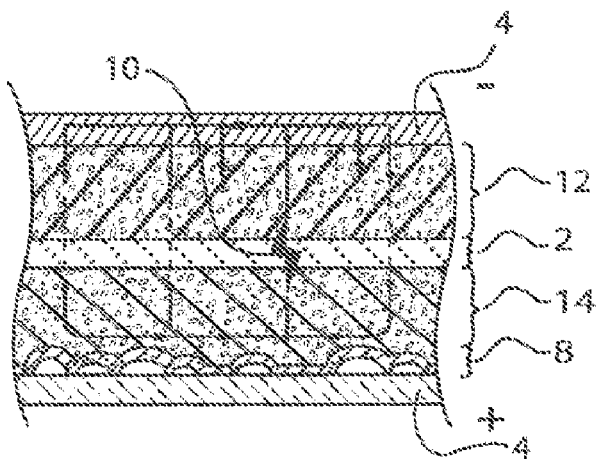

FIG. 42



Shorted