



(19) **United States**
(12) **Patent Application Publication**
Thermond et al.

(10) **Pub. No.: US 2012/0069762 A1**
(43) **Pub. Date: Mar. 22, 2012**

(54) **WIRELESS ACCESS POINT SERVICE
COVERAGE AREA MANAGEMENT**

continuation of application No. 10/357,795, filed on
Feb. 4, 2003, now Pat. No. 7,394,796.

(75) Inventors: **Jeffrey L. Thermond**, Saratoga,
CA (US); **Richard G. Martin**,
Morgan Hill, CA (US); **Jeff**
Abramowitz, Menlo Park, CA
(US); **Stephen Palm**, Irvine, CA
(US)

(60) Provisional application No. 60/398,744, filed on Jul.
26, 2002.

Publication Classification

(73) Assignee: **BROADCOM CORPORATION**,
IRVINE, CA (US)

(51) **Int. Cl.**
H04W 24/00 (2009.01)
H04W 52/04 (2009.01)
H04L 12/26 (2006.01)

(21) Appl. No.: **13/306,116**

(52) **U.S. Cl.** **370/252**

(22) Filed: **Nov. 29, 2011**

(57) **ABSTRACT**

Related U.S. Application Data

(63) Continuation of application No. 13/086,276, filed on
Apr. 13, 2011, now Pat. No. 8,085,748, which is a
continuation of application No. 12/127,513, filed on
May 27, 2008, now Pat. No. 7,948,956, which is a

A wireless terminal serviced by a Wireless Access Point
(WAP) of a Wireless Local Area Network (WLAN) infra-
structure includes a processor, an RF unit and a directional
antenna. The RF unit receives instructions from the WAP that
are derived from participatory data based on communications
involving the WAP and non-participatory data based on com-
munications the WAP listens to, but does not participate in.
The processor alters a gain vector of the directional antenna
based on the instructions received from the WAP.

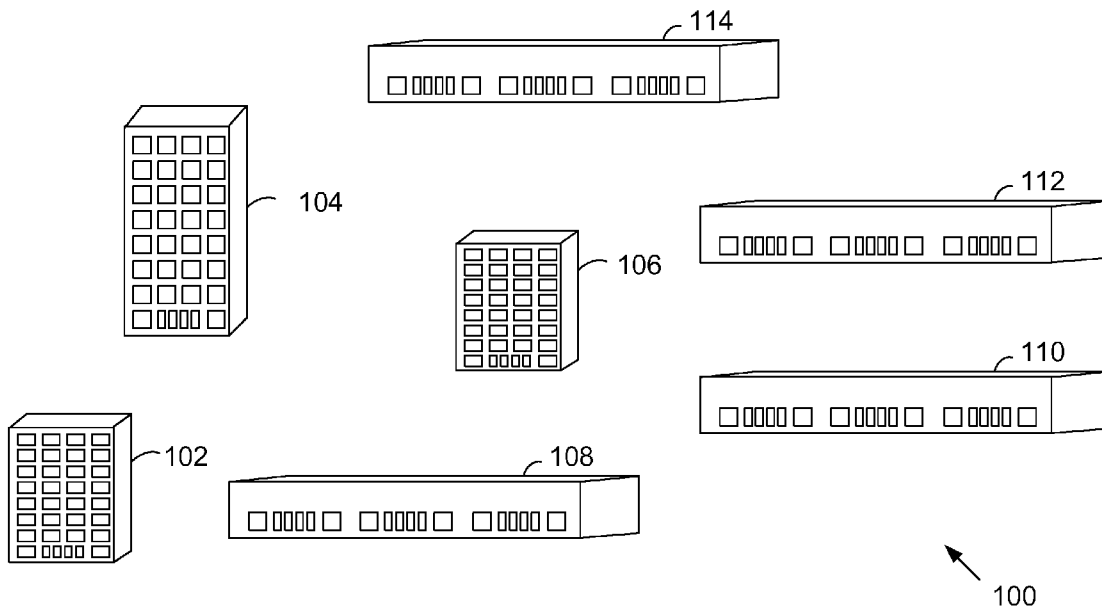

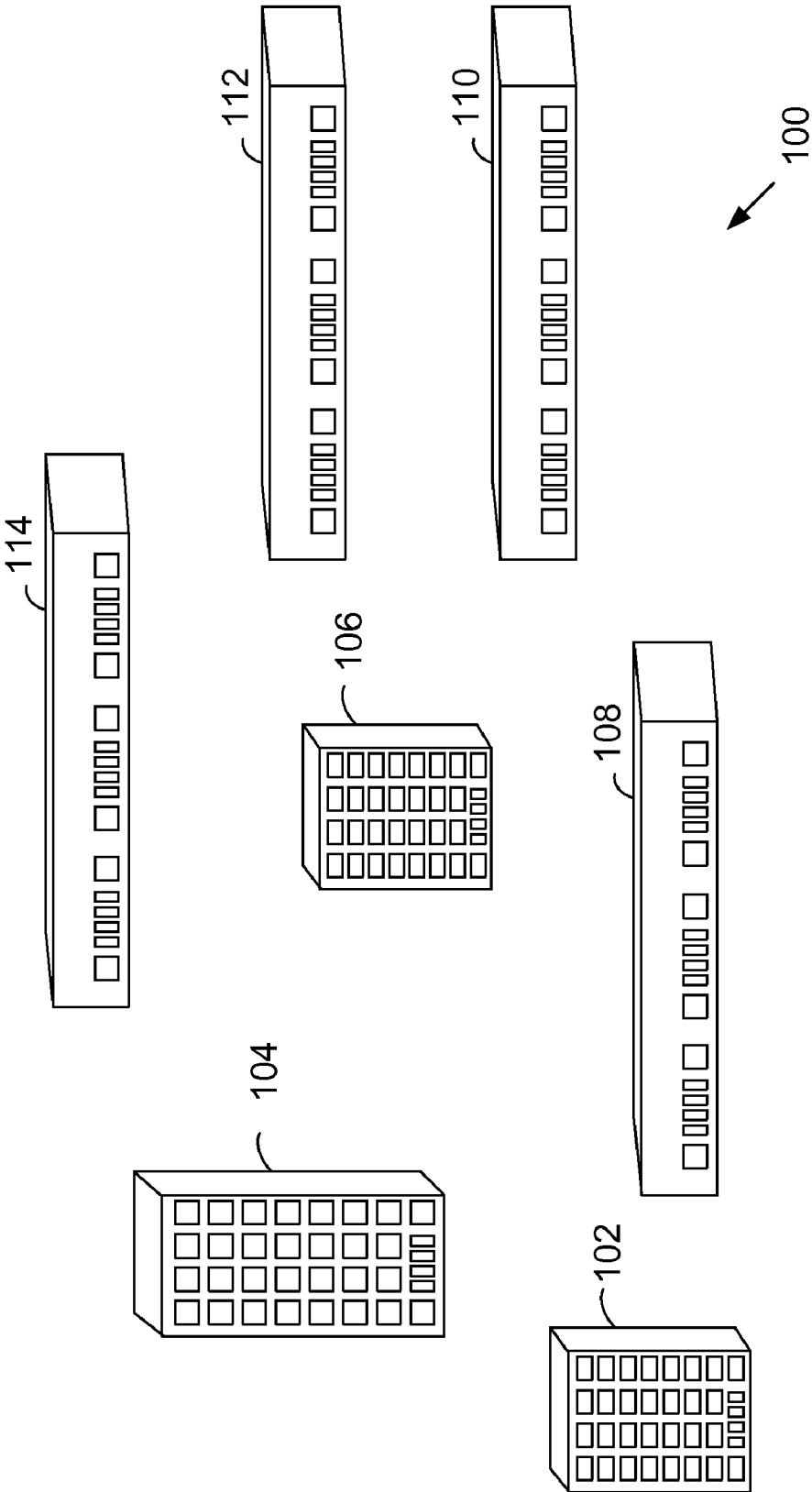

FIG. 1

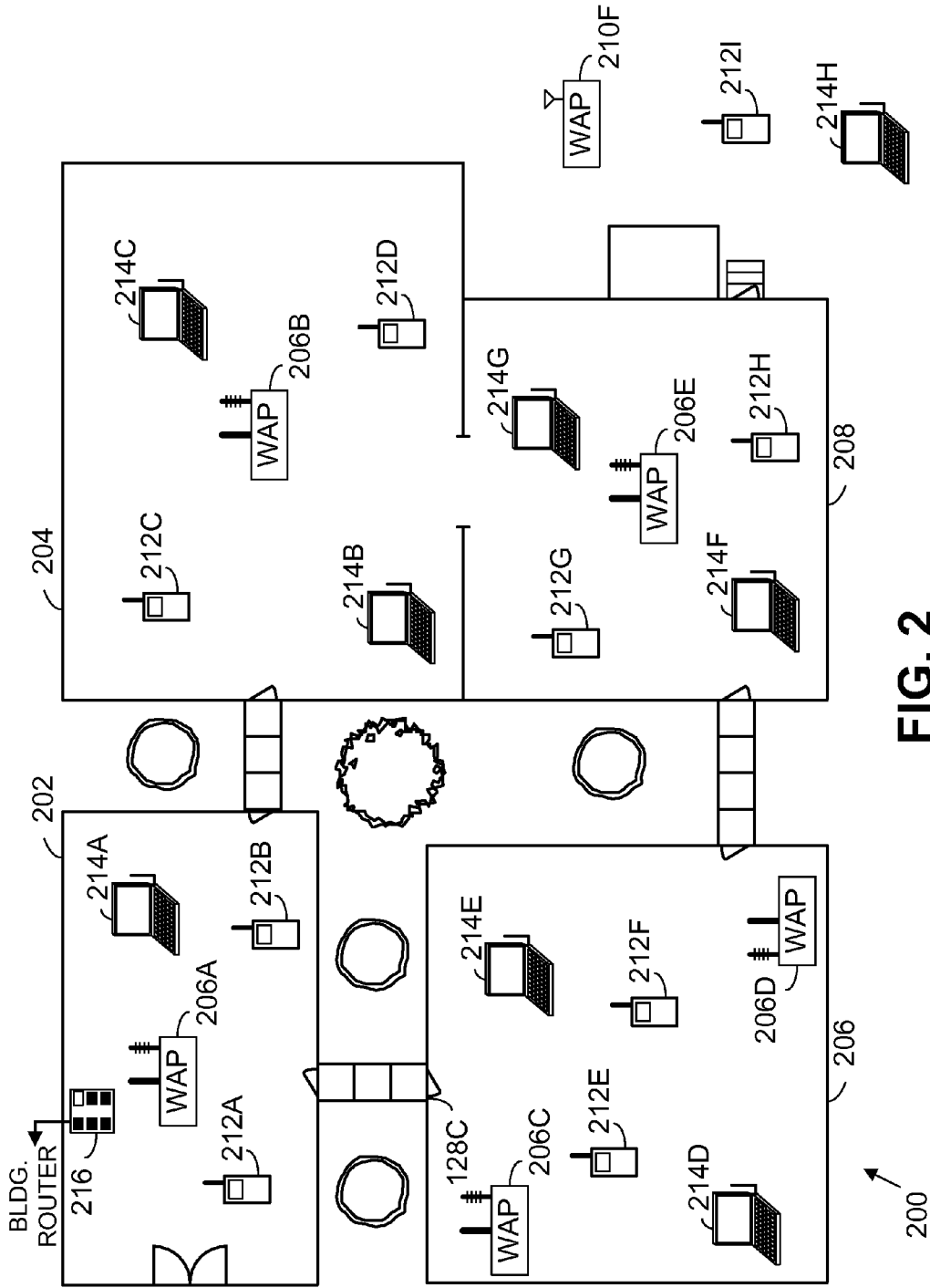

FIG. 2

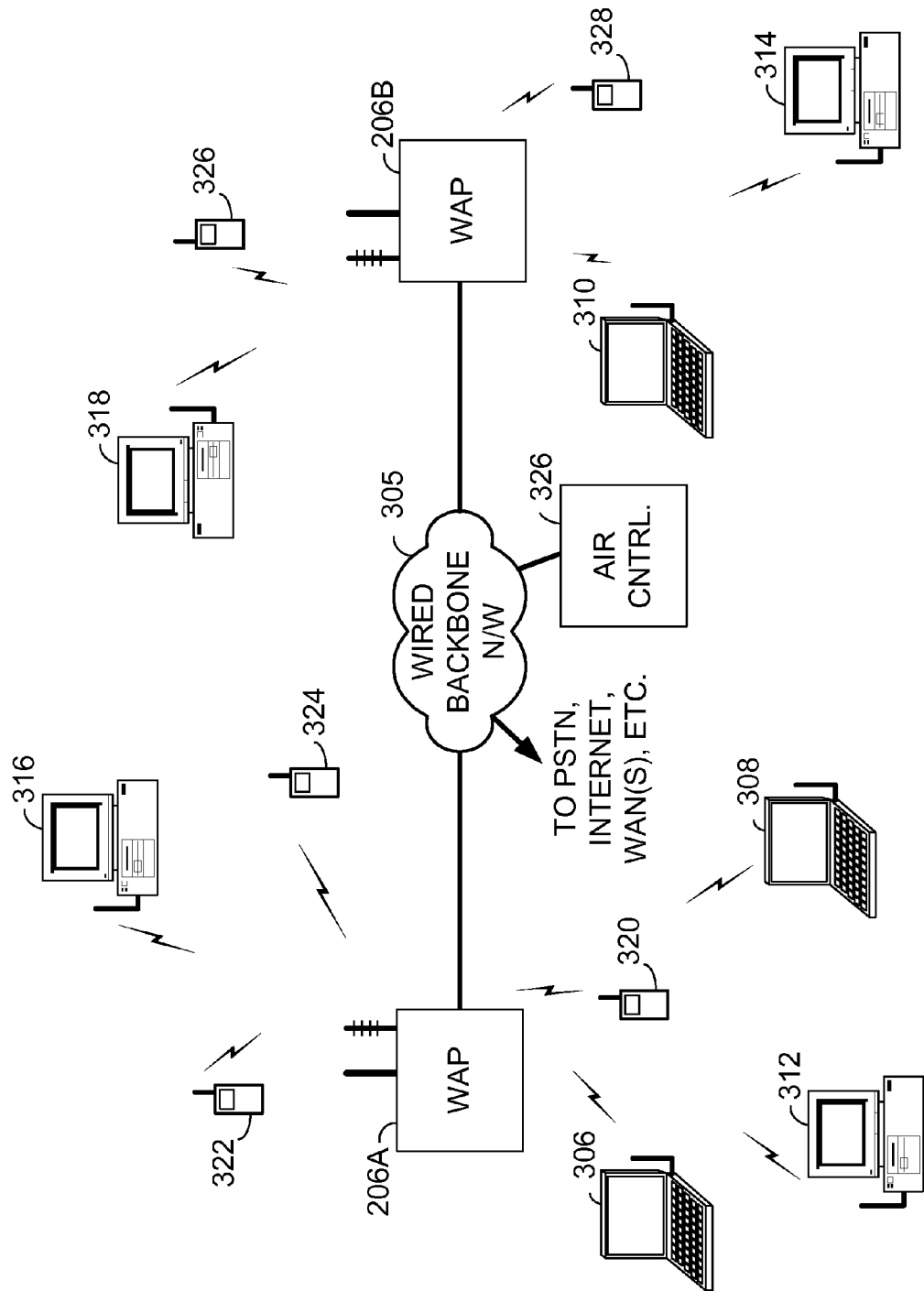

FIG. 3

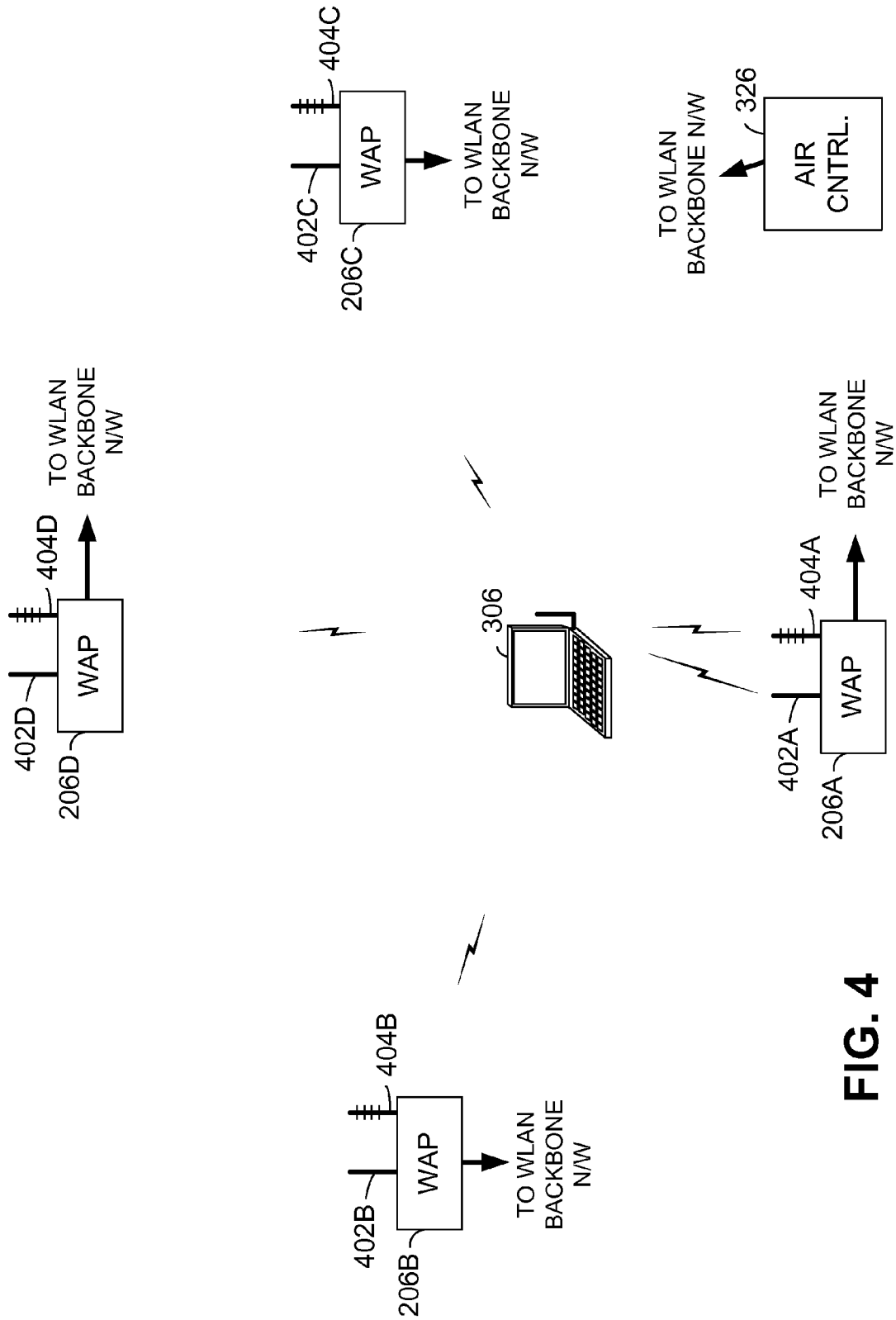

FIG. 4

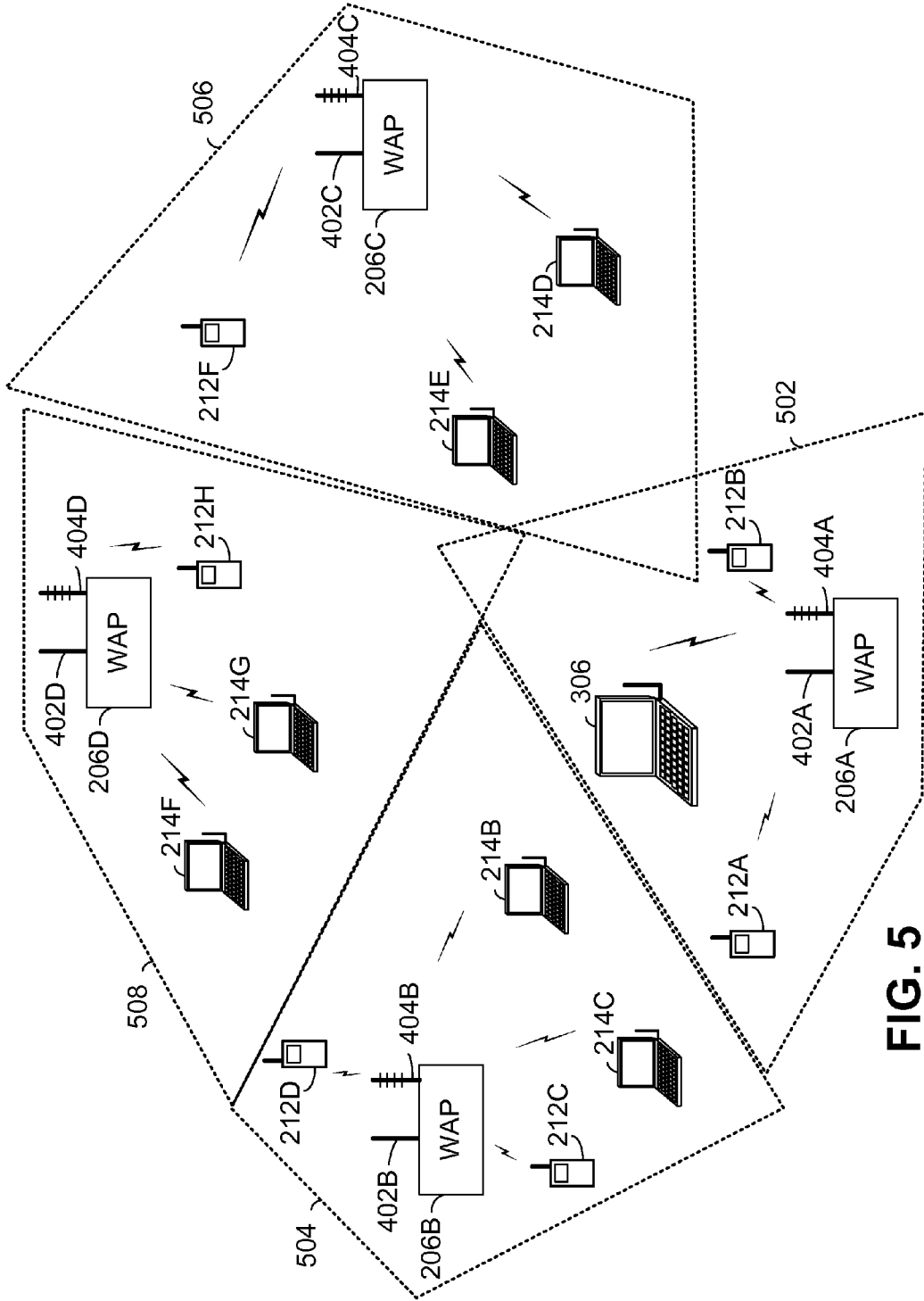

FIG. 5

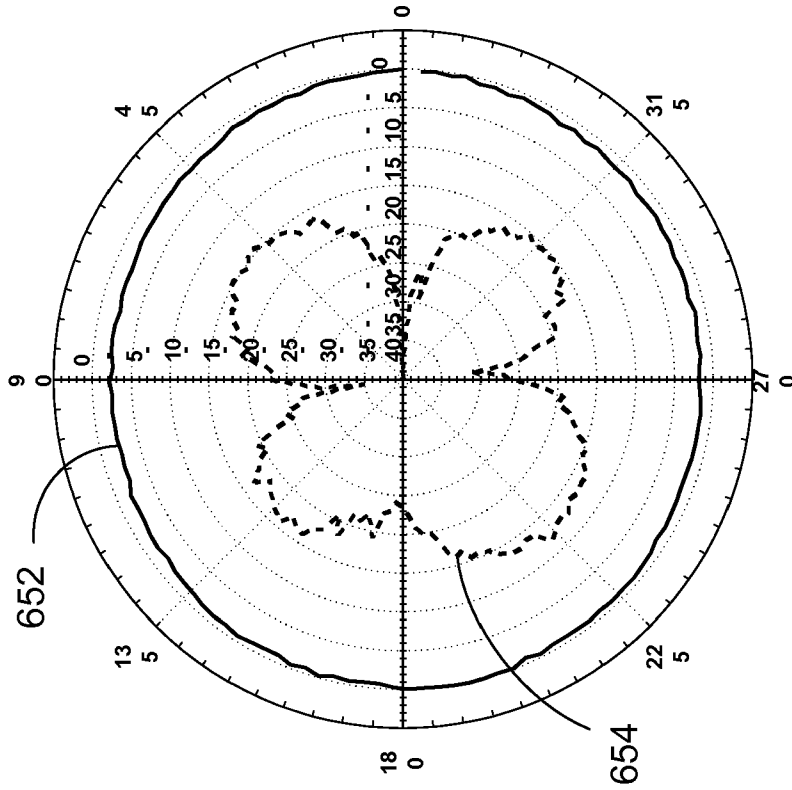

FIG. 6B

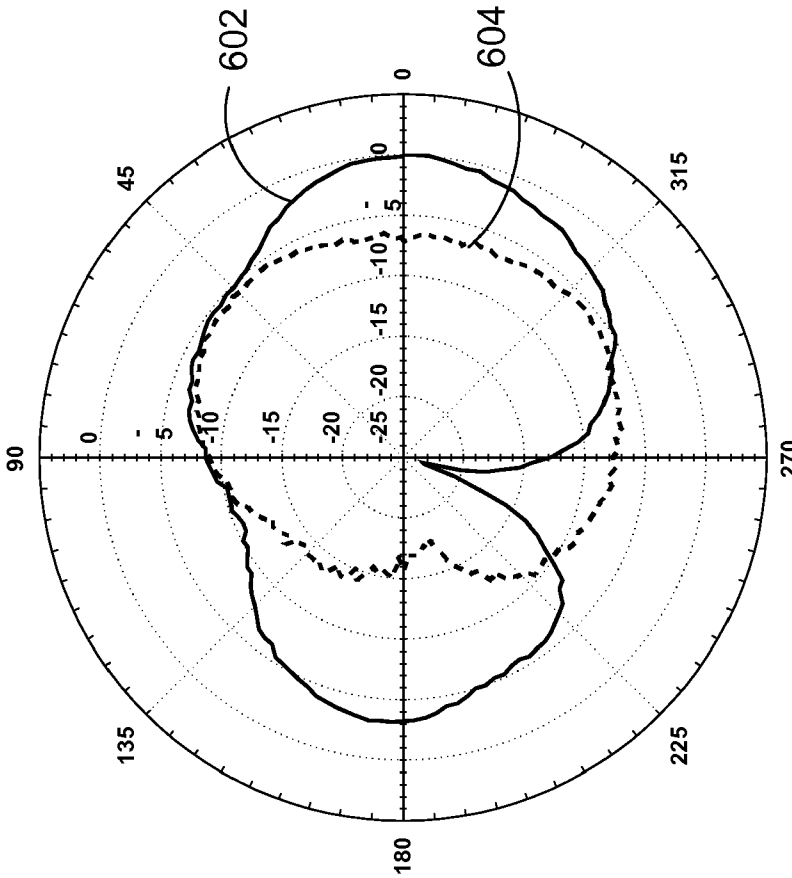

FIG. 6A

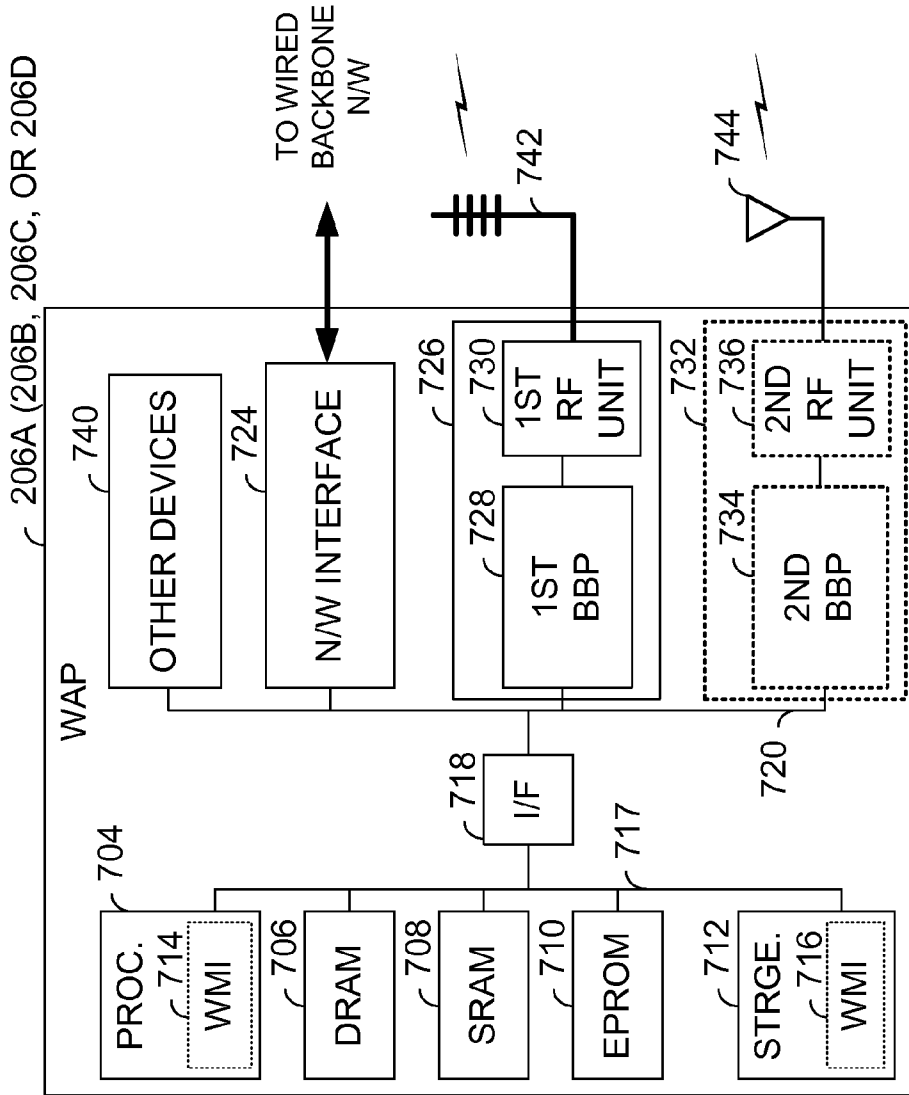

FIG. 7A

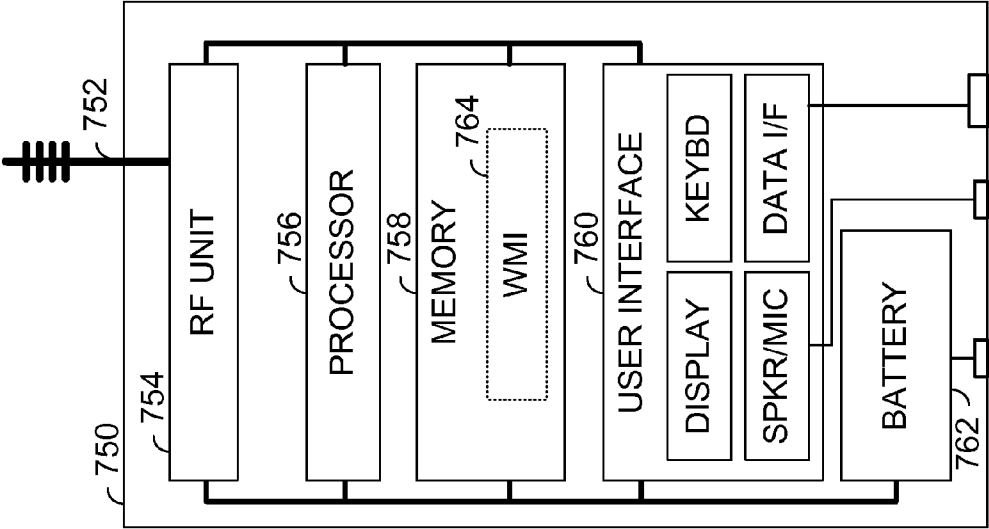

FIG. 7B

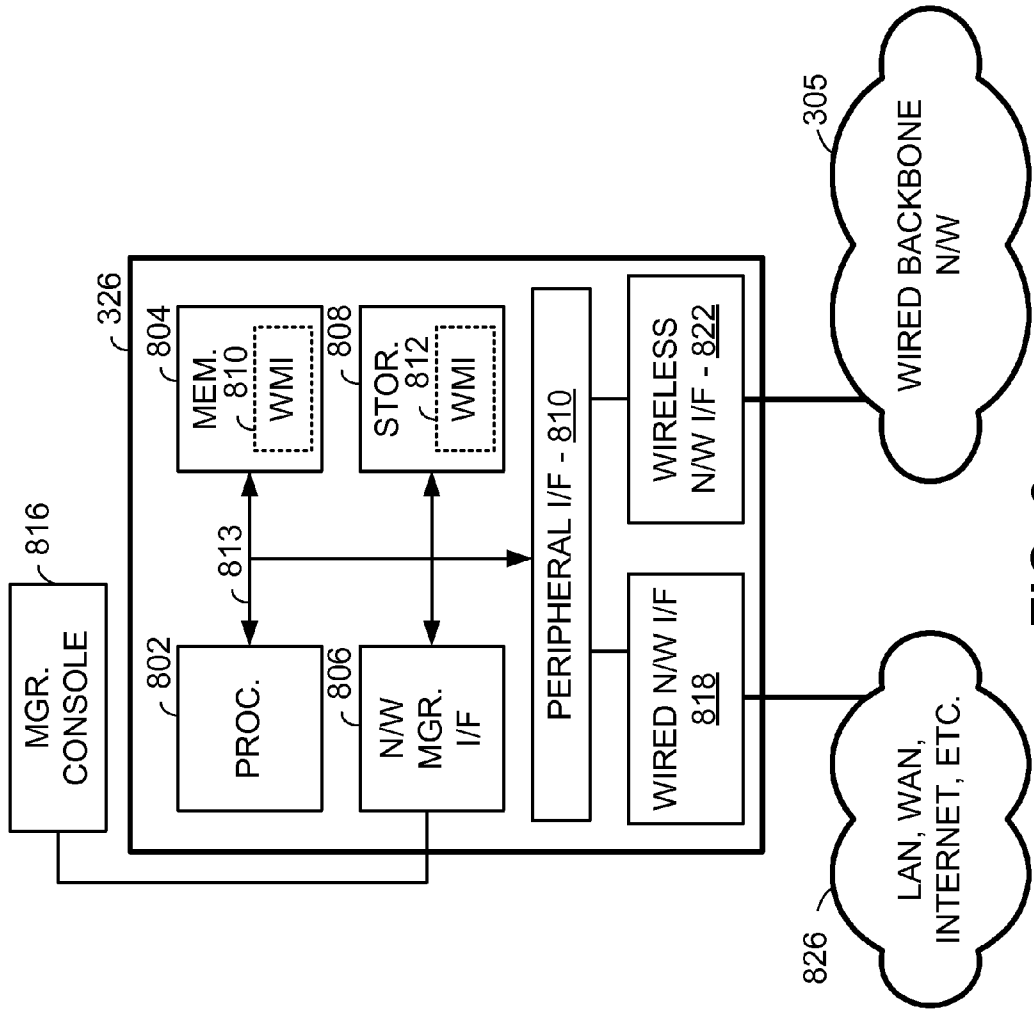

FIG. 8

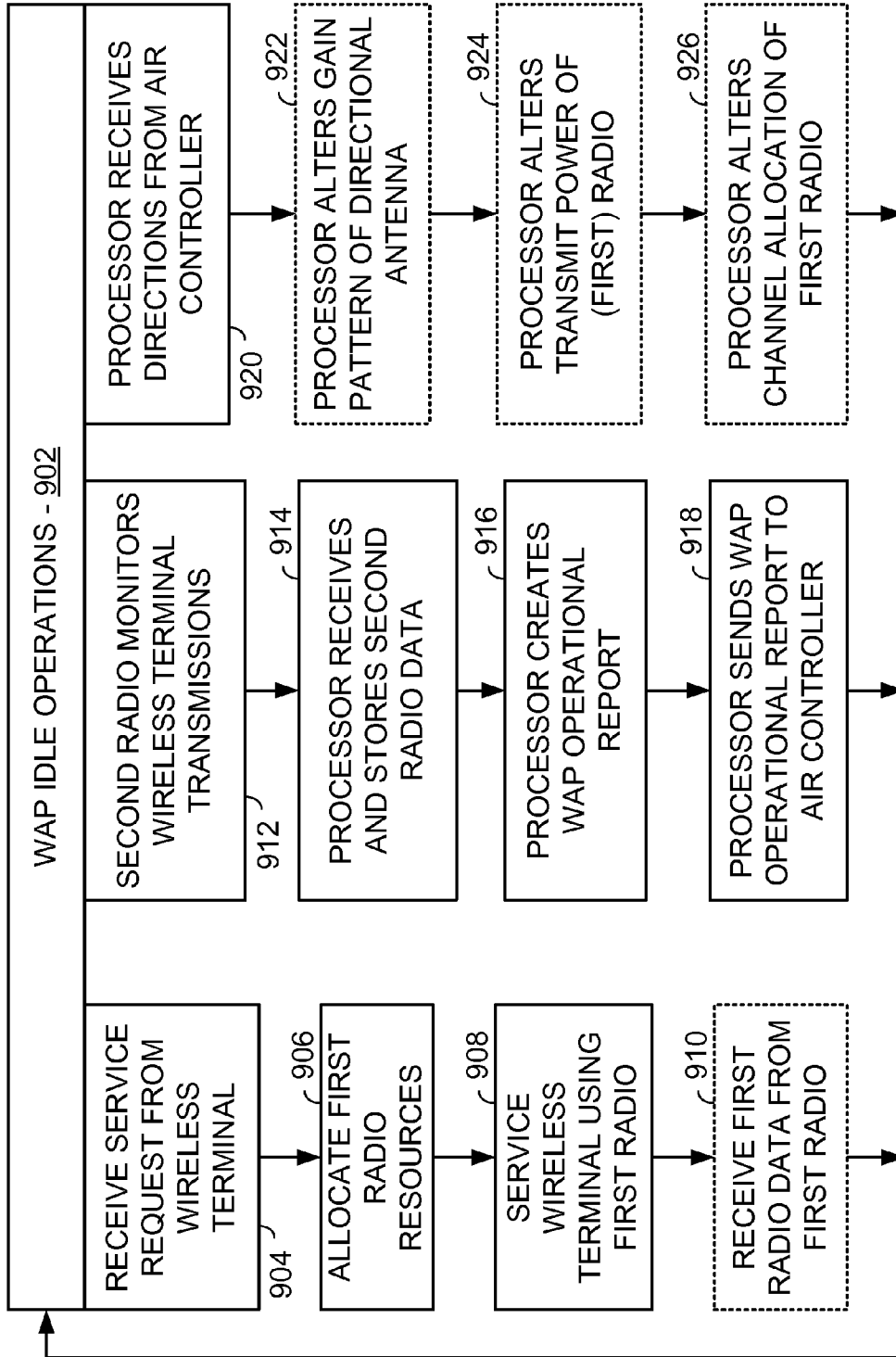

FIG. 9A

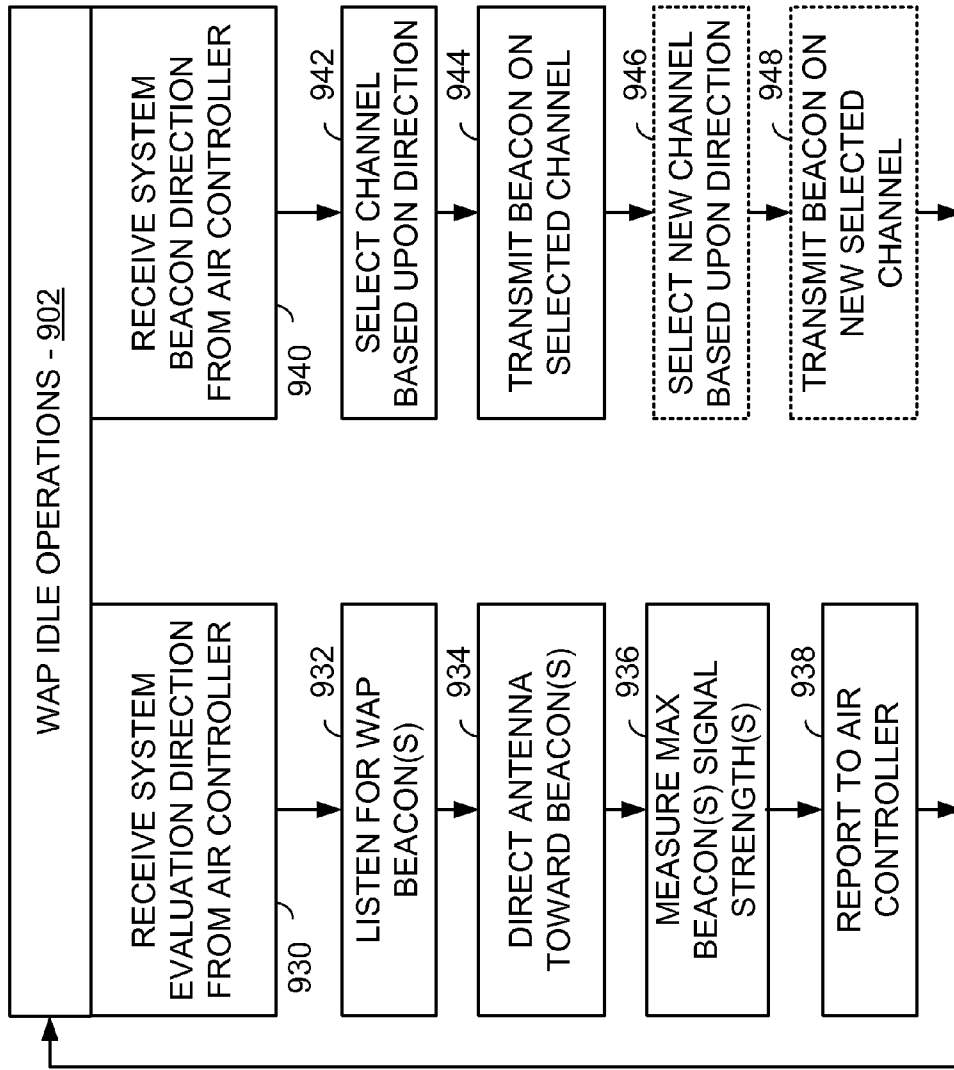

FIG. 9B

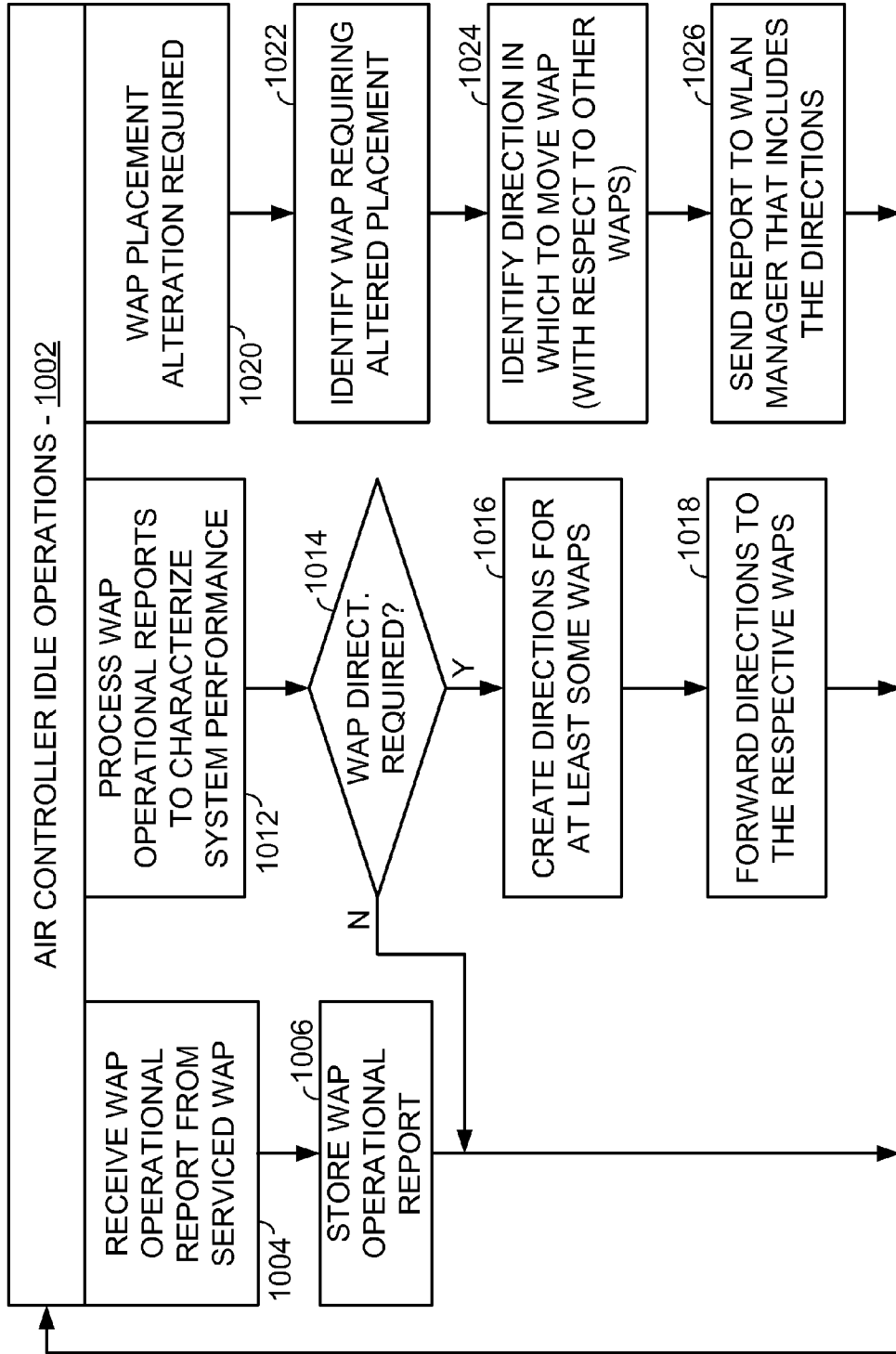

FIG. 10

**WIRELESS ACCESS POINT SERVICE
COVERAGE AREA MANAGEMENT**

**CROSS REFERENCE TO RELATED
APPLICATIONS**

[0001] The present U.S. Utility patent application claims priority pursuant to 35 U.S.C. §120, as a continuation, to the following U.S. Utility patent application, which is incorporated herein by reference in its entirety and made part of the present U.S. Utility patent application for all purposes:

[0002] 1. U.S. Utility application serial Ser. No. 13/086,276, entitled “WIRELESS ACCESS POINT SERVICE COVERAGE AREA MANAGEMENT,” (Attorney Docket No. BP2488C2), filed Apr. 13, 2011, pending, which claims priority pursuant to 35 U.S.C. §120, as a continuation, to the following U.S. Utility patent application, which is incorporated herein by reference in its entirety and made part of the present U.S. Utility patent application for all purposes:

[0003] A. U.S. Utility application Ser. No. 12/127,513, entitled “WIRELESS ACCESS POINT SERVICE COVERAGE AREA MANAGEMENT,” (Attorney Docket No. BP2488C1), filed May 27, 2008, now U.S. Pat. No. 7,948,956, which claims priority pursuant to 35 U.S.C. §120, as a continuation, to the following U.S. Utility patent application, which is hereby incorporated herein by reference in its entirety and made part of the present U.S. Utility patent application for all purposes:

[0004] i. U.S. Utility application Ser. No. 10/357,795, entitled “WIRELESS ACCESS POINT SERVICE COVERAGE AREA MANAGEMENT,” (Attorney Docket No. BP2488), filed Feb. 3, 2003, now U.S. Pat. No. 7,394,796, which claims priority pursuant to 35 U.S.C. §119(e) to the following U.S. Provisional Patent Application which is hereby incorporated herein by reference in its entirety and made part of the present U.S. Utility patent application for all purposes:

[0005] a. U.S. Provisional Patent Application Ser. No. 60/398,744, filed Jul. 26, 2002.

1. FIELD OF THE INVENTION

[0006] This invention relates generally to wireless local area networks; and more particularly to the management of wireless access points within such wireless local area networks.

2. BACKGROUND OF THE INVENTION

[0007] Communication technologies that link electronic devices in a networked fashion are well known. Examples of communication networks include wired packet data networks, wireless packet data networks, wired telephone networks, wireless telephone networks, and satellite communication networks, among other networks. These communication networks typically include a network infrastructure that services a plurality of client devices. The Public Switched Telephone Network (PSTN) is probably the best-known communication network that has been in existence for many years. The Internet is another well-known example of a communication network that has also been in existence for a number of years. These communication networks enable client devices to communicate with each other on a global basis. Wired Local Area Networks (LANs), e.g., Ethernets, are also quite common and support communications between net-

worked computers and other devices within a serviced area. LANs also often link serviced devices to Wide Area Networks and the Internet. Each of these networks is generally considered a “wired” network, even though some of these networks, e.g., the PSTN, may include some transmission paths that are serviced by wireless links.

[0008] Wireless networks have been in existence for a relatively shorter period. Cellular telephone networks, wireless LANs (WLANs), and satellite communication networks, among others, are examples of wireless networks. Relatively common forms of WLANs are IEEE 802.11(a) networks, IEEE 802.11(b) networks, and IEEE 802.11(g) networks, referred to jointly as “IEEE 802.11 networks.” In a typical IEEE 802.11 network, a wired backbone network couples to a plurality of Wireless Access Points (WAPs), each of which supports wireless communications with computers and other wireless terminals that include compatible wireless interfaces within a serviced area. The wired backbone network couples the WAPs of the IEEE 802.11 network to other networks, both wired and wireless, and allows serviced wireless terminals to communicate with devices external to the IEEE 802.11 network.

[0009] WLANs provide significant advantages when servicing portable devices such as portable computers, portable data terminals, and other devices that are not typically stationary and able to access a wired LAN connection. However, WLANs provide relatively low data rate service as compared to wired LANs, e.g., IEEE 802.3 networks. Currently deployed wired networks provide up to one Gigabit/second bandwidth and relatively soon, wired networks will provide up to 10 Gigabit/second bandwidths. However, because of their advantages in servicing portable devices, WLANs are often deployed so that they support wireless communications in a service area that overlays with the service area of a wired network. In such installations, devices that are primarily stationary, e.g., desktop computers, couple to the wired LAN while devices that are primarily mobile, e.g., laptop computers, couple to the WLAN. The laptop computer, however, may also have a wired LAN connection that it uses when docked to obtain relatively higher bandwidth service.

[0010] When a decision is initially made to install a WLAN in a premises, the WLAN must first be engineered. In such engineering, the lay out of the premises, e.g., warehouse, office space, campus environment, etc. is first considered. In most installations, wireless coverage is desired across all areas of the premises. The deployment of the WAPs within the premises is the most critical step in the WLAN engineering. Because the conductance of Radio Frequency (RF) transmissions through building walls and other obstacles in the premises is dependent upon respective structure, the structural aspects of the premises must be carefully considered when determining WAP placement. However, most WAP placement decisions are subjectively made, based upon the care and experience level of the installer.

[0011] During the initial WLAN installation, the WAP placement is fixed. Thus, the WAP placement cannot address changes in the topology and structure of the premises. Such changes in the topology and structure may include the addition of walls, the additions of partitions, the addition of wiring that will affect propagation of RF transmissions, and other characteristics. Problems that typically result due to poor WAP placement include poor channel utilization, interference between WAPs, WAP capacity shortages, and other shortcomings. These operational problems, however, will

typically only be seen as poor WLAN performance. The WLAN network installer/administrator, however, has no way of determining whether these problems are caused by equipment deficiencies, the nature of the premises, WAP placement, or lack of capacity in the WAPs.

[0012] Thus, there is a need in the art for improvements in the management of WAPs servicing a WLAN within a premises.

SUMMARY OF THE INVENTION

[0013] The present invention is directed to an apparatus and methods of operation that are further described in the following Brief Description of the Drawings, the Detailed Description of the Drawings, and the Claims. Other features and advantages of the present invention will become apparent from the following detailed description of the invention made with reference to the accompanying drawings.

BRIEF DESCRIPTION OF THE DRAWINGS

[0014] These and other features, aspects and advantages of the present invention will be more fully understood when considered with respect to the following detailed description, appended claims and accompanying drawings wherein:

[0015] FIG. 1 is a system diagram illustrating a premises in which a Wireless Local Area Network (WLAN) constructed according to the present invention is deployed;

[0016] FIG. 2 is a partial system diagram illustrating a portion of the campus of FIG. 1 in which wireless communications are serviced according to the present invention;

[0017] FIG. 3 is a partial system diagram illustrating a portion of a campus in which wireless communications are serviced according to the present invention;

[0018] FIG. 4 is a partial system diagram illustrating a WLAN constructed according to the present invention;

[0019] FIG. 5 is a partial system diagram illustrating in more detail the WLAN of FIG. 4;

[0020] FIGS. 6A and 6B are graphs illustrating various antenna gain patterns of WAP directional antennas operating according to the present invention;

[0021] FIG. 7A is a block diagram illustrating a WAP constructed according to the present invention;

[0022] FIG. 7B is a block diagram illustrating the components of a wireless terminal that operates according to the present invention;

[0023] FIG. 8 is a block diagram illustrating an air controller constructed according to the present invention;

[0024] FIGS. 9A and 9B are a logic diagrams illustrating WAP operations according to the present invention; and

[0025] FIG. 10 is a logic diagram illustrating air controller operations according to the present invention.

DETAILED DESCRIPTION OF THE DRAWINGS

[0026] FIG. 1 is a system diagram illustrating a premises 100 in which a Wireless Local Area Network (WLAN) constructed according to the present invention is deployed. The premises 100 (campus) includes office buildings 102, 104, 106 and industrial buildings 108, 110, 112, and 114. The premises 100 may correspond to a company such as a technology company, a seller of goods, a service company, or another type of company. Contained within each of the office buildings 102, 104, and 106 are a number of offices, each of which provides a working space for at least one person. Each of the industrial buildings 108, 110, 112, and 114 provides

space for manufacturing, storage, and/or another purpose. People also work within industrial buildings 108, 110, 112, and 114.

[0027] Contained within each of these buildings 102-114 are computer workstations, computer servers, printers, FAX machines, phones, and other electronic devices. Each of these electronic devices has its communication requirements. For example, computer workstations, computer servers, and printers each require data communication service. Such data communication service requires that the devices can communicate with other devices located within the premises 100 and with devices located external to the premises 100 across one or more data networks. The FAX machines and phones require coupling to one another and to the Public Switched Telephone Network (PSTN).

[0028] FIG. 2 is a partial system diagram illustrating a portion of the campus of FIG. 1 in which wireless communications are serviced according to the present invention. A building floor 200 shown in FIG. 2 may be a lower floor of one of the buildings of FIG. 1, e.g., building 102. The building floor 200 includes a plurality of rooms 202, 204, 206, and 208. Each of these rooms 202, 204, 206, and 208 has placed therein WAPs 206A, 206B, 206C, 206D, and 206E, respectively, that service corresponding areas. Further, an external WAP 206F services an area external to room 208 of building floor 200. Each of these WAPs 206A-206F couples to a wired network infrastructure that may include a building router 216.

[0029] Serviced within the building floor 200 are wireless telephones/data terminals 212A-212I and laptop computers 214A-214H, together "wireless terminals." Each of these wireless terminals wirelessly communicates with a servicing WAP. For example, laptop computer 214A and wireless terminals 212A and 212B wirelessly communicate with WAP 206A (in their illustrated positions). Each of the WAPs 206A-206E supports wireless communications primarily within a designated area respectively. However, the coverage area of each WAP 206A-206E extends beyond the boundaries of the serviced rooms 202-208 so that overlapping coverage areas exist. For example, WAPs 206A and 206C provide service between rooms 202 and 206 so that wireless terminals that roam between the rooms continue to receive wireless communication service when between the rooms 202 and 206. Further, WAP 206E supports wireless communications outside of the floor 200 to service laptop computer 214H and wireless terminal 212I.

[0030] FIG. 3 is a block diagram partially illustrating a portion of the WLAN of FIG. 2 that supports operations according to the present invention. The portion of the network shown includes WAPs 206A and 206B that support wireless communications within a serviced area, for example, the rooms 202 and 204 of FIG. 2. The WAPs 206A and 206B couple to a wired backbone network 305. The WAPs 206A and 206B service wireless communications for laptop computers 306, 308, and 310, desktop computers 312, 314, 316, and 318, and wireless telephones/data terminals 320, 322, 324, 326, and 328, together "wireless terminals." Note that while different numbering is used for the wireless terminals of FIG. 3, they are the same as, or similar to wireless terminals of FIG. 2. Service coverage areas supported by WAPs 206A and 206B partially overlap. The wired backbone network 305 couples to one or more data networks and to an air controller 326.

[0031] As illustrated, each of the WAPs 206A and 206B includes two antennas. A first antenna of the two antennas is

a dynamically directional antenna that couples to a first radio of a respective WAP and a second antenna of the two antennas couples to a second radio of a respective WAP. The directional antennas and first radios of the WAPs 206A and 206B service wireless communications with those of the laptop computers 306, 308, and 310, desktop computers 312, 314, 316, and 318, and wireless telephones/data terminals 320, 322, 322, 324, 326, and 328, together “wireless terminals,” operating within respective service areas. As will be described further with reference to FIGS. 4-10, the WAPs 206A and 206B are controlled by the air controller 326 so that their respective service areas do not unduly interfere with one another and such that satisfactory service is provided therein. In such case, each of WAPs 206A and 206B provides service to a subset of the wireless terminals.

[0032] In controlling the WAPs 206A and 206B, the air controller 326 directs the WAPs 206A and 206B to alter the gain pattern of their directional antennas, to modify their first radio transmit powers, and to alter the channels upon which they operate, among other directions. The control of the WAPs 206A and 206B by the air controller 326 is based upon WAP operational reports received from the WAPs. Second radios of the WAPs 206A and 206B listen to transmissions from at least one of the wireless terminals and WAPs and collect non-participatory WAP data. The WAPs 206A and 206B produce the WAP operational reports based upon the non-participatory WAP data and forward the WAP operational reports to the air controller 326. In some operations, the WAP operational reports may also include information gathered by the WAPs 206A and 206B based upon the communications serviced by the first radio—participatory WAP data. Participatory WAP data may include received carrier signal strengths, carrier to interference ratios, bit error rates, dropped link occurrences, and channel utilization. Non-participatory WAP data may include received carrier signal strengths, carrier to interference ratios, and channel utilizations. Based upon the WAP operational reports, the air controller 326 controls the service areas of the plurality of WAPs 206A and 206B. Resultantly, the air controller 326 reduces Radio Frequency (RF) interference among the plurality of WAPs, ensures that coverage is provided within all desired areas of the premises, and provides specialized service when required, e.g., VoIP service.

[0033] According to another aspect of the present invention, that will be described further with reference to 7B and 7C, the WAPs 206A and 206B also control the directionality (and transmit power) of serviced wireless terminals. In performing this function, the WAPs 206A and 206B listen to the strength of the received transmissions from a managed wireless terminal, determine a gain vector for a directional antenna of the wireless terminal and have the wireless terminal control its directional antenna to meet this gain vector. Generally, the gain vector will correspond to the location of a servicing WAP, WAP 206A for example. By directing the gain of the directional antenna of the wireless terminal toward the servicing WAP 206A, interference with non-servicing WAPs is reduced and the ability of the servicing WAP 206A to service the wireless terminal is improved.

[0034] FIG. 4 is a partial system diagram illustrating a WLAN constructed according to the present invention. As shown in FIG. 4, the WAPs 206A, 206B, 206C, and 206D are located across the serviced premises. Each of the WAPs 206A through 206D and the air controller 326 couples to the wired backbone network 305 (not in FIG. 4). As is further illus-

trated, each of the WAPs 206A through 206D includes a directional antenna 404A through 404D, respectively, and a second antenna, 402A through 402D, respectively.

[0035] WAP 206A services communications with a laptop computer 306 using its first radio and its directional antenna 404A. However, according to the present invention, each of the WAPs 206A, 206B, 206C, and 206D also listens to transmissions from the laptop computer 306 (and also to transmissions from the WAP 206A in some embodiments). In these operations, the WAPs 206A through 206D use antennas 402A through 402D and second radios, respectfully, to listen to transmissions of the laptop computer 306.

[0036] As will be further described herein with reference to FIGS. 5 through 10, in listening to transmissions of the laptop computer 306 and each other transmitting wireless terminal within the service premises and other sources of interference, the WAPs generate WAP operational reports. These WAP operational reports are forwarded by the WAPs 206A through 206D to the air controller 326. Based upon the WAP operational reports the air controller produces directions which are sent to one or more of the WAPs 206A through 206D. Then, based upon its directions, the WAPs 206A through 206D alter the operations of their directional antennas 404A-404D, respectively, alter the transmission power of their first radios, and/or alter the channels of operation of the first radios. According to another aspect of the present invention, when the WAPs 206A-206D include only a single radio and a single antenna, the WAPs 206A-206D listen to transmissions of non-serviced wireless terminals when they are idle with respect to their serviced wired terminals. Thus, with the embodiment, the WAPs 206A-206D are able to collect non-participatory WAP data and participatory WAP data using a single radio.

[0037] FIG. 5 is a system diagram illustrating in more detail the WLAN of FIG. 4 that operates according to the present invention. FIG. 5 also illustrates the manner in which WAPs 206A through 206D service wireless terminals operating within the premises. As shown, WAP 206A provides RF coverage within a respective service area 502 for wireless terminals 212A, 212B, and 306. Likewise, WAP 206B provides RF coverage within a respective service area 504 for wireless terminals 212C, 212D, 214B and 214C. WAP 206C provides RF coverage within a respective service area 506 for wireless terminals 214D, 214E and 212F. Finally, WAP 206D provides RF coverage within a respective service area 508 for wireless terminals 212H, 214F, and 214G.

[0038] As is illustrated, each of the service areas 502, 504, 506, and 508 has an irregular shape. While these irregular shapes are exaggerated for the illustrative purposes of FIG. 5, each of the WAPs 206A through 206D includes directional antennas 404A through 404D, respectively, that are capable of supporting respective service areas having irregular (and unique) shapes. As was previously discussed herein, the directional antennas 404A through 404D, the transmit power provided thereto by the coupled first radios, and the channel usage of the first radios are altered via direction from the air controller. As part of this alteration process, varying the directionality of the directional antennas 404A through 404D as well as the transmit power applied to the directional antennas 404A through 404D will alter the service coverage areas 502, 504, 506, and 508 respectively. Such alteration in the service coverage areas 502 through 508 results in reduced interference among the WAPs 206A through 206D. In some operations, WAPs 206A through 206D have differing wireless ter-

minal density within their service coverage areas **502-508**. By altering these service coverage areas, the air controller equalizes load among the WAPs **206A** through **206D**. Further, by altering channel usage, varying the directionality of the directional antennas **404A** through **404D**, as well as the transmit power applied to the directional antennas **404A** through **404D** that are supported by the WAPs **206A** through **206D**, the air controller ensures that specialized service requirements, e.g. Quality of Service, VOIP service, are met.

[0039] FIGS. **6A** and **6B** are graphs illustrating various antenna gain patterns of WAP directional antennas operating according to the present invention. As illustrated in FIG. **6A**, a first antenna gain pattern **602** differs from a second antenna gain pattern **604**. However, neither gain pattern of **602** or **604** is symmetrical about the antenna. The antenna gain patterns **602** and **604** may be those provided by the directional antennas **404A** through **404D** of one of the WAPs **206A** through **206D**.

[0040] As shown in FIG. **6B**, a first antenna gain pattern **652** is substantially symmetrical. Such would be the case with a monopole or dipole antenna such as the antennas **402A** through **402D** of the WAPs **206A** through **206B** that couple to respective second radios. The second antenna gain pattern shown **654** may be a gain pattern that is produced by directional antenna **404A** through **404D** of the WAPs **206A** through **206D**.

[0041] FIG. **7A** is a block diagram illustrating a WAP **206A**, **206B**, **206C**, or **206D** constructed according to the present invention. The WAP **206A** includes a processor **704** and one or more storage devices that may include dynamic RAM **706**, static RAM **708**, EPROM **710**, and/or storage device **712**, such as a hard drive, optical drive, tape drive, etc. These components intercouple via a local bus **717** and couple to a peripheral bus **720** via an interface **718**. The processor **704** may be any type of processing device capable of executing software instructions. The processor **704** may be a single integrated circuit or a processing module including a plurality of integrated circuits.

[0042] The WAP **206A** also includes a network interface **724**, which couples the WAP **206A** to the wired backbone network **305**. The WAP **206A** also includes a first radio **726**, a second radio **732**, directional antenna **742**, and antenna **744**. The first radio **726** includes a first baseband processor **728** and a first RF unit **730** that couples to the directional antenna **742**. The second radio **732** includes a second baseband processor **734** and a second RF unit **736** that couples to antenna **744**. The embodiment of the WAP **206A** illustrated supports at least one standardized operating protocol, e.g., IEEE 802.11(a), IEEE 802.11(b), IEEE 802.11(g), etc.

[0043] In performing operations according to the present invention, the WAP **206A** may execute software instructions, i.e., WAP Management Instructions (WMI). WMI **714** enable the WAP **206A** to perform the operations of the present invention. In executing the WMI, the WMI **716** are loaded into the storage unit **712** and some or all of the WMI **714** are loaded into the processor **704** for execution. During this process, some of the WMI **716** may be loaded into the DRAM **706**. In other embodiments, however, the WAP **206A** may operate according to the present invention based upon hardware function, firmware instructions, or a combination of any/all of these.

[0044] FIG. **7B** is a block diagram illustrating the components of a wireless terminal that operates according to the present invention. The wireless terminal **750** includes a RF

unit **754**, a processor **756**, and a memory **758**. The RF unit **754** couples to a controllable directional antenna **752** that may be located internal or external to the case of the wireless terminal **750**. In the described embodiment, the processor **756** controls the directionality of the directional antenna **752**. In another embodiment, for enhanced directionality control, the wireless terminal **750** may include multiple antennas.

[0045] The processor **756** may be an Application Specific Integrated Circuit (ASIC) or another type of processor that is capable of operating the wireless terminal **750** according to the present invention. The memory **758** includes both static and dynamic components, e.g., DRAM, SRAM, ROM, EEPROM, etc. In some embodiments, the memory **758** may be partially or fully contained upon an ASIC that also includes the processor **756**. A user interface **760** includes a display, indicators, a keyboard, a speaker, a microphone, and/or a data interface, and may include other user interface components. The radio **754**, the processor **756**, the memory **758**, and the user interface **760** couple via one or more communication buses/links. A battery **762** also couples to and powers the radio **754**, the processor **756**, the memory **758**, and the user interface **760**. The structure of the wireless terminal **750** illustrated is only an example of one wireless terminal structure. Many other varied wireless terminal structures could be operated according to the teachings of the present invention.

[0046] As was previously discussed, according to another aspect of the present invention, the WAPs **206A** and **206B** may also control the directionality (and transmit power) of serviced wireless terminals. In performing this function, the WAPs **206A** and **206B** listen to the strength of the received transmissions from a managed wireless terminal, determine a gain vector for a directional antenna of the wireless terminal and have the wireless terminal control its directional antenna to meet this gain vector. Generally, the gain vector will correspond to the location of a servicing WAP, WAP **206A** for example. By directing the gain of the directional antenna **752** of the wireless terminal **750** toward the servicing WAP **206A**, interference with non-servicing WAPs is reduced and the ability of the servicing WAP **206A** to service the wireless terminal is improved. The wireless terminal **750** of FIG. **7B** supports these operations.

[0047] In performing the operations of the present invention, the wireless terminal **750** may execute software instructions, i.e., WAP Management Instructions (WMI) **764**. WMI **764** enable the wireless terminal **750** to perform the operations of the present invention. In executing the WMI, the WMI **764** are loaded from memory **758** into the processor **756** for execution. In other embodiments, however, the wireless terminal **750** may operate according to the present invention based upon hardware function, firmware instructions, or a combination of any/all of these.

[0048] FIG. **8** is a block diagram illustrating an air controller **326** constructed according to the present invention. The air controller **326** may be general-purpose computer that has been programmed and/or otherwise modified to perform the particular operations described herein. The air controller **326** includes a processor **802**, memory **804**, a network manager interface **806**, storage **808** and a peripheral interface **814**, all of which couple via a processor bus **813**. The processor **802** may be a microprocessor or another type of processor that executes software instructions to accomplish programmed functions. The memory **804** may include DRAM, SRAM, ROM, PROM, EPROM, EEPROM, or another type of memory in which digital information may be stored. The

storage **808** may be magnetic disk storage, magnetic tape storage, optical storage, or any other type of device, which is capable of storing digital instructions and data.

[0049] The network manager interface **806** couples to a network manager console **816**, which allows a network manager to interface with the air controller **326**. The network manager console **816** may be a keypad/display or may be a more complex device, such as a personal computer, which allows the manager to interface with the air controller **326**. However, the network manager may interface with the air controller **326** using other techniques as well, e.g., via a card coupled to the peripheral interface **810**.

[0050] The peripheral interface **810** couples to a wired network interface **818** and to wireless network infrastructure interface **822**. The wired network interface **818** couples the air controller **326** to at least one network **826** that may include a Local Area Network (LAN), a Wide Area Network (WAN), or the Internet. The wireless network infrastructure interface **822** couples the air controller **326** to the wired backbone network **305**.

[0051] WAP Management Instructions (WMI) **812** are loaded into the storage **808** of the air controller **326**. Upon their execution, a portion of the WMI **812** is downloaded into memory **804** (as WMI **810**). The processor **802** then executes the WMI **810** to perform the operations described herein performed by the air controller **326**. The programming and operation of digital computers is generally known to perform such steps. Thus, the manner in which the processor **802** and the other components of the air controller **326** function to perform these operations is not further described herein.

[0052] FIGS. **9A** and **9B** are a logic diagrams illustrating WAP operations according to the present invention. Referring particularly to FIG. **9A**, operation of the WAP remains idle state until action according to the present invention commences (step **902**). From step **902**, the WAP may receive a service request from a wireless terminal (step **904**), may employ its second radio to monitor wireless terminal transmission (step **912**), may receive directions from an air controller (step **920**), may receive a system evaluation direction from the air controller (step **930**), or may receive a system beacon direction from the air controller (step **940**).

[0053] The WAP may receive a service request from any wireless terminal operating in the WAP's service area (step **904**). From step **904**, the WAP allocates first radio resources for servicing the wireless terminal (step **906**). The manner in which a wireless terminal requests service from the WAP and the manner in which the WAP responds may be defined according to a standardized operating protocol, e.g. IEEE 802.11(a), IEEE 802.11(b), or IEEE 802.11(g). After first radio resources are allocated, the WAP services the wireless terminal using its first radio (step **908**). In servicing the wireless terminal, the WAP may optionally receive participatory WAP data from the first radio **910**. Once the communication has been fully serviced, operation returns from **910** to step **902**.

[0054] From step **912** in which the second radio monitors wireless terminal and/or WAP transmissions, the processor of the WAP receives and stores the non-participatory WAP data (step **914**). As has been previously described, the second radio of the WAP is listens to wireless terminal and/or WAP transmissions within the WLAN. In this fashion, the second radio is able to determine when a conflict or sub optimal operating condition exists. In performing this type of listening, the second radio gathers non-participatory WAP data. Option-

ally, the first radio gathers participatory WAP data that relates to its serviced communications.

[0055] In another embodiment of the present invention, each WAP only includes a single radio. In this embodiment, the single radio collects participatory WAP data when it is actively servicing a wireless terminal and collects non-participatory WAP data when it is not actively servicing a wireless terminal but is instead merely listening. In either embodiment, the first radio and/or the second radio provide the non-participatory data (and optionally the participatory WAP data) to the processor.

[0056] After receipt of the non-participatory WAP data and optionally the participatory WAP data, the WAP creates a WAP operational report (step **916**). In particular, the processor of the WAP creates the WAP operational report. The processor then sends the WAP operational report to the air controller (step **918**). The WAP may send the WAP operational report to the air controller periodically or immediately after its creation, or upon request by the air controller. As is evidenced, the WAP operational report may not be created on a periodic fashion because of variations in loading on the WLAN. During high usage times, e.g., during the day, more participatory WAP data and non-participatory WAP data is collected than during low usage times, e.g., night time hours. Thus, the WAP operational reports may be sent from the WAP to the air controller as is required considering particular system loading conditions.

[0057] When the processor of the WAP receives directions from the air controller (at step **920**), the processor performs at least one of three different operations. In a first one of these operations, the processor alters the gain pattern of the directional antenna of the corresponding WAP (step **922**). In a second operation, the processor alters the transmit power of the first radio of the WAP (step **924**). In a third operation, the processor alters the channel allocation of the first radio (step **926**). From each of step **918** and **926**, operation returns to step **902**.

[0058] Referring now to FIG. **9B**, operations regarding WLAN system evaluation are discussed. Generally, immediately after installation, or at a subsequent time, the WLAN is evaluated for its coverage and performance. As one step of this evaluation, the relative radio positions of the WAPs of the WLAN are determined. One technique for this determination is accomplished at step **930-948**. As a first operation in this evaluation, a WAP receives a system evaluation direction from the air controller (step **930**). In response to the system evaluation direction, the WAP listens for beacons of other WAPs (step **932**). These beacons will typically be on particular channels at particular times. When the WAP hears a beacon, it controls its directional antenna in the direction of the beacon (step **934**). Then, the WAP measures the maximum signal strength of the beacon (step **936**). Steps **932**, **934**, and **936** will be repeated for each beacon. The air controller, in the system evaluation direction, may identify the beacon channels and beacon intervals to the WAPs. Alternately, the WAP will simply scan for beacons on each serviced channel, record information, and continue until directed to stop by the air controller. Finally, the WAP prepares a report regarding the beacon and provides the report to the air controller (step **938**).

[0059] At step **940**, the WAP receives a system beacon direction from the air controller (step **940**). In response to the system beacon direction, the WAP selects a channel (step **942**) and transmits a beacon on the selected channel (step **944**). In one operation, the WAP transmits in a non-direc-

tional manner. However, in another operation, the WAP transmits with a previously determined directionality. With step 944 complete, the WAP optionally selects a new channel based upon the received direction or based upon another received direction (step 946) and transmits a beacon on the new selected channel (step 948). From steps 938 and 948 operation returns to step 902.

[0060] FIG. 10 is a logic diagram illustrating air controller operations according to the present invention. When the air controller is not performing operations of the present invention, it is either idle or performing other of its operations (step 1002). During a first operation of the present invention, the air controller receives a WAP operational report from a serviced WAP (step 1004). The air controller then stores the WAP operation report in its memory (step 1006). From step 1006 operation returns to step 1002.

[0061] In a second operation from step 1002, the air controller processes the received WAP operational reports to characterize system performance of the WLAN (step 1012). Based upon this system performance characterization, the WAP determines whether WAP directions are required (step 1014). If WAP directions are not required, operation proceeds from step 1014 to step 1002. However, if WAP directions are required, the air controller creates directions for at least some of the WAPs of the serviced WLAN (step 1016). Then, the air controller forwards the directions to respective WAPs (step 1018). Because the directions may only alter operation of one of the WAPs, at step 1018, the directions are forwarded to only targeted WAPs of the plurality of WAPs of the WLAN. However, in other operations, the directions are forwarded to a number of respective WAPs that are requested to alter their operations. In still another operation, the directions are broadcast to all managed WAPs. From step 1018 operations returns to step 1002.

[0062] According to a further operation, the air controller may determine that it can no longer simply adjust operations of the WAPs but that WAP placement alterations are required (step 1020). In such case, the air controller identifies the WAP(s) requiring altered placement (step 1022). Such determination may be made by the air controller based upon its continued attempted adjustment of the WAP without producing sufficient WLAN system performance improvement. In its operations, the air controller may also identify a direction in which to move a WAP with respect to other WAPs (step 1024). The air controller then sends a report to a WLAN manager that includes directions for WAP movement (step 1026). From step 1026 operation returns to step 1002.

[0063] The invention disclosed herein is susceptible to various modifications and alternative forms. Specific embodiments therefore have been shown by way of example in the drawings and detailed description. It should be understood, however, that the drawings and description thereto are not intended to limit the invention to the particular form disclosed, but on the contrary, the invention is to cover all modifications, equivalents and alternatives falling within the spirit and scope of the present invention as defined by the claims.

1. A wireless terminal serviced by a Wireless Access Point (WAP) within a Wireless Local Area Network (WLAN) infrastructure, the wireless terminal comprising:

- a directional antenna;
- an RF unit communicatively coupled to the directional antenna and operable to receive instructions from the WAP, the instructions being derived from participatory data based on communications involving the WAP and

non-participatory data based on communications the WAP listens to, but does not participate in; and

a processor for altering a gain vector of the directional antenna based on the instructions received from the WAP.

2. The wireless terminal of claim 1, wherein the instructions are further based upon WAP operational reports created from the participatory data and non-participatory data that are provided from the WAP to the WLAN and directions received from the WLAN in response to the WAP operational reports.

3. The wireless terminal of claim 1, wherein, based upon the instructions, the processor also alters the channels of operation of the RF unit.

4. The wireless terminal of claim 3, wherein in altering the channels of operation of the RF unit, the processor directs the RF unit to operate on a reserved set of channels.

5. The wireless terminal of claim 1, further comprising:
a memory containing WAP management instructions executable by the processor to alter the gain vector of the directional antenna.

6. The wireless terminal of claim 1, wherein the directional antenna includes a plurality of directional antennas, each having a respective gain vector controllable by the processor based on the instructions.

7. The wireless terminal of claim 1, wherein the participatory WAP data is selected from the group consisting of received carrier signal strength, carrier to interference ratio, bit error rate, dropped link occurrences, and channel utilization.

8. The wireless terminal of claim 1, wherein the non-participatory WAP data is selected from the group consisting of received carrier signal strength, carrier to interference ratio, and channel utilizations.

9. The wireless terminal of claim 1, wherein the participatory data includes information on transmissions received at the WAP from the wireless terminal.

10. The wireless terminal of claim 1, wherein, based upon the instructions, the processor also alters a transmission power of the RF unit.

11. A method for operating a wireless terminal serviced by a Wireless Access Point (WAP) within a Wireless Local Area Network (WLAN) infrastructure, the method comprising:

receiving, by an RF unit of the wireless terminal, instructions from the WAP, the instructions being derived from participatory data based on communications involving the WAP and non-participatory data based on communications the WAP listens to, but does not participate in; and

altering, by a processor of the wireless terminal, a gain vector of a directional antenna of the wireless terminal based on the instructions received from the WAP.

12. The method of claim 11, wherein the instructions are further based upon WAP operational reports created from the participatory data and non-participatory data that are provided from the WAP to the WLAN and directions received from the WLAN in response to the WAP operational reports.

13. The method of claim 11, further comprising:
based upon the instructions, altering, by the processor, a transmission power of the RF unit.

14. The method of claim 11, further comprising:
based upon the instructions, altering, by the processor, channels of operation of the RF unit.

15. The method of claim **14**, wherein in altering the channels of operation of the RF unit, the method further comprises:

directing, by the processor, the RF unit to operate on a reserved set of channels.

16. The method of claim **11**, wherein the directional antenna includes a plurality of directional antennas, each having a respective gain vector controllable by the processor based on the instructions.

17. The method of claim **11**, wherein the participatory WAP data is selected from the group consisting of received

carrier signal strength, carrier to interference ratio, bit error rate, dropped link occurrences, and channel utilization.

18. The method of claim **11**, wherein the non-participatory WAP data is selected from the group consisting of received carrier signal strength, carrier to interference ratio, and channel utilizations.

19. The method of claim **11**, wherein the participatory data includes information on transmissions received by the WAP from the wireless terminal.

* * * * *