

May 29, 1956

M. D. BERGAN

2,748,366

Y-SHAPED WIRE AND CABLE TAP

Filed July 10, 1952

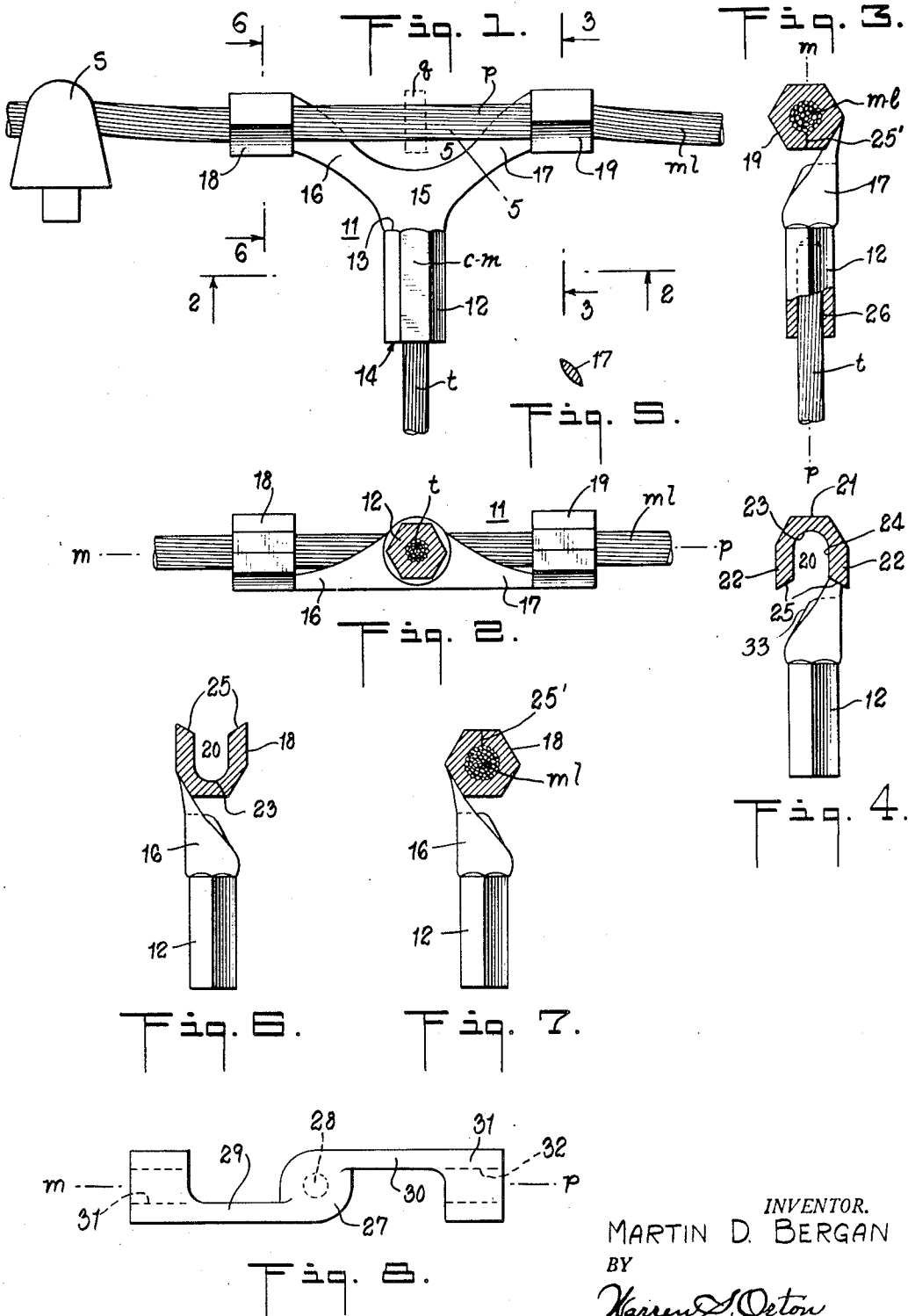

INVENTOR.
MARTIN D. BERGAN
BY
Warren S. Oetton
HIS ATTORNEY

1

2,748,366

Y-SHAPED WIRE AND CABLE TAP

Martin D. Bergan, Westfield, N. J., assignor to The Thomas & Betts Co., Elizabeth, N. J., a corporation of New Jersey

Application July 10, 1952, Serial No. 298,090

10 Claims. (Cl. 339—243)

The invention relates to a connector of the type employed for permanently securing a line tap in position depending from an overhead main line conductor to supply electric current from the main line to the tap branch.

The present disclosure features the employment of a connector or tap which can be secured permanently to a continuous run of conductor cable for tapping onto the same without cutting the cable and by reason of its appearance will be referred to hereinafter as a Y-shaped tap. While it is of Y-form it actually forms a tap of the T-type.

It is generally true in this art that the cables forming the main line conductors, as well as the line taps used therewith, are of varying sizes. In practice this has required the operator in the field to carry with him connectors of various dimensions to custom-fit each particular job, or has necessitated the use of connectors provided with adjustable means for receiving and for securing thereto the conductors, both main line and tap, used on any particular job. Connectors which require the use of screw and other forms of clamping means have not proven satisfactory as mechanically adjustable fastening means are quite apt to become loose in service due to the vibrations set up when such connectors are free to swing in space and develop poor contact after they have been in use for awhile.

The primary object of the invention is to provide for each usual size of main line conductor a standard form of one-piece connector which can be accurately preformed in the part thereof designed to engage the main line conductor to have a snug but sliding fit thereon, and in which the balance of the connector can be easily modified, as by drilling a socket therein, to accommodate within limits any desired size of tap wire; which connector when so custom-made can be deformed in both the preformed main line part as well as in the tap-engaging part by the employment of conventional crimping tools into permanent engagement with both the main line and tap; and which connector is thus particularly characterized by being permanent after it is once formed and thus is free of necessity to use any fussy adjustment mechanism.

In place of the usual adjustable screw-type means heretofore employed in this art for temporarily securing the connector to the main line conductor, the present disclosure features the use of a combined deforming wrap-down and compressing of the connector under a squeeze pressure onto the main line to permanently secure the connector to the main line, and to do this irrespective of small variations in size of the main line. This form of connection has been found to be highly effective in establishing an efficient form of interface between connector and conductor of very low electric resistance across the joint. Despite the fact that this method of connecting a pair of connectors is highly efficient, it is true that, notwithstanding the formation of a practically non-resistant interface between the connectors when crimped

2

onto the conductor, nevertheless some heat is developed particularly at the interface between the main line and the connector, with resulting impairment of the transference of current across the joint and in time this becomes serious, particularly in those cases where the mass of material present and the area of interface are necessarily made large to accommodate the volume of current which the connection is called upon to transmit.

Accordingly, another object of the invention is to provide a form of connector operative between the main supply line and the tap or branch wire which, while capable of transmitting high current values, will at the same time minimize the deleterious effects created by heat formed at the interface.

Broadly, this objective is attained, first, by dividing the necessary mass of conductive material forming the part of the connector at the interface between connector and conductor into two relatively smaller masses, locating them in spaced-apart position on the main line, in fact as far apart as is practicable, and in this way providing two separate and distinct paths for the passage of the current as it is taken off the main line, and, second, to subject the two connectors so formed to the environmental cooling effect of air surrounding each of them.

Separating into two the block-like points where the connector takes current off the main line not only imposes a necessity that the part of the connector which is clamped to the main line as herein featured be of sufficient mass of material at each point to function without possibility of overloading either point, but the spacing apart of the rugged points of contact introduces a necessity to brace the clamps rigidly in their preset related position to resist deformation to which such connectors are subjected while in use, considering that there is also present an ever controlling necessity to reduce the amount of material used in forming the connector as a whole.

Accordingly, the present disclosure features a form of connector which by reason of its configuration has become known as a Y-tap, but actually is a T-tap, and is characterized by three rugged, block-like elements fashioned to be crimped separately onto the main line and tap and which elements are integrally connected in their spaced-apart relation by a web element of less cross section of material than the elements engaging the conductor and yet capable of resisting distorting strains to which such connectors are subjected in service.

The present disclosure in its feature of engaging the main line conductor at spaced-apart points and with the tap depending from a point therebetween give balance to the imposition of strains on the main line by reason of the downward pull resulting from the weight of the tap wire.

Various other objects and advantages of the invention will be in part obvious from an inspection of the accompanying drawings and in part will be more fully set forth in the following particular description of several forms of connectors embodying the invention, and the invention also consists in certain new and novel features of construction and combination of parts hereinafter set forth and claimed.

In the accompanying drawings,

Fig. 1 is a view in side elevation of a tap connector forming a preferred embodiment of the invention and shown connecting a horizontally extending main line conductor with a depending tap;

Fig. 2 is a view largely in plan looking upwardly onto the showing in Fig. 1, viewed from the plane indicated by the line 2—2 of Fig. 1 and showing the post in horizontal hex section on said line;

Fig. 3 is a view partly in side elevation and partly in section of the assembly shown in Figs. 1 and 2 and taken

3

on the line 3—3 of Fig. 1, looking inwardly as indicated by the arrow;

Fig. 4 is a view partly in elevation and partly in section of the right end of the connector shown in Fig. 3 before its post is drilled and with one of the saddle-forming heads in its initial position with the open end of its slot facing downwardly;

Fig. 5 is a detail cross-sectional view of one of the arms connecting its associated head with the post and taken on the line 5—5 of Fig. 1;

Figs. 6 and 7 are views similar, respectively, to Figs. 4 and 3, showing a first modified form of saddle forming headed ends featuring an upwardly-facing slot in Fig. 6, and Fig. 7 showing the slot closed and in section on the line 6—6 of Fig. 1; the Figs. 4 and 6 forms being used in those cases where, as in Fig. 1, it is intended that the slots at the two ends of the connector face one in an upward and the other in a downward relation; and

Fig. 8 is a view similar to Fig. 2 showing another form of connector with downwardly facing saddles similar to those shown in Fig. 4, but equally may be considered to disclose saddles facing as in Fig. 1.

In the drawings and referring, first, to the connector 11 shown in Figs. 1 and 2, there is shown a one-piece solid metal casting of somewhat Y-shape in side elevation designed to be secured permanently to a main line conductor $m-l$ usually extending between widely spaced-apart supports, the nearest one being shown at s in Fig. 1 and the line tends to take a catenary form between its supports, but is straight between the heads hereinafter described. Preferably, the casting is formed of aluminum or copper and having sufficient ductility to be crimped onto the main line and tap and sufficiently soft to be easily drilled. The connector 11 considered as a whole in its initial and final form is symmetrical with its longitudinal medial plane indicated by the line $m-p$ in Figs. 2 and 3.

The connector includes a rugged post 12 initially of cylindrical form and solid with a top face 13 and an exposed bottom face 14. Formed integrally with the top of the post is a crotch portion 15 of a wide-spreading U-form which progressively reduces in width outwardly beyond the crotch as shown in Fig. 4 and forms arms 16 and 17 outstanding in opposite directions from the top of the stem-forming post. The arms are solid and of elliptical form in cross section as shown in Fig. 5. This has the effect of providing downwardly inclined surfaces which tend to shed water which may fall on the connector.

The ends of the arms are enlarged to form rugged blocklike heads 18 and 19, sometimes hereinafter referred to as saddles or hangers. The arms are wide spreading and locate each head equidistantly spaced apart on opposite sides of a vertical coinciding with the axis of the post 12. The heads are spaced apart to form with the vertical an angle of about 60 degrees. These heads when of the hex form herein featured are manufactured as described in copending application Serial No. 293,360, filed June 13, 1952, entitled "Cable Repair Sleeve." The heads are each provided with a slot 20 dimensioned for receiving the main line conductor and as shown in Figs. 4 and 6 the heads are U-shaped in cross section. The slot 20 must be either cast to their right size or machined to their right size as by milling to fit the particular main line conductor for which each is designed to receive. The outer surfaces 21 of each head forms three sides of a hex, and the balance of each head forms two flat, parallel, narrow, bendable fingers or legs 22 designed to complete the hex. In Fig. 4, the open side of the slot faces downwardly, and in Fig. 6 the open side of the slot faces upwardly and otherwise the heads are identical.

It is the intent in this disclosure to use the form of head best suited for the particular job at hand, with both heads employing the downwardly facing slot form of Fig. 4, or with both heads employing the upwardly-facing slot form of Fig. 6. It may be assumed that in Fig. 1 the right head 19 has the downwardly-facing slot and the left head

4

18 has the upwardly-facing slot. In either case the bottom 23 of the slot is semi-cylindrical and is of a size to receive the conductor $m-l$ with a snug running fit. The slots are defined by parallel side faces 24 of the legs or gripping fingers 22 and are tangent to opposite sides of the crotch-forming bottom 23. The legs each terminate at their outer ends in an inwardly inclined bevel face 25 and are fashioned to form the closed joint 25' in Figs. 3 and 7. The inwardly inclined bevel faces 25 at the outer ends of the legs tend to guide the main line $m-l$ into the slots 20 as the connector is lowered on the main line. In the case of the Fig. 4 disclosure the upper inclined side 33 of each of the arms 16 and 17 acts to assist the associated faces 25 in guiding the main line from wherever it may contact the arms above the top face 13 into the associated slot 20.

The post 12 is drilled longitudinally from its outer end face 14 selectively with that diameter of drilling best suited to accommodate that size of tap for which the connector is to be used to form a long cylindrical form of socket 26. The required length of tap line t is provided, one end is inserted in the socket and the post subjected to the deforming action of a crimping tool to give the post the hex form shown in Figs. 1, 2 and 3.

The material forming the casting 11 is distributed so that its center of mass is in the upper part of the post 12, in the medial plane $m-p$ and in transverse alinement with the point marked $c-m$ in Fig. 1. In this way and even in the absence of the tap the connector when hung on the main line will hang therefrom and tend, pendulum-like, to assume gravitationally a steady position in the vertical plane containing the main line $m-l$.

Assuming that the headed ends of the connector are both equipped with the downwardly facing slots of Fig. 4, the connector with the tap t trailing therefrom is lifted towards the main line at the point where the connection is to be made, both headed ends are hooked over the conductor and the connector permitted to fall into place on the line gravitationally. At this time the connector with the downwardly trailing tap t acts as a weighted tail which additionally tends to bring the connector into the vertical plane passing through the axis of the part of the conductor on which the connector hangs. In this way there is little if any torsional strain imposed on the main line incidental to securing the connector thereto. By means of a suitable crimping or compressing tool, in this case with its work face of hex form, squeeze pressure is had in its line of thrust along the medial plane $m-p$, first against one of the heads and then against the other, with the result that in each case the legs of each pair are simultaneously curled inwardly towards each other until the bevel faces 25 contact and thereafter the continued squeeze compacts the head into a permanent crimping engagement with the conductor, incidentally completing the lower half of hexagonal cross sectional form shown in Fig. 3.

In the case where both the heads 18 and 19 have the upwardly-facing form shown in Fig. 6, the connector is lifted into position until the conductor $m-l$ is received in the slots. Then the upstanding side legs at each of the heads are curled inwardly over the conductor rather than under the conductor as previously described. Of course, in this case the connector having been first located in position with the crotch of the slots underlapping and more or less bearing on the conductor, the connector must be held in position manually or otherwise until at least one of the heads has been secured to the conductor. As soon as one of the heads has been so crimped into position on the line the remaining head is similarly crimped on the line and the securing operation is thus completed.

In case a form of connector is used wherein the slot in one of the heads faces upwardly and the slot in the other head faces downwardly as in Fig. 1, the usual practice will be to fish with the head having the downwardly-facing slot until it is hooked over the conductor. This will have the effect of supporting the connector on the conductor and

5

when the other end is lifted toward the main line this will tend to bring the upward-facing slot of the other head more or less into position beneath the part of the conductor which it will subsequently engage. With the conductor finally located in the two slots, first one and then the other head will have its legs unfolded and crimped onto the conductor as previously described.

It is intended that the same crimping tool be used for crimping both the post and the several heads of the connector and by reason of this the cross section of the post and both heads will be the same.

It will be noted that the straight portion p of the conductor $m-l$ which lies stretched between the heads of the connector, and particularly its mid-length part, is spaced from all parts of the connector due to its Y-form and is thus exposed on all sides thereof. This permits the attachment to the portion p of the conductor so held fixedly by the connector herein featured of other and additional forms of tap-off connectors, as suggested by the dotted line showing marked q in Fig. 1.

The modified form of connector in Fig. 8 is of Y-form in side elevation. The post 27 is initially a solid cylinder like the post shown in the lower part of Fig. 4 and is similarly drilled as shown in Fig. 3 to provide a socket 28 for receiving a depending tap line like that shown in Figs. 1 and 2. Projecting upwardly and outwardly from the upper end of the post, somewhat as in Fig. 1, is a pair of flat arms 29 and 30. These arms are somewhat as shown in Fig. 5 except that they are longer in their major axis dimension which extends vertically. These arms extend outwardly from the axis projected upwardly of the post and are disposed in relatively offset planes. Each arm terminates in an enlarged head 31 forming a saddle for receiving a main line as described for the preceding figures with particular reference to the downwardly-facing slots as shown in Fig. 4.

One of the saddle-forming heads 31 projects from the flat part of its associated arm in one lateral direction and the other head similarly projects from the flat side of its associated arm in the opposite lateral direction. Each head is provided with a slot 32 having a downwardly-facing open side as in Fig. 4 with the slots in axial alignment and centered in the longitudinal medial plane of the casting containing the axis of the post.

In this case first one and then the other head is hooked over the main line and hangs in place by its own weight until the compressing tool is brought into operation thereon. The legs of each head are then wrapped inwardly, underlapping the conductor as has been described for the preferred device in the case where both heads are provided with the open bottom slots shown in Fig. 4. It is understood that a transverse sectional view through either of the heads in Fig. 8 will resemble the head of Fig. 4 and that when crimped will resemble the head 19 of Fig. 3.

In both the Fig. 2 and Fig. 8 forms of the connector with their downwardly-facing slots it is suggested that in fishing the connector into position the top face 13 of the post be utilized to catch the portion of main line at a point thereof between where the head connections are to come and that the post be used to elevate the portion of the conductor about to be engaged towards its final position. This lifting of the main line has a tendency to straighten the cable in the part thereof about to be engaged and to relieve tension thereon during the assembly of the connector onto the conductor. With the conductor thus steadied even while in position swinging overhead high in the air, the connector can be rotated slightly about the vertical axis of the post if necessary until the conductor is received in the slots. With the heads located over the conductor and with their slots more or less in line with the conductor, and with the conductor resting on its temporary seat provided by the top of the post, the connector is lowered to receive the

6

main line within the slots. The heads are thus secured to the main line $m-l$ as above indicated.

It is suggested that the post 12 or 27 be drilled, the tap t inserted therein and the drilled post crimped onto one end of the tap while working conveniently on the ground. Then the assembly can be taken up the pole by the workman and hung on the line as above described, thus leaving the operator's hands free to operate the crimping or compressing tool.

By means of the Y-form of connector herein disclosed it is possible to take current off the main line at two widely separated points with each point conveniently accessible for engagement by the crimping tool and each part so crimped is fully exposed for air-cooling and inspection. Exposing the heads in spaced-apart relation on the main line locates them so that the compressing or clamping tool can be applied to the heads so that the tap leg or depending post part of the fitting clears the frame structure of the tool.

As each head is only one-half the total mass of material necessary to provide the requisite area of contact with the main line, the heads are more easily deformed by the available manual force than would be the case if the heads were connected together as one long head. As the connectors are castings the material thereof can be massed and allocated as desired to give structural physical strength where needed, as in the parts designed to be crimped, and to thin out the material in those locations such as in the connecting parts where structural strength is not so positively required. In this way the cost of forming the castings is minimized, particularly in the cost of the expensive conducting material here used.

I claim:

1. A one-piece metallic casting for forming a T tap connector, said casting being of substantially Y-form in side elevation and symmetrical with reference to its longitudinal medial plane and including an initially solid stem with two arms outstanding wide-spreading in opposite directions from one end of the stem and projecting upwardly therefrom, said stem adapted to be drilled longitudinally and axially from its outer end towards the crotch of the Y, selectively with that diameter of drilling best suited to accommodate that size of tap for which the connector is to be used, said arms each provided at their free ends and spaced from the crotch and from each other with enlarged heads of greater cross section of material than the arms and provided with preformed, accurately dimensioned vertically extending slots to form the headed ends U-shaped in cross section, the portion of the connector between each slot and the post forming a solid electric path free of interfaces, said heads being largely exposed for air-cooling, said slots being in axial alignment and fashioned to receive therein a main line conductor with a snug but freely running fit, with the conductor inserted into the slots laterally thereof for the full length of each slot while maintaining the continuity of the conductor and the sides of the U-shaped heads forming the slot being sufficiently ductile to permit the sides to be folded in towards each other to surround completely the portion of the conductor engaged thereby and to crimp the main line permanently and under squeeze pressure to the connector at two widely spaced-apart and thus separated points.

2. The casting defined in claim 1 wherein the open sides of the slots face in the same downward direction and are thus exposed for their full width to receive the main line when the headed ends are hooked over the line and seated in the slots with the stem depending from the line as a weighted tail tending to hold the casting gravitationally in an upright position before it is crimped onto the main line.

3. The combination with a main line suspended to assume a catenary form, a one piece tap connector hung from the line in spaced relation to its ends to maintain

7

the continuity of the line and a tap wire depending from the connector and functioning as a weighted tail, said connector being of substantially Y-form in side elevation considered parallel to the main line and including an up-standing post and two wide-spreading arms extending in opposite directions from the upper end of the post, said post provided in its lower end with a socket in which the upper end of the tap wire is secured and said arms provided at their outer ends with massive enlargements in widely spaced-apart axially aligned relation forming rigid U-shaped saddles provided therein with slots disposed in axial alignment and in the crotch portion of which saddles the main line is received, and the sides of the saddles outlining the slots below being thin crotch portions flexible and fashioned to have their free ends bent inwardly towards each other to crimp the connector in position permanently secured to, suspended from the main line and completely encircling the same at two spaced-apart points on the main line, leaving the portion of the main line between the saddles spaced above the post and exposed for engagement therewith of other taps.

4. A one-piece metallic casting forming a connector for connecting a tap wire electrically to a main line at any point along the same without cutting the main line, said casting being of substantially Y-form and including a vertically extending post and two widely spreading arms projecting in opposite directions upwardly and outwardly from the upper end of the post, said arms at their outer ends forming massive saddles U-shaped in cross section prior to being secured to the main line and each provided therein with an open-sided slot with at least one of the slots facing downwardly, said slots being in alignment and adapted to receive the main line therein through the open sides of the slots and the center of mass of the connector being in the post and below the saddles whereby when the connector is hung with its downwardly-facing slot hooked over the main line the post will extend vertically, and means carried by the post for securing a tap wire thereto in position to cause the tap wire to act as a weighted tail and tend to keep the connector in the vertical plane containing the conductor before the connector is secured to the conductor and the sides of the saddles outlining the slots being of relatively narrow width with their free ends forming inwardly inclined guide faces and said sides forming fingers sufficiently ductile to permit them to be bent inwardly each over its associated slot and with their inclined faces in end-to-end contact to form the sides circular in cross section and to condense therein the portion of the main line crimped thereby.

5. A one-piece metallic casting for forming a tap connector, comprising an upstanding solid post and a pair of outstanding arms extending integrally from one end of the post, said post adapted to be drilled into the same axially thereof through its lower end to provide a socket of proper size to accommodate the particular size of the tap with which the connector is to be used, the outer ends of the arms formed with increase in cross section of material to form massive hangers of substantially inverted U-form disposed in alignment and with their open sides facing downwardly and the hangers designed to be hung onto a main line and shiftable along the main line as a support into the position where the connector is to be secured, and the sides of the hangers forming narrow bendable fingers sufficiently ductile to permit them to be folded inwardly towards each other about the main line as a mandrel to retain the main line therein and permanently secured thereto at the point selected to connect with the tap, the part of the casting between the solid post and each of the bendable fingers forming a solid electric path free of interfaces and with the open sides of the hangers facing said solid part of the casting in position to receive the main line when guided into the same by said solid part.

8

6. A one-piece casting including an initially solid up-standing post, a pair of arms for the most part flat, projecting upwardly and integrally from the upper end of the post and extending outwardly from the axis projected of the post in parallel and relatively offset planes, each arm terminating at its free end in a head of enlarged cross section of material forming a rigid saddle of inverted U-form, one saddle projecting from the flat part of its associated arm in one lateral direction and the other saddle similarly projecting from the flat part of its associated arm in the opposite lateral direction, each saddle provided with a slot formed therein and having a downwardly facing open side and with the slots rigidly fixed in axial alignment and in the longitudinal medial plane of the casting containing the axis of the post.

7. A one-piece casting formed of conductive material for forming a connector to be hung from a main line to connect the same electrically with a depending tap, said casting including a post whose upper and lower ends are exposed, the post adapted to be drilled axially through its lower end to provide a socket for receiving the tap wire and the upper end providing a temporary seat for the main line for use in the act of securing the main line to the connector, a pair of arms projecting in opposite directions from the upper portion of opposite sides of the post and contained in parallel planes offset on opposite sides of the axis of the post, each arm provided at its free end with a saddle for engaging the main line and provided with a downwardly-facing slot for receiving the main line as the casting is lowered to receive the main line from its temporary seat at the top of the post, said slots being in axial alignment and contained in the plane of the axis of the post, and the part of the saddle outlining opposite sides of the slots being sufficiently ductile to be bendable inwardly about the main line to secure the main line circularly shaped in the spaced-apart saddles.

8. A one-piece article of manufacture formed of a highly conductive metal for forming a T-tap connector, said article being of Y-form in side elevation with its stem forming a depending post for attaching a tap thereto and its upper portion forming a pair of wide spreading arms with a crotch portion connecting their inner ends and with the crotch portion being integral with the post and arms, each arm provided at its free outer end with a saddle-forming head for suspending the connector from a main line at two spaced-apart points thereon, the upper end of each head forming exteriorly one-half of a hexagon in cross-section and interiorly the crotch portion of a downwardly-facing slot, and the balance of each head forming a pair of bendable legs, the arms merging at their outer ends integrally into one of the legs of its associated saddle and each providing a guide surface for directing the main line into its associated slot, the free end of each leg provided with an inwardly inclined guide face, the portion of the article between each saddle and the post forming a solid electric path and thus free of interfaces, said heads being exteriorly exposed for air cooling and the legs exposed for the engagement therewith of a crimping tool for crimping the heads onto the main line to cause the inclined faces to contact in end-to-end relation and to force the parts of the main line engaged thereby into the crotch of the slot to secure the saddles circularly to the main line.

9. The article defined in claim 8, wherein the axis of the post and the axis of the two slots are in the vertical medial plane of the article, the center of mass of the article is in the stem and close to the crotch portion, and the two heads each form an angle of about 60 degrees with a line passing through the stem of the Y.

10. The article defined in claim 9, wherein the arms are elliptical in cross section, extend upwardly and out-

9

wardly from the crotch portion at the post, and each reducing in cross section of material from that at the post to that at the leg into which it merges.

References Cited in the file of this patent

UNITED STATES PATENTS		
862,082	Lewis -----	July 30, 1907
1,070,948	Dodd -----	Aug. 19, 1913
1,225,366	Schoenman -----	May 8, 1917
2,021,399	Becker -----	Nov. 19, 1935

2,307,216
2,397,390
2,462,247
2,555,074
2,604,341
2,604,508

5

10

10

Graham -----	Jan. 5, 1943
Wadsworth -----	Mar. 26, 1946
Wright -----	Feb. 22, 1949
Bergan -----	May 29, 1951
Bergan -----	July 22, 1952
Bergan -----	July 22, 1952

FOREIGN PATENTS

Great Britain -----	of 1899
France -----	May 3, 1943