

(19)
(12)

(KR)
(B1)

(51) 。 Int. Cl. ⁷
G11C 11/40

(45)
(11)
(24)

2002 07 05
10 - 0343139
2002 06 22

(21) 10 - 1999 - 0051875
(22) 1999 11 22

(65) 2001 - 0047582
(43) 2001 06 15

(73)

3 416

(72)

24 - 1

(74)

:

(54)

가

1

2

1

1

2 1
 3 2
 4 1
 5
 6 5
 7
 8 7
 9 7
 10 7
 11
 12 11

가

가
skew)가

(synchronous DRAM) (clock)
(data valid window)

(

(PCB; printed circuit board)

(memory controller)

(device)

가

(Tclk)

(Rclk)

가

/

(

master clock) (Tclk) (Rclk) , 가

(bidirectional data strobe) , I
EEE (IEEE JOURNAL OF SOLID STATE CIRCUITS, VOL 33. NO. 11.NOVEMBER 1998)
(data strobe signal) 가
(master clock)
가 . ,

(Tclk) (Rclk) 가 ,

1

2

1

2

가 가 , 가

가 , 1 , 1

가 , 2 가 ,

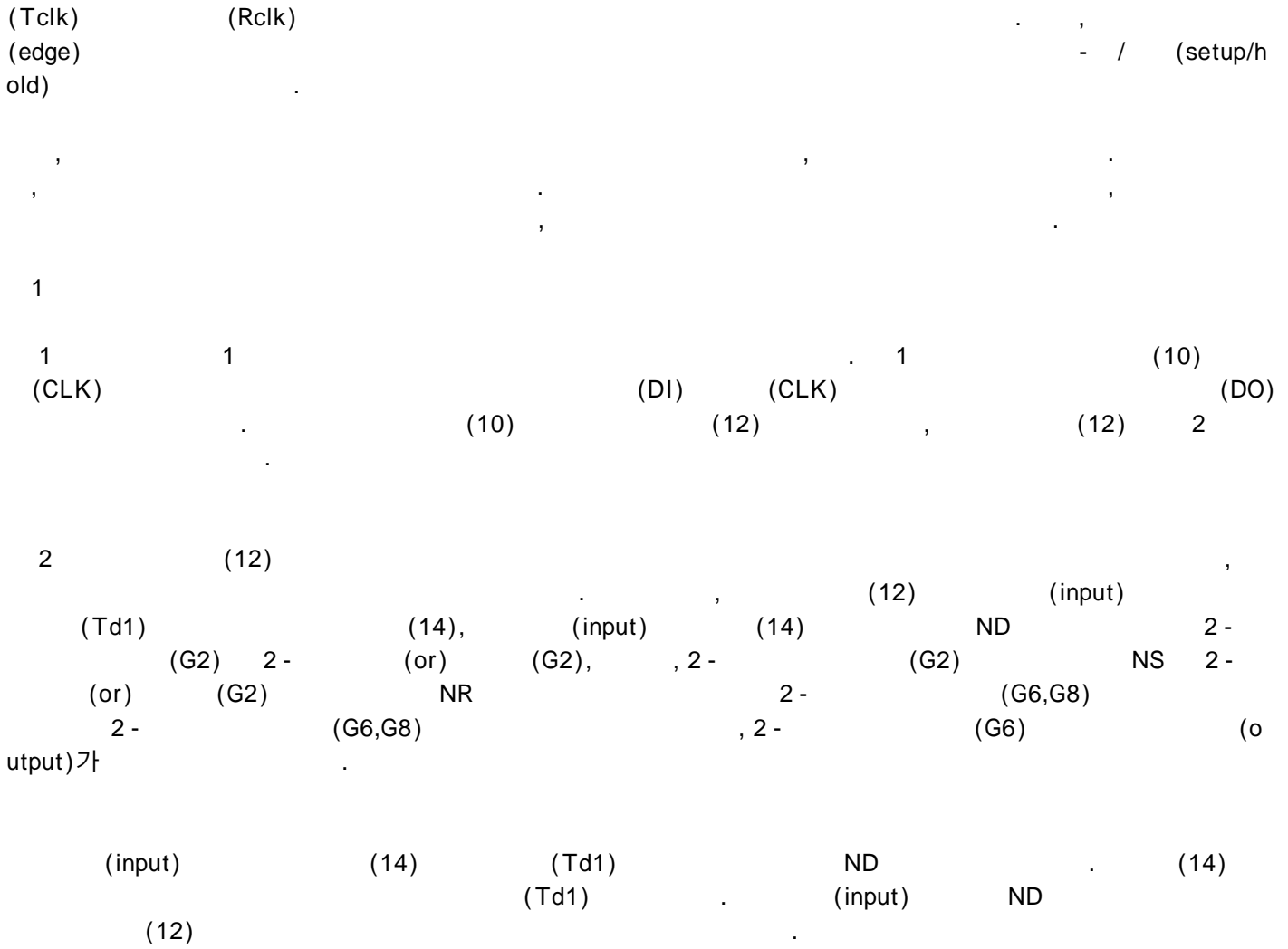

[1]

input	ND	NS	NR	output
0	0	1	0	1
0	1	1	1	
1	0	1	1	
1	1	0	1	1



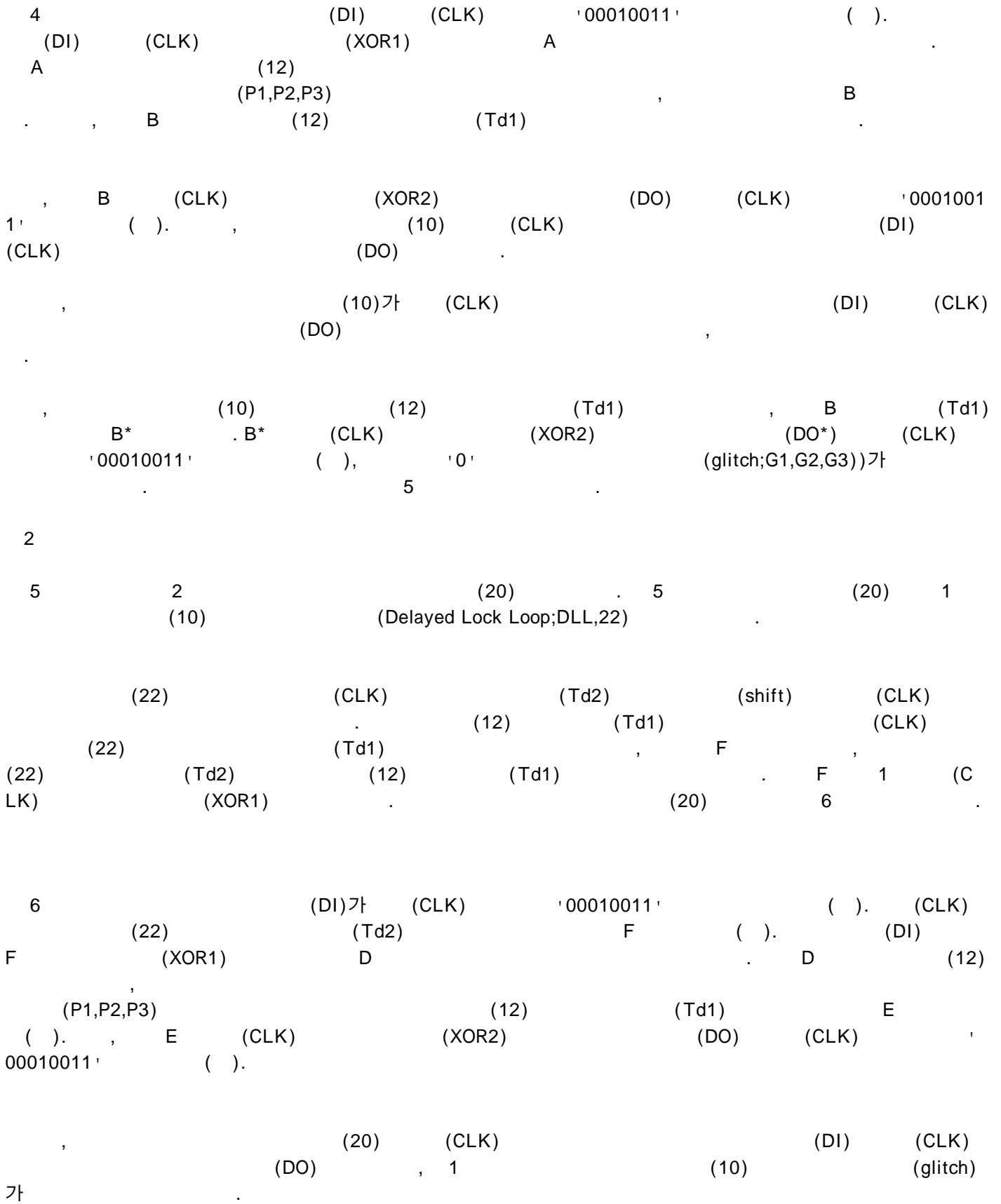

7 (CLK) 5 (12) 3 (DI)가 (30) (clk) (width) 1/2(= (12) (CLK) 1/4) (30)

7 (32), (31) (30) (DI) (31), (CLK) (XOR1),
 H (36) (VCON) G H 2- (Td3) 가 (33)
 (33), H /2, (CLK) 1/4 (Tclk/4) (34), 가 (35)
 (34) I J (XOR1) L (35), (35) K
 (36), (37), (37) M I 2- VCON
 (XOR2) (30) 8

8 (CLK) (32) H H 가 (33) (3)
 (36) (VCON) (Td3) I (),
 4) (CLK) 1/4 (Tclk/4) J (). I J
 (35) (35) 9 9 (35) D- (D - flip flo
 p) (35) 8 K

(VCON) K 9 (integrator) (36) (36)
 () K ()
 (VCON) K (36) () (36)
 (VCON) (36) (36) (VCON) 8 (36)

7 8 ,가 (33) (CLK) , H I (36)
 (36) (VCON) (Td3) ,가 (33) (CLK)
 (VCON) 1/4(Tclk/4) (Td3)

(DI) (31) G (CLK) '11
 010110 (XOR1) G H (VCON) L
 (37) L (input) (36) (VCON)
 (37) (Td4) ()

(37) 2 (12) (14) (Td1) 7
 (Td4) (36) (VCON) (Td4) (37)
 10

10 2 (12) (14) 가 (114) . , 가
 (114) (input) , 7 L ND , (TN1) 가 (VCON) (36) (VCO
 N) , (36) (TN1) L ND . (36)
 , (VCON) (Td4) (VCON) (Td4) (36) (36)
 (VCON) (Td4) . , (37) (Td4) (CLK)
 ¼(Tclk/4) .

, 7 (37) L , (36) (VCON) 가
 (P1,P2,P3) (Td4) , (CLK) ¼(Tclk/4) .

, M I (XOR2) (DO) (CLK) (e
 dge) (30) (CLK) '11010110' (DI) (). (CLK)
 (DO) (CLK) (DO) - / (setup/hold) (30)

11
 (40) , (41,42,43)
 (44) . (41,42,43) (44)
 (46) (CLK) DQ .
 time) Tf1 (44) 가 가 (43) L1 (flight
 Tf2 , (44) 가 (41) L2 (CLK)
 Tf1 Tf1+Tf2 (41,42,43) .

12 , (46) (44) (CLK_MC) 12 . (41,4
 2,43) (CLK_M) 가 , (44) DQ
 (DQ_MC)가 (DQ_MC) (41,42,43) (CLK_MC) (41,42,43) DQ
 (DQ_M) (DQ_MC) Tf1 Tf1+Tf2 .
 DQ (DQ_M) (41,42,43)
 (CLK_M) , (CLK_M) (41,42,43) (4
 1,42,43) DQ (IDQ) , (41,42,43) DQ (IDQ) 가 .

가 가 가 , .

lk) . (Tclk) (Rc
 , (edge) (DO)
 - / (setup/hold) .

(57)

1.

1

;

;

2

,

,

;

;

;

2.

3.

,

;

1

;

;

2

,

,

;
;
;

4.

,

;

가 가 ;

가 ;

가

;

1 ;

,

가

;

가 2 ,

,

5.

6.

4 ,

가 , D-

7.

4 ,

8.

4

가

가

가

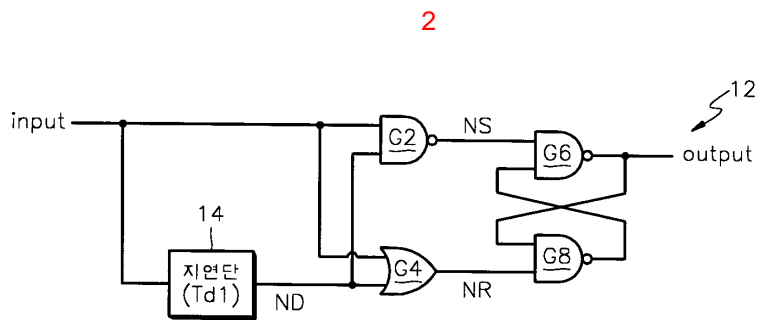
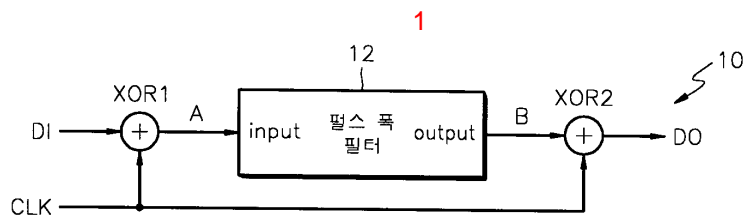

3

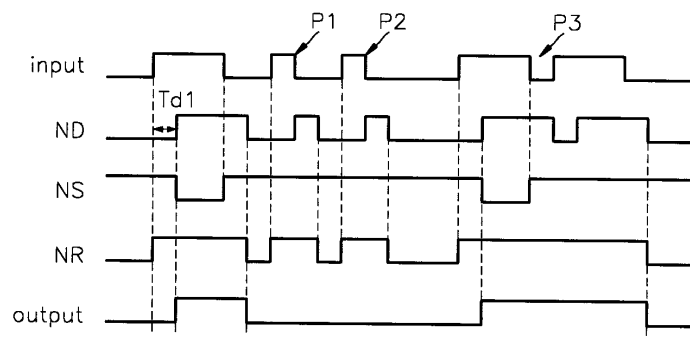

4

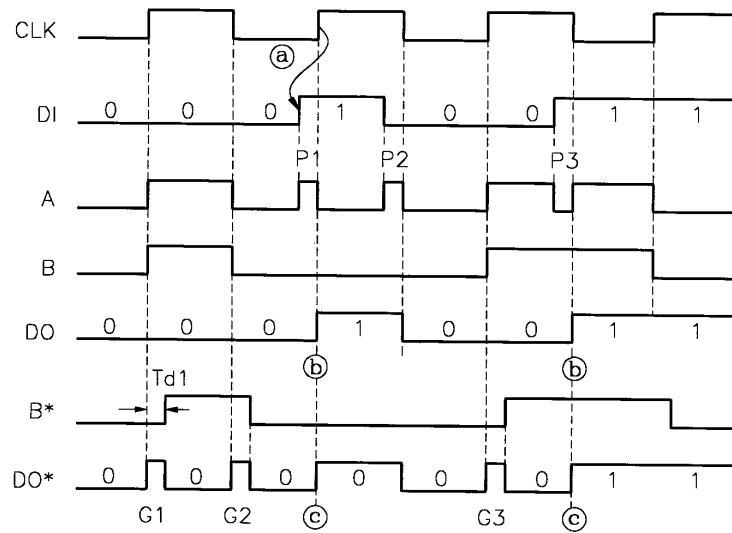

5

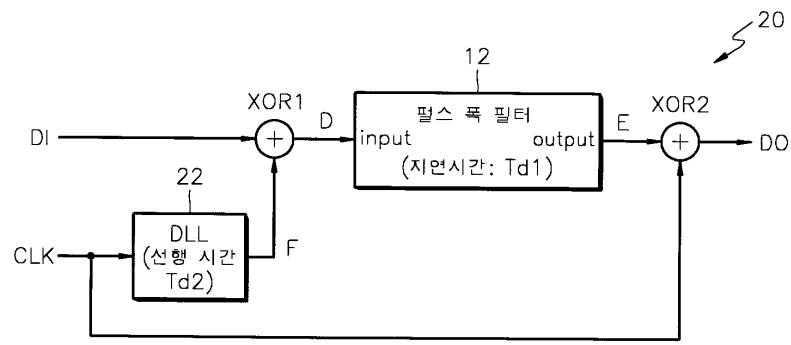

6

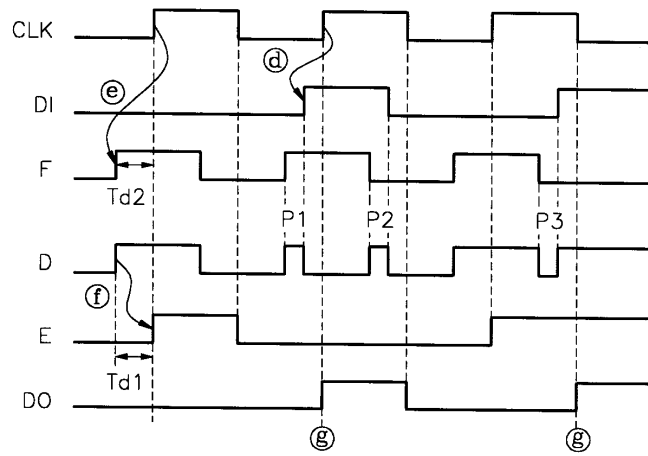

7

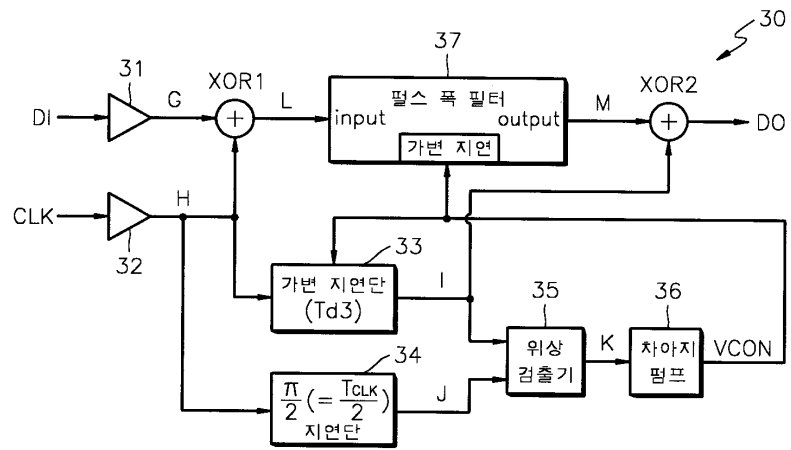

8

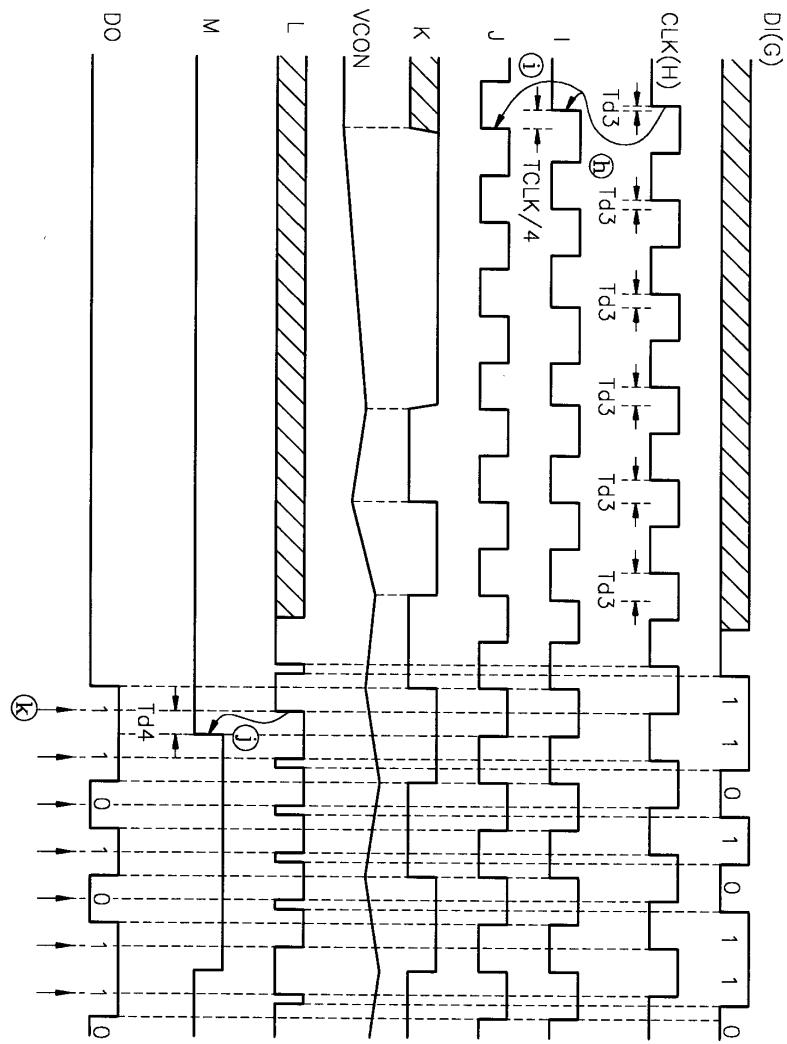

9

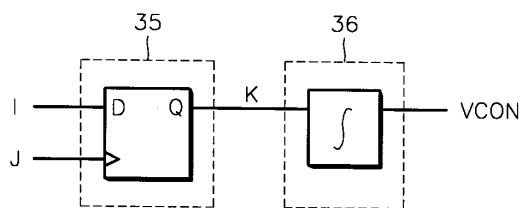

10

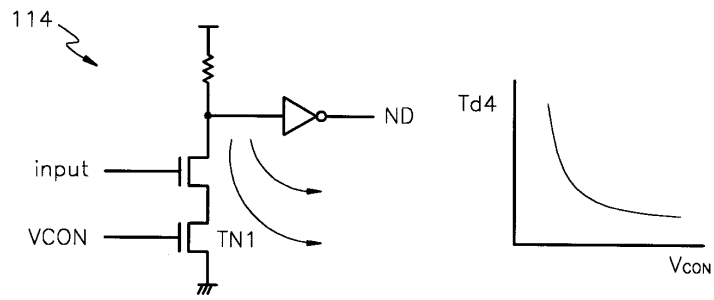

11

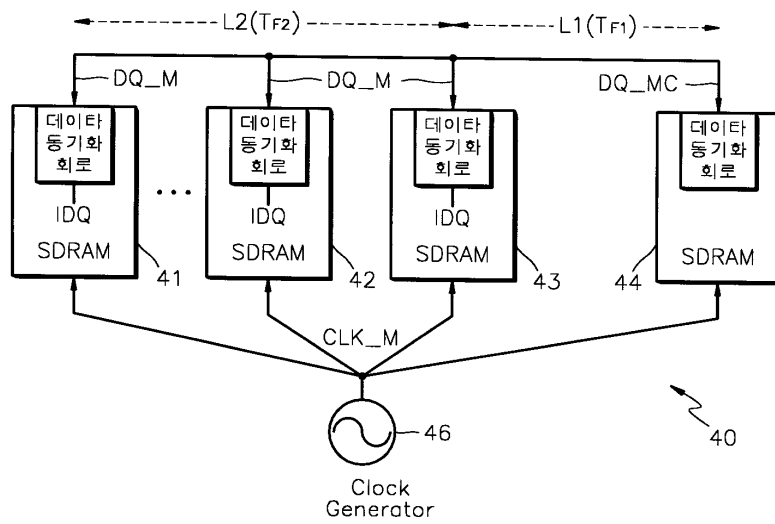

12

