



(11) **EP 1 726 890 B1**

(12) **EUROPEAN PATENT SPECIFICATION**

(45) Date of publication and mention of the grant of the patent:
29.10.2008 Bulletin 2008/44

(51) Int Cl.:
F24F 1/00^(2006.01) F24F 13/20^(2006.01)

(21) Application number: **06380106.2**

(22) Date of filing: **09.05.2006**

(54) **Indoor unit of an air conditioner**

Innenraumeinheit einer Klimaanlage

Unité d'intérieur d'un dispositif de conditionnement d'air

(84) Designated Contracting States:
AT BE BG CH CY CZ DE DK EE ES FI FR GB GR HU IE IS IT LI LT LU LV MC NL PL PT RO SE SI SK TR

(30) Priority: **10.05.2005 ES 200501112**

(43) Date of publication of application:
29.11.2006 Bulletin 2006/48

(73) Proprietor: **Universitat Politecnica de Catalunya 08028 Barcelona (ES)**

(72) Inventor: **Nacenta Anmella, Jose Maria 08028 Barcelona (ES)**

(74) Representative: **SUGRANES - VERDONCES - FERREGÜELA**
304 Calle Provenza
08008 Barcelona (ES)

(56) References cited:
EP-A- 1 686 324 US-A- 4 367 636
US-A- 5 769 709 US-A- 5 823 002

- **PATENT ABSTRACTS OF JAPAN vol. 007, no. 159 (M-228), 13 July 1983 (1983-07-13) & JP 58 066737 A (HITACHI SEISAKUSHO KK), 21 April 1983 (1983-04-21)**

EP 1 726 890 B1

Note: Within nine months of the publication of the mention of the grant of the European patent in the European Patent Bulletin, any person may give notice to the European Patent Office of opposition to that patent, in accordance with the Implementing Regulations. Notice of opposition shall not be deemed to have been filed until the opposition fee has been paid. (Art. 99(1) European Patent Convention).

Description**Technical field of the invention**

[0001] The invention relates to an indoor unit of an air conditioner of the type that consists of a hollow casing with vents for the inlet and outlet of air, respectively, being housed therein at least one heat exchanger and a fan that inhales air, through the inlet vent, from the comfort area of a room to the surfaces of the heat exchanger and returns it, through the outlet vent, to said comfort area.

Background of the invention

[0002] The known indoor units of air conditioners consist of an outer casing, in the form of a cabinet, with an air inlet grille or orifice situated preferably, in apparatus to be installed in a horizontal or vertical position, on the lower part and an air outlet grille or orifice situated on the front part of the casing. Said units also comprise a heat exchanger generally consisting, in cooling apparatus, of an evaporator that cools the air that enters the casing through the inlet grille using the evaporation heat of a refrigerant. A fan housed inside the casing is responsible for inhaling the air from the room, directing it towards the heat exchanger of the indoor unit and expelling it towards the outside through the outlet grille or through tubes.

[0003] An example of an indoor unit of an air conditioner is disclosed in document WO 3033965. The casing of the unit has a front orifice or a grille that extends horizontally, behind which a tangential fan is positioned, inside the casing, which inhales and expels the air in a tangential direction in relation to its axis of rotation. Until now, this type of fan, with an axis of rotation parallel to the inlet grille or orifice, has been used because the fan motor can be housed inside the casing at one of the ends of the fan, thus increasing the length of the casing to a greater or lesser extent whilst avoiding having to increase the thickness thereof. In this type of unit the thickness of the casing is determined by the diameter of the fan wheel, which, to achieve an optimum airflow, must have a minimum size. As has been mentioned above, this minimum size conditions the thickness of the casing; the greater the airflow, the thicker the casing.

[0004] The use of centrifugal fans, positioned inside the casing in such a way that their axis of rotation is perpendicular to the largest faces of said casing, partly solves the aforementioned problems. An example of such a construction is drawn in document US 5823002.

[0005] Despite the fact that the diameter of the fan wheel does not condition the thickness of the casing, the size of the drive motor of said fans does condition said thickness. This type of fan is often used in units to be installed horizontally on the ceilings of rooms requiring air conditioning. In this type of installations the thickness of the unit is not particularly relevant as the unit is usually built into the false ceiling of the room and the formwork of the floor above.

[0006] There is therefore a need for an indoor air-conditioning unit that is thinner than known units, without this entailing a reduction in the flow of inhaled air, ensuring an optimum cooling capacity of the air conditioner.

Explanation of the invention

[0007] The indoor unit of an air conditioner that is the object of the invention overcomes the aforementioned problems. Said unit consists of an essentially parallelepipedic straight rectangular hollow casing with vents for the inlet and outlet of air, respectively, being housed therein at least one filter element, at least one heat exchanger and a centrifugal fan that inhales air, through the inlet vent, from the comfort area of a room to the surfaces of the heat exchanger and returns it, through the outlet vent, to said comfort area.

[0008] The unit is essentially characterised in that it comprises a separator that divides the casing into two transversal cavities, one inlet cavity and one outlet cavity, with an opening for the air to pass from one cavity to the other, the fan being positioned in said opening of the separator, in such a way that its axis of rotation is essentially perpendicular to the largest faces of the casing, said opening constituting the entrance to the air intake of the fan, and in that the heat exchanger is situated on one side or other of the fan, always outside the projection, in an axial direction, of the air intake thereof.

[0009] According to another characteristic of the invention, the relationship between the diameter (D) of the fan wheel and the outlet height (h) of the fan blades follows the ratio: $D/h \geq 5.5$.

[0010] According to another characteristic of the invention, the unit is characterised in that the drive motor of the fan is housed therein, and in that the stator of said motor is housed inside a casing situated in the air intake of the fan, fastened to one of the largest faces of the hollow casing of the indoor unit.

[0011] According to another characteristic of the invention, the fan wheel comprises a flat annulus or flat circle that joins the blades of said wheel, which project from the air intake towards the ends of the fan, the annulus being joined to the rotor of the drive motor of the fan, which is an external rotor motor, and in that the stator of said motor is fastened, by supports, to the face of the casing adjacent to the annulus of the fan wheel.

Brief description of the drawings

[0012] In the attached drawings an embodiment of the indoor unit of an air conditioner according to the invention is illustrated by means of a non-limiting example. In said drawings:

Fig. 1 is a view of the longitudinal section of an indoor unit according to the invention;
Figs. 2a, 2b and 2c each show cross-section views of the separator and the fan corresponding to three

variants of an indoor unit according to the invention;
and

Fig. 3 shows a schematic perspective view of the indoor unit shown in Fig. 1.

Detailed description of the drawings

[0013] The indoor unit 1 of the air conditioner shown by way of an example in Fig. 1 is formed in a known way by a parallelepipedic straight rectangular hollow casing 2 with vents for the inlet 18 and outlet 19 of air, respectively, being housed therein two filter elements 3, that cover said air inlet and outlet vents; a heat exchanger 4; and a centrifugal fan 5 that inhales air, through the inlet vent 18, from the comfort area of a room to the surfaces of the heat exchanger 4 and returns it, through the outlet vent 19, to said comfort area.

[0014] As is shown in Figs. 1 and 3, the indoor unit 1 comprises a separator 6 that divides the casing into two transversal cavities, one inlet cavity 1 a and one outlet cavity 1 b. The separator has an opening 11 (see Fig. 3) for the air to pass from the inlet cavity 1 a to the outlet cavity 1 b, always through the centrifugal fan 5 positioned for this purpose on one side of said opening in the separator, its axis of rotation being perpendicular to the largest faces 17 and 17' of the casing 2, said opening 11 constituting the fan's air intake 7. In the example shown in Figs. 1 and 3 the heat exchanger 4 is situated in the inlet cavity 1 a of the casing 2, outside the projection, in an axial direction, of the fan's air intake 7.

[0015] The air flow through the inside of the casing 2 follows an axial direction at the inlet of the fan 5 and flows perpendicular to the axis thereof at the outlet of the fan 5, the inlet direction and outlet direction of the air thus forming a right angle.

[0016] The fan 5 is preferably of the type fitted with blades 9 facing forwards (action) or backwards (reaction). Fans fitted with blades facing forwards have a larger number of blades but generate little noise. For the same speed of rotation, this type of fan achieves the same airflow with a smaller fan compared to other types of fan. Fans fitted with blades facing backwards offer better performance than the former type because the old flat blades can be replaced by the latest designs with an aerodynamic profile, making it possible to reach performances of between 75 and 80% although, for the same speed of rotation and number of blades, their mass flow rate and their pressure are lower than fans of the type that have blades facing forwards.

[0017] In general, by using this type of fans it is not necessary to reach high speeds of rotation to achieve sufficient flow and force of air. In this embodiment the fan works at few revolutions per minute; to be specific, with a motor with 6 or more poles it can work at up to 950 revolutions per minute.

[0018] In order to achieve the optimum flow with the minimum space in which to locate the drive motor of the fan 5, the relationship between the diameter D of the

wheel 8 of the fan 5 and the outlet height h of the fan blades 9 follows the expression $D/h \geq 5.5$. It is thus possible to achieve, as can be seen in Fig. 3, a considerable reduction in the thickness of the casing 2 compared to the current thickness of known indoor units, keeping the same technical features as regards cooling capacity, airflow, available pressure, electrical consumption and noise level. This reduction is actually due to not only the dimensions of the fan 5 but also the innovative location of the drive motor 12 inside the air intake 7 of the fan 5. With these characteristics it is possible to reduce the maximum thickness of the casing of conventional indoor units of air conditioners by between 30 and 40%.

[0019] In effect, as can be observed in detail in Figs. 2 and 3, the stator 10 of the drive motor 12 is housed inside a casing 13 situated in the air intake 7 of the fan 5, fastened to one of the largest faces of the hollow casing 2 of the indoor unit. With the motor thus located, the thickness of the casing 2 adapts to measurements very similar to those of the drive motor 12, which in turn guarantees an airflow of the proportions between the diameter and the outlet height of the blades of the fan described above.

[0020] As can be observed in Figs. 2a and 2b the wheel 8 of the fan 5 comprises a flat annulus 15 that joins the blades 9 of said wheel, which project from the annulus towards the air intake 7, said annulus 15 being joined to the rotor 14 of the drive motor 12 of the fan 5. In the example in Fig. 2b, the drive motor 12 is an internal rotor motor, and the stator 10 of said motor is fastened, by corresponding supports 16', to the face 17' opposite the face 17 of the casing 2 that is adjacent to the annulus 15 of the fan wheel.

[0021] By way of an alternative, in the example shown in Fig. 2a the drive motor 12 is an external rotor motor, and the stator 10 of said motor is fastened, by supports 16, to the face 17 of the casing 2 adjacent to the annulus 15 of the wheel 8 of the fan 5. This has an advantage over the previous variant, in that the supports 16 do not have to be adapted to the thickness of the casing 2.

[0022] Fig. 2c shows another variant of an indoor unit of an air conditioner according to the invention, and more specifically of the separator 6 and the area in which the wheel 8 is located. In said variant it can be observed that the face 17 of the casing 2 is not flat and that, unlike the variants in Figs. 2a and 2b, it has a recess 20 that determines a housing wherein the drive motor 12 of the fan 5 is located. Said motor 12 is firmly attached to the casing by means of supports 16' and it also has a second set of wall fastening supports 21 for the attachment thereof to the walls of the room, preferably to the wall adjacent to the ceiling.

[0023] In the example shown in Fig. 2c, the recess 20 takes the form of an inverted dome and has a hole through which the axis of rotation of the fan 5, driven by the rotor 14 of the drive motor 12 is inserted into the casing 2 to thereby transmit the rotational movement to the wheel 8 of the fan 5. Advantageously, according to this constructive variant it is not necessary to dismantle the casing 2

to perform any maintenance or repair work on the drive motor 12.

[0024] Unlike known indoor units, wherein the fan 5 has its own casing that encloses the fan wheel and forms the fan's air intake, in the indoor unit according to the invention it is the separator 6 that performs said function. As can be observed in Fig. 1, the opening 11 in the separator 6 has a section, like a funnel, that widens in the direction of the airflow. In said figure, the walls that constitute the air intake of the fan 5, which form part of the separator 6, are of a concave generatrix whilst the upper profile of the blade 9 is straight. Although not shown in the drawings, it should be understood that the upper profile of the blades 9 can be curved and that the walls that constitute the air intake of the fan 5 can have a straight generatrix or can have a curvature that is complementary to that of the upper profile of the blades 9.

[0025] In Figs. 2a and 2b, by way of an alternative, the opening 11 in the separator 6 does not have a collar to accompany the air inhaled by the fan 5 towards the blades 9.

[0026] On the outlet side, the separator 6 can have a rounded form to aid the flow of air as it leaves the fan 5, towards the outlet vent 19, similar to spiral-shaped casings.

[0027] Naturally, the air inlet 18 and outlet 19 vents can be situated on the lateral faces or on the front face of the casing 2. As regards the heat exchanger 4, it is disposed at an angle to the largest faces 17 and 17' of the casing 2 of the indoor unit 1, thus maximising the surface area for contact with the air.

[0028] With these characteristics, the indoor unit 1 of the air conditioner that is the object of the invention can either be installed in a horizontal position, suspended from the ceiling of the room to be air conditioned, or in a vertical position, resting against one of the walls of said room, occupying a minimum space thanks to the reduction in the thickness of the casing 2.

Claims

1. Indoor unit (1) of an air conditioner of the type that consist of an essentially parallelepipedic straight rectangular hollow casing (2) with vents for the inlet (18) and outlet (19) of air, respectively, being housed therein at least one filter element (3), at least one heat exchanger (4) and a centrifugal fan (5) that inhales air, through the inlet vent, from the comfort area of a room to the surfaces of the heat exchanger and returns it, through the outlet vent, to said comfort area, the indoor unit comprising a separator (6) that divides the casing into two transversal cavities, one inlet cavity (1a) and one outlet cavity (1 b), with an opening (11) for the air to pass from one cavity to the other; the fan being positioned in said opening of the separator, in such a way that its axis of rotation is essentially perpendicular to the largest faces of

the casing, said opening constituting the air intake (7) of the fan; and the heat exchanger being situated on one side or other of the fan, always outside the projection, in an axial direction, of the air intake thereof, **characterised**

- **in that** the relationship between the diameter (D) of the fan wheel (8) and the outlet height (h) of the fan blades (9) follows the ratio

$$D/h \geq 5.5$$

- and **in that** the stator (10) of the drive motor (12) of the fan is housed inside a casing (13) situated in the air intake (7) of the fan, fastened to one of the largest faces of the hollow casing (2) of the indoor unit.

2. Indoor unit (1) according to claim 1, **characterised in that** the fan wheel (8) comprises a flat annulus (15) that joins the blades (9) of said wheel, which project from the air intake towards the ends of the fan (7), the annulus being joined to the rotor (14) of the drive motor (12) of the fan (5), which is an external rotor motor, and **in that** the stator (10) of said motor is fastened to the face (17) of the casing (2) adjacent to the annulus of the fan wheel by supports (16).

Patentansprüche

1. Inneneinheit (1) eines Klimageräts von der Art, die aus einem im Wesentlichen parallelepipedischen geraden rechteckigen hohlen Gehäuse (2) mit Lüftungsöffnungen für den Einlass (18) bzw. Auslass (19) von Luft besteht, worin wenigstens ein Filterelement (3), wenigstens ein Wärmetauscher (4) und ein Zentrifugalventilator (5) angeordnet sind, der durch die Einlassöffnung Luft aus dem Komfortbereich eines Raums zu den Oberflächen des Wärmetauschers ansaugt und sie durch die Auslassöffnung wieder an den Komfortbereich abgibt, wobei die Inneneinheit ein Trennelement (6) umfasst, welches das Gehäuse in zwei transversale Hohlräume, einen Einlasshohlraum (1a) und einen Auslasshohlraum (1 b), unterteilt, mit einer Öffnung (11) für den Übertritt der Luft von einem Hohlraum in den anderen; wobei der Ventilator derart in dieser Öffnung des Trennelements angeordnet ist, dass seine Drehachse im Wesentlichen senkrecht zu den größten Flächen des Gehäuses ist, wobei diese Öffnung die Luftansaugung (7) des Ventilators bildet; und wobei sich der Wärmetauscher auf der einen oder anderen Seite des Ventilators immer außerhalb der Projektion, in axialer Richtung, der Luftansaugung desselben befindet, **dadurch gekennzeichnet,**

- **dass** die Beziehung zwischen dem Durchmesser (D) des Ventilatorrades (8) und der Auslasshöhe (h) der Ventilatorflügel (9) dem Verhältnis:

$$D/h \geq 5,5$$

folgt

- und **dass** der Stator (10) des Antriebsmotors (12) des Ventilators in einem Gehäuse (13) angeordnet ist, das sich in der Luftansaugung (7) des Ventilators befindet, und an einer der größten Flächen des hohlen Gehäuses (2) der Inneneinheit befestigt ist.

2. Inneneinheit (1) nach Anspruch 1, **dadurch gekennzeichnet, dass** das Ventilatorrad (8) einen flachen Kranz (15) umfasst, der die Flügel (9) des Rades verbindet, die von der Luftansaugung zu den Enden des Ventilators (7) ragen, wobei der Kranz mit dem Rotor (14) des Antriebsmotors (12) des Ventilators (5) verbunden ist, der ein Motor mit Außenrotor ist, und dass der Stator (10) des Motors mittels Halterungen (16) an der Fläche (17) des Gehäuses (2), welche an den Kranz des Ventilatorrades angrenzt, befestigt ist.

Revendications

1. Unité d'intérieur (1) d'un conditionneur d'air du type consistant en une carcasse (2) creuse rectangulaire droite essentiellement parallélépipédique avec des événements pour l'entrée (18) et la sortie (19) d'air, respectivement, au moins un élément de filtre (3) étant logé en son sein, au moins un échangeur de chaleur (4) et un ventilateur centrifuge (5), qui inhale l'air, à travers l'évent d'entrée, à partir de l'aire de confort d'une salle jusqu'aux surfaces de l'échangeur de chaleur et le renvoie, à travers l'évent de sortie, à ladite aire de confort, l'unité d'intérieur comprenant un séparateur (6) qui divise la carcasse en deux cavités transversales, une cavité d'entrée (1a) et une cavité de sortie (1 b), avec une ouverture (11) pour que l'air passe d'une cavité à l'autre ; le ventilateur étant positionné dans ladite ouverture du séparateur, de telle manière que son axe de rotation est essentiellement perpendiculaire aux faces les plus grandes de la carcasse, ladite ouverture constituant l'admission d'air (7) du ventilateur ; et l'échangeur de chaleur étant situé sur un ou l'autre côté du ventilateur, toujours en dehors de la projection, dans la direction axiale, de son admission d'air, **caractérisé**

- **en ce que** le rapport entre le diamètre (D) de la roue de ventilateur (8) et la hauteur de sortie

(h) des aubes de ventilateur (9) suit la relation

$$D/h \geq 5,5$$

- et **en ce que** le stator (10) du moteur d'entraînement (12) du ventilateur est logé au sein d'une carcasse (13) située dans l'admission d'air (7) du ventilateur, fixé sur une des faces de la carcasse creuse (2) de l'unité d'intérieur.

2. Unité d'intérieur 1, **caractérisé en ce que** la roue de ventilateur (8) comprend un anneau plat (15) qui unit les aubes (9) de ladite roue, qui se projettent depuis l'admission d'air vers les extrémités du ventilateur (7), l'anneau étant uni au rotor (14) du moteur d'entraînement (12) du ventilateur (5), qui est un moteur de rotor externe, et **en ce que** le stator (10) dudit moteur est fixé sur la face (17) de la carcasse (2) attenante à l'anneau de la roue de ventilateur par des supports (16).

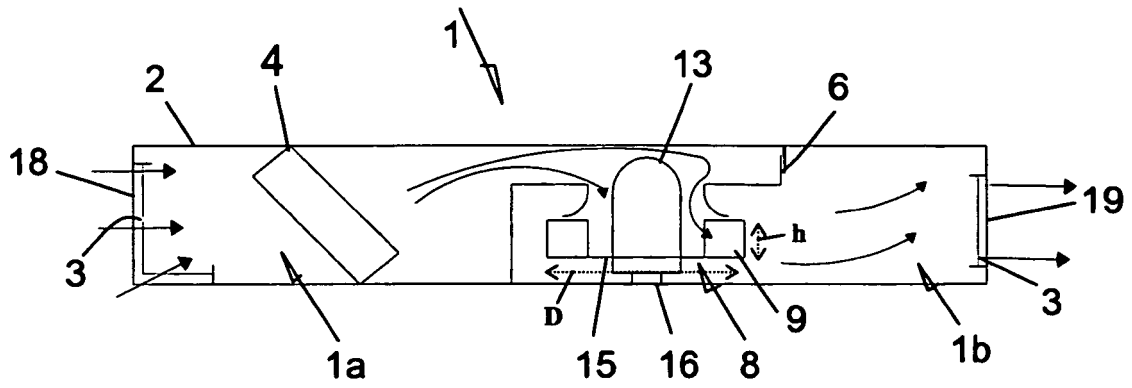

Fig. 1

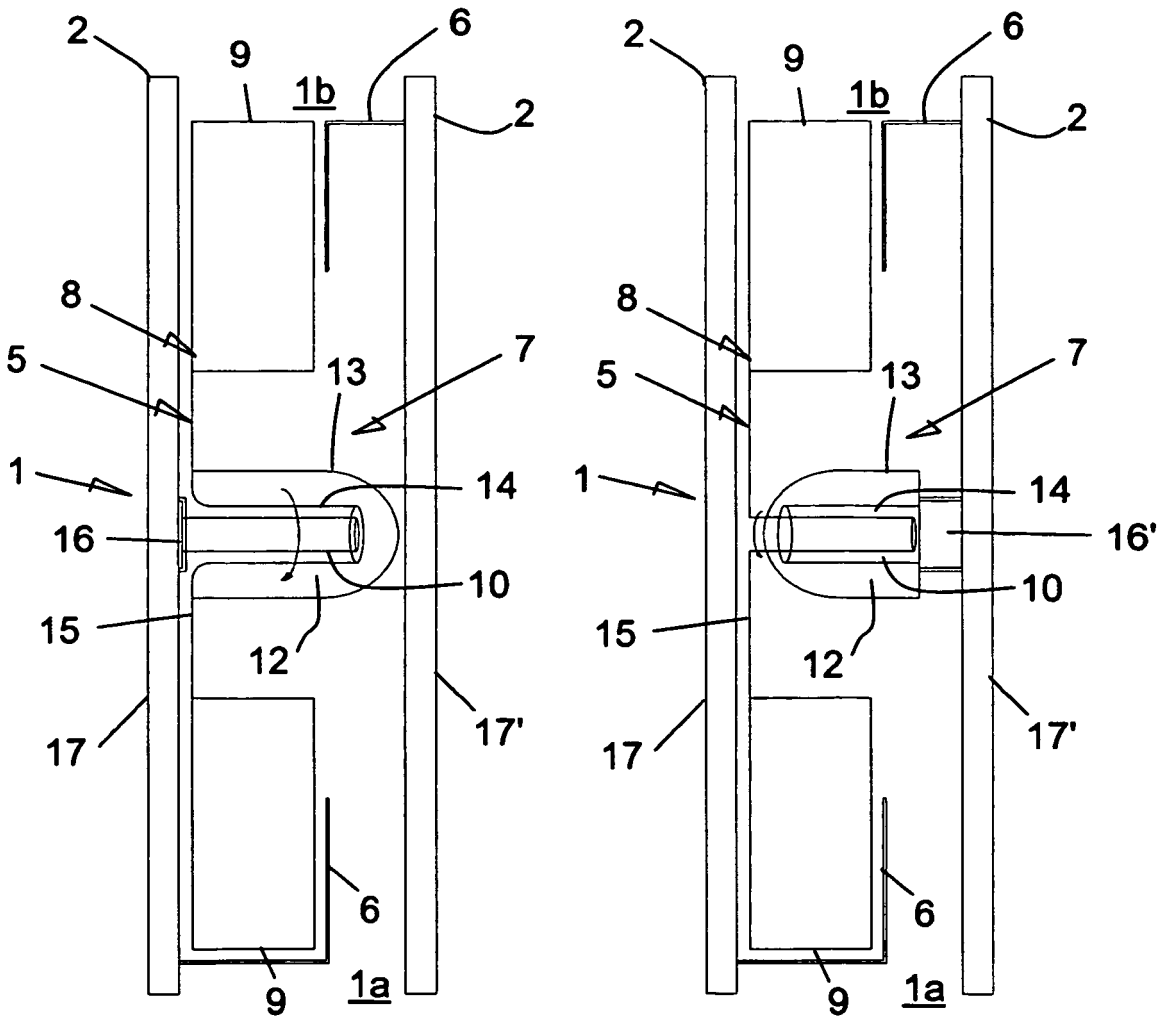

Fig. 2a

Fig. 2b

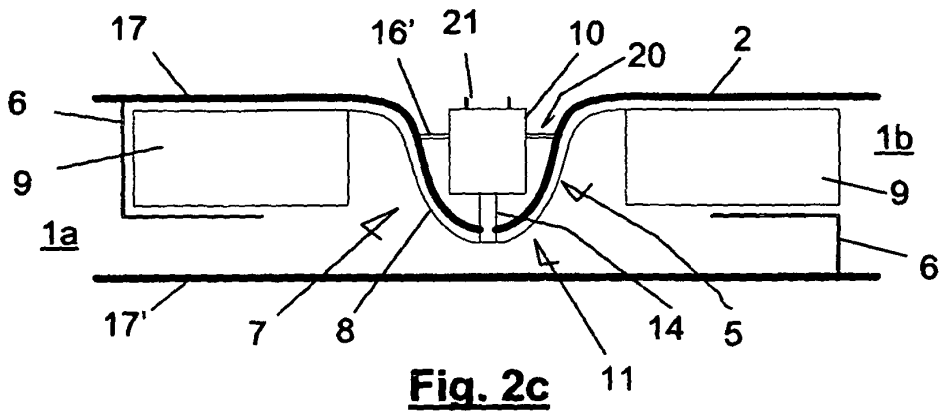

Fig. 2c

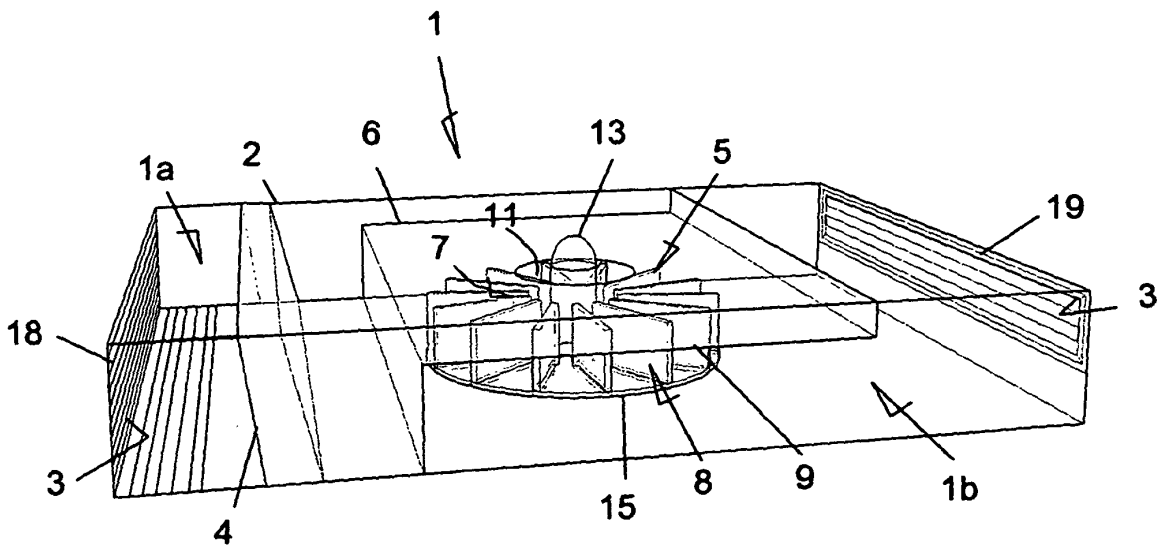

Fig. 3

REFERENCES CITED IN THE DESCRIPTION

This list of references cited by the applicant is for the reader's convenience only. It does not form part of the European patent document. Even though great care has been taken in compiling the references, errors or omissions cannot be excluded and the EPO disclaims all liability in this regard.

Patent documents cited in the description

- WO 3033965 A [0003]
- US 5823002 A [0004]