



US00D354598S

# United States Patent [19]

[11] Patent Number: Des. 354,598

Poten et al.

[45] Date of Patent: \*\* Jan. 17, 1995

## [54] COMBINED DOLLY AND RAMP FOR MOTOR VEHICLES

[75] Inventors: Peter-Randolf Poten, Nettersheim; Karl Steffens, Dahlem; Gunter Gebhardt, Stadtkyll, all of Germany

[73] Assignee: Diehl GmbH & Co., Nurnberg, Germany

[\*\*] Term: 14 Years

[21] Appl. No.: 11,882

[22] Filed: Aug. 16, 1993

### [30] Foreign Application Priority Data

Feb. 17, 1993 [DE] Germany ..... 9301392

[52] U.S. Cl. .... D34/23; D34/28; D34/32

[58] Field of Search ..... D34/12, 23, 32, 28; 280/79.11, 652, 638

### [56] References Cited

#### U.S. PATENT DOCUMENTS

D. 319,131 8/1991 Smeitink ..... D34/12

4,127,202 11/1978 Jennings et al. .... 280/79.11

4,166,638 9/1979 De Prado ..... 280/79.11

Primary Examiner—Kay H. Chin  
Attorney, Agent, or Firm—Scully, Scott, Murphy & Presser

## [57] CLAIM

The ornamental design for a combined dolly and ramp for motor vehicles, as shown and described.

## DESCRIPTION

FIG. 1 is a top and side perspective view of a combined dolly and ramp for motor vehicles showing our new design, the ramp section has been omitted for clarity of illustration;

FIG. 2 is a top plan view of FIG. 1, a portion of the strap is shown broken away for convenience of illustration;

FIG. 3 is a side elevational view of FIG. 2, the opposite elevational view being a mirror image of that shown;

FIG. 4 is a bottom plan view of FIG. 2;

FIG. 5 is a rear elevational view of FIG. 2;

FIG. 6 is a front elevational view of FIG. 2;

FIG. 7 is a top perspective view of the ramp section thereof;

FIG. 8 is a rear elevational view of FIG. 7;

FIG. 9 is a front elevational view of FIG. 7;

FIG. 10 is a top plan view of FIG. 7;

FIG. 11 is a side elevational view of FIG. 7, the opposite side elevational view being a mirror image of that shown;

FIG. 12 is a top plan view of FIG. 7;

FIG. 13 is a top and side perspective view of the combined dolly and ramp for motor vehicles, the ramp section shown positioned in the wheel well of the dolly; and,

FIG. 14 is a top and side perspective view thereof showing the ramp portion in an extended operative condition.

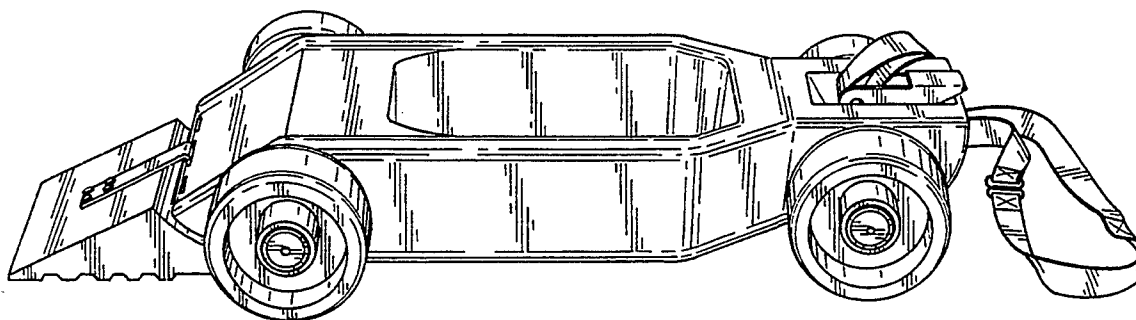
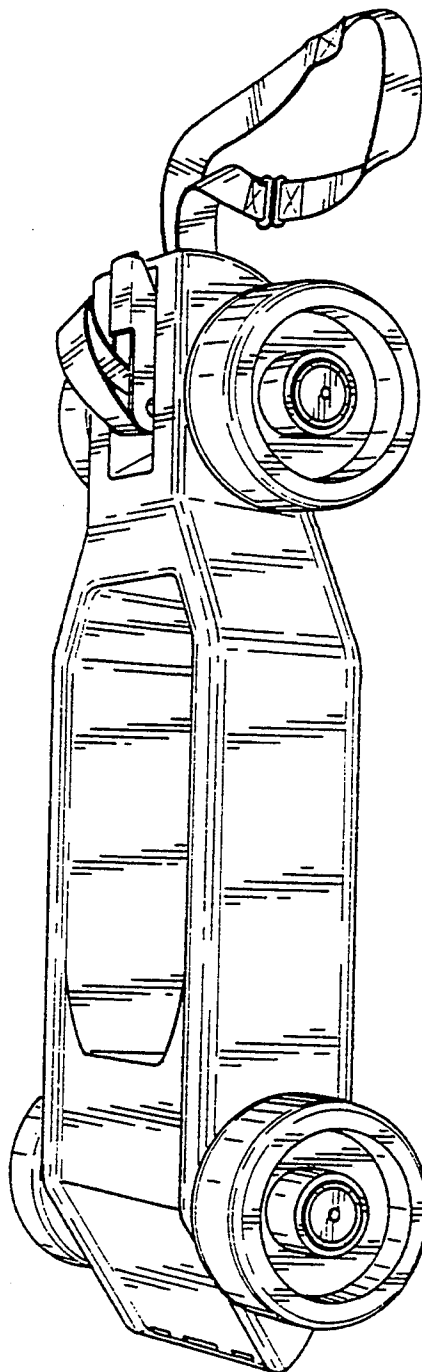

FIG. 1



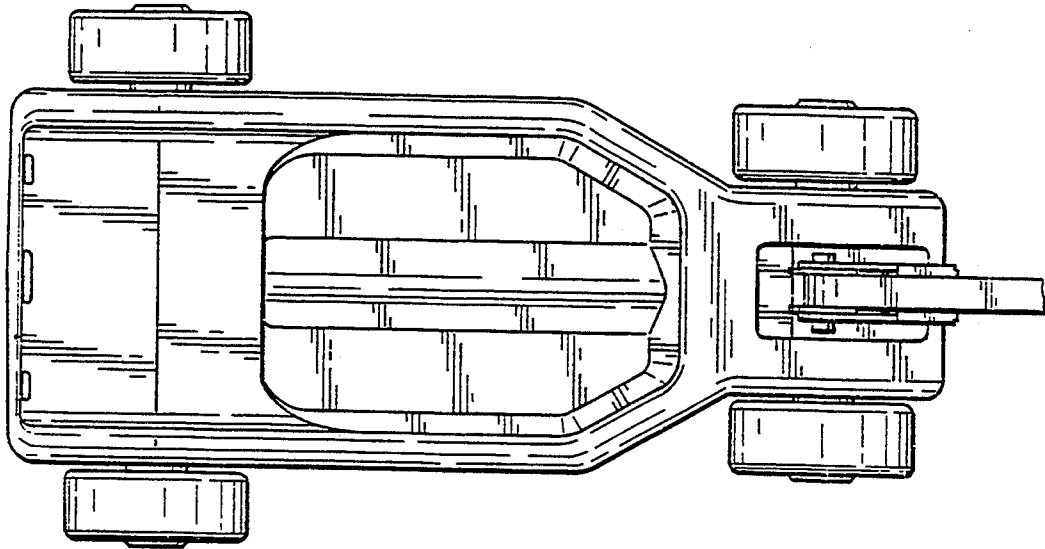

FIG. 2

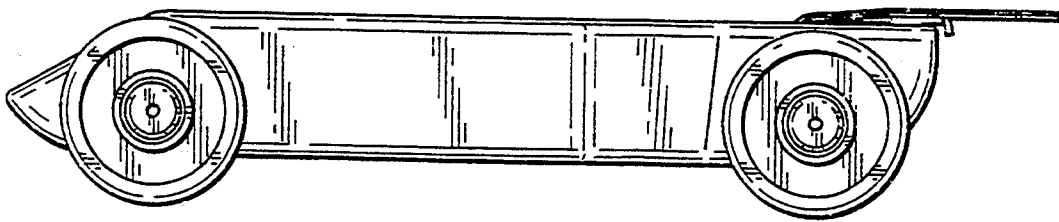

FIG. 3

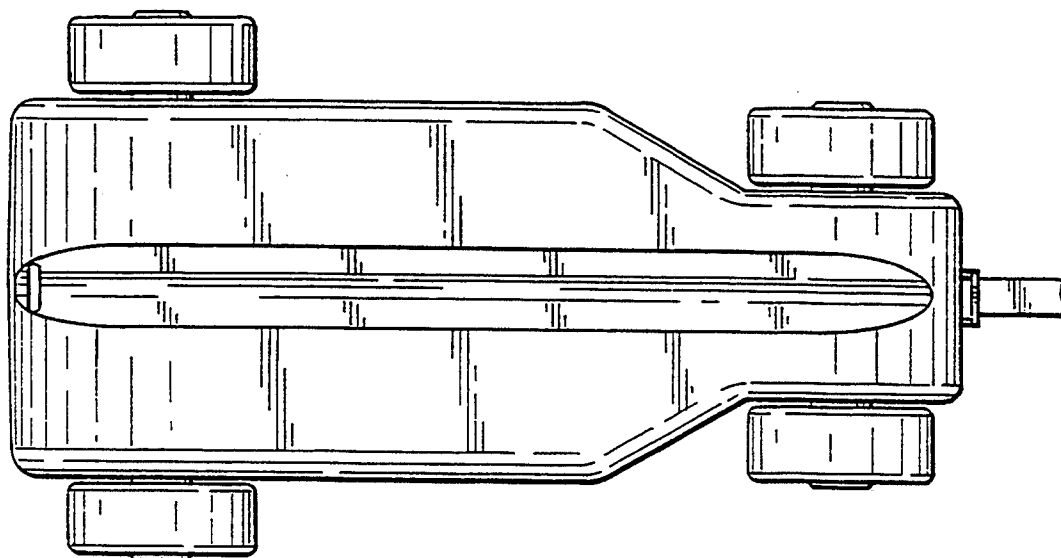

FIG. 4

FIG. 5

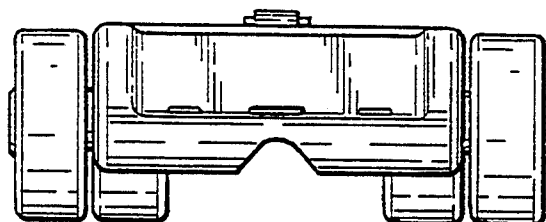
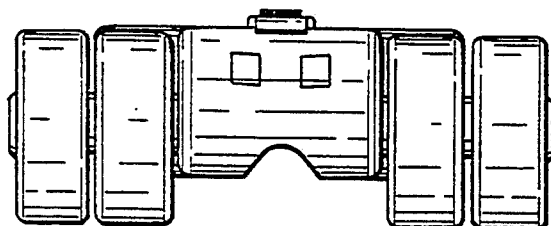

FIG. 6



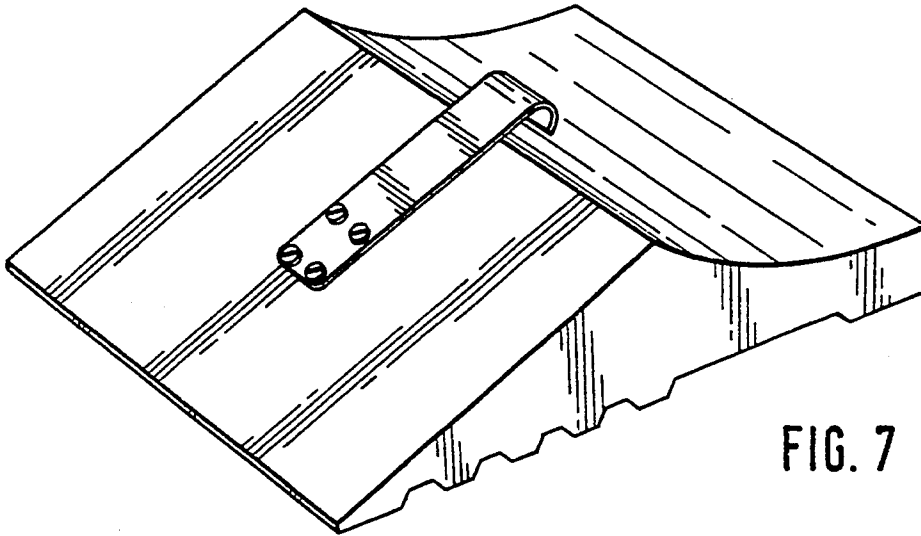

FIG. 7

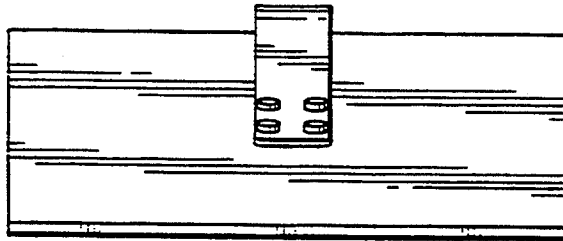

FIG. 8

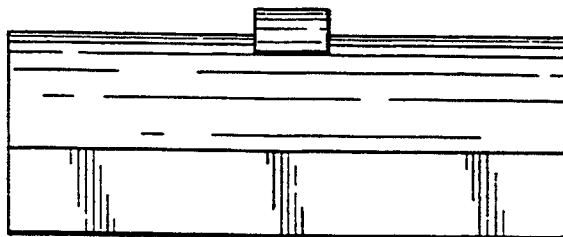

FIG. 9

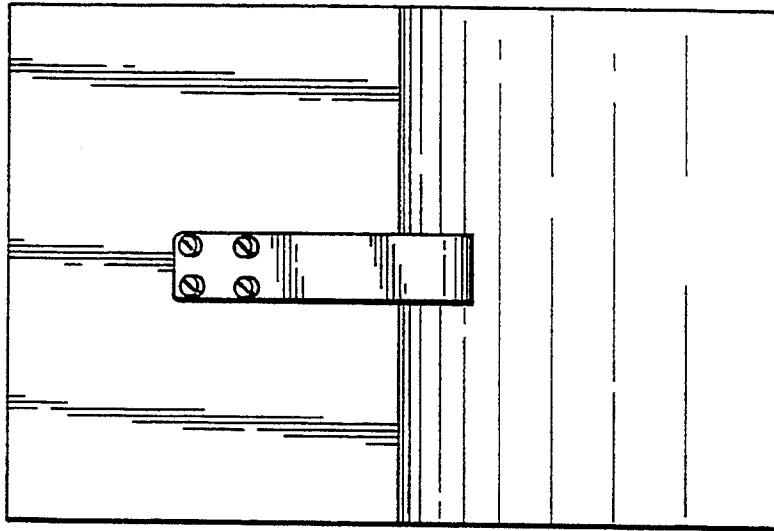

FIG. 10

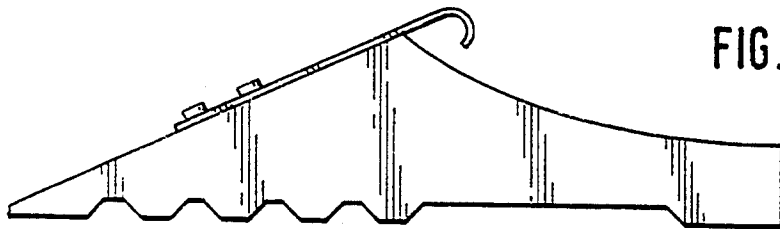

FIG. 11

FIG. 12

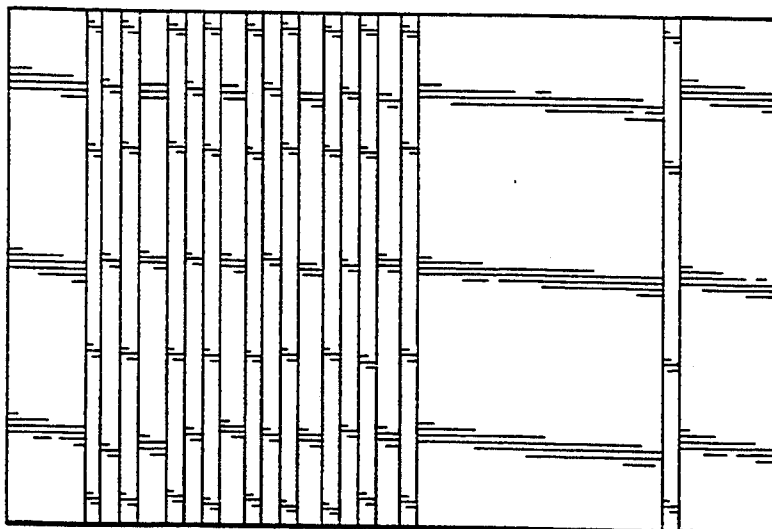

FIG. 13

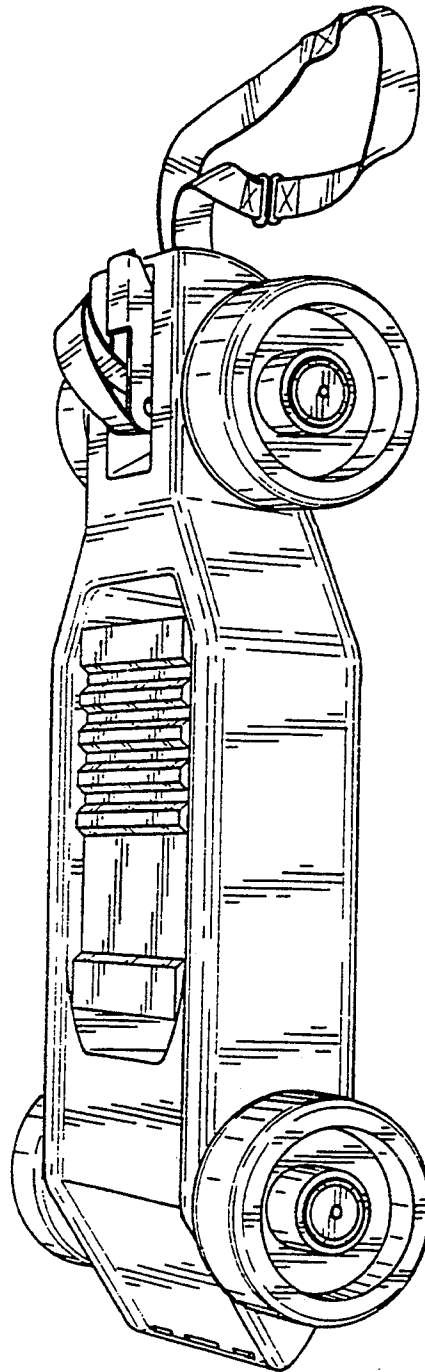

FIG. 14

