

C. E. SKINNER.
 WINDING COIL FOR DYNAMO ELECTRIC MACHINES.
 APPLICATION FILED OCT. 7, 1908.

999,893.

Patented Aug. 8, 1911.

Fig. 1.

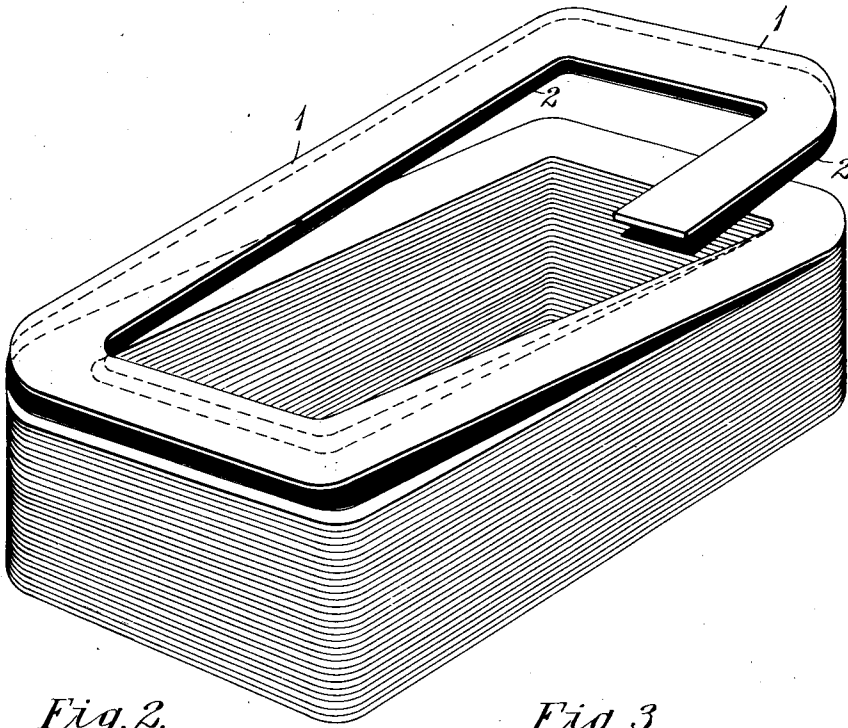

Fig. 2.

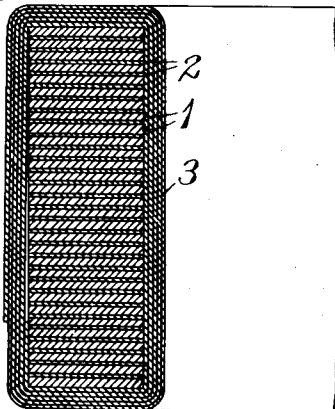
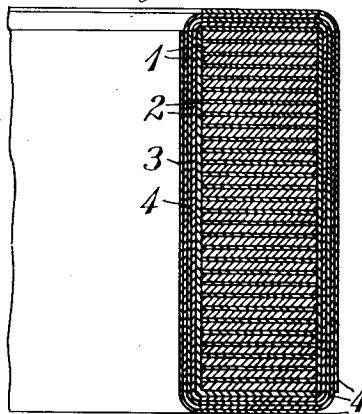

Fig. 3.



WITNESSES:

Fred H. Miller
R. J. Dearborn

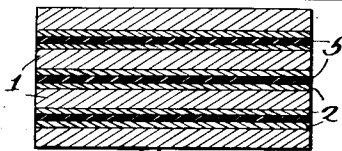

Fig. 4.

INVENTOR
Charles E. Skinner
 BY
Wesley S. Carr
 ATTORNEY

UNITED STATES PATENT OFFICE,

CHARLES E. SKINNER, OF WILKINSBURG, PENNSYLVANIA, ASSIGNOR, BY MESNE ASSIGNMENTS, TO WESTINGHOUSE ELECTRIC & MANUFACTURING COMPANY, OF EAST PITTSBURG, PENNSYLVANIA, A CORPORATION OF PENNSYLVANIA.

WINDING-COIL FOR DYNAMO-ELECTRIC MACHINES.

999,893.

Specification of Letters Patent.

Patented Aug. 8, 1911.

Application filed October 7, 1908. Serial No. 456,609.

To all whom it may concern:

Be it known that I, CHARLES E. SKINNER, a citizen of the United States, and a resident of Wilksburg, in the county of Allegheny and State of Pennsylvania, have invented a new and useful Improvement in Winding-Coils for Dynamo-Electric Machines, of which the following is a specification.

My invention relates to coils for electrical apparatus, and it has for its object to provide a coil that shall be simple and fireproof in construction and adapted for use at relatively high temperatures.

Field coils for dynamo-electric machines are often constructed by winding copper strap or ribbon into a rectangular helix, and since the voltage between turns in coils of this character is relatively low, strips of insulating material have usually been inserted between the turns of the helix in preference to wrapping the conductor with insulating tape or completely covering it by other means, in order to improve the ventilation of the winding.

According to my present invention, I employ metal foil or very thin metal ribbon which has been so treated as to produce a hard film or coating of insulation on its surface. By this means, the space occupied by the insulation so produced is relatively small, since foil of approximately one-thousandth of an inch in thickness may be employed, and, in addition to this advantage, the coil is rendered fireproof and capable of operation at high temperatures.

It will be readily understood by those skilled in the art that the electrical design of a coil to which the aforesaid insulation is to be applied, may be so modified as to effect a material saving in the amount of copper required.

Figure 1 of the accompanying drawing is a perspective view of a coil constructed in accordance with my invention, and Figs. 2 and 3 are sectional elevations of the coil of Fig. 1 with insulating wrappings of heat-conducting material applied thereto. Fig. 4 is a sectional elevation, on a larger scale, of a portion of a coil disclosing a modified insulating structure embodying my invention.

Referring to the drawings, the coil here illustrated comprises a plurality of turns of conducting strap or ribbon, which, together,

constitute a substantially rectangular helix, the turns being wound on edge so that the flat surfaces of the ribbon are adjacent to each other. After the coil is formed of bare copper ribbon or strap, strips 2 of metal foil are interposed between the adjacent turns of the helix, said strips having first been treated to produce the insulating coating or film on their surfaces. The edges of the conducting strap of which the coil is wound are insulated by a close wrapping 3 of metal foil, similar to that employed between the turns of the helix, the necessary insulation being obtained by treating the foil as hereinafter pointed out and by employing any desired number of overlapping turns. The wrapping is bound as tightly as possible to the coil in order to improve its heat-conducting properties by excluding films of air which, when heated, become poor heat-conductors. For mechanical reasons, the thickness of the foil or plate used in the wrapping 3 may be increased and the wrapping built up of overlapping angle plates 4 arranged to telescope together, as shown in Fig. 3.

Where the insulation is required to withstand relatively high voltages, sheets of mica may be interposed between layers of the metal foil as shown in Fig. 4 of the drawings.

An insulating fabric constructed in the manner just referred to has the advantage of being fireproof, while the aluminum foil holds the mica flakes in position.

I prefer to employ strips of aluminum foil of substantially one-thousandth (1/1000) of an inch in thickness, in order that a minimum amount of space may be occupied by the insulation and in order that the fireproof insulating film may readily be formed on its surface. A specially good result may be obtained by passing the strip of aluminum through a bath of ammonium borate or some other suitable liquid and at the same time passing current through the electric conductor and the bath, thereby producing an aluminum-oxid film which is relatively hard, not readily destroyed by heat, and at the same time affords adequate insulation for a considerable voltage which is far in excess of the voltage which usually obtains between adjacent turns of the field coils of a dynamo-electric machine.

It will be readily understood that my invention is not restricted to any specific type or kind of coil, and I desire that only such limitations shall be imposed as are indicated in the appended claims.

I claim as my invention:

1. A fireproof coil for electrical apparatus comprising a plurality of turns of conducting material separated by metal foil treated to produce an insulating coating or film on its surface.

2. A fireproof coil for electrical apparatus comprising a plurality of turns of copper strap or ribbon and a suitable strip or layer of metal foil interposed between adjacent turns, said metal foil being first treated to provide an insulating film on its surface.

3. A fireproof coil for electrical apparatus comprising a plurality of turns of con-

ducting material separated by metal foil treated to produce an insulating film on its surface, and a wrapping of similar material.

4. A fire-proof coil for electrical apparatus comprising a plurality of turns of conducting material separated by insulating material or fabric comprising alternate layers of aluminum foil treated to produce an insulating coating on the surface and mica flakes, the mica being held in position by the foil.

In testimony whereof, I have hereunto subscribed my name this 21st day of Sept., 1908.

CHARLES E. SKINNER.

Witnesses:

LILLIAN I. JOHN,
BIRNEY HINES.