

March 8, 1955

E. PROTH

2,703,444

GARMENT SUPPORTING AND STRECHTING MEANS

Filed Sept. 5, 1952

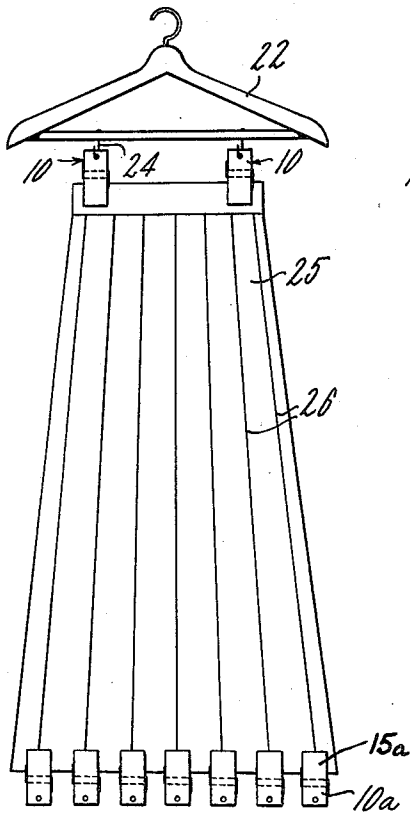
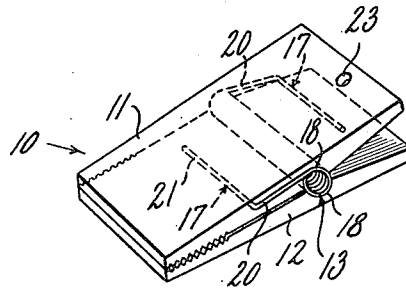
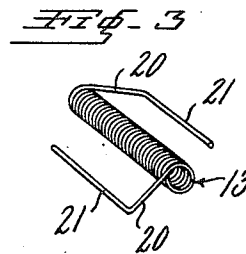
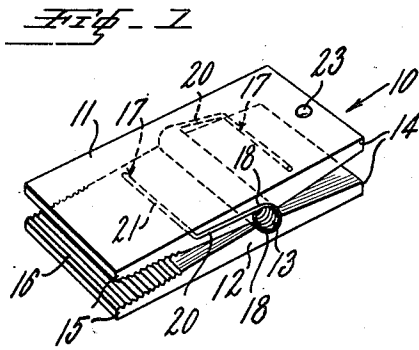

Fig. 2

Fig. 4

INVENTOR.
ELIZABETH PROTH
BY *Sam M. Strauss*
AGT.

1

2

2,703,444

GARMENT SUPPORTING AND STRETCHING MEANS

Elizabeth Proth, La Paz, Bolivia

Application September 5, 1952, Serial No. 308,030

1 Claim. (Cl. 24—253)

This invention relates to garment supporting means and more particularly to devices for stretching and keeping garments, such as skirts and the like in pre-shaped condition.

It is one of the objects of the present invention to provide means facilitating the engagement of predetermined parts of a garment, such as the pleats of a skirt, for maintaining such pleats in desired condition and to avoid deformation thereof.

It is another object of the present invention to provide means affording ready application and engagement of clamping devices over and along a certain length of area of folds or pleats for stretching and pressing the same.

Yet a further object of the present invention is to provide means conducive to a simplified structure of clamping or stretching devices which may be connected with a garment hanger or other supporting device from which a pleated skirt may depend and which may also be directly connected to such piece of wearing apparel to keep the folds or pleats thereof in desired position.

The above and other objects and features will become apparent from the following detailed description, reference being had to the accompanying drawing in which:

Fig. 1 shows the clamping device constructed according to the invention, when it is opened a relatively large amount;

Fig. 2 shows the clamping device constructed according to the invention;

Fig. 3 shows the spring element used in conjunction with the clamping device; and

Fig. 4 shows the clamping device mounted on a supporting device and on a wearing apparel.

Referring more particularly to the drawing, the clamping device 10 which is made from plastic, wood or like material includes a pair of identical body or plate members 11 and 12, which are held together by coiled spring fastening means 13. Each member 11 or 12 has a handle or head portion 14 tapering outwardly as shown and has at its opposite end a clamping or gripping jaw or portion 15 of greater length than head portion 14 also tapering outwardly and having serrated or striated portion 16 for enhancing friction between said gripping portions 15. Each body 11 or 12 includes a bore or passage 17 extending from respective side or lateral faces of said plate members. The head 14 provides a convenient finger grip.

The inner surface of each body member 11 and 12 is formed with an inner transverse grooved or arcuate recess 18 from which head 14 and grip portion 15 taper outwardly. Coil spring means 13 is seated within the complementary groove portions 18 of the assembled body members 11 and 12, said groove portions 18 being of slightly larger radius than said coiled portion of spring 13, the opposite ends of spring 13 being formed as arms 20. The outer ends of the arms 20 are intumed, to form parallel extremities 21, and when the spring 13 is correctly fitted in the recesses 18, said extremities 21 are adapted to engage and to be retained in the respective bores or openings 17 extending from the side wall surfaces of said body members thereinto. The spring 13 is so made that the intumed extremities or ends 21 exert in-

wardly directed pressure on the body members 11 and 12 so that they are restrained against pivotal movement and hold said members in position for operation.

To assemble the parts of the clamping device, the two body members 11, 12 are held laterally offset so that the recesses 18 are still opposite each other. The intumed ends 21 of spring 13 are each engaged in the respective bores 17, and the body members 11, 13 are slid toward each other until they abut against spring arms 20.

When the clamping device is so assembled, as shown in Fig. 2, the pressure of the spring 13 holds the body members together and relative lateral movement of the clamping device is prevented.

As shown in Fig. 4, the clamping device 10 may be connected with a garment hanger 22 by inserting a hook 24 mounted on said garment hanger within the opening 23 on head 14, which opening may be provided in one or both of the body members 11, 12. The clamping jaws 15 are engaged with wearing apparel 25 to securely support the latter on the clothes hanger. Other clamping devices 10a have substantially the entire length of the clamping jaws 15a engaged along a certain length of folds or pleats 26 on the wearing apparel in order to stretch and press said folds or pleats 26.

Although only one embodiment of the invention has been described and shown in the drawing, it should be noted that the invention may be realized in modified form and adaptations of the arrangements herein disclosed may be made as may readily occur to persons skilled in the art without constituting a departure from the spirit and scope of the invention as defined in the objects and in the appended claims.

Having thus described the invention, what is claimed as new and desired to be secured by Letters Patent, is:

A clamping device comprising two body members forming elongated plates having front ends and lateral faces, groove means extending transversely to and approximately at the center of said plates and partly into the surfaces thereof facing each other, each of said plates including a head portion and a grip portion, said grip portions of said plates being planar and extending normally in contact with each other from said front ends to said groove means, friction-enhancing surface means on said grip portions adjacent said front ends, whereby uninterrupted engagement from said front ends to said groove means of said grip portions takes place when an article is placed between the latter, and spring means including a coiled portion and arms extending from either end of said coiled portion, each of said arms being provided with a first arm portion and with a second arm portion, said first arm portions extending in opposite directions to each other and at right angles to the longitudinal axis of said coiled portion, said second arm portions extending from the respective first arm portions at right angles thereto and substantially parallel to each other and to said longitudinal axis of said coiled portion, one of said grip portions being provided with a first bore for retention therein of one of said second arm portions, the head portion of the other of said plates being provided with a second bore for retention therein of said other of said second arm portions, whereby said coiled portion when accommodated in said groove means forms a pivot about which said planar grip portions may swing upon actuation of said head portions relative to each other, said first arm portions extending, respectively, in contact with said lateral faces of said plates.

References Cited in the file of this patent

UNITED STATES PATENTS

365,755	Moore	June 28, 1887
1,398,288	Watkins	Nov. 29, 1921
2,013,275	Key	Sept. 3, 1935