

June 13, 1961

S. B. SEELEY  
STOPPER ROD ASSEMBLIES

2,987,787

Filed Oct. 15, 1959

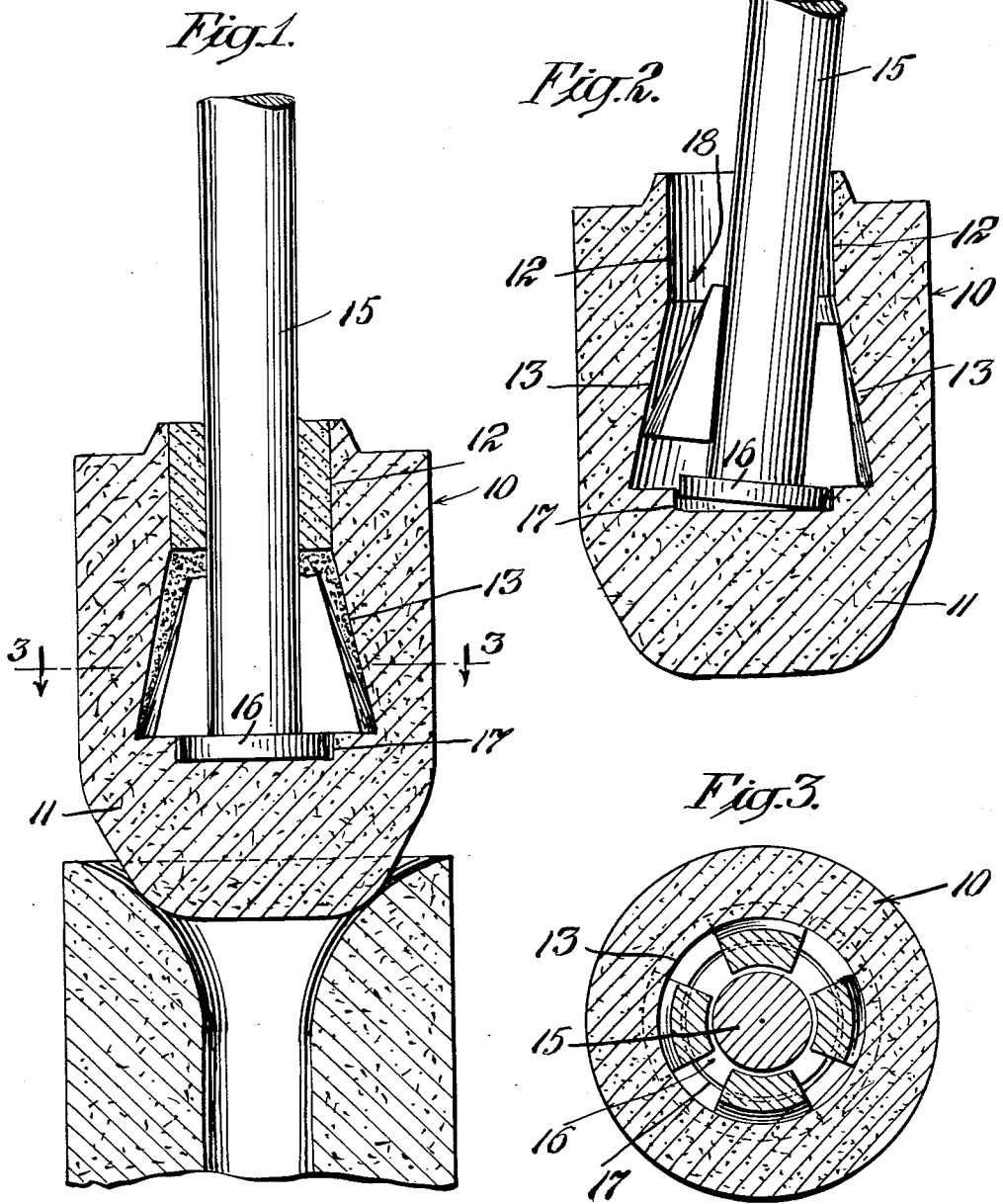

INVENTOR.  
SHERWOOD B. SEELEY  
BY  
*Guthrie W. Hawley*  
ATTORNEY

1

2,987,787

## STOPPER ROD ASSEMBLIES

Sherwood B. Seeley, Staten Island, N.Y., assignor to The Joseph Dixon Crucible Company, Jersey City, N.J., a corporation of New Jersey  
Filed Oct. 15, 1959, Ser. No. 846,690  
1 Claim. (Cl. 22-85)

This invention relates to stoppers and stopper rod assemblies.

In the steel industry, the increased steel tonnages require a longer pouring time and higher pouring temperatures and have given rise to a real problem in stopper rod assemblies.

In some stopper rod assemblies the stopper bolt is inserted through a bore in the bottom or the stopper, the bore being plugged after the bolt is in place. The bolt extends upwardly and is connected to the rod. The increased pouring temperature and increased tonnages causes accelerated erosion at the bottom or nose portion of the stopper, particularly in the case of stoppers having plugged bottoms.

This invention has for its salient object to provide a stopper having a solid nose.

Another object of the invention is to provide a stopper rod assembly that is simple and practical in construction and is so constructed and arranged that the stopper rod can be easily and quickly assembled in the stopper and can be securely connected thereto.

Another object of the invention is to provide a stopper rod assembly so arranged as to partially insulate the rod or the bolt from the stopper.

Further objects of the invention will appear from the following specification taken in connection with the drawings which form a part of this application, and in which:

FIG. 1 is a vertical sectional elevation of the stopper rod assembly constructed in accordance with the invention;

FIG. 2 is a sectional elevation illustrating the manner in which the lower end of the stopper rod or stopper bolt is assembled in and connected to the stopper; and

FIG. 3 is a transverse sectional elevation taken substantially on line 3-3 of FIG. 1, looking in the direction of the arrows.

In the particular embodiment of the invention illustrated, there is shown a stopper 10 having a solid nose 11 and having a downwardly extending bore 12 which merges with an undercut tapered recess 13.

The stopper rod by means of which the stopper is lifted is usually connected to a stopper bolt 15, and the bolt 15 has a flange or washer 16 at its lower end. In the present embodiment of the invention the stopper rod or bolt 15 is inserted and moved downwardly through the bore 12 into the recess 13 and, if desired, the recess may have an extension 17 dimensioned to receive the flange or

2

washer 16. This, however, is not necessary to the operation of the invention.

FIG. 2 illustrates the manner in which the stopper rod or stopper rod bolt 15 is secured to the stopper. The bolt or rod 15 is tilted or canted, as shown, and a plurality of wedge-shaped blocks or locking members B are inserted in the recess 13 through the portion 18 of the bore 12. After they have been so inserted, the bolt or rod 15 is alined to a vertical position, as shown in FIG. 1, and the wedge-shaped blocks will lock the bolt or rod in the recess 13 in the manner shown in FIG. 1. The space around the bolt or rod in the bore 12 is preferably filled with cement. The voids may be filled with a fine refractory grain before cementing. In this manner the bolt or rod which is connected to the bolt is securely connected to the stopper.

Although one specific embodiment of the invention has been particularly shown and described it will be understood that the invention is capable of modification and that changes in the construction and in the arrangement of the various cooperating parts may be made without departing from the spirit or scope of the invention as expressed in the following claim.

What I claim is:

A stopper rod assembly comprising a stopper having portions forming an undercut recess communicating with a bore of a reduced cross-section opening into the upper end of said stopper rod, stopper rod means including a lower flange portion extendable axially through said stopper bore and receivable in said recess in angular relation to said bore, a plurality of locking means individually receivable through said stopper bore and including an inner surface portion complementary to a fragmentary portion of the outer surface of said rod means and disposed entirely in said stopper recess and circumferentially spaced about said rod means, said locking means engaging said rod means flange portion and combining to prevent axial withdrawal of said rod means from said recess and bore of said stopper, retaining means circumposed about said rod means in said stopper bore for retaining the assembly integral, said stopper recess having a frusto-conical configuration, and the outer surfaces of said locking means having a fragmentary frusto-conical configuration and disposed inwardly of said stopper frusto-conical recess, and a refractory material in said recess surrounding said locking elements and filling the spaces therebetween.

### References Cited in the file of this patent

#### UNITED STATES PATENTS

117,918	Ostrander	Aug. 8, 1871
1,843,175	Sears	Feb. 2, 1932

#### FOREIGN PATENTS

12,291	Great Britain	May 31, 1904
--------	---------------	--------------

UNITED STATES PATENT OFFICE  
CERTIFICATE OF CORRECTION

Patent No. 2,987,787

June 13, 1961

Sherwood B. Seeley

It is hereby certified that error appears in the above numbered patent requiring correction and that the said Letters Patent should read as corrected below.

Column 2, line 29, strike out "rod", first occurrence.

Signed and sealed this 7th day of November 1961.

(SEAL)

Attest:

ERNEST W. SWIDER  
Attesting Officer

DAVID L. LADD  
Commissioner of Patents  
USCOMM-DC