

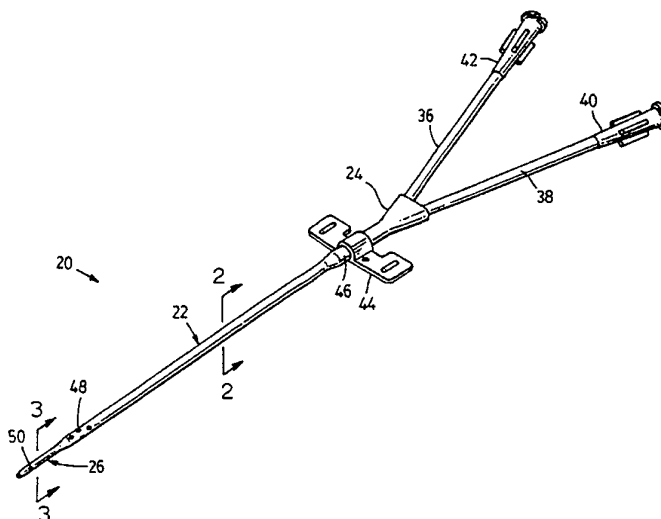

INTERNATIONAL APPLICATION PUBLISHED UNDER THE PATENT COOPERATION TREATY (PCT)

<p>(51) International Patent Classification⁵ : A61M 5/158, 25/00</p>	<p>A1</p>	<p>(11) International Publication Number: WO 94/21315 (43) International Publication Date: 29 September 1994 (29.09.94)</p>
<p>(21) International Application Number: PCT/CA94/00150 (22) International Filing Date: 16 March 1994 (16.03.94) (30) Priority Data: 08/031,982 16 March 1993 (16.03.93) US (71) Applicant: MED-PRO DESIGN, INC. [CA/CA]; 159 Donnelly Drive, Mississauga, Ontario L5G 2M3 (CA). (72) Inventor: MARTIN, Geoffrey, S.; 159 Donnelly Drive, Mississauga, Ontario L5G 2M3 (CA). (74) Agents: SCOTT, Christopher, R. et al.; Rogers & Scott, 214 Randall Street, Oakville, Ontario L6J 1P7 (CA).</p>	<p>(81) Designated States: AT, AU, BB, BG, BR, BY, CA, CH, CN, CZ, DE, DK, ES, FI, GB, HU, JP, KP, KR, KZ, LK, LU, LV, MG, MN, MW, NL, NO, NZ, PL, PT, RO, RU, SD, SE, SK, UA, UZ, VN, European patent (AT, BE, CH, DE, DK, ES, FR, GB, GR, IE, IT, LU, MC, NL, PT, SE), OAPI patent (BF, BJ, CF, CG, CI, CM, GA, GN, ML, MR, NE, SN, TD, TG).</p> <p>Published <i>With international search report.</i></p>	

(54) Title: CATHETERS AND METHOD OF MANUFACTURE



(57) Abstract

The invention provides a dual lumen catheter (20) comprising outer and inner tube materials (28, 30). A main portion (22) extends axially and has a selected first cross section and includes main portions of the respective outer and inner tube materials which together define an annular intake lumen (32) and a main part of a return lumen (34) contained inside the intake lumen. A transition portion (67) is made up integrally of both the outer and inner tube materials and has a second cross section smaller than the first cross section. The transition portion extends axially from the distal end of the main portion and this can be extended to include a tip portion (65) made up only of outer tube material and which extends axially from the transition portion. The transition portion on its own, or with the tip portion, defines a tip section (26) which is a continuation of said main part of the return lumen to complete the return lumen. A method of manufacturing the catheter is also disclosed.

FOR THE PURPOSES OF INFORMATION ONLY

Codes used to identify States party to the PCT on the front pages of pamphlets publishing international applications under the PCT.

AT	Austria	GB	United Kingdom	MR	Mauritania
AU	Australia	GE	Georgia	MW	Malawi
BB	Barbados	GN	Guinea	NE	Niger
BE	Belgium	GR	Greece	NL	Netherlands
BF	Burkina Faso	HU	Hungary	NO	Norway
BG	Bulgaria	IE	Ireland	NZ	New Zealand
BJ	Benin	IT	Italy	PL	Poland
BR	Brazil	JP	Japan	PT	Portugal
BY	Belarus	KE	Kenya	RO	Romania
CA	Canada	KG	Kyrgyzstan	RU	Russian Federation
CF	Central African Republic	KP	Democratic People's Republic of Korea	SD	Sudan
CG	Congo	KR	Republic of Korea	SE	Sweden
CH	Switzerland	KZ	Kazakhstan	SI	Slovenia
CI	Côte d'Ivoire	LI	Liechtenstein	SK	Slovakia
CM	Cameroon	LK	Sri Lanka	SN	Senegal
CN	China	LU	Luxembourg	TD	Chad
CS	Czechoslovakia	LV	Latvia	TG	Togo
CZ	Czech Republic	MC	Monaco	TJ	Tajikistan
DE	Germany	MD	Republic of Moldova	TT	Trinidad and Tobago
DK	Denmark	MG	Madagascar	UA	Ukraine
ES	Spain	ML	Mali	US	United States of America
FI	Finland	MN	Mongolia	UZ	Uzbekistan
FR	France			VN	Viet Nam
GA	Gabon				

DESCRIPTIONCATHETERS AND METHOD OF MANUFACTURETECHNICAL FIELD

5 This invention relates to dual lumen catheters for use in haemodialysis treatments and more particularly to a dual lumen catheter having coaxial intake and return lumens.

BACKGROUND ART

10 Haemodialysis treatments have been developed since the early 1960s using a variety of combinations and arrangements of catheters. The earliest treatments were conducted using two needles in the same vein and this subsequently led to pioneer work done by Dr. Sheldon in England who used two flexible catheters which could be left in place for limited periods. Some practitioners
15 proposed the use of a dual flow catheter because this could be entered through a single incision rather than two. From this two basic types were developed. One was a coaxial catheter with the intake lumen surrounding the return lumen, and the other a catheter having side-by-side lumens either in individual tubes
20 connected to one another or in a single extrusion defining two lumens.

 Catheters having side-by-side lumens have the disadvantages that because the lumens are side-by-side, the intake openings can be in one side of the catheter only. As a consequence
25 of this, if the catheter were to attach itself to the wall of a vein due to suction applied to the intake lumen, then of course the flow would stop. Medical staff then have to move the catheter by rotating it until blood again flows. This is a very delicate manipulation which is normally performed only by a qualified
30 medical practitioner who must be available at all times in case the

flow is discontinued.

This disadvantage has resulted in renewed interest in coaxial devices which can be made to have openings in any part of the wall of the catheter. As a result, no matter where the catheter
5 may rest against a vein, some of the intake openings remain patent. There is then less likelihood that during use the catheter must be serviced by a trained medical practitioner.

Coaxial catheters are subject to design criteria which can be difficult to meet and which may have contributed to the initial
10 popularity of side-by-side structures. Because the coaxial catheter is inherently less resistant to kinking than side-by-side structures, the tubes used in the structure have had relatively thick walls with the result that the catheter had to also have a larger cross-sectional area than an equivalent side-by-side catheter. One of the reasons for this
15 is that typically the inner tube projected beyond the outer tube to form a distal tip section. Because of this the cross-section of the inner tube has to be chosen to have sufficient rigidity to permit engagement over a Seldinger wire. This consideration set the size of the inner tube.

20 Another approach is taught by U.S. 4493696 to Uldall. The catheter shown in this patent was designed specifically to permit removal of the inner tube between treatments. It was thought at the time of the patent (i.e. about 1980) that such a procedure would be desirable. However, it is now accepted that
25 with modern techniques it is not necessary to remove the inner tube. Also, the inherent disadvantages of accidental separating of the tubes, accurate location of one tube relative to the other, sizing, and the sudden change of section at the end of the inner tube, were all obstacles to the use of this catheter.

30 The present catheter uses a structure which permits a relatively thin walled inner tube to be used to minimize the overall cross-

section of the catheter. Also, the inner tube meets the tip section smoothly to provide a continuous inner lumen at a transition portion where the inner and outer tube materials meet in a permanent bond to minimize the risk of accidental separation and to ensure repeatable manufacturing methods for more constant catheter structures.

DISCLOSURE OF THE INVENTION

In one of its aspects, the invention provides a dual lumen catheter comprising outer and inner tube materials. A main portion extends axially and has a selected first cross-section. The main portion includes main portions of the respective outer and inner tube materials which together define an annular intake lumen and a main part of a return lumen contained inside the intake lumen. A tubular transition portion is made up integrally of both the outer and inner tube materials and has a second cross-section smaller than the first cross-section. The transition portion extends axially from the distal end of the main portion and this can be extended to include a tip portion made up only of outer tube material and which extends axially from the transition portion. The transition portion on its own, or with the tip portion, defines a tip section which is a continuation of said main part of the return lumen to complete the return lumen.

BRIEF DESCRIPTION OF THE DRAWINGS

This invention will be better understood with reference to the drawings in which:

Fig. 1 is an isometric view of a preferred embodiment of a catheter according to the invention;

Fig. 2 is a sectional view on line 2-2 and drawn to a larger scale;

Fig. 3-3 is a sectional view on line 3-3 of Fig. 1 and drawn to the same scale as Fig. 2;

Fig. 4 is a diagrammatic view of a step in the manufacture of a distal end of the catheter;

5 Fig. 5 is a view similar to Fig. 4 and showing a subsequent step in the manufacture of the distal end;

Fig. 6 is a sectional view of a finished distal end of the catheter;

10 Fig. 7 is an isometric view of a proximal end of the main portion of the catheter during manufacture of the proximal end; and

Fig. 8 is a diagrammatic representation of the proximal end prepared ready for moulding a connector at the proximal end of the main body.

BEST MODE FOR CARRYING OUT THE INVENTION

15 Reference is first made to Fig. 1 which illustrates a catheter designated generally by the numeral 20 and consisting of the main portion 22 extending from a trident shaped connector 24 to a distal tip section 26. As seen in Fig. 2, the main portion 22 is made up of an outer tube material 28 and an inner tube material 30
20 spaced radially from one another to define an annular intake lumen 32 and a circular return lumen 34. The return lumen 34 continues beyond the main portion 22 and into the tip section 26 as indicated by the section at Fig. 3. However, there is a transition between the main portion 22 and the tip section involving both the outer and
25 inner tube materials 28, 30 as will be described.

At the proximal end, the trident shaped connector 24 has connected to its respective intake and return tubes 36, 38 having the usual luer connectors 40, 42 to make connection to tubing associated with a dialysis machine or the like.

30 The connector 24 has internal channels connecting the

tubes 36, 38 to the respective lumens 32, 34 (Fig. 2) as will be described more fully with reference to Figs. 7 and 8.

The catheter is completed by the inclusion of a rotatable suture wing 44 mounted on the main section and held in place by a collar 46 locating the wing 44 against the connector 24 for
5 longitudinal positioning of the wing.

As also seen in Fig. 1, the catheter has side openings 48, 50. The openings are spaced circumferentially around the catheter to provide access to the intake lumen 32 and optional side openings
10 50 are provided adjacent the distal end of the catheter to permit a flow from the return lumen 34.

The structure of the tip section 26 will be better understood with reference to the method of manufacture which is illustrated in Figs. 4 and 5.

Reference is next made to Fig. 4 which is a diagrammatic illustration of the early steps in the manufacture of the tip section.
15 As seen in Fig. 4, outer tube material 28 in the form of an extruded round tube is positioned adjacent a RF heating device 52 and contains inner tube material 30 also in the form of an extruded tube
20 of round cross-section. This latter tube has a thinner wall than the outer tube, but this is not shown in order to simplify the drawings.

The material 30 contains a round stainless steel mandrel 54 which projects beyond the distal extremity of the outer tube material 28 and is shaped for engagement in an opening 56 at the
25 inner end of the device 52. This device has an internal shape matching that of the required tip section and includes a tubular main portion 58 extending outwardly from a back wall 60 containing the opening 56, and ending at flared entrance 62 which blends into the main portion 58 with a curvature to be given to the
30 catheter. It will be seen that the inner tube material 30 has an inner diameter matching the outer diameter of the mandrel 54 and the

distal end of the inner tube material 30 terminates inwardly of the distal end of the outer tube material 28 by a distance equal to about one quarter of the length of the cavity in the RF device 52.

Once the parts are arranged as shown in Fig. 4, the RF device 52 is energized to heat the device to a temperature sufficient to cause flow in the thermoplastic materials 28, 30. Once heating has been achieved, the parts shown in Fig. 4 are moved into the device 52 in unison and this movement continues until they take up the position shown in Fig. 5. It will be evident from the arrangement in Fig. 4 that the end of the mandrel 54 is first engaged in the opening 56 and then the distal end of the outer tube material 28 meets the wall 60 and this ensures that the material about the mandrel forms a constant wall thickness. While this is happening, the distal end of the inner tube material 30 will meet the converging outer wall material 28 and because of the heat, the two will blend into one over a significant length of the device 52, indicated by a separate and closer form of cross-hatching in Fig. 5. This is better illustrated in Fig. 6.

As seen in Fig. 6, tip section 26 has a length "a" which may include a tapered tip portion 64 formed either during or after the procedure described with reference to Figs. 4 and 5. The purpose of this is simply to improve the utility of the catheter in association with a Seldinger wire which is fed through the centre of the catheter.

As also seen in Fig. 6, the tip section 26 is made up of a tip portion 65 having a length "c" and a transition portion 67 having a length "d" corresponding to the closer cross-hatching mentioned with reference to Fig. 5. Portion 65 is made up of the outer tube material 28 whereas portion 67 is made up of both outer and inner tube materials 28, 30. There is also a tapered portion 66 having a length "b" made up of the outer tube material.

This arrangement of manufacture permits a relatively light thin walled inner tube material 30 to be used within more robust outer tube material 28. The resulting return lumen 34 (Fig. 2) is smooth walled and continuous and is made up of outer tube material 28 at the tip portion 65, both outer and inner tube materials 28, 30 at the transition portion 67, and of the inner tube material alone over the main portion of the return lumen corresponding to portion 22 (Fig. 1) of the catheter.

As mentioned, it is desirable that the inner tube material 30 have a relatively thin wall in order to minimize the space lost to flow within the outer tube 28, and consequently to reduce the area of cross-section of the catheter. Because the outer tube material 28 is sufficiently robust, it can be used advantageously to form the tip portion 65.

It will also be appreciated that because the outer tube material 28 is being reduced in diameter as it is deformed, it will lengthen. Consequently the length of the tip section is a function of the reduction in diameter and wall thickness.

Reference is next made to Figs. 7 and 8 which illustrate a method of making the connector 24 and also show details of the connector. As seen in Fig. 7, proximal ends 68, 70 of the outer and inner tube materials 28, 30 are positioned so that the inner tube material projects outwardly beyond the outer tube material. With this arrangement, a pair of first and second mandrels 74, 76 are engaged as shown in Fig. 8. The first mandrel 76 has a leading cylindrical portion 78 blending outwardly into a converging and generally conical portion 80, which in turn blends into a cylindrical end part 82 angled with respect to the portion 80. The cylindrical portion 78 is engaged in the inner tube material 30 and pushed into place so that there is a slight flaring of this material as it engages on the conical portion 80.

Mandrel 74 is then engaged. This mandrel has an outer cylindrical portion 84 which blends into a converging and generally conical portion 86 ending at a projection 88. This projection has a generally U-shaped configuration and is angled with respect to the
5 conical portion 86.

The projection 88 on the end of the mandrel 74 is shaped to fit the space provided when the inner material 30 is held against the inner surface of the outer tube material 28. (i.e. in the position shown in Fig. 7). As a result there is a generally U-shaped space
10 between the inner and outer tube materials which is filled by the projection 88. The angular offsets of the cylindrical portion 78 of mandrel 76 and the projection 88 of mandrel 74 result in these parts extending axially with respect to the catheter while the cylindrical end part 82 and cylindrical portion 84 of the mandrels diverge at an
15 angle "A" indicated in Fig. 8. These cylindrical parts receive respective intake tubes 36 and 38 which are positioned as shown in Fig. 8. Once the assembly shown in Fig. 8 has been completed, the mould is closed and injection takes place to form the connector 24 shown in chain-dotted outline. This outline of course also
20 represents the cavity of the mould.

The material used for all of the parts is preferably polyurethane, including the moulded connector 24, although other materials can be used provided that the usual requirements of compatibility, etc. are met.

25 After moulding and cooling, the mandrels 74, 76 are removed and because there is flexibility in the material, and because the mandrels are smooth, the mandrels can be pulled out without causing any damage.

It will be evident that this arrangement of connector
30 provides for a smooth transition from the respective intake and return tubes 36, 38 to the respective intake and return lumens 32, 34

(Fig. 2) in the main body of the catheter.

It is significant to note that the angle "A" shown in Fig. 8 can be kept to a small angle in the order of 15 to 20 degrees and is readily maintained below 30 degrees. As a result, the flow into and out of the catheter is essentially axial with reference to the main section 34 at all times. This is desirable in situations where the catheter has to be positioned such that the connecting tubes 36, 38 are as near in line with the catheter as possible.

In a typical catheter to be used for haemodialysis, the inner tube material 28 has an outside diameter of 11.5 French (3.8mm) and a wall thickness of 0.45mm, and the inner tube material has an outside diameter of 6.5 French (2.15mm) and a wall thickness of 0.19mm. The dimensions shown in Fig. 6 are approximately: a = 30mm; b = 4mm; c = 17mm; and d = 13mm. The distance between the ends of the outer and inner tube materials 28, 30 in Fig. 4 is about 6mm and the travel in the RF device 52 is about 25mm resulting in about 2-3mm increase in length.

One possible variation from the preferred embodiment is to arrange for the distal end of the catheter to coincide with the distal end of the transition portion 59 (Fig. 6). However it is preferred to include the tip portion 57.

It is clear that the preferred embodiment described is exemplary of the coaxial lumen catheters generally and that the details and dimensions given are for example only. Such other structures are within the scope of the invention as claimed.

INDUSTRIAL APPLICABILITY

Catheters of the described type are used in medical procedures involving dual flow of body fluid, particularly blood. The catheters are manufactured using established techniques for plastics extruding and forming.

INDEX OF REFERENCE SIGNS

	20	Catheter	22	Main portion
	24	Connector	26	Tip Section
	28	Outer tube material	30	Inner tube material
5	32	Intake lumen	34	Return lumen
	36	Intake tube	38	Return tube
	40	Luer connector	42	Luer connector
	44	Suture wing	46	Collar
	48	Side openings	50	Side openings
10	52	RF Heating device	54	Mandrel
	56	Opening	58	Main portion
	60	Wall	62	Flared entrance
	64	Tapered tip portion	65	Tip portion
	66	Tapered portion	67	Transition portion
15	68	Proximal end	70	Proximal end
	74	Mandrel	76	Mandrel
	78	Cylindrical portion	80	Conical portion
	82	Cylindrical end part	84	Outer cylindrical portion
20	86	Conical portion	88	Projection

CLAIMS

1. A coaxial catheter (20) comprising inner tube material (30) defining a portion of a return lumen (34) extending axially; outer tube material (28) containing some of the inner tube material and spaced radially from the inner tube material to define an intake lumen (32); a transition portion (67) integrally attached to respective inner and outer tube materials forming a smooth continuation axially of said portion of the return lumen (34) and including portions of said inner and outer tube materials; a tip portion (64) extending axially from the transition portion and forming with the transition portion a tip section (26), the tip portion forming a further smooth continuation of said portion of the return lumen (34) and being of said outer tube material (28), the tip portion (64) defining a distal end of the catheter; openings (48) in the outer tube material adjacent the transition portion to provide access into the intake lumen (32); a connector (24) attached to the proximal ends of the inner and outer tube materials (28, 30); and intake and return tubes (36, 38) attached to the connector (24) for continuous fluid communication with the respective intake and return lumens whereby the catheter can be used for procedures requiring dual flow through a single catheter.

2. A catheter as claimed in claim 1 in which the tip section defines at least one further side opening (50) adjacent said distal end of the catheter to permit flow from the return lumen.

3. A catheter as claimed in claim 1 in which the inner lumen (34) is round in cross-section and in which the main portion of the outer tube material (28) is round in cross-section.

4. A catheter as claimed in claim 1 in which the inner tube material (30) has a wall thickness less than the wall thickness of the outer tube material (28).
5. A catheter as claimed in claim 4 in which the inner lumen is round in cross-section and in which the main portion of the outer tube material is round in cross-section.
6. A catheter as claimed in claim 1 in which the connector (24) is trident shaped.
7. A catheter as claimed in claim 6 in which the intake and return tubes (36,38) extend generally axially diverging equally with respect to the axis of the main portion (22) of the catheter.
8. A catheter as claimed in claim 7 in which the angle of divergence the intake and return tubes is in the range of 15 to 30 degrees.
9. A method of making a coaxial dual lumen catheter (20) comprising the steps; providing an outer tube material (28) of a first cross-section and having a selected length; providing an inner tube material (30) of a second cross-section proportioned to fit loosely within the outer tube material, the inner tube material having a length comparable with said selected length; positioning the inner tube material inside the outer tube material, the tube materials being selected so that after this step there is an annular space between the tube materials; placing a mandrel (54) inside the inner tube material; applying heat and pressure to one end of the outer tube material and moving the outer tube material into the heat and pressure to cause some of the outer tube and inner tube materials to flow into one

another about said mandrel to form a tip section (26) of smaller cross-section than said first cross-section thereby defining a return lumen (34) through the inner tube material and tip section, the return lumen being smooth and continuous with a substantially
5 constant cross-section; forming at least one inlet opening (48) in the outer tube material adjacent the tip section to provide flow into an intake lumen (32) defined by said annular space.

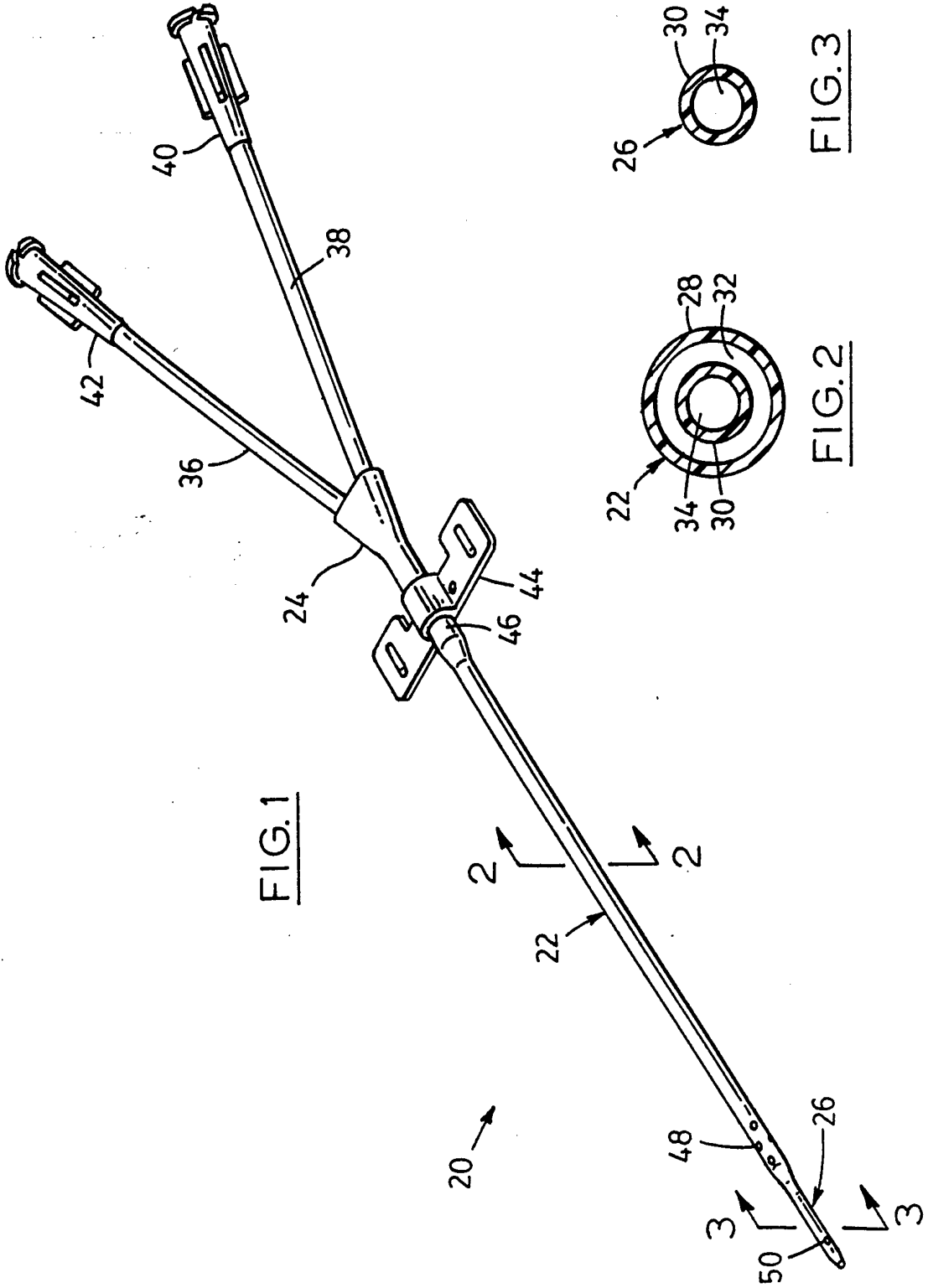

FIG.1

FIG.3

FIG.2

2/3

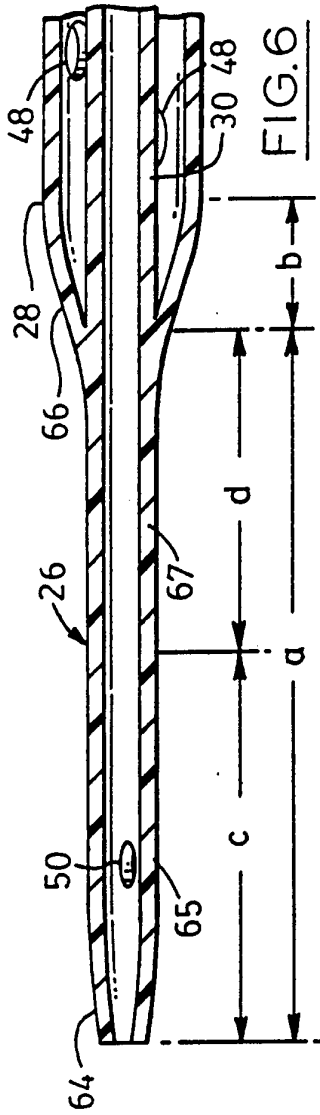

FIG. 6

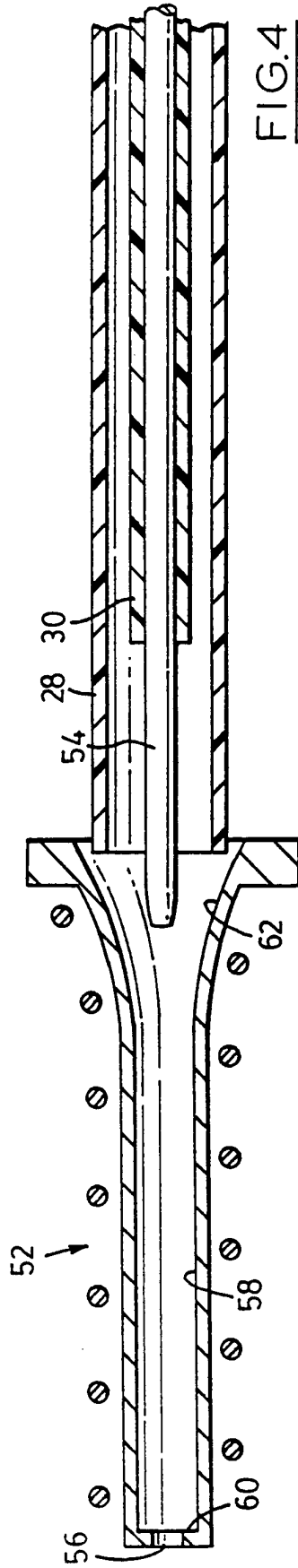

FIG. 4

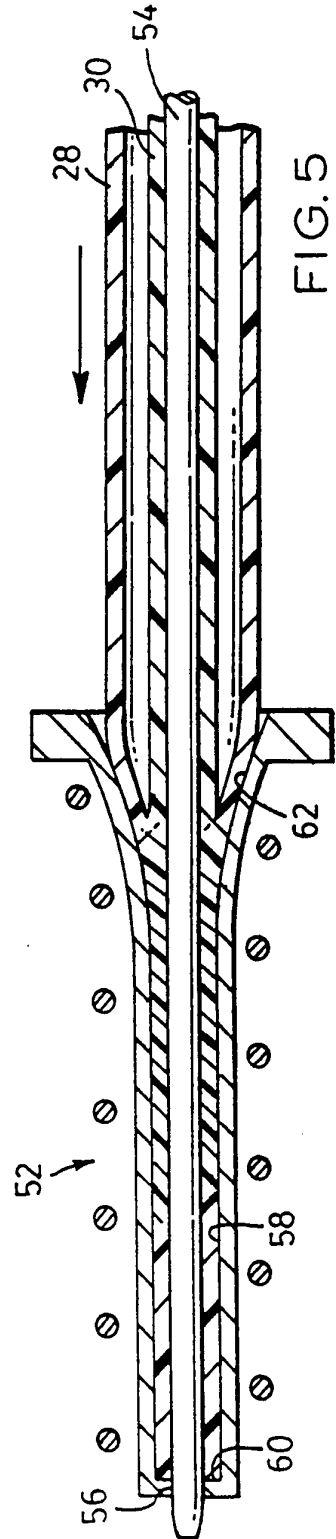
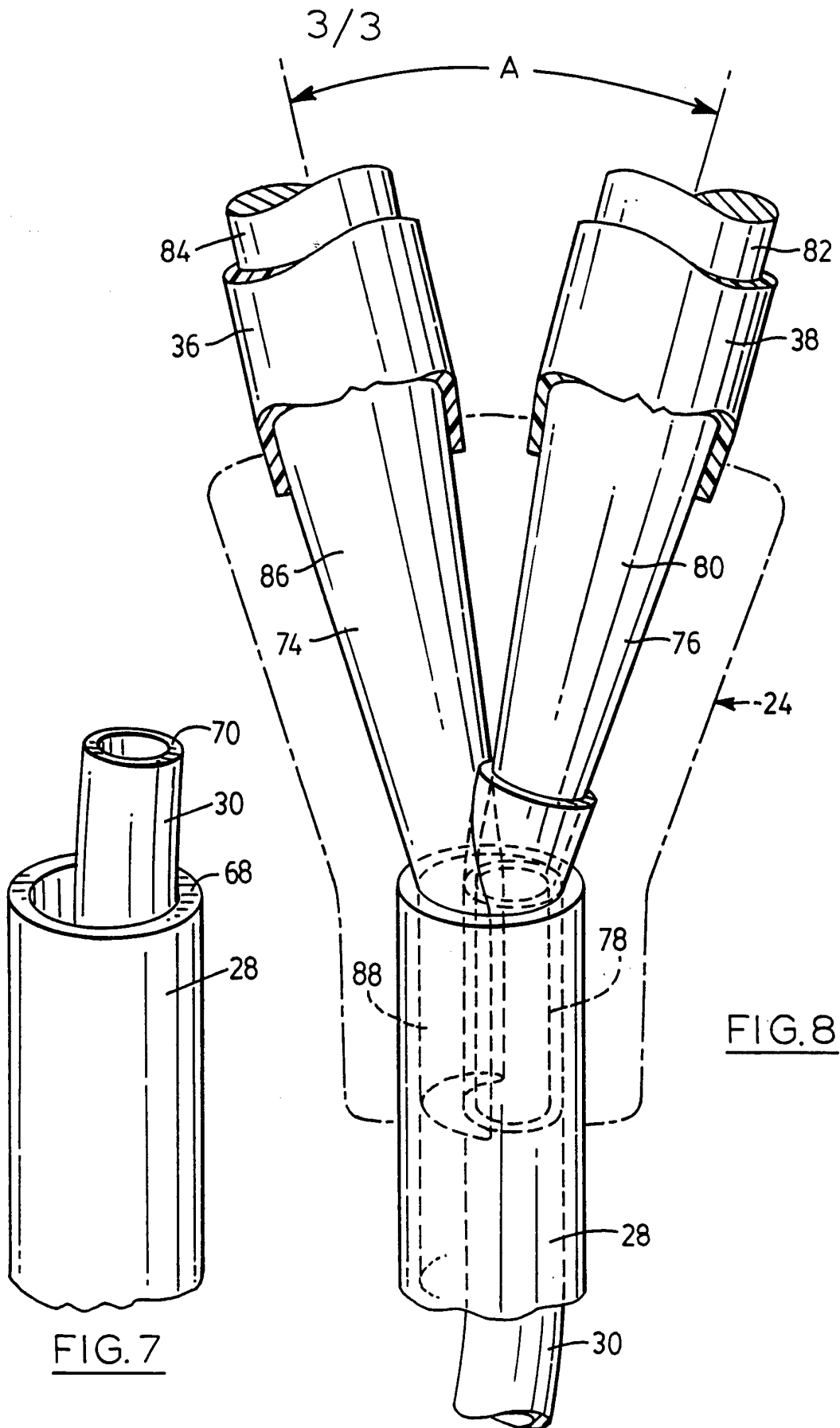

FIG. 5

SUBSTITUTE SHEET



INTERNATIONAL SEARCH REPORT

International Application No

PCT/CA 94/00150

A. CLASSIFICATION OF SUBJECT MATTER
 IPC 5 A61M5/158 A61M25/00

According to International Patent Classification (IPC) or to both national classification and IPC

B. FIELDS SEARCHED

Minimum documentation searched (classification system followed by classification symbols)
 IPC 5 A61M

Documentation searched other than minimum documentation to the extent that such documents are included in the fields searched

Electronic data base consulted during the international search (name of data base and, where practical, search terms used)

C. DOCUMENTS CONSIDERED TO BE RELEVANT

Category *	Citation of document, with indication, where appropriate, of the relevant passages	Relevant to claim No.
X	US,A,5 053 004 (MARKEL) 1 October 1991 see the whole document	1,3-8
Y	---	9
Y	EP,A,0 333 308 (VAS-CATH) 20 September 1989 see column 10, line 17 - column 11, line 54; figures 8-11	9
A	---	1-3,6-8
A	EP,A,0 490 459 (THE KENDALL COMPANY) 17 June 1992 see abstract; figures 1-6	1,3,9
P,X	EP,A,0 535 874 (MED-PRO) 7 April 1993 see the whole document	1-9

Further documents are listed in the continuation of box C.

Patent family members are listed in annex.

* Special categories of cited documents :

- "A" document defining the general state of the art which is not considered to be of particular relevance
- "E" earlier document but published on or after the international filing date
- "L" document which may throw doubts on priority claim(s) or which is cited to establish the publication date of another citation or other special reason (as specified)
- "O" document referring to an oral disclosure, use, exhibition or other means
- "P" document published prior to the international filing date but later than the priority date claimed

- "T" later document published after the international filing date or priority date and not in conflict with the application but cited to understand the principle or theory underlying the invention
- "X" document of particular relevance; the claimed invention cannot be considered novel or cannot be considered to involve an inventive step when the document is taken alone
- "Y" document of particular relevance; the claimed invention cannot be considered to involve an inventive step when the document is combined with one or more other such documents, such combination being obvious to a person skilled in the art.
- "&" document member of the same patent family

Date of the actual completion of the international search

14 June 1994

Date of mailing of the international search report

28.06.94

Name and mailing address of the ISA

European Patent Office, P.B. 5818 Patentlaan 2
 NL - 2280 HV Rijswijk
 Tel. (+ 31-70) 340-2040, Tx. 31 651 epo nl,
 Fax: (+ 31-70) 340-3016

Authorized officer

Kousouretas, I

INTERNATIONAL SEARCH REPORT
information on patent family members

Int. onal Application No
PCT/CA 94/00150

Patent document cited in search report	Publication date	Patent family member(s)	Publication date
US-A-5053004	01-10-91	EP-A- 0472105 JP-A- 4288167	26-02-92 13-10-92
EP-A-0333308	20-09-89	JP-A- 1303159 JP-C- 1761108 JP-B- 4041621	07-12-89 20-05-93 08-07-92
EP-A-0490459	17-06-92	AU-B- 647848 AU-A- 8883591	31-03-94 18-06-92
EP-A-0535874	07-04-93	NONE	