

May 14, 1935.

W. J. MITCHELL
RIG FOR ROTARY DRILLS

2,000,975

Filed June 28, 1933

2 Sheets-Sheet 1

FIG. 1

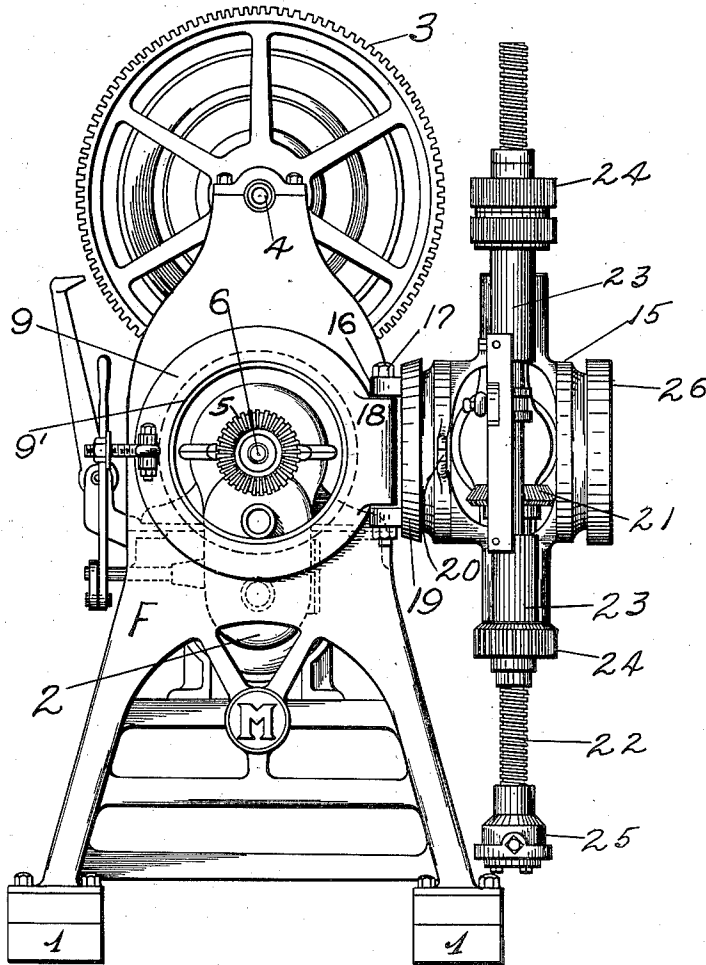

WILLIAM J. MITCHELL
Inventor

334

Herbert S. Smith
Attorney

UNITED STATES PATENT OFFICE

2,000,975

RIG FOR ROTARY DRILLS

William J. Mitchell, San Francisco, Calif., assignor to Chicago Pneumatic Tool Company, New York, N. Y., a corporation of New Jersey

Application June 28, 1933, Serial No. 678,014

3 Claims. (Cl. 255—19)

My present invention relates to an improved rig for rotary drills and it involves particularly the combination with a power unit and drilling mechanism, of a novel hinged, swivel-head coupling, between the power unit and the drilling mechanism.

By the utilization of my invention in the drilling equipment for use either on the ground surface or for subterranean use, the drilling equipment or rig is composed of compactly arranged parts that may readily be adjusted for various drilling operations, as for instance in well boring or drilling, stone boring and other surface operations, as well as for mining and tunneling operations.

The essence of my invention resides in the employment of a hinged, swivel-head coupling between the power unit and the drill-head of the drilling mechanism, and the invention further consists in certain novel combinations and arrangements in connection with the swivel-head and the drill head as will hereinafter be more fully pointed out and claimed.

In the accompanying drawings I have illustrated two forms or adaptations of my invention as examples of the physical embodiments of the invention, one of said adaptations being for surface drilling or boring, and the other form of the invention being for subterranean use. It will be understood however that various changes and alterations may be made in these exemplifying structures, within the scope of my claims, without departing from the principles of my invention.

Figure 1 is a view in elevation of the drilling equipment of my invention adapted for use on the ground surface, as at a well, showing the motor and stationary frame with drive gear in operative position, but with the hinged drill-head and drill supported thereon swung laterally from the frame, to give access to the drilled or bored hole in the ground.

Figure 2 is a top plan view, enlarged, of the drill-head with parts of the drill omitted, and showing in section the swivel head from which the drill head and drill are supported, as in Figure 1.

Figure 3 is a view in elevation of the equipment as used in mining or tunneling operations, where the equipment is supported upon a screw jack.

While the drill rig or equipment, of course, is held in rigid, stationary, position when in use, the parts are readily separable, and as they are comparatively light in weight, the whole equip-

ment is portable and may with facility be transported from place to place when required.

For surface drilling, as in Figure 1 a main, upright supporting frame F is employed and set up on foot blocks as 1 to form a substantial support for the power unit which may include an air motor as 2 having the main power wheel 3 journaled on shaft 4 at the top of the frame.

The driving member for the drilling machine is a bevel gear wheel 5 mounted on the horizontal driving shaft 6, the gear and the shaft being arranged to project through an opening in the main frame as indicated in Figure 2.

The frame F, about the opening through which the drive gear 5 projects, is fashioned as an integral, circular, or annular, swivel-bearing 7, and in this bearing head a complementary, circular, swivel-head 8 is supported, said swivel head having an exterior annular face-flange 9, bearing against the flat face of the frame, and also a tapered seat 9'.

The swivel head 8 is secured in its bearing-head 7 by means of the flange 9 at one side of the frame, and at the opposite side of the frame an attaching ring 10 is secured by bolts 11 to the swivel-head, with the outer rim of this attaching ring overlapping the edge of the bearing head. Thus a substantial, adjustable joint is made between the swivel-head and its bearing-head in order that the former may be turned on its axis, or around the shaft 6 as a center, with relation to the latter, for angular adjustment between the frame and power unit, and the drilling mechanism.

A lock, in the nature of an eye-bolt 12, is pivoted or hinged at 13 on the flange 9 of the swivel-head, and this bolt is provided on its free end with a lock-nut 14, it being understood that the lock bolt is mounted on and moves with the swivel head when the latter is turned for adjustment.

The drill head 15, on which the drilling mechanism is supported, is a hollow structure, as best indicated in Figure 2, and this head is fashioned with a pair of hinge arms 16 spaced apart to provide a wide bearing on the hinge bolt 17 that passes through these arms and also through the long lug 18 of the swivel-head 8, the lug of course being bored to accommodate the bolt 17.

The drill head 15, at one side is fashioned with a tapered or conical bearing ring 19 complementary to the tapered seat 9' of the swivel head 8, and when the drill-head 15 is swung to the left in Figure 2 on its hinge 17, this bearing ring 19 fits snugly into the bearing seat 9' for the purpose of centering the drill head, and its supported parts, with relation to the drive shaft 6 and the drive

gear 5, which as before stated, remain stationary.

Diametrically opposite the hinge bolt of the drill head, the latter is provided with an integral, notched lug 20, which performs the functions of a keeper for the lock bolt 12, and it will be apparent that when the drill-head is closed against the swivel-head these parts may rigidly be locked together by means of the bolt 12, keeper 20 and the lock nut 14 on the bolt.

The driven, bevel gear 21 which transmits the power for the drilling mechanism, is mounted in the drill head in such position that it will mesh with the drive gear 5 when the drill head is closed against the swivel head, and regardless of the angle of adjustment of the swivel head and drill head with relation to the main frame, these bevel gears are in mesh when the drill head is closed against the swivel head.

The bevel gear 21 forms part of the drilling mechanism, together with the feed screw 22 for the drill-spindle, which is supported in bearings 23 of the head, and journaled, as is the driven gear, in bearings integral with or mounted on the drill head. The usual feed-gears 24 are employed for feeding the drilling mechanism, and the drilling tool is connected therewith by means of the centering chuck 25 of the drilling tool.

For alternate uses, the drill head 15 is equipped with a cylindrical swivel-ring 26 disposed in a plane parallel with the plane of the tapered bearing ring 19, and on another side of the drill head, in a plane at right angles to the rings 19 and 26, the head is fashioned with a bevel ring 27, which adapt the drill-head for use in subterranean operations, as in Figure 3. Under these changed conditions the frame F and its motor 2, together with the drill-head, are supported on the screw jack 28 and its lateral arm 29. The free end of the lateral arm is provided with an upright brace or post 30 and clamp 31 to relieve the screw jack of the entire load of the equipment, and to stabilize the equipment.

The bevel ring 27 of the drill head is clamped between jaws 32 on the adjustable clamp sleeve 33, and the latter is adjustable on the lateral arm of the screw jack for centering the bevel ring with relation to its clamping jaws.

The swivel ring 26, shown in dotted lines, is enclosed within a socket-ring 34, and a set of retaining lugs 35 are spaced at regular intervals around the socket ring to retain the drill head on the main frame.

It will be apparent that the drill head may be adjusted on a vertical axis, or swiveled on a horizontal axis, in Figure 3, in order to bring the drilling mechanism supported in the drill head to the desired working position, and the power from the air motor 2 is transmitted through the pitman 36 and crank shaft 4 to the driving shaft 6 and drive gear 5 and thence to the driven gear 21 of the drilling mechanism, as in the first instance. Thus the drilling machine, including the drill-head, is adjustable with relation to the fixed support or jack, to many angles, for the rotary operation of the drilling mechanism, and the screw jack is also adapted for various angular adjustments for various purposes.

Having thus fully described my invention, what I claim as new and desire to secure by Letters Patent is:—

1. In a drill rig the combination with a supporting frame having a bearing ring, a swivel head mounted in said bearing ring and a face flange on said swivel head engaging one side of the bearing ring, a detachable retaining ring on the swivel-head engaging the other side of the bearing ring, a drill-head hinged on the swivel-head, and detachable fastening means for said drill-head and swivel head.

2. In a drill rig, the combination with a supporting frame having a bearing ring, a swivel head having a tapered seat and mounted in said bearing ring, an integral retaining flange on the swivel-head at one side of the bearing ring, and a detachable retaining ring mounted on the swivel head and engaging the opposite side of the bearing ring, of a drill head hinged on the swivel head and provided with a tapered bearing ring to fit said seat, and detachable fastening means for said drill head and swivel head.

3. In a drill rig, the combination with a supporting frame having a bearing ring, a swivel-head having a tapered seat and mounted in said bearing ring, an integral retaining flange on the swivel-head engaging one side of the bearing, a detachable retaining ring engaging the other side of said bearing ring, and bolts securing said retaining ring to the swivel head, of a substantially cylindrical, hollow, drill head hinged on the swivel-head and provided with an exterior tapered bearing ring to fit said seat, and detachable fastening means mounted on the drill-head and swivel head.

WILLIAM J. MITCHELL.