

3 Sheets - Sheet 1.

J. Kirby,

Making Wooden Pins.

No 6,659.

Patented Aug. 21, 1849.

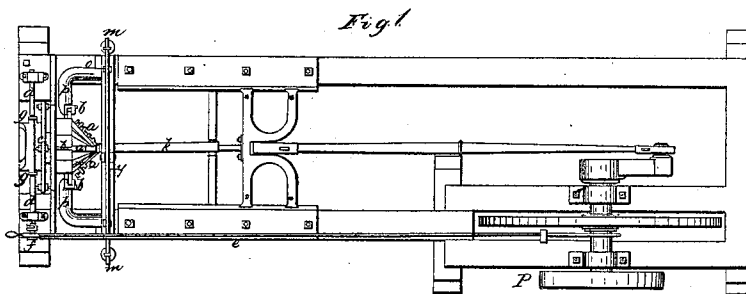
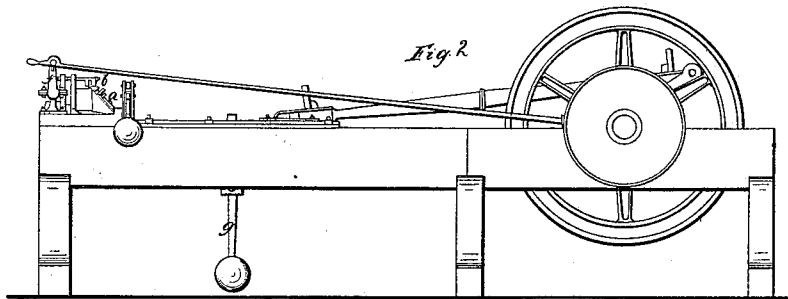
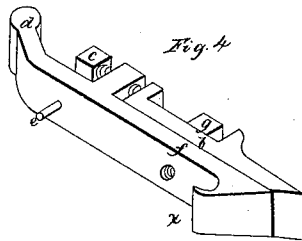
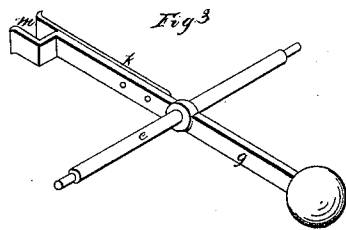

3 Sheets - Sheet 2.

J. Kirby,

Making Wood Pins.

N<sup>o</sup> 6,659.

Patented Aug. 21, 1849.

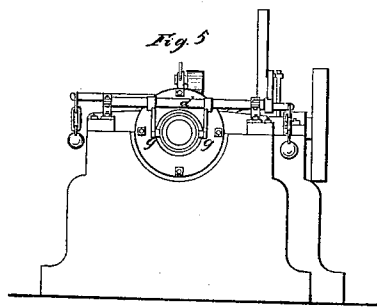
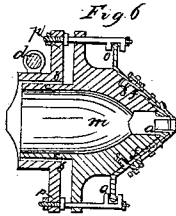
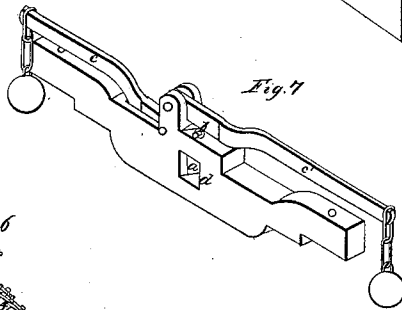
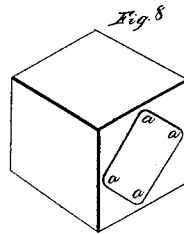

3 Sheets - Sheet 3.

J. Kirby,

Making Wooden Pins.

No. 6,659.

Patented Aug. 21 1849.

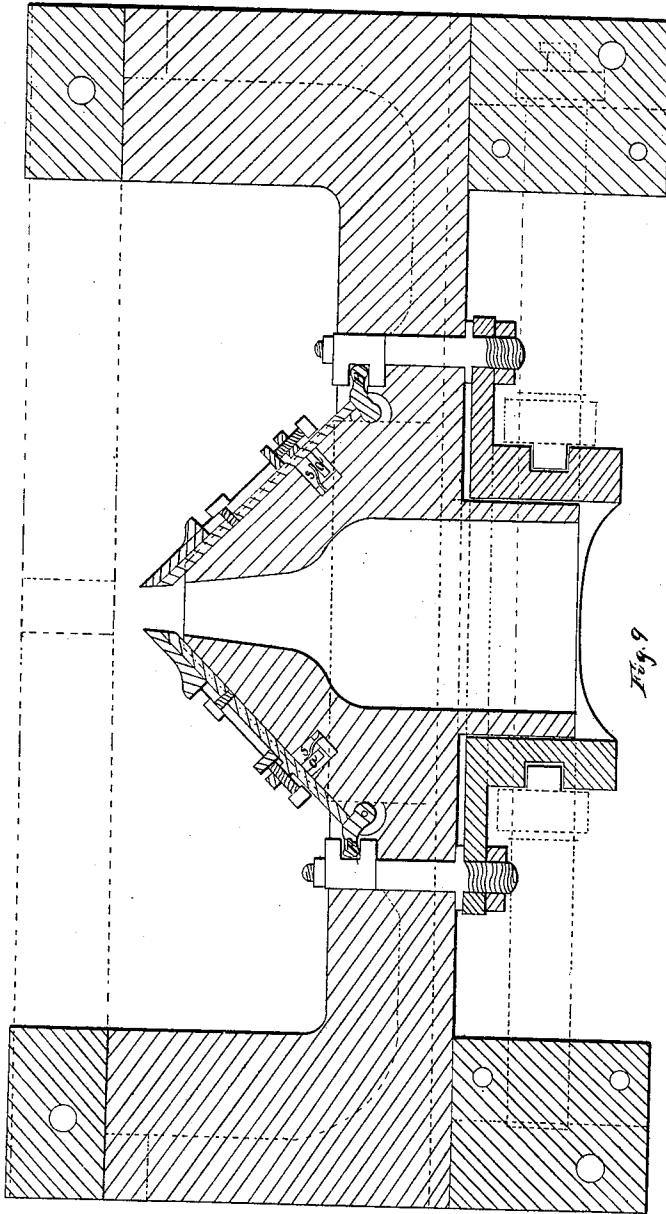

# UNITED STATES PATENT OFFICE.

JOSIAH KIRBY, OF CINCINNATI, OHIO.

## TREENAIL-MACHINE.

Specification of Letters Patent No. 6,659, dated August 21, 1849.

*To all whom it may concern:*

Be it known that I, JOSIAH KIRBY, of Cincinnati, in the county of Hamilton and State of Ohio, have invented a new and useful Machine for Making Treenails for Ship-Building and other Purposes; and I do hereby declare that the following is a full and exact description of the operation and construction of the same, reference being had to the annexed drawings, making a part of this specification.

Figure 1 is a plan or top view; Fig. 2, is an elevation; Fig. 3, a pendulum or rest for the end of treenail, Fig. 4, planing bit on its holder, Fig. 5, end elevation, Fig. 6, perpendicular section of head or bed on which the planing bits are fitted, Fig. 7 guide through which the treenail is forced by pitman from mainshaft, Fig. 8, a plug to be inserted in guide (Fig. 7,) when the pin is being eight squared, Fig. 9, horizontal section of head to a large scale.

The nature of my invention consists in making treenails for ship-building and other purposes by forcing the timber between sharp bits or knives. These bits are arranged on a main head at suitable angles with each other, so as to shave the pin as it passes through the head, square or otherwise. They are also by means of a rock-shaft and slide connections round the head made to close their edges gradually on the treenail as it is forced through between them, at once squaring and tapering it.

To enable others skilled in the art to make and use my invention, I will proceed to describe its construction and operation.

Figs. 1 and 2 of the accompanying drawings, show a plan, elevation of the entire machine, the framework of which may be made to vary in its construction to suit circumstances. Fig. 1 shows the driving pulley, with cam fly-wheel and crank on the same shaft; from the crank proceeds the pitman working T head on which the punch or treenail driver is bolted. The treenail is shown next on the rest from which pendulum is suspended below; the cam-rod working rockshaft, which moves the slide in connection with the planing bits, gives the tapering motion to those bits which the treenail is being forced through. Fig. 3 shows the pendulum and shaft at right angles with it on which it swings, the ends of the shaft having journals which work in

plummer boxes on the sides of frame, so that the fork or rest *m*, is on a line with the bits (planing bits) and punch or treenail-driver.

*h*, represents a spring which forms one side of the fork or rest, and gives way to the rough treenail when pressed down into it; *b*, is a ball of metal which is made so heavy as when the fork *m*, is pushed forward by the stroke of the pitman and punch or driver, it will swing back, and recover the perpendicular position of the pendulum *g* to which it is attached.

Fig. 7 represents the guide which lays transverse on the framework, before the planing bits *a*, *a*, Figs. 1 and 2, and which is bolted down through arms extending from the head and through the framework, so as to give a strong connection between the guide and head on frame. *c'*, *c*, represents levers with weights attached.

*b*, represents a slide-pin passing down through the top of guide exactly over the hole through which the treenail must pass, and its lower end within the square hole is beveled off on the side which the treenail enters so that the superior pressure on the treenail overcomes the inferior pressure of the lever *c'* and weight on the upper end of the slide-pin, but the pressure of the lever *c'* on slidepins is sufficient to steady the motion of the treenail as it passes through the bits. A similar slide-pin to *b*, may be seen at *a*, within the square hole of guide which is pressed horizontally by a knee on the left hand lever *c*, and consequently giving a pressure at right angle to that of the right hand lever *c'*. These two slide-pins therefore serve to press the rough treenail against the two opposite sides of the guide-hole, and when it happens that the rough treenail is not exactly straight (the grain of the wood being crooked from which it is split) the slide-pins accommodate the motion of it in such a way as the shaving or planing bits do not straighten the treenail, but only dresses it to the required size, leaving it with the full strength of its fibers, as well as the straight pin or treenail.

It may be observed here that the timber after being crosscutted into proper lengths is split up into pieces of suitable size for the treenails; and then fed into the machine by placing one end in the mouth of guide, and the other in the fork of pendulum as seen

at *h*, Fig. 1. The timber is then forced through the guide and bits by the forward motion of the pitman, and falls out squared or eight squared as the case may be.

5 The main head is constructed with arms extending out on either side so as to lay on the frame as seen at *p*, *p*, Fig. 1, and then turning at right angles to the front meeting the guide *m*, *m*, which as before stated is  
10 bolted down through these arms; the head also branches off to the rear far enough to receive the pillow blocks, which support the rock-shaft *d*, *d*. The mouth of head is made to any given size, either square or octagon  
15 as the case may be, and running in parallel to a given distance, then rounding out wide as at *m*, Fig. 6, so as to give freedom to the end of the treenail when it is crooked. The head in front is beveled off from the top,  
20 bottom, and sides, to the mouth where the treenail enters, then rounded off into the mouth so as to form a bead on each side as at *a*, *a*, Fig. 6. The bit-holders *f*, *f*, are made to hook on the beads, which serve as a  
25 pivot to each of the bits, when they are made to close on the treenail as it passes through; a groove is also made in the head for each bit to prevent side motion, and they extend along this groove to where the parallel sides  
30 of head begin, and end with a lug or catch, with which the bit-rods connect, as shown at *o*, *o*, Fig. 6. A rim is projected out on the back of the head at *e*, *e*, Fig. 6, on which the flange *b*, *b*, is made to slide. The bit-rods  
35 are bolted to the sliding flange *b*, *b*, at *p*, *p*, Fig. 6, and the motion of the flange from front to rear is produced by the rock shaft, worked by the cam rod *e*, Fig. 1; the connections of the rock shaft with flange is  
40 shown at *g*, *g*, Fig. 5, *d*, being the shaft resting on plummer blocks at each side of the frame; on Fig. 6 *d*, is a section of rock-shaft. *s*, *s*, Figs. 6, and 9, shows a spring riveted fast in a hole in the head which bears against  
45 a pin *e*, Fig. 4, or *a*, *a*, Fig. 9, which projects out from the bottom of bit-holder. The pressure of this spring serves to keep the hook of holder *w*, Fig. 4, hard up against the head at *a*, *a*, Fig. 6, and at the same time  
50 allows the end of the holder to be raised and lowered by the motion of the flange and bit-rods. *a*, *a*, *a*, at Fig. 1, represents the shaving bits on holders arranged for work.

*b*, *b*, *b*, shows the bit-rods grasping the bit-holders, and extending through the permanent flange of head, and bolted firm to the sliding flange, as seen more plainly on Fig. 6.

The edge of the sliding flange is seen at *e*, Fig. 1, *d*, *d*, the rock-shaft; *g*, *g*, the arms of rock shaft, connecting with the sliding flange; *f* the crank of rockshaft, and *c*, the cam-rod which works the rock shaft, when put in motion from the main shaft by a belt on the pulley P.

65 The timber or rough treenail, as seen at *h*

Fig. 1, is forced through the guide and planing bits by pitman, and falls out of the machine squared or finished as the case may be; as it requires two operations to make the treenail, one to square it and another to  
70 eight-square it.

The same motion which forces the timber through the bits is made to operate on the sliding-flange by means of a cam on main shaft, cam-rod, and rock-shaft, thereby  
75 moving the outer ends of bit-holders forward, so as to throw the edges of the bits toward each other, which gives the required taper to the treenail.

The treenail having passed once through  
80 the four planing bits with its sides vertical and horizontal, it is of course only squared and tapered, but as it is necessary to have it eight sided, its sides by some means must be held at an angle of 45° on the rest or pen-  
85 dulum and forced forward through the four planing bits in that position. To effect this a square plug Fig. 8, is inserted in the mouth of guide at *d*, *d*, Fig. 7 (the action of the levers *c*, *c*', being for the time sus-  
90 pended) with a square hole (the corners of this hole is rounded as seen at *a*, *a*, *a*, *a*, Fig. 8, so as to bear hard against the corners of treenail and keep it firm while passing through the bits) in it at the angle of 45°  
95 to its sides, and of such a size as will freely admit the large end of squared treenail, and consequently when the treenail is forced through the bits again, it will fall out eight squared and finished. 100

When the timber is straight, the eight squaring of the treenail can be done at one operation. For this purpose I arrange the cornering bits in the main head on the four sides which are at angle of 45° with the  
105 vertical and horizontal sides on which the four squaring bits are placed, and at a little distance behind the squaring bits to make room for the shaving. The holders of the cornering bits are made to slide in a dove-  
110 tail groove, and are moved together as the treenail passes through by the bit-rods operating on bent levers as seen at B, B, Fig. 9; they are brought back to their places by springs *s*, *s*, which are made to bear against  
115 a pin *a*, *a*, projecting from the bottom of the bit holders. The bits in either plan of moving the holders, are arranged in the same way as shown isometrically by Fig. 4.

Now what I claim as my invention and de-  
120 sire to secure by Letters Patent is—

The combination of the bit with the bit holder and head and the bit rod and flange, constructed and operating substantially in the manner and for the purpose herein de-  
125 scribed.

JOSIAH KIRBY.

Witnesses:

H. J. SPENCER,  
JOHN BRASHEAR.