



(22) Date de dépôt/Filing Date: 2016/07/26

(41) Mise à la disp. pub./Open to Public Insp.: 2018/01/26

(45) Date de délivrance/Issue Date: 2021/05/25

(51) Cl.Int./Int.Cl. *C10L 10/00* (2006.01)

(72) Inventeur/Inventor:
PATTERSON, BRUCE, CA

(73) Propriétaire/Owner:
PATTERSON, BRUCE, CA

(74) Agent: ADE & COMPANY INC.

(54) Titre : MARQUAGE DE CARBURANT A LA TEINTURE

(54) Title: DYE-IT FUEL MARKING

(57) **Abrégé/Abstract:**

A fuel additive injection system for injecting a fuel additive into fuel being delivered through a fuel delivery system. The injection system features a reservoir for containing the fuel additive, a positive displacement pump operably arranged to pump said additive fluid in a predetermined quantity per revolution, a stepper motor operably arranged to drive the positive displacement pump, and a control means configured to receive a pulse signal from a computerized means of said fuel delivery system that is indicative of fuel flow conditions within the fuel delivery system, and to operate the stepper motor responsive to the pulse signal to control pumping of the additive fluid according to those conditions.

ABSTRACT

A fuel additive injection system for injecting a fuel additive into fuel being delivered through a fuel delivery system. The injection system features a reservoir for containing the fuel additive, a positive displacement pump operably arranged to pump
5 said additive fluid in a predetermined quantity per revolution, a stepper motor operably arranged to drive the positive displacement pump, and a control means configured to receive a pulse signal from a computerized means of said fuel delivery system that is indicative of fuel flow conditions within the fuel delivery system, and to operate the stepper motor responsive to the pulse signal to control pumping of the additive fluid
10 according to those conditions.

DYE-IT FUEL MARKING**FIELD OF THE INVENTION**

The present invention relates to systems and methods for administering additives to fuel, and more particularly to such system and methods for adding a dye marker to fuel during dispensing of such fuel from a fuel delivery system.

BACKGROUND

It is known for governmental organizations to use fuel dye for the purpose of marking fuel that has been sold under certain tax exceptions or reductions, whereby the marked fuel can be carefully audited to ensure it is only used in the particular applications qualifying for such tax exceptions or reductions. Fuel dye must be added at particular fuel-to-dye ratios prescribed by government regulation, and so there's a need for improved accuracy in fuel dye injection systems to ensure accurate compliance with such regulations.

SUMMARY OF THE INVENTION

According to one aspect of the invention, there is provided a fuel additive injection system for injecting a fuel additive into fuel being delivered through a fuel delivery system, said additive injection system comprising:

a reservoir for containing said fuel additive;

a positive displacement pump operably arranged to pump said fuel additive from said reservoir in a predetermined quantity per revolution of said positive displacement pump;

a stepper motor operably arranged to drive said positive displacement pump; and

control means operably coupled to said stepper motor to control operation thereof, said control means being configured to receive a pulse signal from a

computerized means of said fuel delivery system that is indicative of variable fuel flow conditions within said fuel delivery system, and to operate said stepper motor responsive to said pulse signal to control pumping of said additive fluid according to said variable fuel flow conditions.

5 According to another aspect of the invention, there is provided a method of injecting a fuel additive into fuel being delivered through a fuel delivery system, said method comprising:

 receiving, by an electronic control means, a pulse signal from a computerized means of said fuel delivery system, said pulse signal being indicative of
10 variable fuel flow conditions within said fuel delivery system;

 based on said received pulse signal, controlling, by said electronic control means, operation of a stepper motor operably coupled to a positive displacement pump that is fed by a reservoir holding said fuel additive and is operable to pump said fuel additive in a predetermined quantity per revolution of said positive displacement pump;
15 and

 directing said pumped additive fluid into fuel being delivered through said fuel delivery system.

BRIEF DESCRIPTION OF THE DRAWINGS

 One embodiment of the invention will now be described in conjunction
20 with the accompanying drawings in which:

 Figure 1 is a schematic diagram of a fuel additive injection system of the present invention.

DETAILED DESCRIPTION

 Figure 1 shows a non-limiting example of a fuel additive injection system
25 of the present invention for injecting a diluted or non-diluted fuel additive or dye

marker (hereafter referred to as dye) into a flow of fuel being dispensed from a fuel dispensing system in conjunction with which the fuel additive system has been co-operably installed. The fuel additive injection system features a reservoir 10 for holding a diluted or non-diluted fuel additive or dye marker (hereafter referred to as dye), a circulating pump 12 installed in the reservoir to agitate the dye while the system is being used, and a level sensor 14 installed in the reservoir to indicate when a low level is noted therein. The dye flows from the reservoir 10 to a shut-off tap 16 and into a filter 18, from which it then flows through a non-drip disconnect valve 20 into a dye-injection unit responsible for controlling flow of the dye into the fuel delivery system that is responsible for delivery of gas or diesel to which the dye is to be added

Housed inside a containment box 22, the injection unit features an injection pump 24 responsible for metered injection of the dye to the fuel, which more specifically is a positive displacement pump (for example, built by Fluid Metering Inc.). As a positive displacement unit, the injection pump 24 is operable to perform metered delivery of a predetermined volume (e.g. measured in nano-litres) of dye per full rotation of the pump. The positive displacement pump 24 is driven by a stepper motor 26, a driver board of which is powered by an inverter, for example at an operating voltage of 24 volts, as provided by a 12-24 volt inverter. Control over the step motor's driver board is provided by a printed circuit board (PCB) 28 equipped not only with the appropriate hardware for electronically controlled operation of the stepper motor 26, but also suitable control software capable of utilizing those electronics to control the flow of the dye over a wide range of fuel flow rates, from zero-flow conditions up to substantial or maximum flow conditions, for example up to 1200

litres per minute, and to maintain accurate control throughout various acceleration/deceleration events that may be occur during handling of a manually operated fuel delivery nozzle through which the fuel and injected dye are dispensed.

5 The PCB 28 is connected to a fuel computer of the fuel delivery system, and from this fuel computer receives a pulse signal indicative of fuel flow within the fuel delivery system. The PCB 28 also receives permissive signals governing whether dye is to be injected during the current fuel delivery operation. In the presence of such permissive signals, the PCB 28 operates
10 the pump-driving stepper motor 26 based on the pulse signal from the fuel computer in order to inject dye to the fuel at the prescribed ratio. The PCB 28 is also configured to count the revolutions of the positive displacement pump 24, from which the amount of dye injected into the fuel in a given operation is calculated based on the counted revolutions and the predetermined quantity of
15 dye known to be expelled from the positive displacement pump per revolution thereof. The PCB 28 also reads the dye level in the reservoir 10 through the level sensor 14, whereby the additive injection system monitors how much dye is left in the reservoir. The PCB will send a shut-down signal to the fuel computer before the reservoir runs dry, thus preventing the pump from injecting
20 air, rather than dye, into the fuel.

 The PCB 28 operates a set of system status lights, of which a green light indicates normal proper operating conditions, a yellow light warns of low dye level in the reservoir, and a red light indicates that a shut-down command has been sent to the fuel computer, whether in response to low dye, pump
25 inaction, over/under voltage, no dye flow, or air in the system. For each dye-

injected fuel delivery operation, the PCB 28 records the fuel delivered, the calculated quantity of dye used, the time and date of delivery, and any fault occurrences.

During operation of the injection unit, the dye leaves the positive displacement pump 24 and enters a flow sensor 29, which ensures that dye, not air, is flowing through the line before leaving the containment box 22 through a non-drip quick connect transition fitting 30. The dye then flows onward to a dye valve 32 (e.g. two-way micro-ball valve) that is installed on a fuel valve (e.g. two-way ball valve) of the fuel delivery system that's operable to select between bulk delivery and hose reel delivery options for the fuel being delivered therethrough. The dye valve 32 is mechanically attached to the fuel valve 34 so that when the fuel valve 34 is turned/rotated to a position directing the fuel to a bulk delivery valve of the fuel delivery system, the dye valve 34 directs the pump-metered dye through a hose to a check valve 38 (e.g. rated one PSI [pound per square inch]) at a terminal connector from which fuel is bulk delivered, where the dye enters this bulk-delivery fuel flow. On the other hand, when the fuel valve 34 is turned/rotated to a position directing fuel to a hose reel 40 of the fluid delivery system, the dye valve 32 likewise directs the dye in the same toward the hose reel 40.

At the hose reel 40, the fuel enters a rotary swivel valve 42 through which the fuel transitions from a stationary pipe of the fuel delivery system to rotating pipe of the hose reel. Here, a swivel device routes the dye line into the fuel flow, and feeds a small dye hose that is situated inside the fuel hose of the hose reel 40. The small dye hose isolates the dye from the fuel, and runs internally along the fuel hose to a check valve 44 (e.g. rated one PSI) situated

at the fuel delivery nozzle on the end of the fuel hose. With the dye only being injected to the fuel at the nozzle, this allows marked fuel delivery and clear (i.e. unmarked) fuel delivery to be performed using the same fuel hose (which can often hold up to 89 litres), without residual dye being left in the hose to
5 contaminate subsequent clear fuel delivery.

Since various modifications can be made in my invention as herein above described, and many apparently widely different embodiments of same made, it is intended that all matter contained in the accompanying specification shall be interpreted as illustrative only and not in a limiting sense.

10

CLAIMS:

1. A fuel additive injection system for injecting a fuel additive into fuel being delivered through a fuel delivery system, said additive injection system comprising:
- 5 a reservoir for containing said fuel additive;
a positive displacement pump operably arranged to pump said fuel additive from said reservoir in a predetermined quantity per revolution of said positive displacement pump;
a stepper motor operably arranged to drive said positive displacement
10 pump; and
control means operably coupled to said stepper motor to control operation thereof, said control means being configured to receive a pulse signal from a computerized means of said fuel delivery system that is indicative of variable fuel flow conditions within said fuel delivery system, and to operate said stepper motor
15 responsive to said pulse signal to control pumping of said additive fluid according to said variable fuel flow conditions.
2. The additive injection system of claim 1 further comprising a circulating pump operably arranged with said reservoir to agitate said fuel additive within the reservoir.
- 20 3. The additive injection system of claim 1 or 2 wherein the control means is further configured to count revolutions of the stepper motor and pump, calculate therefrom an injected amount of fuel additive based on said predetermined quantity per revolution, and then record said injected amount.
- 25 4. The additive injection system of any one of claims 1 to 3 comprising an additive valve linked to a fuel valve of the fuel delivery system for movement

therewith, and arranged to initiate onward flow of the fuel additive from said additive valve into a fuel flow of the fuel delivery system when said fuel flow is initiated by actuation of said fuel valve.

5 5. A method of injecting a fuel additive into fuel being delivered through a fuel delivery system, said method comprising:

receiving, by an electronic control means, a pulse signal from a computerized means of said fuel delivery system, said pulse signal being indicative of variable fuel flow conditions within said fuel delivery system;

10 based on said received pulse signal, controlling, by said electronic control means, operation of a stepper motor operably coupled to a positive displacement pump that is fed by a reservoir holding said fuel additive and is operable to pump said fuel additive in a predetermined quantity per revolution of said positive displacement pump; and

15 directing said pumped additive fluid into fuel being delivered through said fuel delivery system.

6. The method of claim 5 further comprising, by said control means, counting of revolutions of the stepper motor and pump, calculating therefrom an injected amount of fuel additive based on said predetermined quantity per revolution, and recording said injected amount.

20

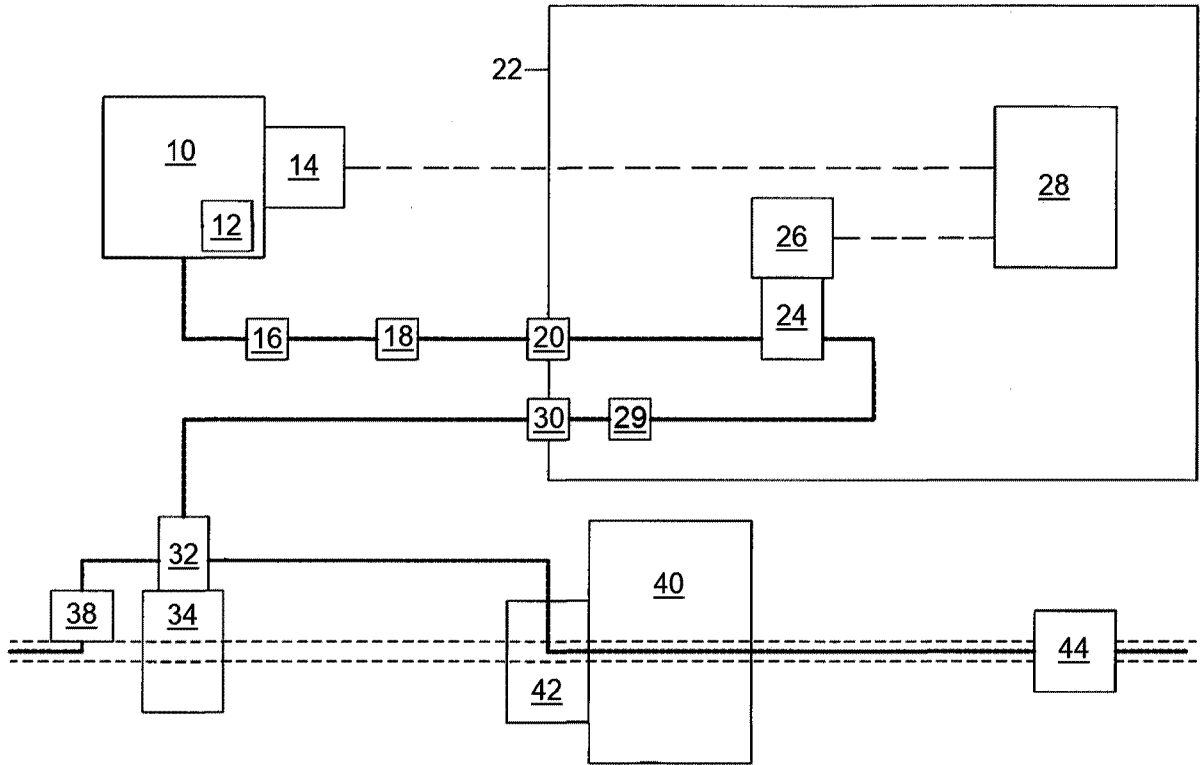

FIG. 1