



(51) International Patent Classification:
B02C 2/04 (2006.01) B02C 25/00 (2006.01)

(21) International Application Number:
PCT/SE2009/051415

(22) International Filing Date:
14 December 2009 (14.12.2009)

(25) Filing Language: English

(26) Publication Language: English

(30) Priority Data:
0802618-9 19 December 2008 (19.12.2008) SE

(71) Applicant (for all designated States except US): SANDVIK INTELLECTUAL PROPERTY AB; S-811 81 Sandviken (SE).

(72) Inventors; and

(75) Inventors/Applicants (for US only): NORRMAN, Percy [SE/SE]; Stora Byvägen 41, S-Landskrona 261 93 (SE). ERIKSSON, Bengt-Arne [SE/SE]; Sveagatan 4, S-233 33 Svedala (SE). GUNNARSSON, Johan [SE/SE]; Köpenhamnsvägen 14A, S-217 43 Malmö (SE). SVENSSON, Kjell-Åke [SE/SE]; Norra Hyllievägen 62, S-216 17 Limhamn (SE).

(74) Agent: HAMMARSJÖ, Joakim; Sandvik Intellectual Property AB, S-811 81 Sandviken (SE).

(81) Designated States (unless otherwise indicated, for every kind of national protection available): AE, AG, AL, AM, AO, AT, AU, AZ, BA, BB, BG, BH, BR, BW, BY, BZ, CA, CH, CL, CN, CO, CR, CU, CZ, DE, DK, DM, DO, DZ, EC, EE, EG, ES, FI, GB, GD, GE, GH, GM, GT, HN, HR, HU, ID, IL, IN, IS, JP, KE, KG, KM, KN, KP, KR, KZ, LA, LC, LK, LR, LS, LT, LU, LY, MA, MD, ME, MG, MK, MN, MW, MX, MY, MZ, NA, NG, NI, NO, NZ, OM, PE, PG, PH, PL, PT, RO, RS, RU, SC, SD, SE, SG, SK, SL, SM, ST, SV, SY, TJ, TM, TN, TR, TT, TZ, UA, UG, US, UZ, VC, VN, ZA, ZM, ZW.

(84) Designated States (unless otherwise indicated, for every kind of regional protection available): ARIPO (BW, GH, GM, KE, LS, MW, MZ, NA, SD, SL, SZ, TZ, UG, ZM, ZW), Eurasian (AM, AZ, BY, KG, KZ, MD, RU, TJ, TM), European (AT, BE, BG, CH, CY, CZ, DE, DK, EE, ES, FI, FR, GB, GR, HR, HU, IE, IS, IT, LT, LU, LV, MC, MK, MT, NL, NO, PL, PT, RO, SE, SI, SK, SM, TR), OAPI (BF, BJ, CF, CG, CI, CM, GA, GN, GQ, GW, ML, MR, NE, SN, TD, TG).

Declarations under Rule 4.17:

[Continued on next page]

(54) Title: GYRATORY CRUSHER WITH ARRANGEMENT FOR RESTRICTING ROTATION

(57) Abstract: A gyratory crusher has a crushing head (22) on which a first crushing shell (30) is mounted, a frame on which a second crushing shell is mounted, and a driving device, which is arranged by means of a rotating eccentric to cause the crushing head (22) to execute a gyratory movement for crushing of material. The crushing head (22) is connected to the frame by way of a rotation-restricting arrangement (40), which comprises a beater (44) in a tank (42). Spinning of the crushing head (22) is restricted by the beater (44) being braked, during operation of the crusher, by a liquid contained in the tank (42).

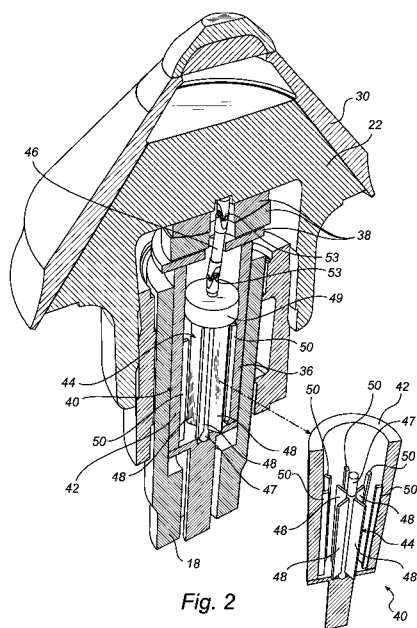

Fig. 2

— *as to applicant's entitlement to apply for and be granted
a patent (Rule 4.17(ii))*

Published:

— *with international search report (Art. 21(3))*

GYRATORY CRUSHER WITH ARRANGEMENT FOR RESTRICTING ROTATION

Technical Field

The present invention relates to a device for restricting spinning in a gyratory crusher, which comprises a crushing head on which a first crushing shell is mounted; a frame on which a second crushing shell is mounted, which
5 second crushing shell defines, together with the first crushing shell, a crushing gap; and a driving device, which is arranged by means of a rotating eccentric to cause the crushing head to execute a gyratory movement for crushing of material that is introduced in the crushing gap.

10 Background Art

A gyratory crusher of the kind stated above can be used for crushing, for example, ore and rock material into smaller size. A problem associated with gyratory crushers of this kind is that on those occasions when no material is being fed to the crusher, the crushing head will eventually start to rotate
15 with the eccentric, which is generally referred to as spinning. If the crushing head is spinning when feed material is again introduced into the gyratory crusher, there is a risk that material will be ejected from the crusher and/or that the crushing shells will be damaged. Moreover, the wear of bearing mechanisms provided between the eccentric and the crushing head can be
20 considerable.

US 3,887,143 discloses an arrangement for restricting spinning in a gyratory crusher. A hydraulic pump is mounted in the frame bottom part of the

crusher with the input drive shaft thereof being connected to the crushing head. The pump is provided with a check valve, which enables it to serve essentially as a hydraulic anti-reverse for the crushing head.

5 A hydraulic pump provided with an anti-reverse is complex and tends to break relatively easily or become clogged by dirt, which may lead to unwanted shutdowns.

Summary of the Invention

10 It is an object of the present invention to provide a gyratory crusher capable of restricting spinning, whereby the above drawbacks associated with the prior art are significantly reduced or completely eliminated.

This object is achieved by a gyratory crusher, which comprises a crushing head on which a first crushing shell is mounted; a frame on which a second crushing shell is mounted, which second crushing shell defines, together with the first crushing shell, a crushing gap; and a driving device, which is arranged by means of a rotating eccentric to cause the crushing head to execute a gyratory movement for crushing of material that is introduced in the crushing gap, the crushing head being connected to the frame by way of a rotation-restricting arrangement, which comprises a beater arranged to rotate in a tank, the tank being adapted to contain a liquid for braking of the rotation of the beater.

20 An advantage of this gyratory crusher is that a robust and simple anti-spin function is obtained. As a result of the simple design of the above crusher, the number of unwanted shutdowns can be reduced.

25 According to one embodiment, the eccentric is arranged to rotate about a central shaft and the rotation-restricting arrangement is located inside the central shaft. This positioning results in a particularly compact design of the rotation-restricting arrangement and does not add to the height of the crusher. Preferably, the centre of the beater is located above the centre of the central shaft, seen in the vertical direction, this position enabling a relatively simple connection to the crushing head as well as to the central shaft.

30 According to one embodiment, the tank has a circular-cylindrical wall, which is provided with at least one protrusion extending towards the beater.

An advantage of the protrusion is that it increases the braking action exerted by the liquid on the beater and reduces the risk of the liquid swirling round in the tank in an undesirable manner due to the rotation of the beater.

According to one embodiment, the beater comprises a beater shaft
5 provided with at least one projecting member, which is to be braked, during rotation of the beater, by a liquid contained in the tank. According to one embodiment, said at least one projecting member can be substantially plate-shaped and can extend from the beater shaft towards the wall of the tank in a plane that is substantially parallel to the extent of the beater shaft. This em-
10 bodiment is particularly suitable for crushers which can be operated in both directions of rotation.

According to a further embodiment, said at least one projecting member of the beater is of arcuate cross-section, as seen in a plane that is perpendicular to the beater shaft. This shape enables different braking effects to
15 be obtained depending on the direction of rotation of the crushing head, which may reduce the braking action of the rotation-restricting arrangement during rotation of the crushing head in the desired direction of rolling engagement associated with operation.

According to one embodiment, the portion of said at least one project-
20 ing member of the beater that is most radially distant from the beater shaft is deflectable, which reduces the risk of damage to the rotation-restricting arrangement when cold starting the crusher, since the viscosity of the liquid can be very high at the time of cold starting.

According to one embodiment, the beater is connected to the crushing
25 head by way of a universal joint shaft, which is provided with at least one universal joint. Preferably, the universal joint shaft is divided into an upper shaft section and a lower shaft section, which shaft sections are rotationally locked together and axially displaceable relative to each other.

Preferably, the rotation-restricting arrangement is adapted to generate,
30 during operation, a braking torque of at least 300 Nm when the crushing head is about to start rotating, i.e. when the crushing head has a speed of rotation relative to the frame of 0 revolutions per second.

According to one embodiment, the crushing head is connected to the rotation-restricting arrangement by way of a torque limiter, which reduces the risk of damage to the rotation-restricting arrangement when cold starting the crusher.

- 5 The present invention makes it possible to provide spinning restriction with fewer mechanical components and/or to improve the operational reliability of said spinning restriction. Further advantages and features of the invention will be apparent from the following description and the appended claims.

10 Brief Description of the Drawings

The invention will be described below by means of embodiments and with reference to the accompanying drawings.

Fig. 1 is a schematic sectional view of a gyratory crusher provided with a rotation-restricting arrangement.

- 15 Fig. 2 is a schematic sectional perspective view of the rotation-restricting arrangement in Fig. 1.

Fig. 3 is a schematic sectional view of a beater and a tank as seen from above.

- 20 Fig. 4 is a schematic perspective view showing an alternative embodiment of a beater and tank.

Figs 5a-b are schematic perspective views showing parts of a further alternative embodiment of a beater and tank, Fig. 5a showing the beater at a normal load condition and Fig. 5b showing the beater at an overload condition.

25

Description of Preferred Embodiments

- Figure 1 illustrates schematically a gyratory crusher 10, which has a frame 12 comprising a frame bottom part 14 and a frame top part 16. A vertical central shaft 18 is fixedly attached to the frame bottom part 14 of the frame 12. An eccentric 20 is rotatably arranged about the central shaft 18. A crushing head 22 is rotatably mounted about the eccentric 20, and thus about the central shaft 18. A drive shaft 24 is arranged to cause the eccentric 20 to rotate about the central shaft 18 by means of a conical gear wheel 26 engaging with a gear rim 28 connected to the eccentric 20. The outer periphery of
- 30

the eccentric 20 is slightly inclined relative to the vertical plane, which is illustrated in Fig. 1a and which is *per se* known in the art. Because of the inclination of the outer periphery of the eccentric 20 the crushing head 22 will also be slightly inclined relative to the vertical plane. The crusher 10 shown in Fig. 5 1 is of the type that is without a top bearing.

A first crushing shell 30 is fixedly mounted on the crushing head 22. A second crushing shell 32 is fixedly mounted on the frame top part 16. Between the two crushing shells 30, 32 a crushing gap 34 is formed, the width of which, in axial section as illustrated in Fig. 1, decreases in the downward direction. When the drive shaft 24 rotates the eccentric 20, during operation of the crusher 10, the crushing head 22 will execute a gyrating movement. A material to be crushed is introduced in the crushing gap 34 and is crushed between the first crushing shell 30 and the second crushing shell 32 as a result of the gyrating movement of the crushing head 22, during which movement the two crushing shells 30, 32 alternately approach and move away from one another. Furthermore, the crushing head 22, and the first crushing shell 30 mounted thereon, will be in rolling engagement with said second crushing shell 32 by way of the material to be crushed. This rolling engagement causes the crushing head 22 to rotate slowly relative to the frame 12 in a direction of rotation that is substantially opposite to the direction of rotation of the eccentric 20. 10 15 20

If no material to be crushed is present in the crushing gap 34, the crushing head 22 will not be in rolling engagement with said second crushing shell 32. Instead, the friction in the bearing mechanism between the eccentric 20 and the crushing head 22 will strive to cause the crushing head 22 to rotate in the same direction and at substantially the same speed as the eccentric 20. Since the speed of rotation of the eccentric 20 is much higher than the typical speed of rotation, during rolling engagement, of the crushing head 22, the crushing head 22 too, unless it is braked in some way, will reach a high speed of rotation when there is no material in the crushing gap 34. Such a significant increase of the rotational speed of the crushing head 22 in a direction of rotation opposite to the direction of rotation during the rolling engagement described above will be referred to below as "spinning". Accordingly, 25 30

when material is present in the crushing gap 34 and the crushing head 22 is in rolling engagement with the second crushing shell 32, the crushing head 22 rotates slowly in a first direction of rotation, which is opposite to the direction of rotation of the eccentric 20. On the other hand, when no material, or only very little material, is present in the crushing gap 34, there is a risk that the crushing head 22, unless it is braked, quickly starts to rotate in a second direction of rotation, which is the same as the direction of rotation of the eccentric 20, which means that the crushing head 22 is spinning. Spinning is undesirable and may result in increased wear of the crushing shells 30, 32 and of the bearing mechanisms of the crusher 10 provided between the crushing head 22 and the eccentric 20. Spinning may also result in the feed material to be crushed being ejected from the feed opening of the crusher 10.

The crusher 10 is provided with a device that reduces the tendency of the crushing head 22 to spin. Such a device will be described below.

The crushing head 22 is supported on a support piston 36, which is hydraulically vertically adjustable inside the central shaft 18 and rotationally locked to the same. The purpose of the vertical adjustability is, *inter alia*, to enable any wear of the crushing shells 30, 32 to be compensated for, but also to allow the width of the gap 34 to be varied, in order to produce crushed material of different sizes. A set of thrust bearings 38, which are arranged between the crushing head 22 and the support piston 36, enables tilting of the crushing head 22 during the gyrating movement thereof. The support piston 36 is connected to the crushing head 22 by way of a rotation-restricting arrangement 40, as is shown more clearly in the perspective view in Fig. 2.

Fig. 2 shows the rotation-restricting arrangement 40, which comprises a tank 42 in the form of a substantially cylindrical space formed inside the support piston 36, and a beater 44, which is connected to the crushing head 22 by way of a mechanical slip clutch 49 and a universal joint shaft 46. The tank 42 contains a liquid, suitably in the form of hydraulic oil or lubricating oil, in which the beater 44 is immersed. When rotating the crushing head 22 the universal joint shaft 46, which is connected to the beater shaft 47 of the beater 44, will cause the beater 44 to rotate in the oil, the viscosity of the oil

braking the rotation of the beater 44 and, thus, of the crushing head 22 relative to the support piston 36.

The purpose of the mechanical slip clutch 49 is to protect the rotation-restricting arrangement 40 against overload damage which might otherwise occur if the viscosity of the oil in the tank 42 is too high before the oil has reached its working temperature, for example when cold starting the crusher in a cold winter climate. Naturally, torque limiters other than the mechanical slip clutch type can be used.

The universal joint shaft 46 is provided with universal joints 53, which enable the universal joint shaft 46, at the point of attachment to the crushing head 22, to move with the gyrating movement of the crushing head 22. The universal joint shaft 46 can also be provided with splines (not shown) or similar ridges extending along the shaft 46, which allow the length of the universal joint shaft 46 to be adjusted to compensate for any heat expansion and wear of, *inter alia*, the thrust bearings 38. In the embodiment shown in Fig. 2, this heat expansion and wear compensation is instead achieved by means of a substantial axial play at the lower end surface of the beater shaft 47.

Fig. 3 shows the tank 42 formed in the support piston 36 and the beater 44 as seen from above. The beater shaft 47 of the beater 44 is provided with projecting members in the form of plate-shaped beater blades 48, which serve to increase the resistance of rotation for the beater 44 in the oil 37 contained in the tank 42. A suitable braking action is obtained if the beater blades 48 have a radial extent, as seen from the beater shaft 47, of at least approximately 2 cm, preferably more than 4 cm. Moreover, for the same reason the beater blades 48 should have an extent, as seen in the longitudinal direction of the beater shaft 47, of at least approximately 10 cm, preferably more than 20 cm. In the shown embodiment, the total area A of the surface projected by the beater blades 48 in the tangential direction of the beater 44 is $A=n*r*h$, where n is the number of beater blades, r is the radius of the beater blades 48 and h is the extent of the beater blades 48 in the longitudinal direction of the beater shaft 47. The total area A of the beater blades 48 projected in the tangential direction of the beater 44 should be at least approximately 60 cm².

Furthermore, the inner wall of the tank 42 is provided with protrusions 50, which serve to prevent the oil from creating a swirling motion in the tank 42 during operation, preserving in this way the resistance of the oil. To limit the occurrence of swirling in an efficient manner the protrusions 50 should

5 have an area, as projected in the tangential direction of the beater 44, of at least approximately 10 cm². The clearance between the beater blades 48 of the beater 44 and the protrusions 50 should be between 1 and 20 mm, more preferred between 2 and 10 mm, to obtain a satisfactory braking action. Moreover, the preferred number of beater blades 48 is between 2 and 10.

10 The preferred number of protrusions 50 projecting from the tank wall is between 3 and 20. The number of beater blades 48 can be even or uneven. Irrespectively of the number of beater blades 48, an even or uneven number of protrusions 50 can be used.

During operation of the crusher, the beater 44 will be braked in the oil

15 37 in the tank 42. The braking action will be essentially the same independently of the direction of rotation of the beater 44. However, the braking action will be largely dependent upon the speed of the beater 44. At low speeds of the beater 44 the braking action will be small, whereas at high speeds a considerable braking action will be obtained. In normal operation of the crusher,

20 i.e. when material is fed into the gap 34 shown in Fig. 1, the crushing head 22, and the crushing shell 30 mounted thereon, will be rotating in rolling engagement with the crushing shell 32 at low speed, typically 0.3 revolutions per second. The crushing head 22 rotates the beater 44 at the same low speed, i.e. 0.3 revolutions per second, which is a speed that will generate a very limited braking action in the tank 42. When no material is being introduced into

25 the gap 34, the crushing head 22 will start to spin, i.e. it will rotate in the same direction as the eccentric 20. The eccentric 20 normally rotates at a speed of approximately 3-8 revolutions per second. As the speed of the crushing head 22 increases as a result of the rotation of the eccentric, for example 0,75

30 revolutions per second, the beater 44 too will rotate faster and faster in the oil 37 in the tank 42. This will significantly increase the braking action exerted on the beater 44 in the tank 42, whereby the beater 44 brakes the rotation of the crushing head 22, thus preventing the crushing head 22 from spinning at the

same speed as the eccentric 20. Conveniently the beater 44 and the tank 42 are designed in such a manner that the speed of rotation of the crushing head 22 is reduced by braking to not more than approximately 2 revolutions per second, more preferred not more than 1 revolution per second, when the eccentric 20 is rotating at top speed. In this way, a robust anti-spin function is obtained.

Fig. 4 shows an alternative embodiment in which a rotation-restricting arrangement 140 comprises a beater 144, which is adapted to rotate in a tank 142 provided with dovetail protrusions 150 and adapted to contain a liquid, for example hydraulic oil. An upper portion of the wall of the tank 142 has been left out in order to show the beater 144 more clearly. A beater shaft 147 is provided with beater blades 148. The beater blades 148 are curved, seen from above, to provide different rotational resistance depending on the direction of rotation. As a result, the rotational resistance for the beater 144 can be lower in the direction of rotation associated with rolling engagement than in the direction of rotation associated with spinning. It will be appreciated that beater blades can be of various other designs, which provide a greater rotational resistance in one direction of rotation than in the other direction of rotation.

Figs 5a and 5b illustrate a rotation-restricting arrangement 240 which comprises a beater 244, which is adapted to rotate in a tank 242 provided with semi-circular protrusions 250 and adapted to contain a liquid, for example hydraulic oil. An upper portion of the wall of the tank 242 has been left out in order to show the beater 244 more clearly. A beater shaft 247 is provided with beater blades 248. The radially outer portions 251 of the beater blades 248 are made of a resilient material, for example rubber, plastic or spring steel. Fig. 5a shows the beater 244 at normal load condition, whereby is meant that the liquid contained in the tank 242 has reached its working temperature and has a relatively low viscosity. Fig. 5b shows the beater 244 at an overload condition, whereby is meant that the gyratory crusher has been started at low temperature, at which the temperature of the the liquid contained in the tank 242 is low, for example 0°C or lower, and the viscosity, therefore, is extremely high. Because of the high viscosity in the case shown

in Fig. 5b the radially outer portions 251 are deflected, which reduces the stress on the beater 244. In this way, operating disturbances caused by damage to the beater 244 due to the high viscosity of the liquid during a cold start are avoided. Accordingly, the deflectable outer portions 251 limit the need for providing a torque limiter at the junction of the beater 244 to the crushing head 22. Once the liquid in the tank 242 has reached the desired working temperature, and thus has a lower viscosity, the outer portions 251 will spring back to the position shown in Fig. 5a, thereby providing normal braking action. Alternatively, the beater blades can of course consist of two or more rigid parts, in which case the deflecting ability is achieved by joining together the rigid parts using springy joints. Furthermore, it will be appreciated that similar results can be obtained if the protrusions 50, 150, 250 projecting from the wall of the tank 42, 142, 242 are bendable, compressible or otherwise arranged to deflect in a springing manner.

It will be appreciated that various modifications of the embodiments described above are conceivable within the scope of the invention, as defined by the appended claims.

Thus, the design of the rotation-restricting arrangement 40 is not limited to that of a rotary beater 44 in a rotationally fixed tank 42. The rotation-restricting arrangement 40 can also have, for example, a rotary tank 42 which is connected to the crushing head and which rotates about a fixed beater 44 connected to the central shaft 18 or to the frame 12, or it can be of any other suitable design. The relative movement of the beater 44 and the tank 42 is not limited to a rotating motion; also linear and other beating motions or combinations of beating motions are conceivable and fall within the scope of the appended claims.

Furthermore, the torque limiter 49 may be of various types; it may be for example a mechanical or hydraulic slip clutch, or a sacrificial component, which is dimensioned to break at an overload condition to spare the beater.

Preferably, the liquid in the tank 42 is some kind of oil, such as lubricating or hydraulic oil, but may also be any other kind of liquid, such as water.

The beater blades can have a shape other than that of the beater blades 48, 148, 248 shown in the Figures. For example, each beater blade may have the shape of an S or a spiral.

5 In the embodiments described above, the rotation-restricting arrangement is shown as arranged on a gyratory crusher of the type that is without a top bearing. Naturally, a rotation-restricting arrangement may well be mounted on a gyratory crusher having a top bearing as well as on other types of gyratory crushers.

10 The disclosures in the Swedish patent application No. 0802618-9, from which this application claims priority, are incorporated herein by reference.

CLAIMS

1. A gyratory crusher, which comprises a crushing head (22) on
5 which a first crushing shell (30) is mounted; a frame (12) on which a second
crushing shell (32) is mounted, which second crushing shell (32) defines,
together with the first crushing shell (30), a crushing gap (34); and a driving
device (24), which is arranged by means of a rotating eccentric (20) to
10 cause the crushing head (22) to execute a gyratory movement for crushing
of material that is introduced in the crushing gap (34),

c h a r a c t e r i s e d in that

the crushing head (22) is connected to the frame (12) by way of a
rotation-restricting arrangement (40), which comprises a beater (44; 144;
244) arranged to rotate in a tank (42; 142; 242), the tank (42; 142; 242) be-
15 ing adapted to contain a liquid for braking the rotation of the beater (44,
144; 244).

2. A crusher according to claim 1, wherein the eccentric (20) is ar-
ranged to rotate about a central shaft (18) and the rotation-restricting ar-
rangement (40) is located inside the central shaft (18).

20 3. A crusher according to any one of the preceding claims,
wherein the tank (42; 142; 242) has a circular-cylindrical wall, which is pro-
vided with at least one protrusion (50; 150; 250) extending towards the
beater (44; 144; 244).

25 4. A crusher according to any one of the preceding claims,
wherein the beater (44; 144; 244) comprises a beater shaft (47; 147; 247),
which is provided with at least one projecting member (48; 148; 248) which
is to be braked, during rotation of the beater (44; 144; 244), by a liquid con-
tained in the tank (42; 142; 242).

30 5. A crusher according to claim 4, wherein said at least one pro-
jecting member (48) of the beater (44) is substantially plate-shaped and ex-
tends from the beater shaft (47) in a plane that is substantially parallel to
the extent of the beater shaft (47).

6. A crusher according to claim 4, wherein said at least one projecting member (148) of the beater (144) is of arcuate cross-section, as seen in a plane that is perpendicular to the beater shaft (147).

5 7. A crusher according to any one of claims 4-6, wherein the portion (251) of said at least one projecting member (248) of the beater (244) that is most radially distant from the beater shaft (247) is deflectable.

8. A crusher according to any one of the preceding claims, wherein the beater (44; 144; 244) is connected to the crushing head (22) by way of a universal joint shaft (46), which is provided with at least one uni-
10 versal joint (53).

9. A crusher according to claim 8, wherein the universal joint shaft (46) is divided into an upper shaft section and a lower shaft section, and said shaft sections are rotationally locked together and axially displaceable relative to each other.

15 10. A crusher according to any one of the preceding claims, wherein the rotation-restricting arrangement (40) is adapted to generate, during operation, a braking torque of at least 300 Nm when the crushing head (22) is about to start rotating, i.e. when the crushing head (22) has a speed of rotation relative to the frame (12) of 0 revolutions per second.

20 11. A crusher according to any one of the preceding claims, wherein the crushing head (22) is connected to the rotation-restricting arrangement (40) by way of a torque limiter (49).

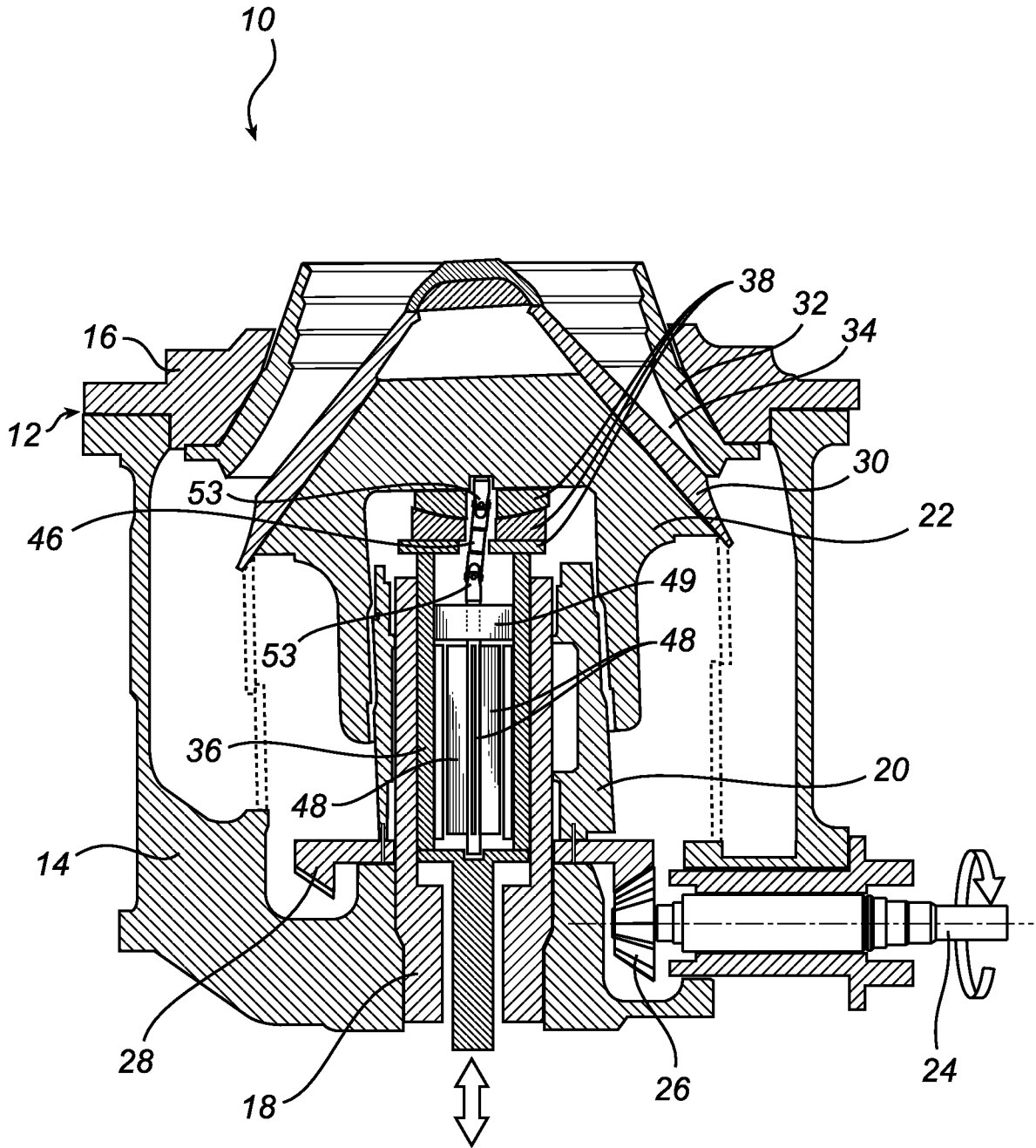
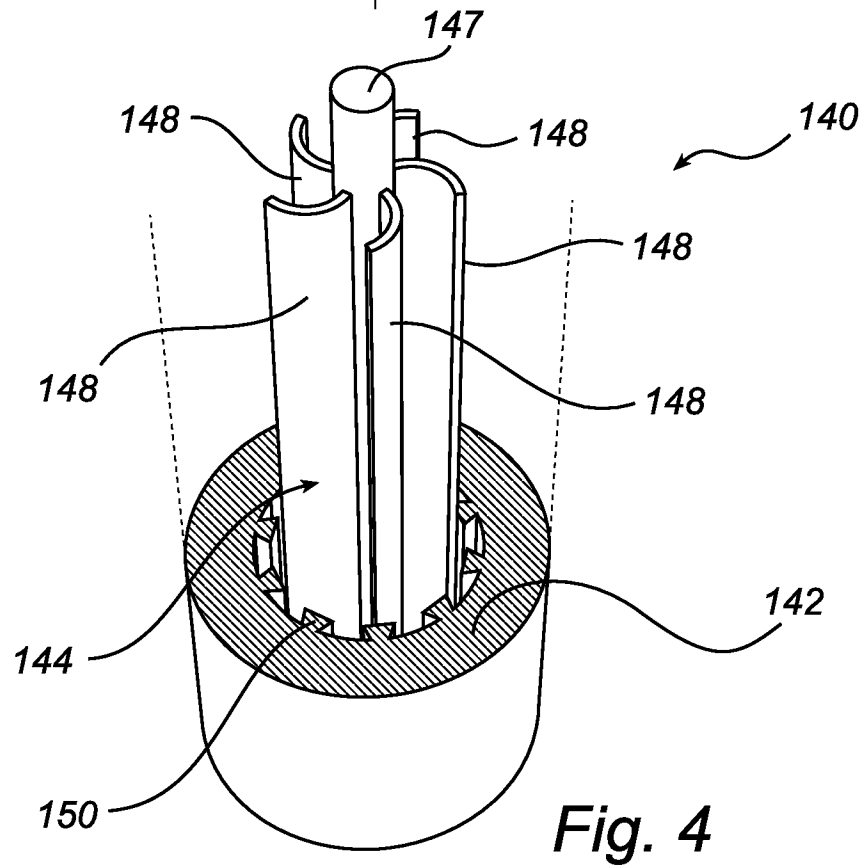
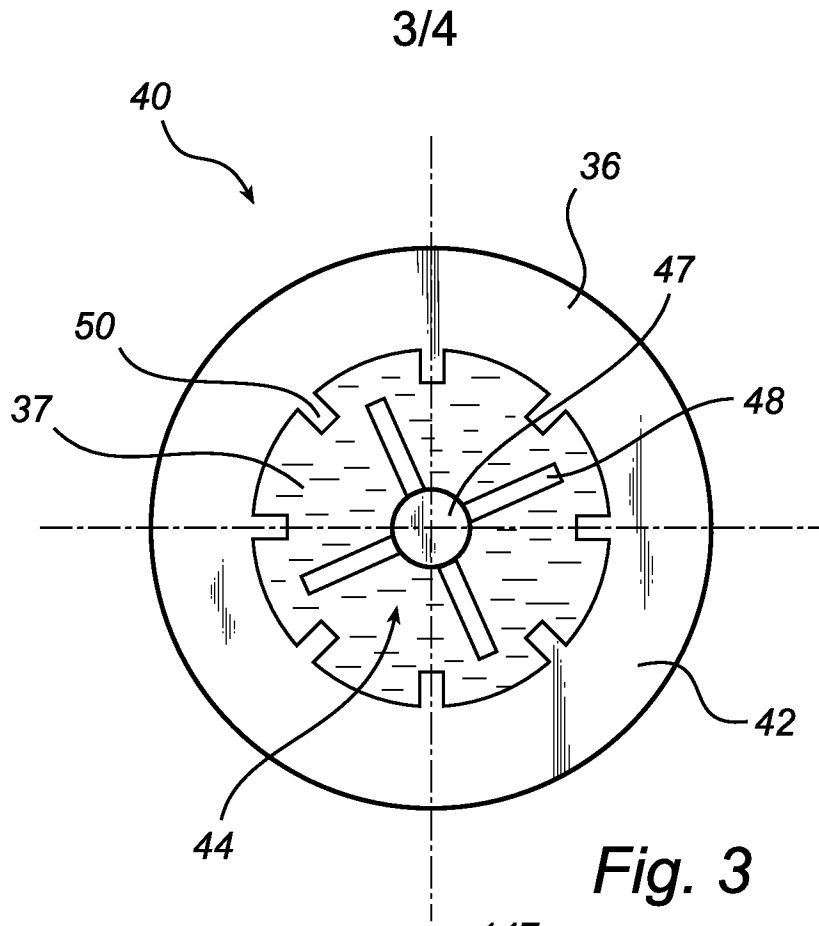

Fig. 1



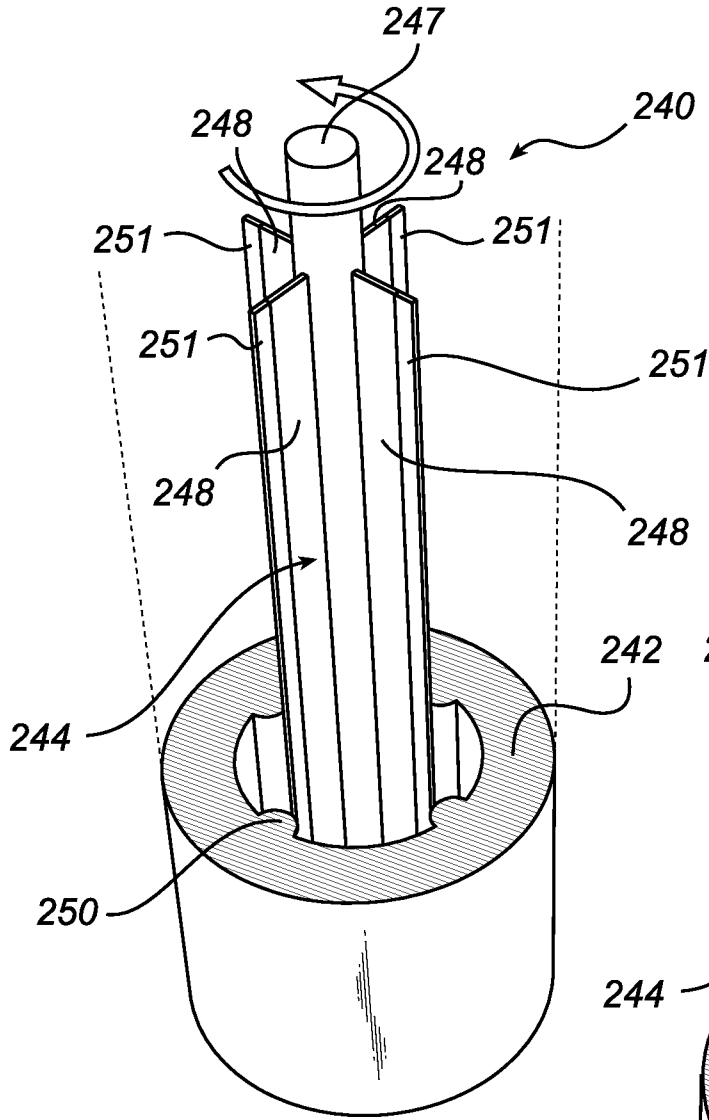

Fig. 5a

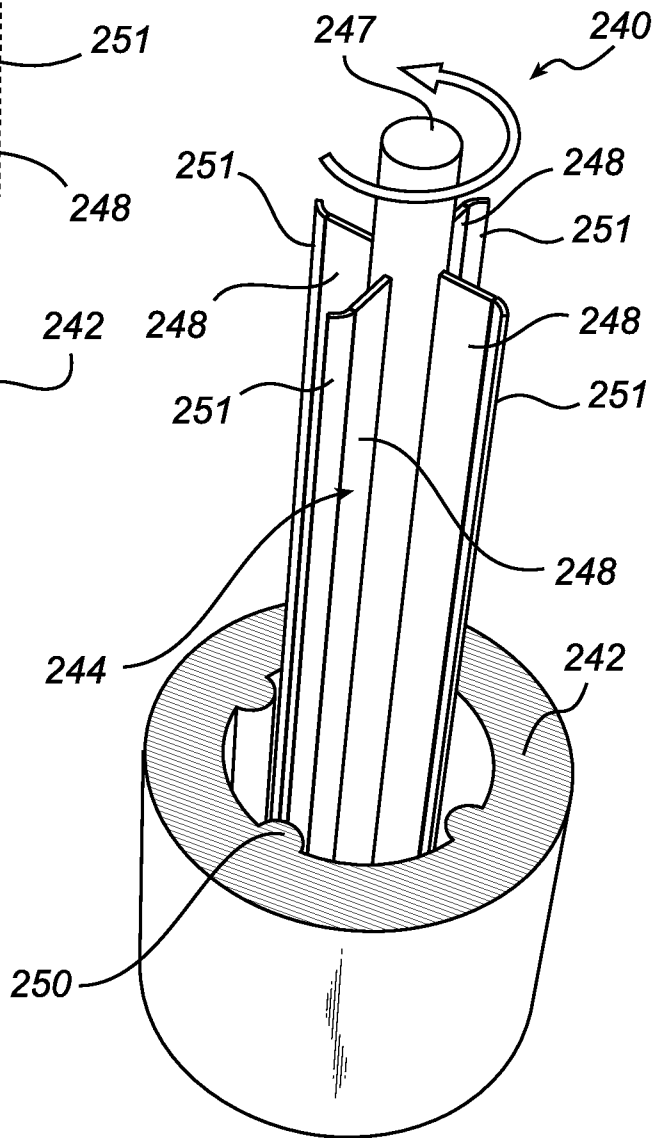

Fig. 5b

INTERNATIONAL SEARCH REPORT

International application No.

PCT/SE2009/051415

A. CLASSIFICATION OF SUBJECT MATTER

IPC: see extra sheet

According to International Patent Classification (IPC) or to both national classification and IPC

B. FIELDS SEARCHED

Minimum documentation searched (classification system followed by classification symbols)

IPC: B02C

Documentation searched other than minimum documentation to the extent that such documents are included in the fields searched

SE,DK,FI,NO classes as above

Electronic data base consulted during the international search (name of data base and, where practicable, search terms used)

EPO-INTERNAL, WPI DATA, PAJ

C. DOCUMENTS CONSIDERED TO BE RELEVANT

Category*	Citation of document, with indication, where appropriate, of the relevant passages	Relevant to claim No.
A	US 4467971 A (L. SCHUMAN), 28 August 1984 (28.08.1984), figure 2, claims 1,7 --	1-11
A	US 5931394 A (M.B. HAVEN ET AL), 3 August 1999 (03.08.1999), column 6, line 65 - column 7, line 38, figure 2 -- -----	1-11

 Further documents are listed in the continuation of Box C.
 See patent family annex.

* Special categories of cited documents:

"A" document defining the general state of the art which is not considered to be of particular relevance

"E" earlier application or patent but published on or after the international filing date

"L" document which may throw doubts on priority claim(s) or which is cited to establish the publication date of another citation or other special reason (as specified)

"O" document referring to an oral disclosure, use, exhibition or other means

"P" document published prior to the international filing date but later than the priority date claimed

"T" later document published after the international filing date or priority date and not in conflict with the application but cited to understand the principle or theory underlying the invention

"X" document of particular relevance: the claimed invention cannot be considered novel or cannot be considered to involve an inventive step when the document is taken alone

"Y" document of particular relevance: the claimed invention cannot be considered to involve an inventive step when the document is combined with one or more other such documents, such combination being obvious to a person skilled in the art

"&" document member of the same patent family

Date of the actual completion of the international search

10 February 2010

Date of mailing of the international search report

17-03-2010

Name and mailing address of the ISA/
Swedish Patent Office
Box 5055, S-102 42 STOCKHOLM
Facsimile No. +46 8 666 02 86

Authorized officer

Katarina Ekman / MRO
Telephone No. +46 8 782 25 00

International patent classification (IPC)**B02C 2/04** (2006.01)**B02C 25/00** (2006.01)**Download your patent documents at www.prv.se**

The cited patent documents can be downloaded:

- From "Cited documents" found under our online services at www.prv.se (English version)
- From "Anförda dokument" found under "e-tjänster" at www.prv.se (Swedish version)

Use the application number as username. The password is **HFRBPVMXMR**.

Paper copies can be ordered at a cost of 50 SEK per copy from PRV InterPat (telephone number 08-782 28 85).

Cited literature, if any, will be enclosed in paper form.

INTERNATIONAL SEARCH REPORT
Information on patent family members

International application No.
PCT/SE2009/051415

US	4467971	A	28/08/1984	NONE
----	---------	---	------------	------

US	5931394	A	03/08/1999	NONE
----	---------	---	------------	------
