



(43) International Publication Date
20 February 2014 (20.02.2014)

- (51) International Patent Classification:
F03B 13/14 (2006.01) *F03B 13/12* (2006.01)
- (21) International Application Number:
PCT/AU2013/000869
- (22) International Filing Date:
7 August 2013 (07.08.2013)
- (25) Filing Language:
English
- (26) Publication Language:
English
- (30) Priority Data:
2012903556 17 August 2012 (17.08.2012) AU
- (71) Applicant: **BOMBORA WAVE POWER PTY LTD**
[AU/AU]; 11 Arlington Avenue, South Perth, Western
Australia 6151 (AU).
- (72) Inventors: **RYAN, Glen Lee**; 11 Arlington Avenue, South
Perth, Western Australia 6151 (AU). **RYAN, Shawn Kay**;
U2/56 McDonald Street, Como, Western Australia 6151
(AU).

(74) Agent: **WATERMARK PATENT & TRADE MARKS ATTORNEYS**; GPO Box 5093, Melbourne, Victoria 3001 (AU).

(81) Designated States (unless otherwise indicated, for every kind of national protection available): AE, AG, AL, AM, AO, AT, AU, AZ, BA, BB, BG, BH, BN, BR, BW, BY, BZ, CA, CH, CL, CN, CO, CR, CU, CZ, DE, DK, DM, DO, DZ, EC, EE, EG, ES, FI, GB, GD, GE, GH, GM, GT, HN, HR, HU, ID, IL, IN, IS, JP, KE, KG, KN, KP, KR, KZ, LA, LC, LK, LR, LS, LT, LU, LY, MA, MD, ME, MG, MK, MN, MW, MX, MY, MZ, NA, NG, NI, NO, NZ, OM, PA, PE, PG, PH, PL, PT, QA, RO, RS, RU, RW, SA, SC, SD, SE, SG, SK, SL, SM, ST, SV, SY, TH, TJ, TM, TN, TR, TT, TZ, UA, UG, US, UZ, VC, VN, ZA, ZM, ZW.

(84) Designated States (unless otherwise indicated, for every kind of regional protection available): ARIPO (BW, GH, GM, KE, LR, LS, MW, MZ, NA, RW, SD, SL, SZ, TZ, UG, ZM, ZW), Eurasian (AM, AZ, BY, KG, KZ, RU, TJ, TM), European (AL, AT, BE, BG, CH, CY, CZ, DE, DK, EE, ES, FI, FR, GB, GR, HR, HU, IE, IS, IT, LT, LU, LV,

[Continued on next page]

(54) Title: WAVE ENERGY CONVERSION

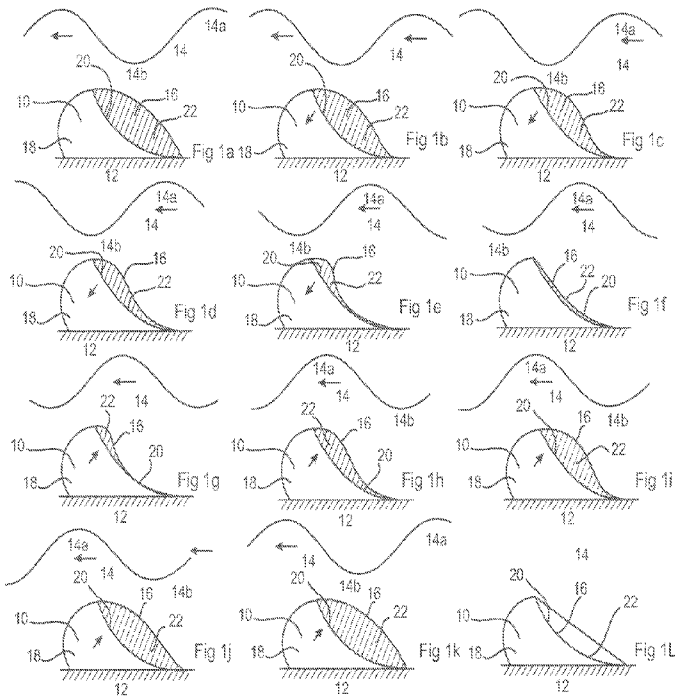

(57) Abstract: A wave energy converter (WEC) (10) has a body portion (18) with a face (20) and at least one flexible membrane (16) bounding at least part of a volume of a fluid to form a variable volume cell (22). The membrane is inclined from vertical providing a flow smoothed passage for wave energy from a wave (14) to travel over the WEC whilst deforming the at least one membrane towards the body to compress the fluid. The cell(s) can be submerged or floating. The inclination of the at least one membrane assists conversion of potential and kinetic energy of the wave to pressure within the fluid. Fluid pressure within the WEC cell(s) and/or system can be optimised to suit wave and/or performance conditions.

WO 2014/026219 A1

MC, MK, MT, NL, NO, PL, PT, RO, RS, SE, SI, SK, **Published:**
SM, TR), OAPI (BF, BJ, CF, CG, CI, CM, GA, GN, GQ, — *with international search report (Art. 21(3))*
GW, KM, ML, MR, NE, SN, TD, TG).

WAVE ENERGY CONVERSION

FIELD OF THE INVENTION

[0001] The present invention relates to wave energy conversion.

BACKGROUND TO THE INVENTION

5 [0002] With present concerns over global warming, carbon emissions and limited access to or availability of traditional fossil fuels, sources of alternative, renewable, energy are becoming more and more important.

[0003] Solar, wind and wave power systems for generating electrical energy are well known. Solar thermal energy systems work well when there is sufficient
10 sunlight, otherwise energy needs to be stored during sunlight hours and released overnight if continuous energy output is required. This is often achieved through phase change salts which liquefy when storing thermal energy and re-solidify when that thermal energy is released. However, if insufficient thermal energy cannot be stored during daylight hours, there is a risk of energy output being
15 exhausted.

[0004] Wind energy obviously requires sufficient movement of air to generate power from wind turbines. Whilst wind turbine technology has progressed and wind energy has become more cost effective, there remains the challenge of intermittency and of siting multiple wind turbines sufficient to generate the
20 required amount of renewable energy. Wind turbines create a visual and noise impact on land that is not always acceptable to locals. Wind farms have more recently been sited out at sea in order to benefit from more reliable prevailing winds and to reduce the environmental impact from the presence of the tall wind turbines.

[0005] The extraction of energy from the seas and oceans is an accepted concept in the field of renewable energy. One major benefit of wave energy is that there is almost always at least some energy to be extracted from waves, thereby making wave energy potentially more reliable than solar thermal or wind energy and more environmentally acceptable in the sense of having lower visual, and potentially lower noise, impact on the local environment.

[0006] Whilst wave energy is relatively straightforward in concept, wave energy is, however, a complex energy medium.

[0007] The energy effectively 'rolls' through the seas and oceans, moving water particles in a circular or elliptical (depending on the depth of the water), oscillating motion (up and down "heave", and back and forth "surge"), relying on the fluidity and viscosity of the water to transmit the energy from one place to another. The water is constantly changing direction both vertically and horizontally and constantly changing in nature from potential (height) to kinetic (motion) energy and combinations in between.

[0008] Waves from seas and oceans are also not regular. While there may be an average period and average wave height at a given location and given time, there will still be variations from wave to wave, and within each wave.

[0009] This all poses a significant challenge to any wave energy converter (WEC) (sometimes called a wave energy conversion device or WECD) trying to extract the energy from the wave. To be efficient, the converter must 'couple' well with the wave (i.e. respond to or 'track' the wave motion) while at the same time resist the wave sufficiently to extract energy from the wave. The converter must also be robust to withstand wave forces, particularly adverse forces during storms, and be efficient with low energy losses, and be cost effective.

[0010] Many different WECs have previously been conceived. However, development of a cost effective converter that is also sufficiently efficient at

extracting energy from the wave and also sufficiently reliable has, as yet, proved elusive.

[0011] Many WECs are very large and 'mechanical' in their construction and operation, resulting in high manufacturing, maintenance and/or operating costs, as well as difficulties in maintaining coupling with the wave due to the high mass and inertia of the converter. This results in low coupling (bandwidth) and poor real world performance.

[0012] Some WECs use relatively complex methods of wave energy capture, transmission and conversion to electrical energy, often progressing through consecutive energy conversions, from wave (fluid) energy to mechanical to hydraulic to rotational mechanical (turbine) to electrical energy. Each stage of conversion has an efficiency and system complexity cost, and leads to energy losses. Each stage of transmission has frictional losses, particularly when working with dense fluids (liquids) under high pressures and velocities such as hydraulics.

[0013] Some converters only focus on one directional component of the energy in the water (i.e. the vertical or horizontal component) and do not try to or effectively capture both vertical and horizontal components or accommodate the fluid nature of the energy flow in waves.

[0014] Other WECs use the oscillating water column (OWC) principle which relies on moving large quantities of water in and out of an open chamber or chambers, that movement pumping air back and forth over a turbine to turn a generator. These OWC converters often require the water to change direction and flow around non-streamlined edges. This increases friction and energy losses in the system and can introduce undue lag which can prevent good coupling with the wave. These converters also require a considerable amount of material in their construction, installation or anchoring, relative to the power output of the converter. The turbine is also exposed to salt laden air which can

increase the cost to resist corrosion and the maintenance cost associated with keeping the blades clean to maintain performance.

[0015] Many WECs are also located offshore and on the surface of the ocean where extremely high forces are evident during adverse weather conditions. This
5 increases the cost of the converter relative to the effective power output.

[0016] One field of WECs that has shown great potential can be characterised as 'membrane' power conversion converters, and more particularly membrane -
pneumatic power conversion converters. These converters use a series of low
cost and low inertia membranes or diaphragms to interact with the wave and
10 efficiently transfer energy to a second fluid, usually a low inertia, low friction fluid
such as air, which transmits the energy onto a turbine and electrical generator.
These WECs can, in general, exhibit better coupling with the wave than other
WECs because of low system inertia (fast response) and due to their reduced
complexity, and have the potential to produce power more cost effectively over a
15 broader range of wave conditions than other types of WEC discussed above.

[0017] Various wave energy converters are discussed in prior patent documents. For example, US 3,353,787 to Semo in the 1960s proposed using water or oil as the second (transmission) fluid. The objective was to have a
sturdy, sub sea converter better able withstand storms and harness a greater
20 proportion of the available wave energy than other more complex converters at
the time. Semo proposed a series of elongated chambers each with a flexible
upper surface to pump an incompressible fluid (liquid) through check valves to a
shore based fluid motor for energy extraction. Flow returned from the shore in
the same circuit as the outflow but entered the chambers through small orifices.

[0018] US 3,989,951 to Lesster in the mid 1970's discusses a submerged
converter using a compressible fluid (such as air) as the transmission fluid to
improve the responsiveness of the converter by reducing the mass and inertia of
the transmission fluid. Lesster also provided for shorter flexible walled cells to

improve the flexibility of operation and had the waves run along the length of the converter over each of the cells in turn. Separate in and outflow circuits, took air from each of the cells via check valves, and led to one or more turbo generators in a closed loop circuit providing a 'push pull' action on the air flow.

5 [0019] US 4,164,383 to French in the late 1970's maintained the longitudinal (spine) design and orientation of the converter facing perpendicular to the wave front. This converter used a closed loop circuit with check valves and air as the transmission fluid but moved the converter to being a floating converter at or just below the surface of the waves like a long 'spine' and used a single flexible
10 enclosure like a bag divided into compartments.

[0020] US 4,375,151 to French in the early 1980's later disclosed control systems using the wave height and multiple closed loop circuits and turbo generators to improve the efficiency of energy extraction by reducing airflow pulsations and improve the converter's sea keeping, particularly pitch control.

15 [0021] US 4,441,030 to Bellamy in the early 1980s discloses a similar floating 'spine' design but in a 'termination' mode i.e. parallel to the wave front, with flexible 'pillow shaped bags' mounted off the side of the spine to capture wave energy and reduce bag wear. The primary focus was on the bag design but this patent document also discloses the use of a single self rectifying turbine per cell
20 rather than the previous closed loop circuits.

[0022] A later patent document US 4,675,536 to Bellamy then progressed in the mid 1980s to a circular or ring design to reduce the size and cost of the converter, improve its sea keeping, and reverting to the option of using a series of membranes but now vertically positioned, rather than bags to capture the wave
25 energy.

[0023] Development of membrane converters then appeared to be stagnant until developments revealed in US 2011-0185721 to Turner and US 2011-

0162357 to Bellamy et al addressed the principle further in 2008. The Turner document focuses largely on a circular converter with an “S” shaped mounting edge for their membrane, and on other design features of the membrane (size, thickness, stiffness, reinforcement etc). Bellamy et al also stayed with a circular
5 converter (or ‘endless spine’) but introduced a combination of membranes and oscillating water columns to the one converter. The objective being to increase the effectiveness and ‘bandwidth’ of the converter (i.e. coupling with the wave) by engaging with the both the heave (vertical) and surge (horizontal) components of the wave energy. Bellamy et al also reverted back to the non-return valve, single
10 directional airflow (closed loop circuit) feature of Lesster, French and to some extent Semo.

[0024] US 7,554,216 to Winsloe and WO 2007/057013 to Rasmussen both disclose oscillating water column (OWC) converters with multiple cells and a closed circuit airflow system using check valves feeding into a high pressure
15 manifold, onto a turbo generator, and returning via a low pressure manifold. Both converters are floating OWC converters and are fully exposed to adverse wave conditions.

[0025] Alternatively, it is desirable of the present invention to provide a wave energy converter (WEC) better able to harness available wave energy than the
20 aforementioned known converters.

[0026] With the aforementioned in mind, it is desirable of the present invention to overcome the difficulties of such converters by preferably providing a sub sea wave energy converter better able withstand storms.

[0027] Alternatively, it is desirable of the present invention to provide a wave
25 energy converter with improved operational efficiency compared with known wave energy converters.

SUMMARY OF THE INVENTION

[0028] With the aforementioned in view, one aspect of the present invention provides a wave energy converter (WEC), including a body portion and at least one flexible membrane bounding at least part of a volume of a fluid, a substantial portion of the at least one membrane inclined from vertical providing a flow
5 smoothed way for wave energy to travel over the WEC whilst deforming the at least one membrane towards the body to compress the fluid, the inclination of the at least one membrane assisting conversion of potential and kinetic energy of the wave to pressure within the fluid.

[0029] A further aspect of the present invention provides a wave energy converter
10 (WEC), including a body portion and at least one flexible membrane forming at least part of at least one cell volume for pressurised fluid, the at least one membrane inclined from a lower portion to an upper portion thereof to allow a wave impinging on the WEC to flow over the at least one membrane and forces from surge and heave of the wave to deform the at least one membrane towards
15 the body to compress the fluid in the at least one volume.

[0030] The WEC according to the present invention converts energy from a wave flowing over the membrane(s) of the WEC to pressure (energy) within one or more volumes of fluid in the WEC that is then able to be harnessed as useful energy. The WEC having the inclined membrane(s) couples with the wave
20 efficiently.

[0031] The flow smoothing may provide a guide for the wave or wave energy over the WEC.

[0032] Preferably, for a vertical cross section through the WEC, a length of
25 the cross section of the membrane is substantially the same as a length of a cross section of a surface of the body or face bounding the cell or volume. This allows the membrane to overlay onto the body surface or face when the membrane is fully deformed or compressed to the body or face.

[0033] The WEC may include at least one port, preferably provided at or adjacent the upper rearward portion of the respective cell. When wave pressure higher than the pressure of the fluid within the cell volume impinging against the membrane causes deformation of the membrane towards the face, the
5 pressurised fluid is forced out of the cell via the at least one port at or adjacent the upper rearward portion of the respective cell.

[0034] The body may include at least one face respectively opposed to one or more of the at least one flexible membrane such that a respective flexible membrane is deformed or deformed by force of an external wave towards the
10 respective opposed face.

[0035] The at least one flexible membrane may deform progressively from the lower forward portion to the upper rearward portion towards the body.

[0036] An alternative aspect of the present invention provides a wave energy converter (WEC), including a body portion and at least one cell, each said cell
15 defined at least in part by a flexible membrane and an opposed face, the respective flexible membrane and face providing a volume for a pressurised fluid within the cell, the flexible membrane deformable towards the face by external force from a wave on the membrane to thereby force the fluid out of the cell via at least one port, wherein, wave pressure higher than the pressure of the fluid within
20 the cell volume impinging against the respective flexible membrane causes deformation of the membrane towards the face

[0037] A further aspect of the present invention provides a wave energy converter (WEC), including a body portion and at least one cell, each said cell defined at least in part by a flexible membrane and an opposed surface, wherein, for a
25 vertical plane through the cell the length of the curve of the membrane cut by the plane is substantially the same as the length of the curve of the face cut by the same plane.

[0038] Another aspect of the present invention provides a wave energy converter (WEC), including at least one cell comprising a body portion and a flexible membrane, the membrane and body portion providing a volume for a pressurised fluid within the cell, the flexible membrane deformable towards the
5 body when the wave pressure impinging against the membrane is higher than the pressure of the fluid within the cell to thereby force the fluid out of the cell via at least one port, and the flexible membrane deformable away from the body when the wave pressure impinging against the membrane is lower than the pressure of the fluid within the cell to thereby force the fluid into of the cell via at least one
10 port, the body portion and or the membrane being shaped in a smooth, streamlined manner.

[0039] The term wave energy converter (WEC) used in relation to the present invention in this specification encompasses a single cell wave energy conversion device, a multi cell wave energy conversion device, combinations of single and
15 multi cell wave energy conversion devices, and such wave energy conversion devices applied to wave energy conversion systems incorporating additional components, such as electricity generating equipment, turbines, pumps, desalination systems and control valves.

[0040] At least one embodiment of the present invention provides a wave
20 energy converter (WEC) that, in use, converts energy fluctuations in a wave of one fluid (typically water) to energy fluctuations in another fluid (typically air) and subsequently onto a power take off converter, such as a turbine, and onto a generator, preferably for the production of electricity.

[0041] The wave energy converter may include one said cell or cells. Multiple
25 such cells may be rigidly attached to one another or form in a single unit to form the converter as a multi cell unit. The cells may be arranged in linear arrays to form a single WEC. Multiple such arrays may be configured into a multi WEC to form a combined converter, such as having two or more linear arrays of WECs. One or more seal may be provided in joins between supply/return conduits of

adjacent WEC cells when connecting multiple discrete WECs together to form a large multi cell WEC, such as having a cast multi cell body.

[0042] The membrane may be a single layer material, or may be multi-layered or laminated, and may be reinforced or incorporate reinforcement.

5 [0043] Preferably the membrane is a non porous membrane. The membrane acts to separate the two fluids (the external fluid carrying the wave action and the internal fluid within the cell) to transfer the energy from the external fluid to internal fluid. This occurs when the pressure on one side of the membrane is higher than the other, and provides a very cost effective, low inertia and
10 responsive way to extract and transmit energy from the wave.

[0044] The converter may include a number of adjacent cells, each with its own membrane.

[0045] The converter is arranged and configured to be sympathetic to the 'rolling' motion of a wave and to progressively extract energy from both the
15 vertical (heave) and horizontal (surge) components of the wave energy as the wave passes across the converter.

[0046] The converter may preferably be anchored under its own weight or otherwise attached to the seabed. For example, the converter may be concreted to the seabed or may be attached to raised supports, a platform or foundations
20 attached to the seabed, or may be self-weighted through geo-textile bags or filled (such as sand filled) internal voids. The wave energy converter might be raised from the seabed to tailor operation of the converter to the prevailing weather and location conditions. For example, where the seabed is particularly uneven or rocky, it may be preferably to raise the converter off the seabed to avoid needing
25 to excavate a large amount of rock. Also, if the marine habitat is sensitive, raising the converter from the seabed can avoid disturbance to marine habitats, flora and fauna, as well as positively create a safe haven habitat below the converter.

[0047] The WEC of the present invention may preferably be located below the mean still water surface, preferably on the seabed in 2.5 to 15m of water.

[0048] The WEC of the present invention is preferably a near shore submerged, pneumatic, attenuation type WEC, but can also be adapted to an
5 offshore submerged or semi-submerged deep water application or fitted to a breakwater.

[0049] According to at least one embodiment of the present invention, each cell may be configured with the rolling action of wave motion in mind and in a manner that the wave energy can smoothly interact with and roll over the
10 converter while the converter extracts energy from the wave. The wave energy converter may have a streamlined front, much like an aerofoil, that smoothly interacts with the impinging wave, preferably slowing it, and transferring some of the surge motion (i.e. the flow towards the converter), to heave (i.e. flow above the converter) increasing the pressure against the membrane as the wave
15 approaches or passes overhead. Pressure against the membrane may be provided by a dynamic pressure front leading the motion of the wave as the wave approaches the wave energy converter. Dynamic pressure can be understood to be a combination of pressure due to the kinetic energy and potential energy of particles in the wave. Thus, there is always some water pressure against the
20 membrane when submerged, and that pressure is dynamic i.e. changes with changes in kinetic and potential energies in the wave.

[0050] A rear of the converter may include a curved or rounded portion (such as a curved or rounded rear face or upper corbel portion). This helps to control return flow of the water over the converter, accentuating the reverse heave and
25 surge effect to create higher velocities and lower pressures above the membrane as the water particles return in their oscillatory motion during a wave trough. This allows the converter to act in a smooth push-pull pumping action as the water passes back and forth overhead to increase extraction of energy from the wave whilst reducing disturbance, loss or friction to the wave motion, minimising
30 unnecessary forces acting on the device.

[0051] In effect, the WEC of the present invention acts in a flow smoothed or streamlined manner (somewhat like an aerofoil) to smoothly interact with and allow the wave motion to be guided over the WEC whilst maximising energy extraction by converting surge to heave as the wave first impinges on the
5 membrane and progresses over the converter. Then as the wave trough passes over the converter the wave flow assists return of the membrane ready for the next wave action. As the trough of the wave advances to pass over the WEC, reduced external pressure is applied to the membrane compared with the higher external pressure caused by the wave at its peak. This lower pressure
10 associated with the trough is lower than the average wave pressure such that the external pressure is lower than the pressure within the cell, thereby causing the membrane to reinflate ready for the next wave.

[0052] Each membrane of each cell may also be configured in a streamlined manner that is sympathetic to the wave motion. Being flexible, the membrane
15 can react to the pressure from or leading the wave and thus deform as the wave motion approaches, moves over, against and around it, extracting the maximum amount of energy from the wave to the fluid within the cell with the minimum of unnecessary disturbance, loss or friction to the wave motion.

[0053] By minimising the level of unnecessary disturbance, loss or friction to
20 the wave motion, the converter minimises the unnecessary forces acting on the converter and reduces the structural and foundation strength required, particularly during adverse weather conditions. By submerging the wave energy converter below the surface of the water, slamming forces of a wave against the wave energy converter are reduced thereby allowing structural and foundation strength
25 to be correspondingly reduced. This is particularly beneficial during adverse weather conditions.

[0054] The combination of these features creates an efficient, low inertia, responsive and cost effective wave energy conversion converter.

[0055] As expressed above, each cell may form part of an individual unit or may be a sub part of a larger structure containing multiple said cells.

[0056] One or more forms of the present invention may be configured as V or chevron format. Preferably each 'limb' ('arm'/'leg') of the V or chevron includes
5 one or multiple said cells.

[0057] Preferably, the apex of the V or chevron may be oriented towards or to face the direction of the oncoming waves i.e. open water sea/ocean oriented (ocean oriented), and the limbs (arms or legs) of the V or chevron extending away from the apex towards the shore such that the waves approach the apex first and
10 the V or chevron and each arm/leg obliquely e.g. at an angle less than 90°.

[0058] The V or chevron arrangement may be reversed such that the apex points towards the shore and away from the waves, such that the limbs of the V project away from the apex towards open water (Shore oriented).

[0059] The included angle of the V or chevron may be substantially or
15 approximately 90°, but may range from 10° to 180° (180° providing a linear array). More preferably the angle may be between 45° and 120°.

[0060] The open water (e.g. sea or ocean) orientated apex better suits those sites more likely to experience significantly adverse wave events by allowing the waves to encounter the apex first and 'peel down' the arms/legs of the converter
20 and then shed excess wave energy into clean water off the end of the arms/legs.

[0061] The Shore orientated apex variant concentrates excess wave energy towards the centre (apex) of the converter which offers greater conversion efficiencies in light seas.

[0062] One or more embodiments of the present invention may be configured in an open curve or arc orientated either towards the ocean with the open side towards shore (convex) or with the open side towards open water (concave).

[0063] These combined features cause the wave energy to concentrate and
5 roll down the legs of the converter(s)

[0064] One or more embodiments of the present invention may be configured in a single spine arrangement. For example, the converter including a longitudinal array of the cells such that each cell is adjacent another to receive an impinging wave. Preferably the spine has an axis at an angle to the direction of
10 the waves, preferably of between 10° and 80° and more preferably between 30° and 60° .

[0065] One or more embodiments of the present invention may be configured as a semi-submersible option (i.e. floating and tethered but not mounted directly onto the ocean floor), preferably in a circular or annular configuration to accept
15 omnidirectional wave spectra typically associated with deep water locations. Thus, where waves may impinge on the converter from various directions over time, a circular or annular arrangement is considered beneficial in order to maximise average wave action rather than the converter being linear and therefore more directional. Such an embodiment could be configured around
20 another structure in the sea/ocean, or provide support for another structure, such as a wind turbine, oil or gas rig, or channel marker. The WEC may be formed as a quadrilateral i.e. two chevron or four linear arrays joined together. Other shapes are considered to fall within the scope of the present invention, such as hexagonal i.e. three chevron arrangements or six linear arrays, or combinations
25 thereof. Embodiments of the present invention may include multi sided WECs. Such multi sided WECs may have an odd or even number of sides. All or a number of the sides may include one or more WEC arrays or cells. For example, a WEC may be 6,8,10,12 sided, with some or all of those sides incorporating cells or arrays of cells. The cells may be on one or both faces of a WEC (i.e. wave
30 facing and facing away from the prevailing wave).

[0066] Selection of the location and orientation of the WEC of the present invention is a function of the installed location and wave resource characteristics (usually due to prevailing wind, water depth, seafloor angle compared to mean water surface level, and tide conditions). In all configurations the intent is to
5 enable the wave to smoothly interact with the converter.

[0067] The membrane may be attached to a body of the converter. The body may also form or include a face against which the membrane preferably sits when not inflated. For example, the body may be formed of one or more cast or moulded portions, such as concrete or plastic or fabricated from steel. The face
10 may be formed of a curved section of the body, preferably integrally formed by casting or moulding as part of the body), or may be a shaped rigid or semi rigid face liner attached to the body to form a desired profile.

[0068] One or more ends of the respective membrane, particularly in an array arrangement with single or multiple cells or chambers, could be form a semicircle,
15 arc or spline, that is either in or out of plane with the inclination plane, with a membrane that has a domed like shape which will utilise either the elastomeric properties and stretch or be geometrically shaped such that the elastomeric strain/stress is reduced.

[0069] The membrane may be attached to the body adjacent upper and lower
20 portions of the body of the converter. When the cell contains pressurised fluid (such as pressurised air) sufficient to overcome exterior pressure (such as from the water in which the converter may be submerged) and 'inflate' the membrane, the membrane curves outwards towards the exterior fluid (e.g. the seawater). The frontal curve or 'face' of each cell membrane may preferably take on an
25 overall streamlined shape, such as a concave or 'catenary' shape or near catenary shape, a domed, inverted catenary, 'S' or similar shape in profile or section. Hydrostatic forces may vary this shape i.e. in addition to the tension and gravity forces acting on the membrane. The membrane may therefore not be perfectly smoothly concave.

[0070] A visualised chord of such a catenary may be inclined at an angle to horizontal (chord angle), such as between 0° and 90° , and more preferably between 20° and 60° , and more preferably $30^\circ \pm 15^\circ$.

[0071] Breakwater installations of the WEC of the present invention may have a shorter foot length (footprint length), and greater cord angles and preferably a larger catenary to cord length ratio.

[0072] Where bottom mounted, deeper water installations of the WEC of the present invention may have a longer foot length (longer footprint), lesser chord angle, tending towards flat, and lesser catenary to cord length ratio.

[0073] When the volume within the cell is pressurised sufficiently to overcome external pressure (e.g. static water pressure from being submerged), the membrane transforms to its maximum inflated state, which creates a convex curved face (in a domed, inverted catenary, 'S' or similar shape), with the chord of the curve inclined at the same 30 deg or so angle to the horizontal as the 'face' (face) of the body of the cell. When the membrane conforms to the cell's face (face) profile or any smooth basin formed into or on the body structure, it takes on that form so that it does not get damaged by wave action in the event of heavy seas whereby the cells can be deflated and the membranes protected by being 'pressed' onto and conforming to the corresponding face or face.

[0074] Each converter, whether having one or more cells, such as each limb (arm/leg) of the converter (and group of cells as a whole), may be pivoted to allow the chord angle to change with respect to the oncoming wave, allowing optimisation of the device according to the strength, (wave height and surge etc.) and direction of the wave.

[0075] Depending on the relative internal and external fluid pressures and motions of the wave at the time, the membrane may form an intermediate profile of an elongated S when viewed in side profile as the wave pressure depresses

firstly the forward lower portion of the membrane. This may be between the upper and lower membrane attachment points of the cell membrane to the cell body.

[0076] Effective width (lateral length) of the membrane preferably matches the
5 effective width (lateral length) of the cell face or wall. This provides for a membrane and fixing arrangement that allows the membrane to conform to the cell face and avoids inducing unnecessary stresses in the membrane.

[0077] In operation, once the cell's volume is fully swept or the membrane is completely deflated, the membrane lays flat on the cell face or wall or basin
10 without any induced stresses, pinches or folds. This enables the converter to survive extreme wave events in the fully deflated state without inducing extreme stresses in the membrane.

[0078] Fluid, such as air, from each cell either:

- 15 i) passes through a set of one way (check) valves for each cell into a (high pressure) manifold combining air from all the cells and onto one of more uni-directional turbines (and subsequently to drive one or more electricity generators). With the air travelling back via a second (low pressure) manifold and second set of check valves to the same or other cell, or
- 20 ii) passes through a duct with a bi-directional turbine in it to a common reservoir (or manifold), refilling the cell from the reservoir once the pressure in the cell drops below the pressure in the reservoir.

[0079] The location of the at least one port of each cell to communicate the air from the cell to the check valves (or bidirectional turbine) enables the cell to maximise sweep of its volume on the deflation stroke and reinflate smoothly,
25 without stiction (static friction whereby the cell membrane can stick to the

opposing face of the cell and not allow fluid (e.g. air) to enter the cell to reinflate it).

[0080] The valving may form part of the face of the body. For example, the face on the body may include valving inserted or mounted therein. A grill or cover
5 may be provided over the valving and preferably providing part of the face.

[0081] This may be achieved by locating the at least one port of each cell integrally with the body of the converter. The at least one port may be cast into the body.

[0082] The at least one port of each cell preferably includes inlet and outlet
10 ports. Alternatively, a single port may communicate with check valves controlling output air flow from the cell and return inflow into the cell via the one port.

[0083] Preferably one or both of the supply port or check valve (high pressure) and return port or check valve (low pressure) is/are positioned adjacent
15 an uppermost limit of the cell face or basin just below the upper membrane restraining edge.

[0084] The converter is preferably configured such that a longitudinal extent of each arm/leg in the direction of the waves is equal to the average wavelength of predominate energy waves in the particular location. This arrangement takes into account that the leg is at an angle to the wave due to the preferred V or chevron
20 formation. This typically results in each leg preferably being 40m to 80m long. However, other lengths are envisaged and will be specified depending upon the prevailing wavelength of the waves for a given location. This configuration allows the air flow from the cells to work in a 'source and sink' mode. As such, one cell is under the peak of a wave (maximum pressure) and pumping air from the cell
25 via the at least one port, and another cell is under the trough (or minimum pressure) of the wave and accepting air back from the reservoir or low pressure manifold via the at least one port.

[0085] The converter is preferably arranged with cells in line horizontally so there is an even average air pressure across the cells.

[0086] Preferably average pressure in each cell can be raised or lowered by a pressure control system. For example, a pneumatic system may be provided to
5 maintain optimum cell pressure as the water depth changes with tidal or other longer term effects and depending on the optimal conditions for the prevailing or current sea state.

[0087] According to one or more preferred embodiments of the present invention, one or more turbines (and one or more electricity generators driven by
10 the respective turbine(s)) may be driven by the air flow from the cell(s) fed from the high pressure manifold and discharging to the low pressure manifold. The turbine(s) and electrical generator(s) may be mounted adjacent or in the apex of the V or chevron so that airflow streams from each arm/leg are combined. Alternatively, separate turbine-generator combinations may be mounted towards
15 or at the end of each leg/arm or anywhere along the leg length or elsewhere.

[0088] Load on the generator(s) (or electrical power output) or performance of the turbine(s) can be varied based on actual or predicted or expected wave height, form and period information so that the pressure differential and flow
20 across the turbine(s) can be controlled or optimised and the resultant turbine speed(s) optimised for maximum electrical energy production.

[0089] The preferred streamlined design of embodiments of the present invention and/or the catenary form or corresponding profile of the membrane or cell face can also be adapted to traditional oscillating water column converters to convert them to membrane converters, eliminating salt laden air from passing
25 over the turbine.

[0090] The converter may also be used for the production of a pressurised third fluid (typically water for storage or sea water – for desalination), by exchanging the electrical generator for at least one pump.

[0091] Whilst the wave energy converter according to various aforementioned
5 embodiments and forms of the present invention is defined within this specification as including a system for wave energy conversion, for the avoidance of doubt, a further aspect of the present invention provides a wave energy conversion system incorporating one or more wave energy converters according to one or more embodiments of the present invention described herein.

10 [0092] The rear face or surface of the membrane within the cell and/or the corresponding face or surface of the body of the cell that contact each other when the cell is deflated may be non-smooth. The surface may have undulations or irregularities, and/or an embossed or raised pattern, to help relieve stiction during refilling of the cell.

15 [0093] A rear of the WEC may include a concave, convex, multi-curved or straight inclined rear face (such as a wedge shape). Particular arrangements can be selected to suit prevailing wave and location conditions (such as depth of water and prevailing wind strength).

[0094] A Concave or straight rear to the WEC or WEC body can help reduce
20 eddy currents at the rear of the WEC, which may help reduce erosion of the seabed/seafloor at the rear. The rear may alternatively or in addition include one or more of the cells with the respective at least one membrane to extract energy from returning waves e.g. returning from land, a beach, cliff or headland or from a manmade structure such as a breakwater or harbour wall. Thus, the WEC may
25 be double sided in terms of cells so that the device extracts wave energy from an oncoming wave and a return wave.

[0095] The membrane may be attached to the body by a spline or bead and clamp arrangement. The spline or bead may be circular or oval in cross section. For example, the material of the membrane may be folded over a spline or may have a hem or sleeve into which a spline is inserted. The splined edge of the
5 membrane is then clamped, such as by putting the splined edge into a channel or groove and applying a fastener to clamp the splined edge into the channel or groove. Alternatively, the membrane may be sealed to the body by a clamp ring around at least part of the external periphery of the membrane. Alternatively, the membrane may be sealed to a support and then mounted to the body. Thus, the
10 membrane and support may be provided as a discrete component.

[0096] The membrane end(s) and/or connections, such as arc, semi-circle, curves and splines can have tangency between and/or be tangential to the main top and bottom connections. This avoids a sharp corner or abutment of top and bottom sides for the membrane connecting to the body.

15 [0097] A further aspect of the present invention provides a method of controlling or optimising fluid pressure within at least one cell of a wave energy convertor (WEC) or within the WEC system, the method including increasing or reducing fluid pressure within each said cell and/or within a low pressure or high pressure conduit(s) and/or manifold of the system.

20

[0098] Preferably the fluid pressure is increased or decreased relative to at least one reference pressure value. The or each reference pressure value may be an average of fluid pressure determined within the or each respective said cell and/or within the low and/or high pressure conduit(s) and/or manifold of the
25 system.

[0099] Average pressure may be determined, at least in part, by averaging various pressures within a cell or across a number of cells at a particular time (simultaneous average pressure) or across one or more cells over time (temporal
30 averaging).

[00100] Preferably the method includes controlling or optimising pressure within the cell(s) to maintain optimum cell pressure as a function of water depth changes with tidal or other longer term effects, and preferably depending on the optimal conditions for the prevailing or current sea state. Thus, as effective water
5 depth increases above the cell(s), pressure within the cell(s) may be increased to balance the increased external pressure from the water, and as water depth decreases, pressure within the cell(s) may be decreased to balance the decreased pressure from the water. In this way, performance and output from the cell(s) and/or system may be optimised for a required output or demand on the
10 system.

[00101] Also, in the event of actual or predicted deterioration in sea conditions, pressure within the cell(s) may be reduced to prevent damage to the membrane. Pressure reduction can, if required, reduce to zero or atmospheric pressure such
15 that the membrane(s) is/are pushed flat by water pressure and do not function until the cell(s) is/are internally pressurised to reinflate the cell(s).

[00102] Embodiments of the present invention will hereinafter be described with reference to the accompanying drawings, of which:

20 BRIEF DESCRIPTION OF THE DRAWINGS

[00103] Figures 1a to 1k show, in sequential steps, wave action on the membrane for a fully swept cell volume over a complete wave sequence for a WEC according to an embodiment of the present invention.

[00104] Figures 1m to 1w show, in sequential steps, wave action on the
25 membrane for a fully swept cell volume over a complete wave sequence for a WEC, and showing representations of wave flow lines, according to an embodiment of the present invention.

[00105] Figures 1l and 1x show a WEC according to an embodiment of the present invention with the membrane completely deflated.

[00106] Figures 2a to 2k show in sequential steps wave action on the membrane for a half swept cell volume over a complete wave sequence for a
5 WEC according to an embodiment of the present invention.

[00107] Figure 2l shows a membrane of a WEC according to an embodiment of the present invention, the membrane completely deflated.

[00108] Figures 3 and 4 show alternative mounting arrangements of wave energy converters (WECs) according to embodiments of the present invention.

10 [00109] Figure 5 shows a cross section through a WEC with a single radius curvature cell face according to an embodiment of the present invention.

[00110] Figures 6a to 6d show various arrangements for a dual radius curvature cell face according to alternative embodiments of the present invention.

[00111] Figures 7a to 7c show various arrangements for a triple radius
15 curvature cell face according to alternative embodiments of the present invention.

[00112] Figures 8a to 8d show alternative arrangements of WEC with different chord angle alignments in respect of oncoming waves, according to alternative embodiments of the present invention.

[00113] Figures 9a to 9d show alternative mooring/anchoring arrangements
20 according to embodiments of the present invention.

[00114] Figures 10a to 10c show sections through alternative forms of WEC according to embodiments of the present invention.

[00115] Figures 11a to 11d show sections through alternative forms of WEC and including at least one valving or porting option according to embodiments of the present invention.

[00116] Figures 12a and 12b show an alternative valving or porting option for a
5 WEC according to an embodiment of the present invention and a close coupled turbine adjacent the cell according to an embodiment of the present invention.

[00117] Figures 13a and 13b show a multi cell WEC and membrane positions according to an embodiment of the present invention.

[00118] Figures 14a to 14c show a single cell longitudinal bank form of WEC
10 according to an embodiment of the present invention.

[00119] Figures 15a to 15c show a multi cell longitudinal bank form of WEC with integrated flexible divider walls according to an embodiment of the present invention.

[00120] Figures 16a to 16c show a multi cell longitudinal bank form of WEC
15 with diaphragm cell dividers according to an embodiment of the present invention.

[00121] Figures 17a to 17c show a multi cell longitudinal bank form of WEC with fixed divider walls between adjacent discrete cells according to an embodiment of the present invention and consistent with figures 13a and 13b.

[00122] Figure 18 shows a section through a WEC showing a valving
20 arrangement according to an embodiment of the present invention.

[00123] Figure 19 shows a V or chevron configuration of two linear arrays or banks of multi cells forming a combined WEC arrangement according to an embodiment of the present invention.

[00124] Figure 20 is a perspective of V or chevron configuration of two linear arrays or banks of multi cells forming a combined WEC arrangement according to an embodiment of the present invention.

[00125] Figures 21 to 23 show cell membrane displacement sequences with respect to an impinging wave according to embodiments of the present invention.

[00126] Figures 24 to 26 show various arrangements of linear array or bank configurations of WEC for near shore application according to embodiments of the present invention.

[00127] Figures 27 to 29 show various linear array or bank forms corresponding to the respective arrangements shown in figures 24 to 26.

[00128] Figures 30 and 31 show deep water applications of the WEC according to embodiments of the present invention, with Figures 30s and 31s showing respective cross sections.

[00129] Figures 30a, 30b, 30c and 30d show alternative deep water applications of WECs according to embodiments of the present invention. Figure 30a shows a wind turbine mounted on a floating WEC. Figure 30b shows a seabed/seafloor mounted submerged version with wind turbine tower projecting upwards therefrom. Figures 30c and 30d show an alternative embodiment of a WEC and wind turbine combination according to a further embodiment of the present invention.

[00130] Figures 32 to 34 show breakwater and oscillating water column (OWC) applications of WECs according to embodiments of the present invention.

[00131] Figures 35 and 36 show an alternative embodiment of the breakwater WEC of Figures 32 and 33.

[00132] Figure 37 shows a coffer dam type breakwater application incorporating a WEC according to an embodiment of the present invention.

[00133] Figures 38 to 42 show alternative forms of a WEC according to embodiments of the present invention.

- 5 [00134] Figures 43 to 46 show various arrangements of process, piping and instrumentation of systems for controlling flow of a secondary fluid from one or more cells of WECs through one or more turbines to convert wave energy to harnessed energy according to embodiments of the present invention.

DESCRIPTION OF PREFERRED EMBODIMENTS

- 10 [00135] Figures 1a to 1k show a wave energy converter (WEC) 10 on a seabed or sea floor 12, resting on the seabed under its own weight. The sequential steps show the action of a wave 14 on a flexible membrane 16 of the WEC over a complete wave sequence for a WEC according to an embodiment of the present invention. The wave has a peak 14a and trough 14b. The WEC has a body 18
15 with an integral face 20. It will be appreciated that the face can be separately applied to the body, such as a discrete face member. The face member and membrane may be pre attached to each before mounting to the body. Alternatively, the membrane may be connected to the body by other attachment means. The membrane and face are sealed watertight with respect to the
20 exterior wave such that they define a variable volume cell 22 therebetween. The volume of that cell is increased by a pressurised supply of a fluid within the WEC sufficient to resist pressure of the wave at a trough 14b in the wave form so that the membrane inflates and is under tension. As the wave peak 14a approaches and passes over the WEC (Figs 1a to 1f), surge and heave pressure within the
25 wave increases and the membrane is compressed towards the face, normally from a lower forward portion, such that the cell volume is compressed and fluid within the cell is squeezed upwards gradually progressing rearward and upward with respect to the cell's rearward and upward inclination.

[00136] Figures 1m to 1w show the same operation of the WEC 10 as shown in Figures 1a to 1k, though including wave flow lines. These wave flow lines represent the general flow and movement of the wave over the WEC 10. It will be appreciated that the membrane 16 begins deforming before the peak 14a of the wave 14 is directly above the WEC 10. This is due to the pressure front leading the wave as the wave peak 14a approaches the WEC.

[00137] It will be appreciated that the cell in this embodiment is inclined or angled rearward with a lower portion forward of its upper portion such that the lower portion encounters the force of the wave first and the wave pressure progresses rearward thereby forcing the cell volume to constrict from the lower portion towards to upper portion.

[00138] It will also be appreciated that due to the fluid nature of the energy in the wave and the flexible nature of the membrane, the membrane may not be compressed evenly and orderly, yet the volume within will still be generally compressed from the lower portion to the upper portion. The face 20 is generally the same length and width as the membrane and a length, curvature or shape generally matching but opposite to the length, curvature or shape of the membrane when the membrane is at a fully inflated state (see fig 1a). When the membrane is fully compressed to the face, as in fig 1f, the membrane lies flat against the face. As the wave continues to pass over the WEC (see figs 1g to 1k) and pressure decreases on the membrane (i.e. the peak of the wave 14a has passed), return pressure re-inflates the membrane from the upper rearward portion progressing down to the lower forward portion ready for the next wave.

[00139] Figures 1l and 1x show the membrane fully retracted or pressed back onto the face. This allows the membrane to be kept safe in the event of rough sea conditions, tidal surges or large waves that might otherwise over pressure the cells or cause damage to the membrane, or even potentially shift the WEC from its anchorage. This feature allows the WEC to be de-energised from the wave resource in the event of a WEC component failure to prevent further damage to

the faulted component or associated components. This feature allows the WEC to be de-energised to enables maintenance activities to be undertaken safely.

[00140] Figures 2a to 2k show in sequential steps wave action on the membrane for a half swept cell volume (c/w figs 1a to 1k and 1m to 1w) over a complete wave sequence for a WEC according to an embodiment of the present invention.

[00141] Figures 3 and 4 show a WEC 10 and some alternative mounting and configuration arrangements therefore according to embodiments of the present invention. The WEC 10 has a body 18. A cell volume 22 is formed by a membrane 16 and a cell face 20. The WEC forms a generally wedge shaped or streamlined aerofoil shape. In cross section, the WEC is lower in height at the front 24 than at the rear 26 with respect to impinging waves in direction W.

[00142] In Figure 3, the WEC is anchored in sand or concrete 28 to the seabed 12. The WEC has supply (outlet) 30 and return 32 conduits each connected by respective supply (outlet) 34 and return (inlet) 36 ports communicating with the cell volume 22.

[00143] Valving can be provided to control flow into the supply conduit and out of the return conduit with respect to the cell. A single port may be provided with fluid flow from the cell to the supply conduit and return from the return conduit into the cell. A pair of one way valves may be provided. Alternatively a bi-directional turbine may be provided to harness the fluid flow in both directions. In this configuration, a rear face 38 of the WEC and an upper rear corbel 40 help to control return wave RW flow back over the WEC. It will be appreciated that the curve of the membrane 16 when fully inflated and the curve of the face 20 can share a common length 42 such that the membrane lies comfortably over the face when fully deflated.

[00144] Figure 4 shows the WEC 10 mounted on piers 42 raising the WEC from the seabed bathymetry conditions so that the device is levelled and closer to the mean still water level. The piers help the WEC to sit at the correct depth in the water to meet with required specification and performance criteria from the
5 WEC in relation to the depth of water and general wave conditions.

[00145] Figure 5 shows a cross section through a WEC 10 of the present invention with a single radius curvature cell face 20. A chord 42 is common to the membrane 16 and face 20 such that the membrane can lie flat against the face when fully deflated or pressed back onto the face. Thus, each of the sections 16a,
10 16b, 20a,20b are of the same general length.

[00146] Figures 6a to 6d show various arrangements for a dual radius curvature cell face 20 according to alternative embodiments of the present invention. The cell face has a first curved portion 44 and a second curved portion 46. The membrane has a section length equivalent to the length of the combined
15 first and second curved portions.

[00147] Figures 7a to 7c show various arrangements for a triple radius curvature 44, 46, 48 cell face 20 according to alternative embodiments of the present invention.

[00148] Figures 8a to 8d show alternative arrangements of WEC with different
20 chord angle 42 alignments at 90°, 45°, 30° and 0° in respect of oncoming waves W, according to alternative embodiments of the present invention. It will be appreciated that other angle alignments can be used, which can be selected based on the style of WEC deployed and prevailing location (direction, water depth etc) and wave conditions.

25 [00149] Figures 9a to 9d show alternative mooring/anchoring arrangements according to embodiments of the WEC 10 of the present invention.

[00150] Figure 9a shows seabed anchored 50 version, for example, using concrete, sand, geotextile bags or rocks, or combinations thereof. Figure 9b shows a footing or pile 52 mounted version.

[00151] Figure 9c shows a footing or pile mounted version whereby the WEC is pivotably attached 54 to the pile/footing towards the front of the WEC. This allows the WEC to be hinged forward to adapt to changes in prevailing wave conditions by altering the angle β to tilt the WEC forward. Variable ballast may be employed to control lift or lowering of the WEC about the pivot 54. The ballast can be water, such as seawater pumped into or evacuated out of a chamber or conduit through the WEC.

[00152] An alternative version shown in Figure 9d has a tethered mooring using a tether 58 attached to a tether point 60 at one end and a mooring 62 at the other. In such an arrangement, the WEC can be ballasted so as to be buoyant within the water, preferably neutrally buoyant at a preferred depth. This can be achieved by controlling the variable ballast 56.

[00153] Figures 10a to 10c show sections through alternative forms of WEC according to embodiments of the present invention. Figure 10a shows a convex curved rear version, figure 10b shows a sloping rear version and 10c a concave or corbelled version, figure 10d a convex version. The different versions of rear are provided for different wave and location requirements. The various rear options act to modify return wave flow and thereby can be used to maximise WEC efficiency for a given application and location.

[00154] Figures 11a to 11d show sections through alternative forms of WEC and including at least one valving option according to embodiments of the present invention.

[00155] Figure 11a shows dual or twin ports or ducts. An outlet or supply conduit 64 and an inlet or return conduit 66 are provided. The cell volume 22

communicates with the conduits via one or more ports to/from the cell volume and valving 68. The valving shown in figure 11b has alternate one way valves 70,72. The uppermost valves 70 supply fluid from the cell volume to the supply conduit. The lower valves 72 return fluid to the cell volume from the return conduit.

- 5 Sections A-A and B-B are shown respectively in Figures 11c and 11d. These show the outlet port(s) 74 from the cell and the inlet port(s) 76 to the cell volume.

[00156] Figures 12a and 12b show an alternative valving option for a WEC according to an embodiment of the present invention. A bi-directional turbine 80 is provided in a single port 82.

- 10 [00157] Figure 12b shows a view into the port and the turbine from the cell volume.

- [00158] Figures 13a and 13b show a multi cell WEC and membrane positions according to an embodiment of the present invention. A bank or array of WEC cells is provided as a single unit. A single body 18 houses multiple cells. It will be appreciated that each cell may be formed or cast in the single body, or discrete cell body portions may be formed and then connected together to form the single body. The supply and return conduits 64, 66 may be integral to the body portion(s) or may run externally of the WEC in individual conduits in the form of pipes.
- 15

- 20 [00159] Figure 13b shows part of the section A-A of fig 13a, with the left-hand membrane partially compressed, the centre membrane fully inflated and the right-hand membrane completely deflated.

- [00160] Figures 14a to 14c show a single cell longitudinal bank form of WEC according to an embodiment of the present invention. The single cell clearly has no divider walls.
- 25

[00161] Figures 15a to 15c show a multi cell longitudinal bank form of WEC with integrated flexible divider walls 84 according to an embodiment of the present invention. The divider walls between cells are shared between adjacent cells i.e. one cell wall between each adjacent pair of cells.

5 [00162] Figures 16a to 16c show a multi cell longitudinal bank form of WEC with diaphragm cell dividers according to an embodiment of the present invention. Thus, each cell is a discrete thing having its own walls and membrane. Figures 17a to 17c show a multi cell longitudinal bank form of WEC with fixed, preferably rigid, divider walls between adjacent discrete cells, each with its own membrane,
10 according to an embodiment of the present invention.

[00163] Figure 18 shows a section through a WEC showing a porting and valving arrangement according to an embodiment of the present invention. The WEC 10 includes a body portion 18 with integral conduits 64, 66 for respective supply and return flow of fluid. Flow from the cell volume 22 is through an outlet
15 port 74 through the valving 68 into the supply conduit 64. return flow is from the return conduit 66 via the valving 68 into the cell volume 22. The valving includes separate outlet valves and return one way valves. The valving can be provided as a cartridge component that is replaceable. Preferably the valving is accessible by removing an access port cover at a rear of the WEC 10 and preferably in-line
20 with the axis of the valving 68. The valving 68 is released and then withdrawn rearward and upward. The replacement valving is then inserted in a downward and forward motion, then locked in location and the access port cover reinstated. The face and/or the membrane may seal to the body in a watertight or near watertight manner sufficient to allow efficient operation of the WEC with minimal
25 leakage into or out of the conduits.

[00164] The wedge shaped profile of the WEC 10 encourages the wave to ramp up on approach to the WEC and then ride over the WEC with minimal disturbance whilst maximising wave surge to wave heave conversion and thereby maximising wave energy conversion as the membrane compresses.

[00165] Figure 19 shows a V or chevron configuration of two linear arrays or banks of multi cells forming a combined WEC arrangement according to an embodiment of the present invention. Angle γ between the two limbs (arms/legs) 10a,10b of the WEC can be set at a desired value such that the arms/legs are
5 angled with respect to each other to suit prevailing location and wave needs. The angle may be variable, such as by powered or manual adjustment between the two limbs. Power generation and/or pumping equipment and/or angle adjustment equipment may be provided at the juncture 90 between the two limbs.

[00166] Figure 20 is a perspective of V or chevron configuration of two linear
10 arrays or banks of multi cells forming a combined WEC arrangement according to an embodiment of the present invention.

[00167] Figures 21 to 22 show cell membrane displacement sequences with respect to an impinging wave according to embodiments of the present invention. The upper graph A for each figure represents wave height and pressure. The
15 lower graph B for each figure represents cell vertical displacement of the membrane of each cell. Each figure also shows a representation of the pattern of actual cell membrane displacement for each sequence across the WEC limb 10a.

[00168] Figures 24 to 26 show various arrangements of linear array or bank configurations of WEC for near shore application according to embodiments of
20 the present invention.

[00169] Figure 24 shows a near shore ocean facing apex with the limbs pointing towards the shore. Figure 25 shows a near shore, shore facing apex with the limbs of the WEC pointing towards open water.

[00170] Figure 26 shows a single limb or spine version of the WEC near shore.

25 [00171] Figures 27 to 29 show various linear and non linear array or bank forms corresponding to the respective arrangements shown in figures 24 to 26.

[00172] Figures 30 and 31 show deep water applications of the WEC 10 according to embodiments of the present invention. In figure 30, the annular array 90 of cells 22 of the WEC 10 allows for efficient conversion of wave energy from any direction. Thus, wave energy conversion over a period for different
5 wave directions over a period of time can be averaged. Section A-A (Figure 30s - 's' for section) of figure 30 shows a cross section of a general arrangement of the cells.

[00173] Figure 31 shows an alternative embodiment of the deep water version of WEC with some cells internal to the opening through the annulus and other
10 cells external to the opening. Section B-B (Figure 31s - 's' for section) shows a cross section of a general arrangement of the cells.

[00174] The WEC embodiments in figures 30 and 31 extract energy from waves first impinging on one side of the annulus to also extract energy from the wave as it passes across the annulus and impinges on the inside face of the
15 annulus. Such deep water applications may be tethered floating applications either on the surface of the waves or neutrally buoyant below the surface of the waves, or rigidly mounted on a pylon, offshore wind turbine tower, oil or gas rig or other similar ocean or deep water device.

[00175] Figures 30a and 30b show alternative deep water applications of
20 WECs according to embodiments of the present invention. Figure 30a shows a wind turbine 114 integrated with a floating WEC similar to that shown in Figure 30, though with a central (cruciform) support 110 for the mast 112 of a wind turbine 114. Other forms of support for the wind turbine, or other device, can be provided, such as a central single spar, a solid or mesh platform, or a framework.
25 The WEC is tethered 116 to the seabed, allowing the WEC to float but not drift away. Electricity generated by the wind turbine may be used to power electrical equipment, such as pumps and control systems and safety systems relating to the WEC.

- [00176] Figure 30b shows an alternative version providing a seabed/seafloor mounted submerged WEC 120 with a wind turbine mast 122 projecting upwards therefrom. The WEC is mounted on supports 124 into the seabed/seafloor 126. The WEC may move up and down with respect to the seabed/seafloor to cater for changes in water depth and sea conditions, which allows the WEC to be optimised for prevailing sea/weather conditions, or to be lowered to the seabed/seafloor in the event of rough sea/weather conditions. A cruciform support 110 supports the mast, which itself can be braced by lateral supports 126.
- [00177] Figures 30c and 30d show a deepwater application of a WEC according to an embodiment of the present invention. The WEC 10 is mounted to the mast 112a of the wind turbine 114a. In particular, figure 30d shows a vertical section E-E through the WEC 10 and mast 112a of the wind turbine 114a. The mast is embedded in the seabed/seafloor 12. The WEC is rotatable about the mast. Control of rotation can be effected by a winch 190 connected to each end of the WEC by one or more tethers 192,194. A single continuous tether (continuous tether 192+194) may pass around the winch pulley 190, or separate tethers may be provided 192, 194, each controlled to effectively lengthen or shorten to allow the WEC to rotate. This allows the WEC to be swung to face the prevailing oncoming waves to maximise wave energy conversion, or to be angled to control how much effect the waves have on the WEC i.e. to limit energy conversion, which can be especially useful in strong wave conditions when facing waves full on may be less than fully efficient due to the frequency, peak to trough height or forces from the waves. To allow for changes in water depth and/or wave height with respect to the mast, the WEC may travel up and down with respect to the mast. One or more guides, such as tracks, guide wheels, rollers etc. 198 may be provided on the mast, on the WEC or both. These allow the WEC to travel freely up and down or to be controlled to maintain a required position or depth.
- [00178] Figures 32 to 34 show breakwater applications of WECs according to embodiments of the present invention. The WEC 10 is provided as a linear array

or bank of cells positioned close to shore and forming an edge of a jetty 96 extending out into the water 14. The jetty may be a solid or near solid breakwater.

[00179] Figure 33 shows cross section C-C through a breakwater and WEC 10.

5 [00180] A WEC 10 adapted for harsh conditions may be provided, as shown in fig 34. The WEC includes one or multiple cells 22 with respective one or more membranes 16. A single port 98 leads to a bi-directional turbine 100 and into an upper single supply and return conduit or chamber 102. A lower chamber 104 can be filled with ballast, such as water or concrete or rubble for additional weight
10 to prevent the WEC moving in rough sea or tidal surge conditions. It will be appreciated that separate supply and return conduits may be provided, with associated one way valving.

[00181] As shown by way of example in figures 38 to 40, the wave energy converter 10 may have alternative forms of rear wall arranged to direct return flow
15 142 of water. For example, figure 38 shows a double curved or 'S' shaped rear 130, whereas figure 39 shows a concave rear 132, and figure 40 a straight (or wedge or 'triangular' when referring to the general body shape of the WEC 10) shaped rear 134. These alternative forms of rear can be employed when a convex curved rear might result in eddy currents immediately at the base of the
20 rear adjacent the seabed/seafloor. Such eddy currents 140 from the return flow 142 might potentially cause erosion of the seafloor 14 adjacent the rear of the WEC, as shown in figure 41.

[00182] Figure 42 gives an example of a WEC with a convex rear 136 and that is raised off the seafloor a distance 'd' to allow some of the return flow to pass
25 under the WEC and thereby avoid such eroding eddy currents.

[00183] Figures 43 to 46 show alternative arrangements of process and instrumentation diagrams (P&ID) of the circuits for directing the converted wave

energy via a secondary fluid through one or more turbines. In particular, figure 43 shows a double diaphragm bank of cells 144,146 with common manifolds 148, 150 and a single (shared) turbine 152. This arrangement can be used in a V bank configuration with closed loop dual pneumatic circuit (rectified flow) and a
5 single axial turbine coupled to an electric generator.

[00184] Figure 44 shows a double diaphragm bank of cells 154,156 but with cross flow manifolds 158, 160, each connected to a respective one of a pair of turbines 162, 164. This also relates to a V configuration of banks of cells, with closed loop dual pneumatic circuit (rectified flow) and dual axial turbines coupled
10 to electric generators.

[00185] Figure 45 provides an arrangement of WEC with a single diaphragm bank of cells 166, 168 with cross flow manifold 170, 172 and double turbines 174, 176. This single bank arrangement has closed loop dual pneumatic circuit cross flow (rectified flow) and dual axial turbines coupled to electric generators.

15 [00186] Figure 46 shows a single diaphragm bank of cells 178 with single manifold 180 and bi-directional turbines 182. This provides open loop ducting (applicable to all configurations). A rectifying turbine and generator are mounted in the port between diaphragm cell and common transfer manifold. Multiple turbines per diaphragm cell is also possible.

20 [00187] It will be appreciated that performance of the wave energy convertor cell(s) and or system can be controlled or optimised to suit prevailing or predicted sea conditions or to match a required level of performance or demand.

[00188] Fluid pressure within one or more of the cells, or within the system
25 including the cell(s), can be increased or decreased as required. For example, fluid pressure within a low pressure or high pressure conduit(s) and/or manifold of the system can be varied.

[00189] Preferably the fluid pressure is increased or decreased relative to at least one reference pressure value. Fluid pressure can be determined by readings from one or more pressure sensors within the cell(s) and/or conduits and/or manifold of the system. Such pressure sensors can provide pressure related signals to a processor to determine required pressure values, and therefrom be used as a factor to control or optimise the fluid pressure.

[00190] The or each reference pressure value can be an average of fluid pressure determined within the or each respective said cell and/or within the low and/or high pressure conduit(s) and/or manifold of the system.

[00191] Average pressure may be determined, at least in part, by averaging various pressures within a cell or across a number of cells at a particular time (simultaneous average pressure) or across one or more cells over time (temporal averaging).

[00192] Preferably the method includes controlling or optimising pressure within the cell(s) to maintain optimum cell pressure as a function of water depth changes with tidal or other longer term effects, and preferably depending on the optimal conditions for the prevailing or current sea state. Thus, as effective water depth increases above the cell(s), pressure within the cell(s) may be increased to balance the increased external pressure from the water, and as water depth decreases, pressure within the cell(s) may be decreased to balance the decreased pressure from the water. In this way, performance and output from the cell(s) and/or system may be optimised for a required output or demand on the system.

[00193] Also, in the event of actual or predicted deterioration in sea conditions, pressure within the cell(s) may be reduced to prevent damage to the membrane. Pressure can, if required, be reduced to zero or atmospheric pressure such that the membrane(s) is/are pushed flat by water pressure and do not function until the cell(s) is/are internally pressurised to reinflate the cell(s).

CLAIMS:

1. A wave energy converter (WEC), including a body portion and at least one flexible membrane bounding at least part of a volume of a fluid, a substantial portion of the at least one membrane inclined from vertical providing a flow
5 smoothed way for wave energy to travel over the WEC whilst deforming the at least one membrane towards the body to compress the fluid, the inclination of the at least one membrane assisting conversion of potential and kinetic energy of the wave to pressure within the fluid.
2. A wave energy converter (WEC), including a body portion and at least one
10 flexible membrane forming at least part of at least one cell volume for pressurised fluid, the at least one membrane inclined from a lower portion to an upper portion thereof to allow a wave impinging on the WEC to flow over the at least one membrane and forces from surge and heave of the wave to deform the at least one membrane towards the body to compress the fluid in the at least one volume.
- 15 3. A WEC according to claim 1 or 2, including at least one port, wherein, when wave pressure higher than pressure of fluid within a cell volume impinging against the membrane causes deformation of the membrane, the pressurised fluid is forced out of the cell via the at least one port.
4. A WEC according to claim 3, wherein the at least one port is at or adjacent an
20 upper rearward portion of the respective cell.
5. A WEC according to any one of the preceding claims, wherein the body includes at least one respective face that opposes a said respective at least one membrane and towards which the membrane is deformed by the wave force.
6. A WEC according to claim 1 or 2 where the lower portion is forward and the
25 upper portion is rearward.

7. A WEC according to claim 1 or 2 where the body portion and the at least one membrane incline upward and rearward from the lower portion to the upper portion.
8. A WEC according to any one of the preceding claims, wherein the pressurised fluid within the cell is air or other gaseous fluid.
9. A WEC according to any one of the preceding claims, including multiple said cells.
10. A WEC according to claim 9, wherein the cells are rigidly attached to one another to form a multi cell WEC.
- 10 11. A WEC according to claim 5, wherein one or more of the at least one face is formed by casting or moulding as part of the body or is formed on a rigid or semi rigid face member to attach to the body to form a desired face profile.
12. A WEC according to claim 5 or 11, wherein the membrane is attachable to the face member as part of a unit mountable to the converter.
- 15 13. A WEC according to claim 5 or 11, wherein the at least one face is cast into the body.
14. A WEC according to any one of the preceding claims, wherein the at least one membrane is removably attachable to the body.
15. A WEC according to any one of the preceding claims, wherein the or each membrane takes on a convex shape once inflated by sufficient interior pressure within the respective cell overcoming exterior pressure.
- 20 16. A WEC according to claim 15, wherein the convex shape inclines at an angle to horizontal and vertical.

17. A WEC according to any one of the preceding claims, wherein a forward most portion of the respective cell is below a rearward most portion of that cell such that the cell inclines upwards from the front to the rear thereof.
18. A WEC according to claim 10 or 11, wherein the at least one cell is inclined
5 between 0° and 90° from horizontal.
19. A WEC according to claim 18, wherein the at least one cell is inclined between 20° and 60° from horizontal.
20. A WECD according to any one of the preceding claims, the converter including anchorage or attachment to the seabed.
- 10 21. A WEC according to any one of the preceding claims, provided as a near shore submerged, pneumatic, attenuation type WEC or as an offshore submersed deep water WEC or as a breakwater WEC.
22. A WEC according to any one of the preceding claims, further including a rear
15 of the converter including an exterior fluid flow control, straight, curved or rounded portion.
23. A WEC according to any one of the preceding claims, wherein multiple said cells are arranged as one or more linear arrays.
24. A WEC according to claim 23, wherein two linear arrays are connected to form a V or chevron arrangement.
- 20 25. A WEC according to claim 24, wherein an apex of the V or chevron is orientated, in use, towards or to face the direction of the oncoming waves or the open sea/ocean and arms or legs of the V or chevron extend from the apex towards the shore such that the waves approach the apex first and the V or chevron and each arm/leg obliquely.

26. A WEC according to claim 24, wherein an apex of the V or chevron arrangement points towards the shore and away from the waves, such that the arms or legs of the V project away from the apex towards open water.
27. A WEC according to any one of claims 25 or 26, wherein an included angle of
5 the V or chevron is substantially or approximately between 45° and 175°.
28. A WEC according to claim 27, wherein the included angle is between 60° and 120°.
29. . A WEC according to claim 25, configured in an open curve or arc arranged to be orientated either with an open side towards shore or with the open side
10 towards open water.
30. A WEC according to any one of the preceding claims, configured as a submersible WEC.
31. A WEC according to any one of the preceding claims, including a circular or annular configuration of said cells to accept omnidirectional wave spectra.
- 15 32. A WEC according to any one of the preceding claims, wherein, during initial compression of the membrane in use, an intermediate profile of an elongated S when viewed in side profile is formed in the membrane as the wave pressure depresses firstly the forward lower portion of the membrane which squeezes fluid within the cell volume towards the at least one port of the cell higher up.
- 20 33. A WEC according to any one of the preceding claims, wherein effective width of the membrane matches the effective width of the cell face.
34. A WEC according to any one of the preceding claims, wherein at least one port associated with each cell is located adjacent an upper portion of the cell to communicate the fluid from the cell to at least one check valve(s) or bidirectional

turbine thereby enabling the cell to maximise sweep of its volume by compression of the membrane by the wave pressure on the deflation stroke.

35. A WEC according to claim 23, 24 or 25, wherein a longitudinal extent of each linear array is equal to an average wavelength of predominate energy waves in a particular location

36. A WEC according to claim 28, wherein the or each linear array is between 40m and to 80m long.

37. A WEC according to any one of claims 23, 24, 25, 35 or 36, wherein the array is arranged such that when one cell is under the peak pressure of a wave and pumping fluid out from the cell via the at least one port, another cell is under minimum pressure of a wave and accepting return fluid from a reservoir or low pressure manifold via that cell's at least one port.

38. A WEC according to any one of the preceding claims, further including a control system arranged to raise or lower average pressure in each said cell and/or within a low pressure or high pressure manifold of the system.

39. A WEC according to claim 38, wherein the control system includes a pneumatic system to maintain optimum cell pressure as the water depth changes with tidal or other longer term effects and depending on the optimal conditions for the prevailing or current sea state.

40. A WEC according to any one of the preceding claims, further including one or more turbines driven by the pressure flow from the cell(s), the one or more turbines driving one or more electrical generators.

41. A WEC according to claim 40, wherein when multiple said cells are arranged in a V or chevron, the turbine(s) and electrical generator(s) are mounted adjacent

or in an apex of the V or chevron so that airflow streams from each arm/leg are combined.

42. A WEC according to claim 40, wherein when multiple said cells are arranged in a V or chevron, the turbine(s) and electrical generator(s) are mounted towards
5 or at the end of each leg/arm thereof or anywhere along the leg/arm length.

43. A WEC according to any one of the preceding claims, wherein converter includes at least one pump powered from one or more turbines driven by the flow of pressurised fluid from the cell(s).

44. A WEC according to any one of the preceding claims, provided as a kit of
10 parts.

45. A WEC according to any one of the preceding claims, wherein the body is formed of precast concrete.

46. A WEC according to claim 43 or 44 or 45, wherein at least a portion of the respective cell is formed integrally with the body.

15 47. A WEC according to claim 5 or 11, wherein one or more of the faces includes an opening to receive at least one replaceable valve or bi-directional turbine.

48. A WEC according to any one of the preceding claims, a multi-curved, convex, concave or straight rear or rear face.

20 49. A WEC according to any one of the preceding claims, including at least one said cell on opposing sides, at least one said cell on a first side to extract energy from a wave, and at least one other said cell to extract energy from a returning said wave.

50. A WEC according to any one of the preceding claims, wherein the membrane is attached to or adjacent upper and lower portions of the converter body.

51. A WEC according to any one of the preceding claims, wherein the membrane at one or more ends of the WEC respectively forms a curve, semicircle, arc or spline.

52. A WEC according to claim 51, wherein the membrane at the respective end utilises either elastomeric properties or is geometrically shaped such that the elastomeric strain / stress is reduced.

53. A wave energy conversion system including a WEC according to any one of claims 1 to 52, and electrical power generation equipment mounted thereon or adjacent thereto.

54. A method of controlling or optimising fluid pressure within a wave energy convertor (WEC) system, the method including increasing or reducing fluid pressure within at least one cell and/or within a low pressure or high pressure conduit(s) and/or within at least one manifold of the system.

55. The method according to claim 54, including increasing or decreasing the fluid pressure relative to at least one reference pressure value.

56. The method according to claim 55, whereby the or each reference pressure value is an average of fluid pressure determined within the or each respective said cell and/or within the low and/or high pressure conduit(s) and/or manifold of the system.

57. The method according to claim 56, whereby the average pressure is determined, at least in part, by averaging various pressures within a cell or across a number of cells of the WEC system at a particular time or across one or more cells over time.

58. The method according to claim 54, including controlling or optimising fluid pressure within the cell(s) to maintain optimum cell fluid pressure as a function of water depth changes with tidal or other effects.

59. The method according to claim 58, whereby fluid pressure within the cell(s) is
5 increased with an increase in water depth to balance the increased external pressure from the water, and as water depth decreases, fluid pressure within the cell(s) is decreased to balance the decreased pressure from the water.

60. The method according to claim 54, in the event of actual or predicted
10 deterioration in sea conditions, reducing fluid pressure within the cell(s) to prevent damage to the membrane.

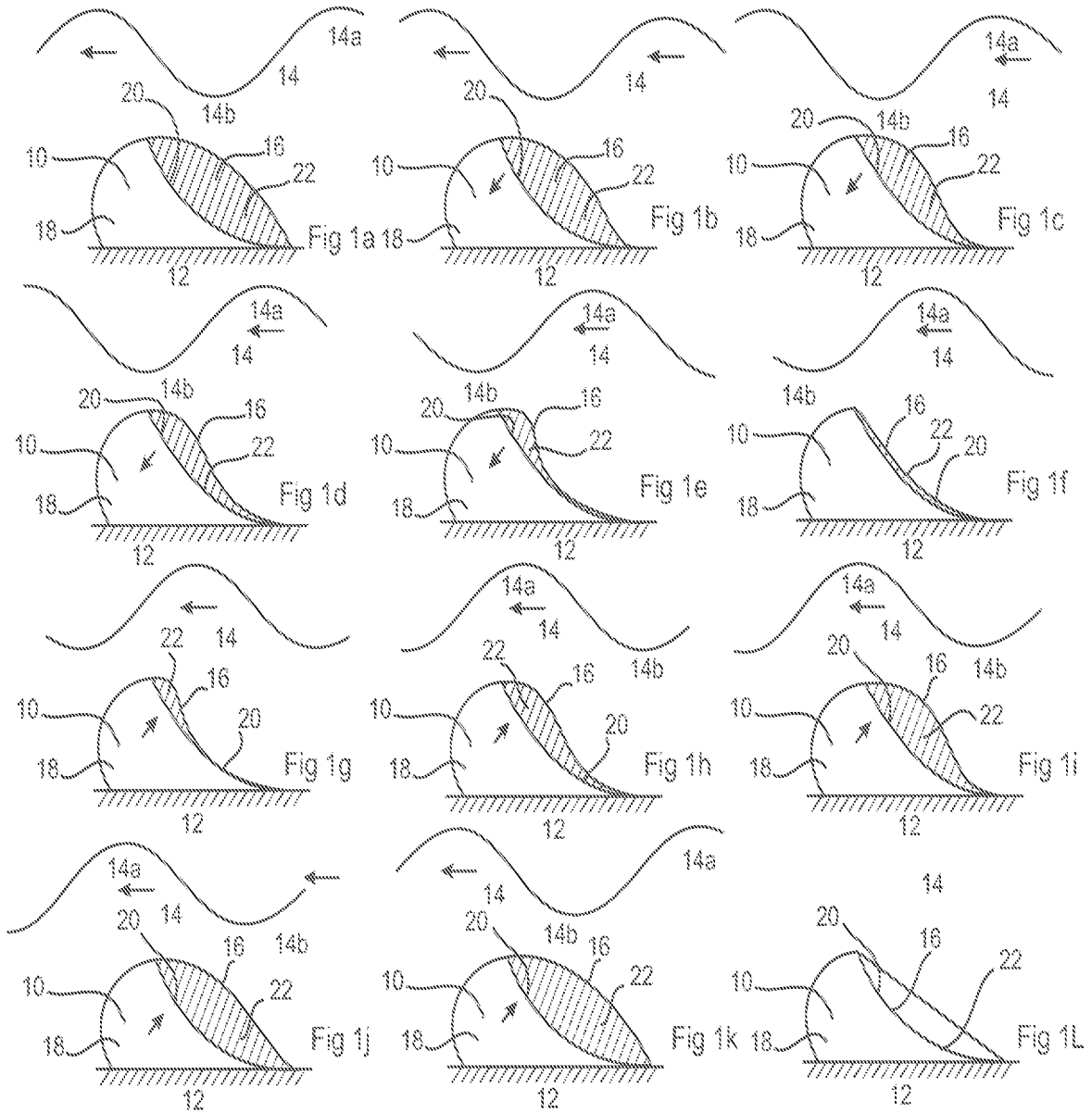

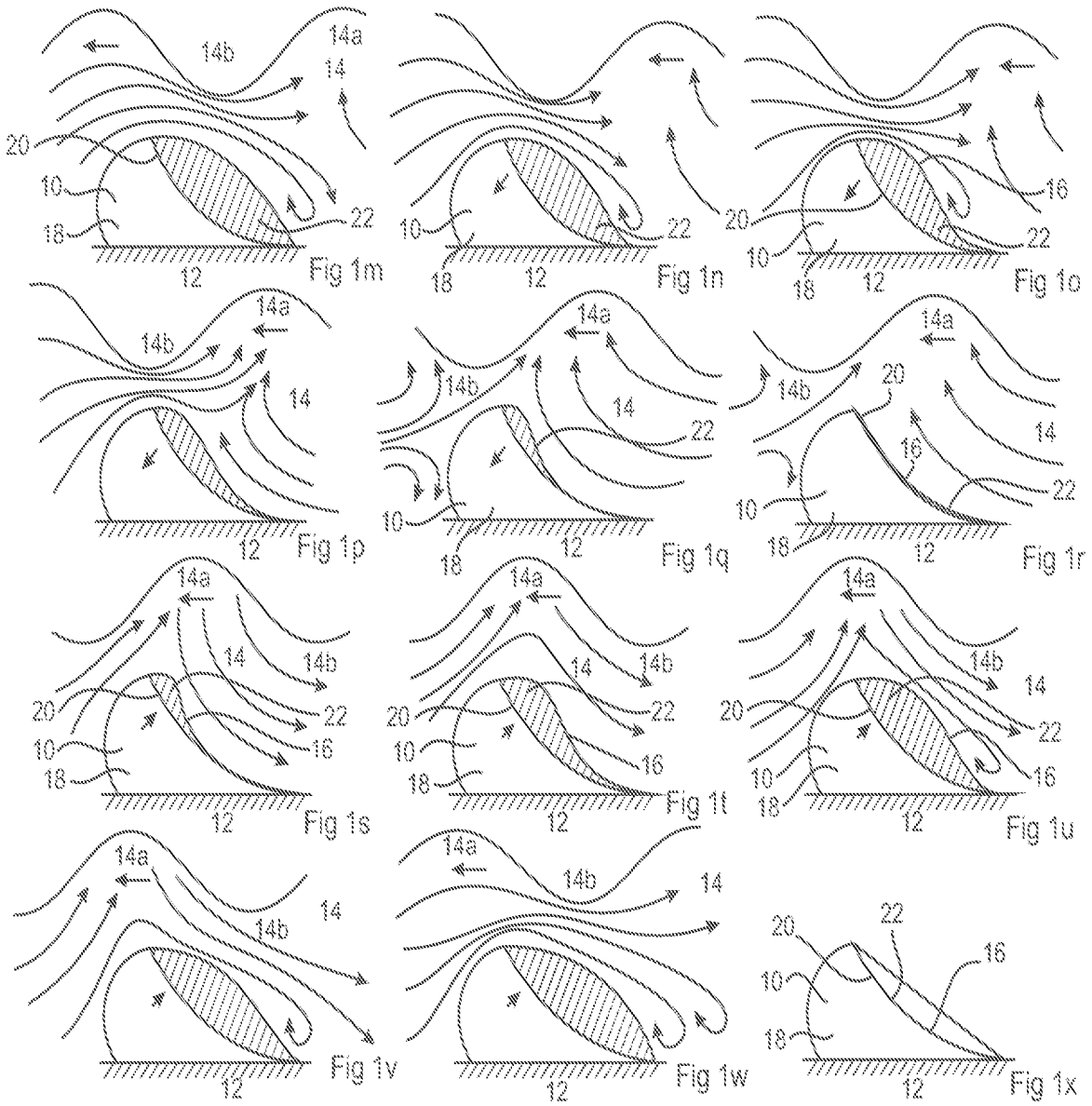

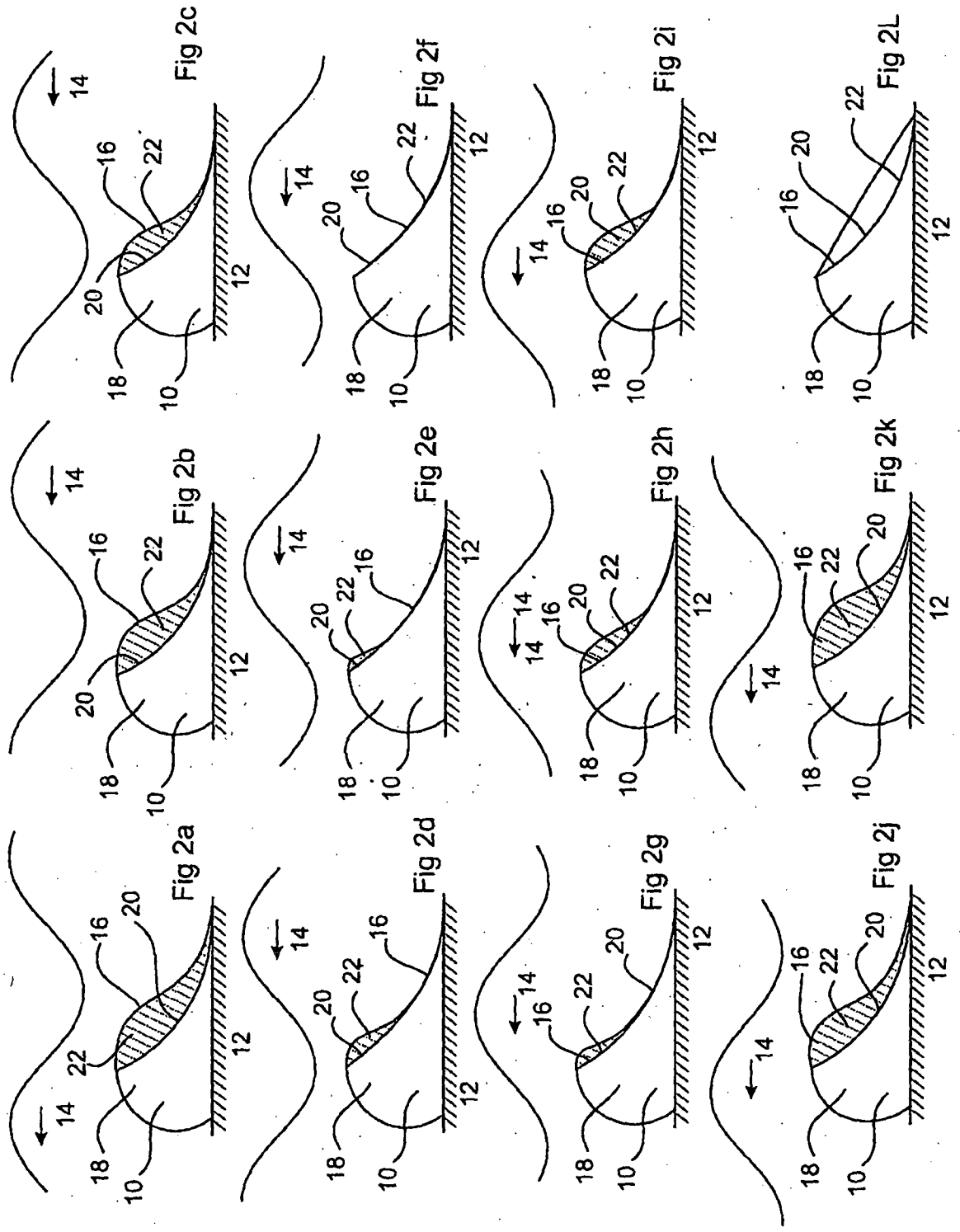

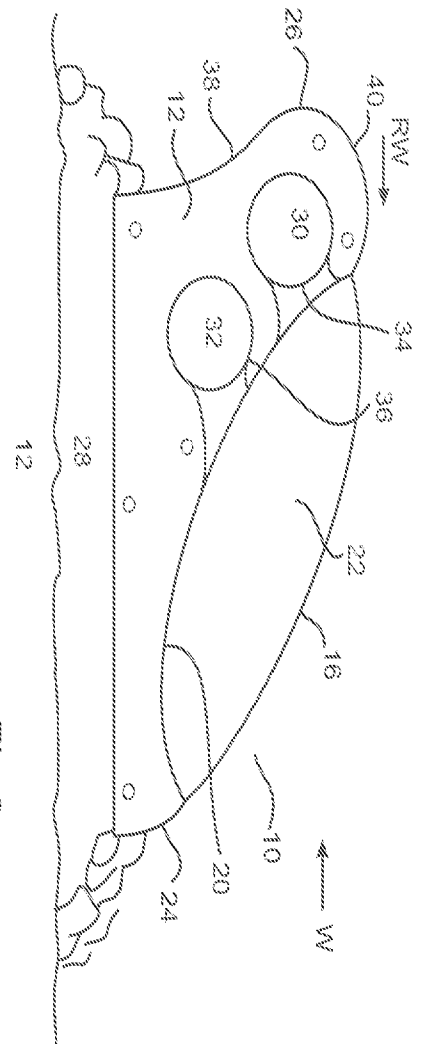

Fig 3

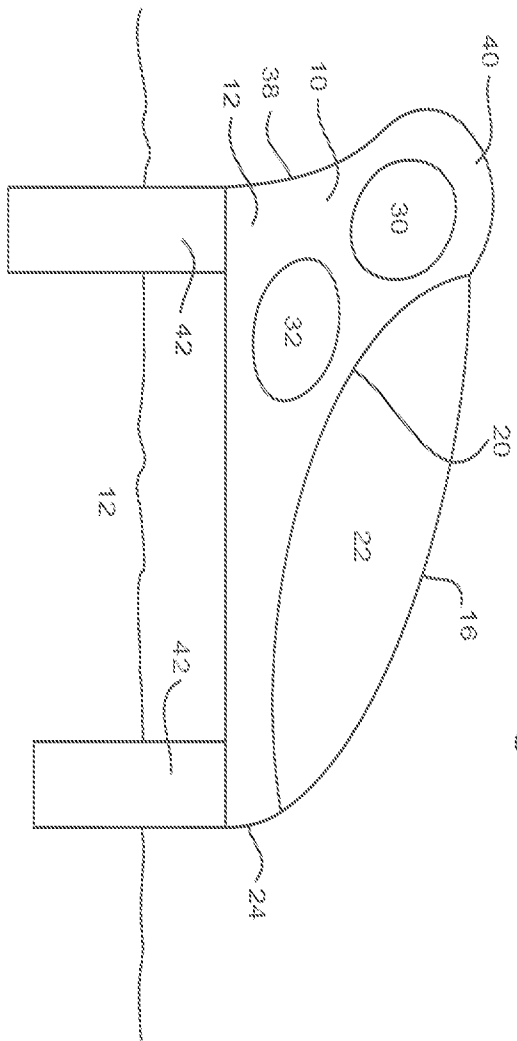

Fig 4

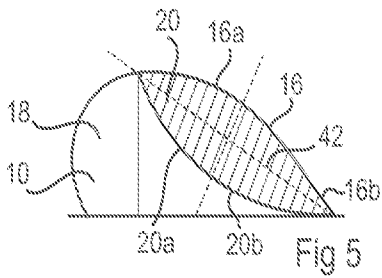

Fig 5

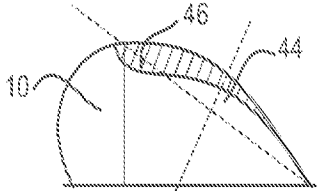

Fig 6a

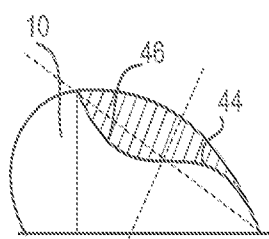

Fig 6b

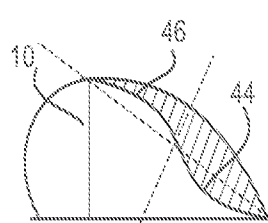

Fig 6c

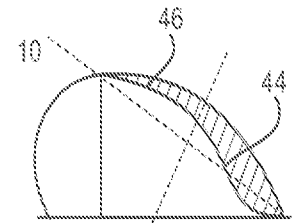

Fig 6d

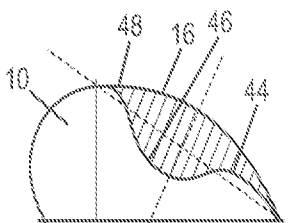

Fig 7a

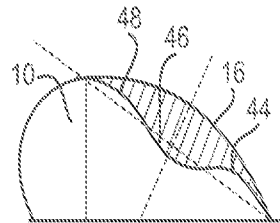

Fig 7b

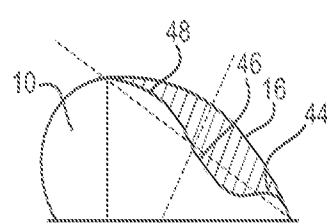

Fig 7c

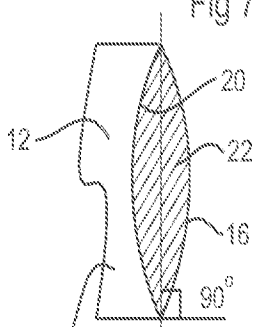

Fig 8a

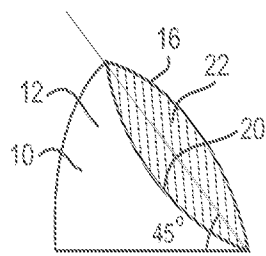

Fig 8b

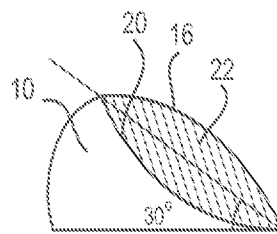

Fig 8c

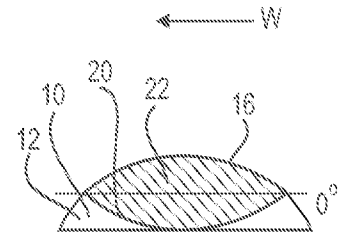
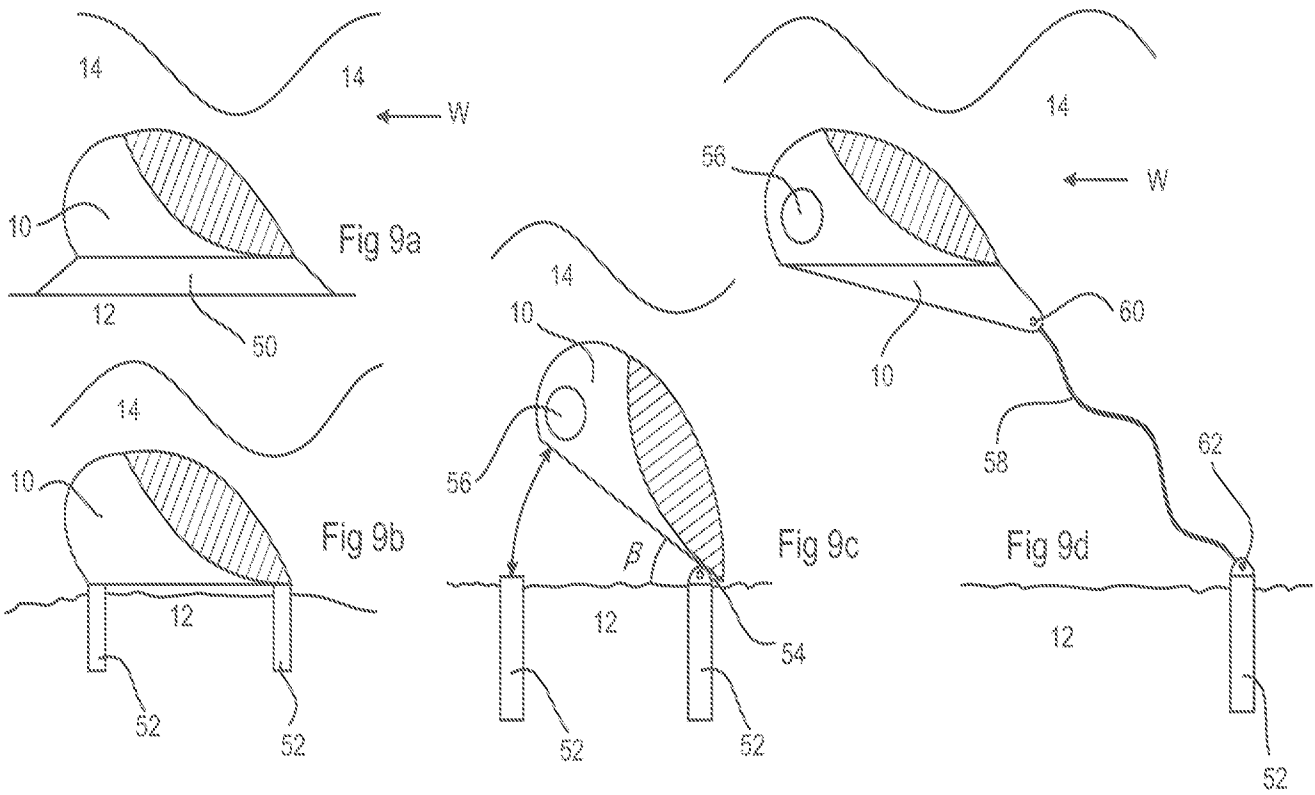
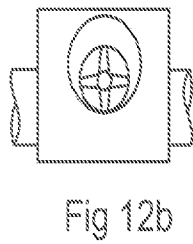
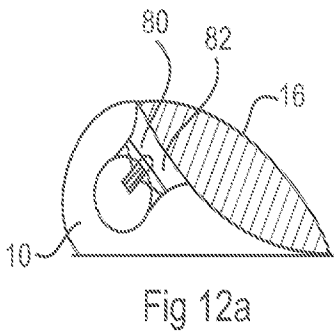
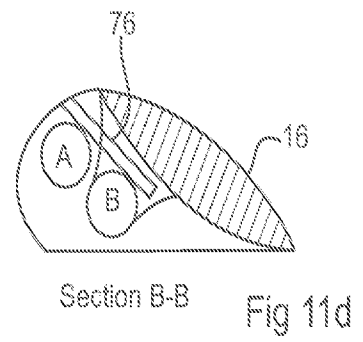
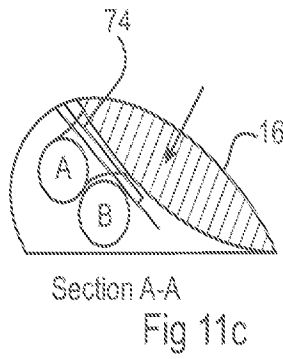
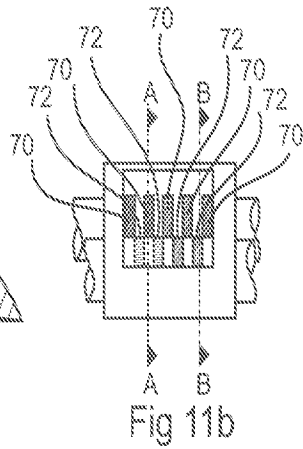
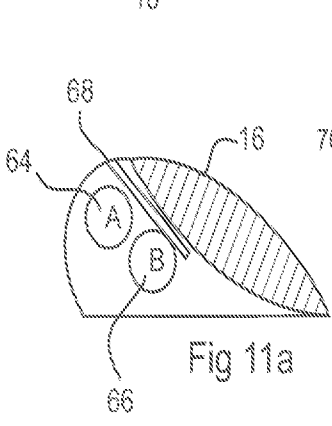
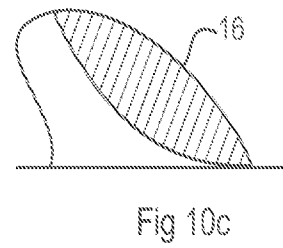
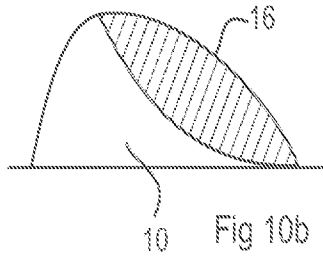
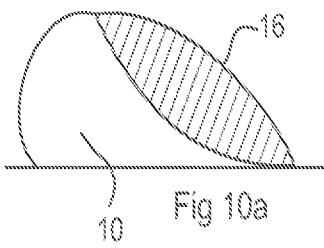

Fig 8d





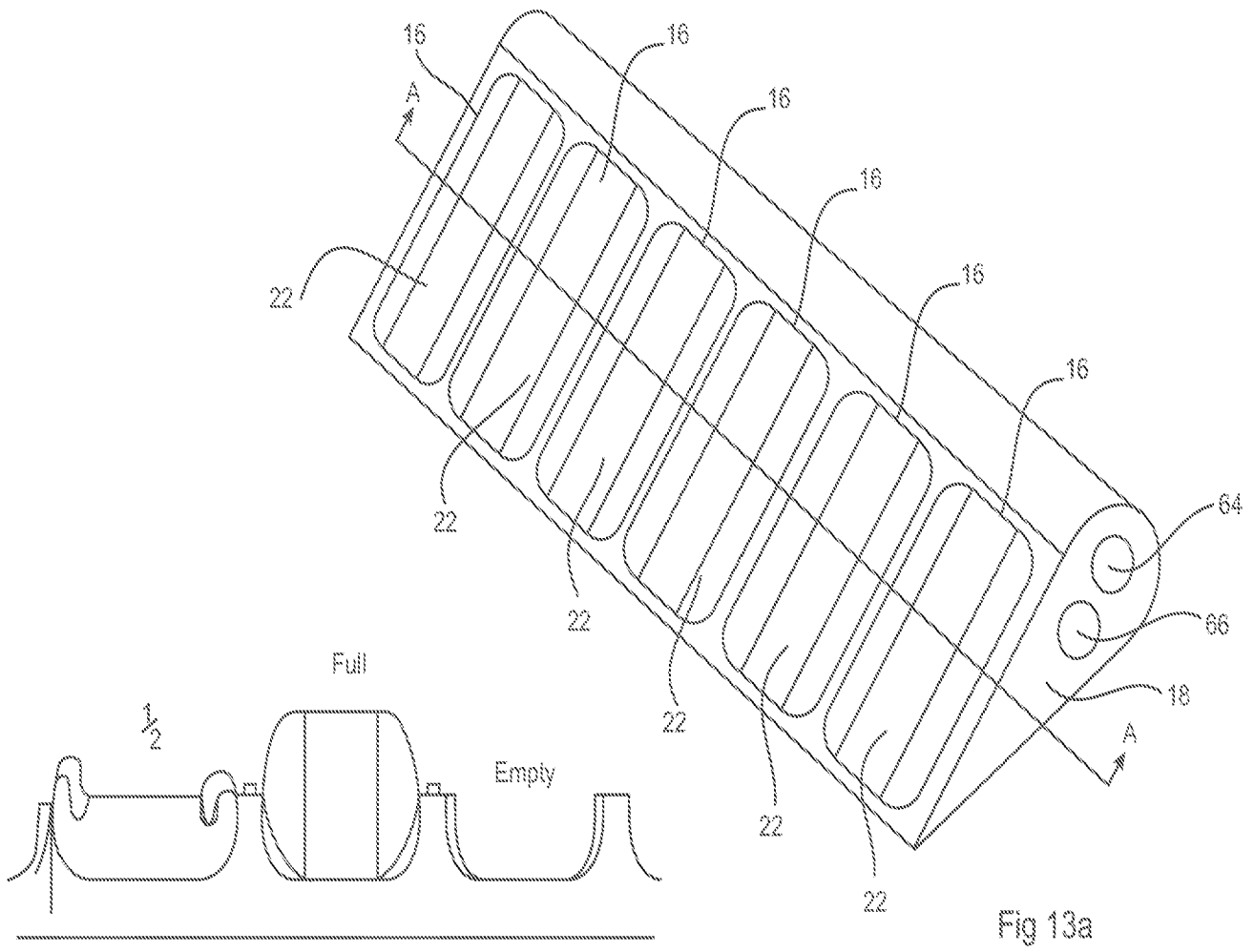

Fig 13a

Fig 13b

Section A-A

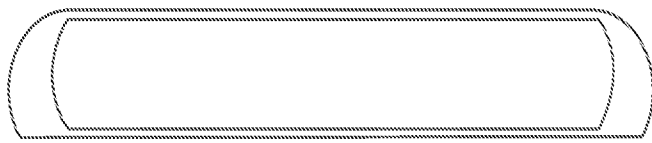

Fig 14a

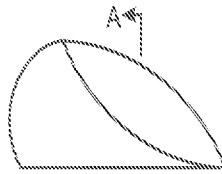

Fig 14b

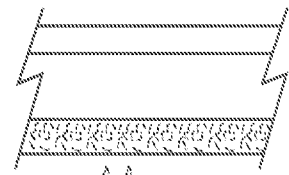

Fig 14c

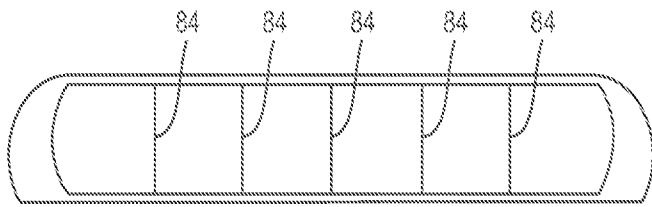

Fig 15a

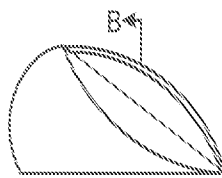

Fig 15b

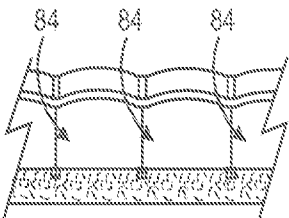

Fig 15c



Fig 16a

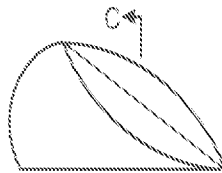

Fig 16b

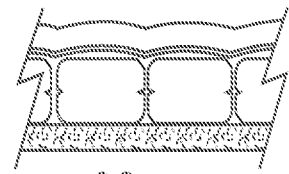

Fig 16c

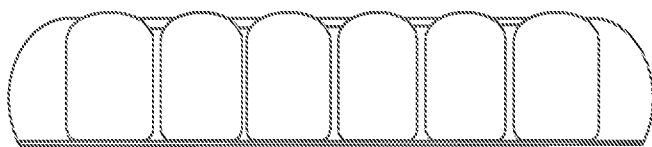

Fig 17a

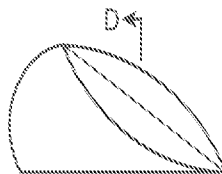

Fig 17b

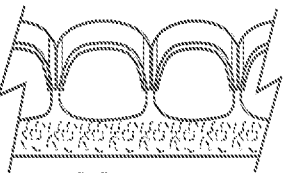

Fig 17c

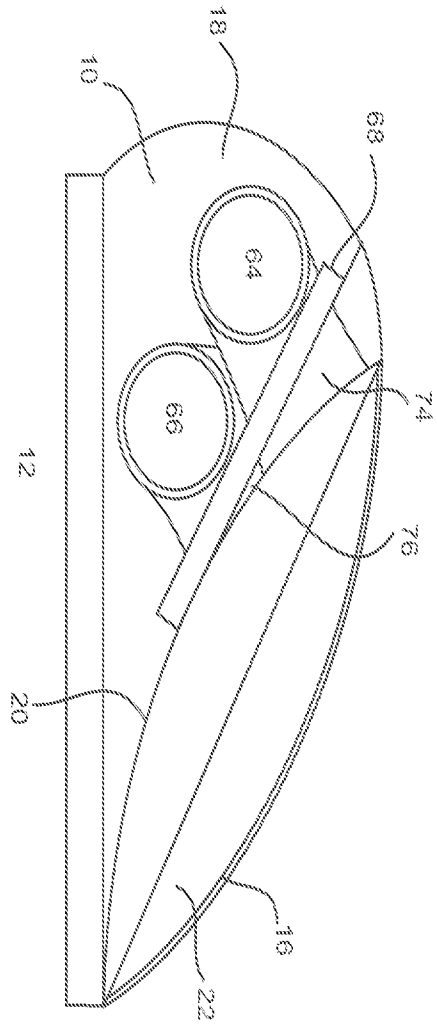

FIG 18

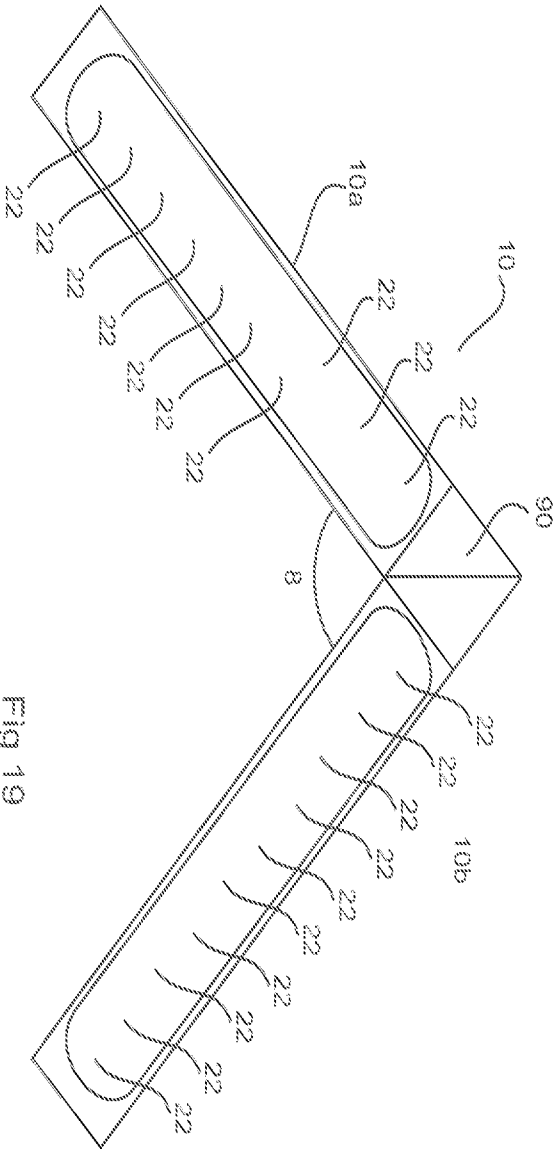

FIG 19

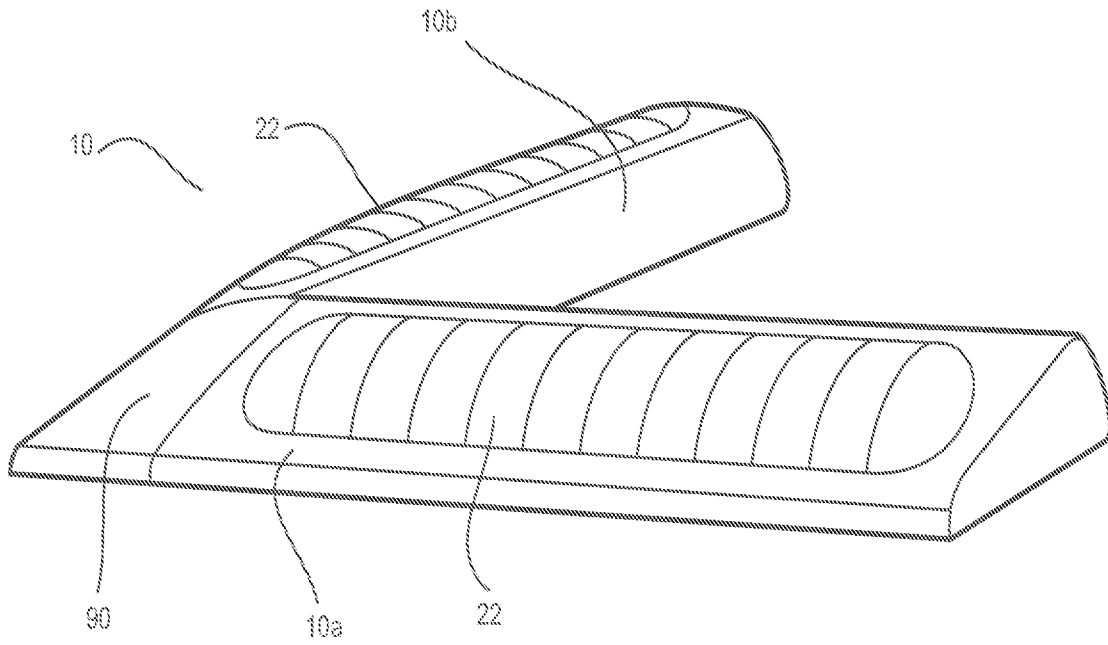

Fig 20

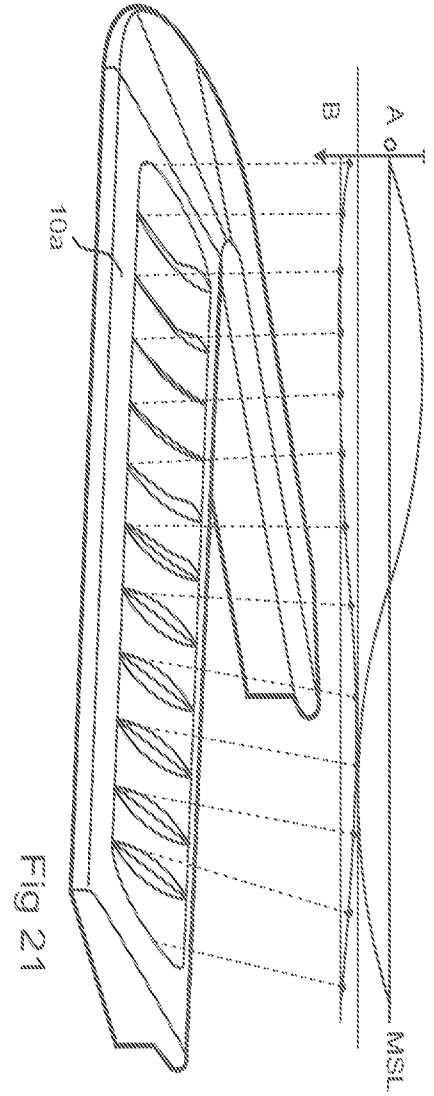
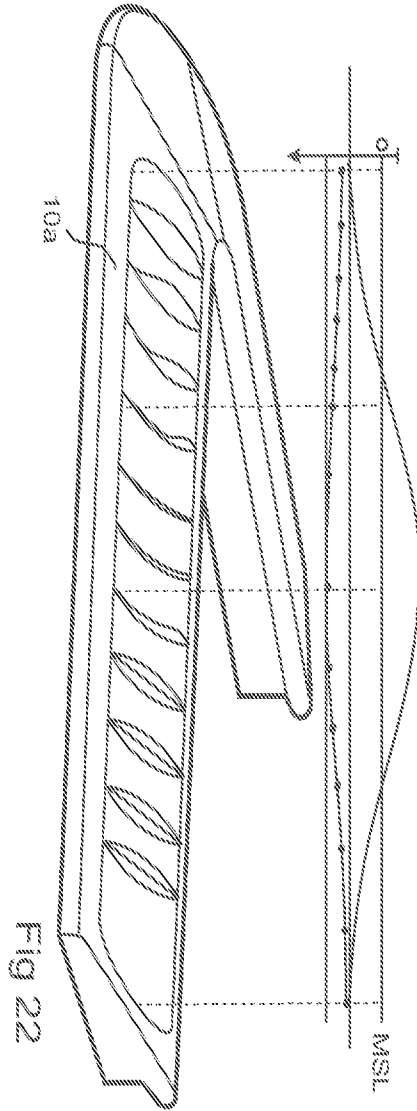
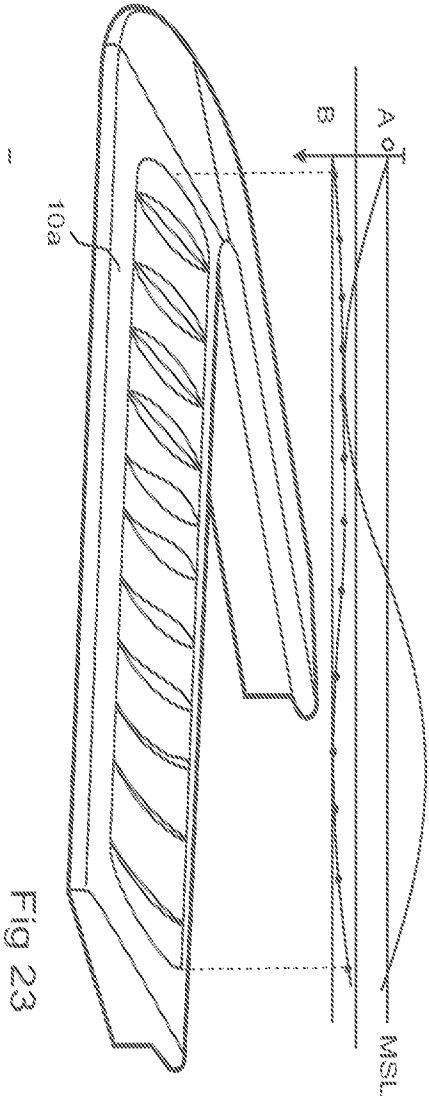

FIG 27

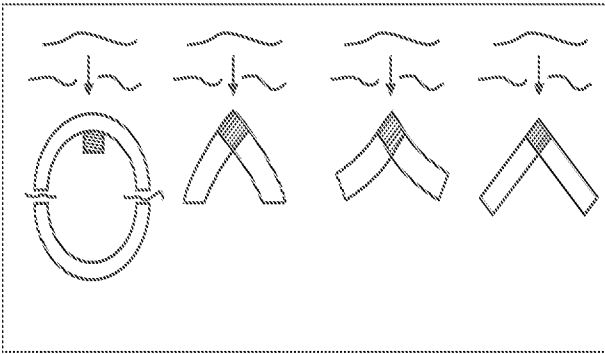

FIG 28

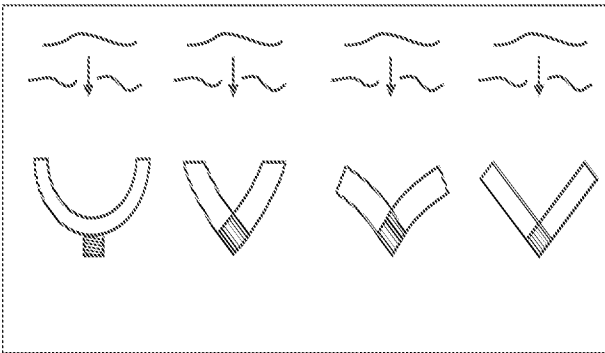

FIG 29

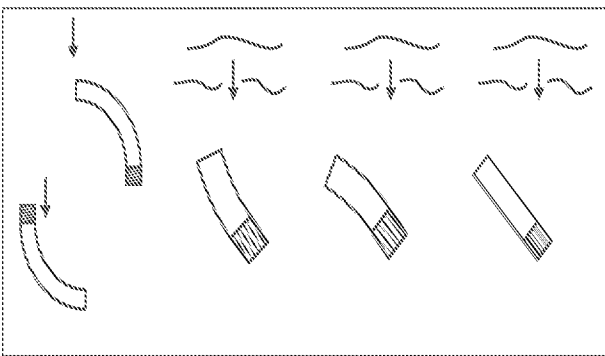

FIG 24

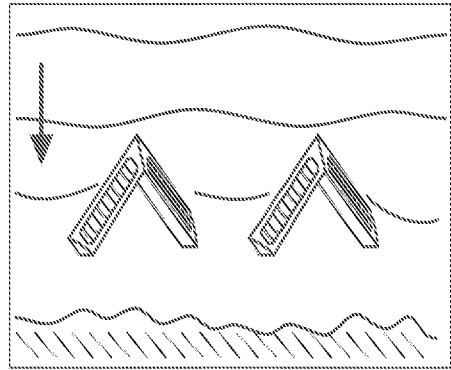

FIG 25

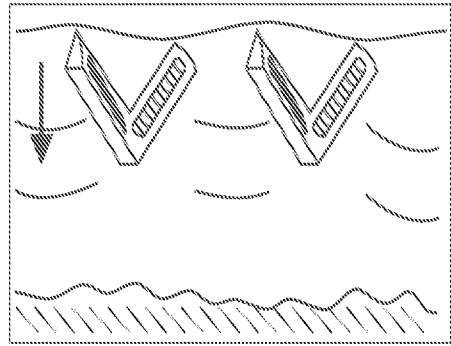
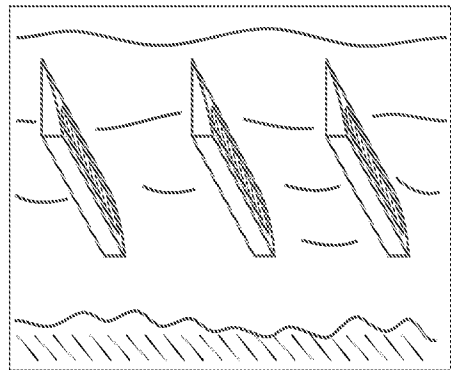
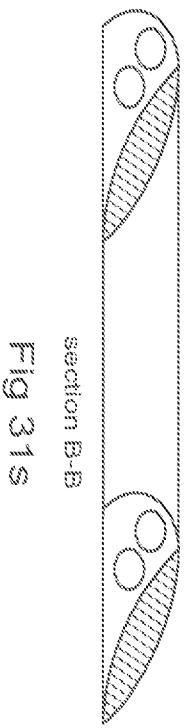
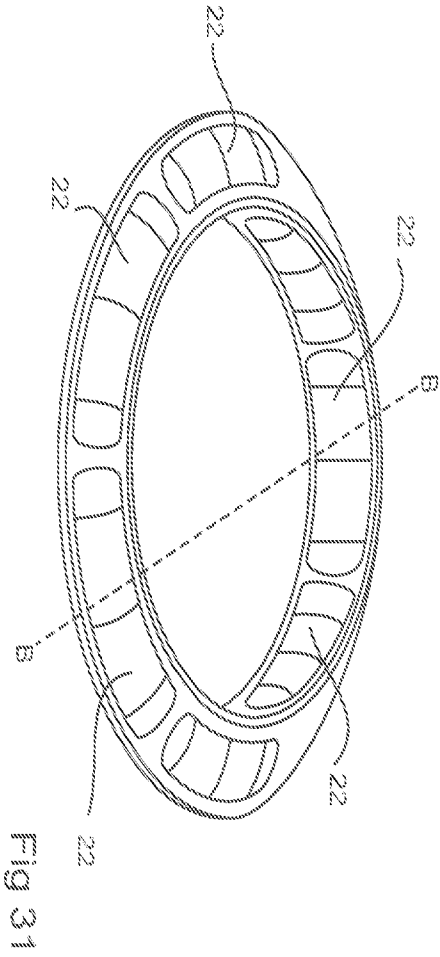
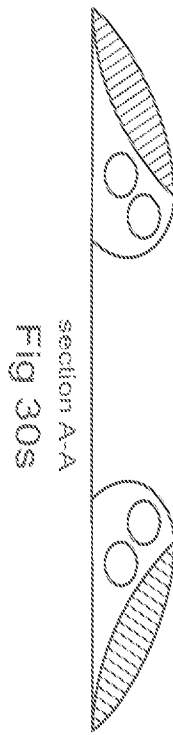
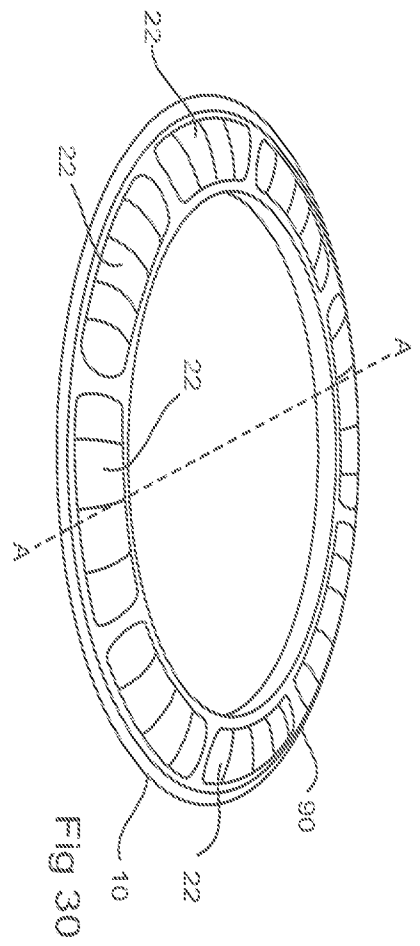
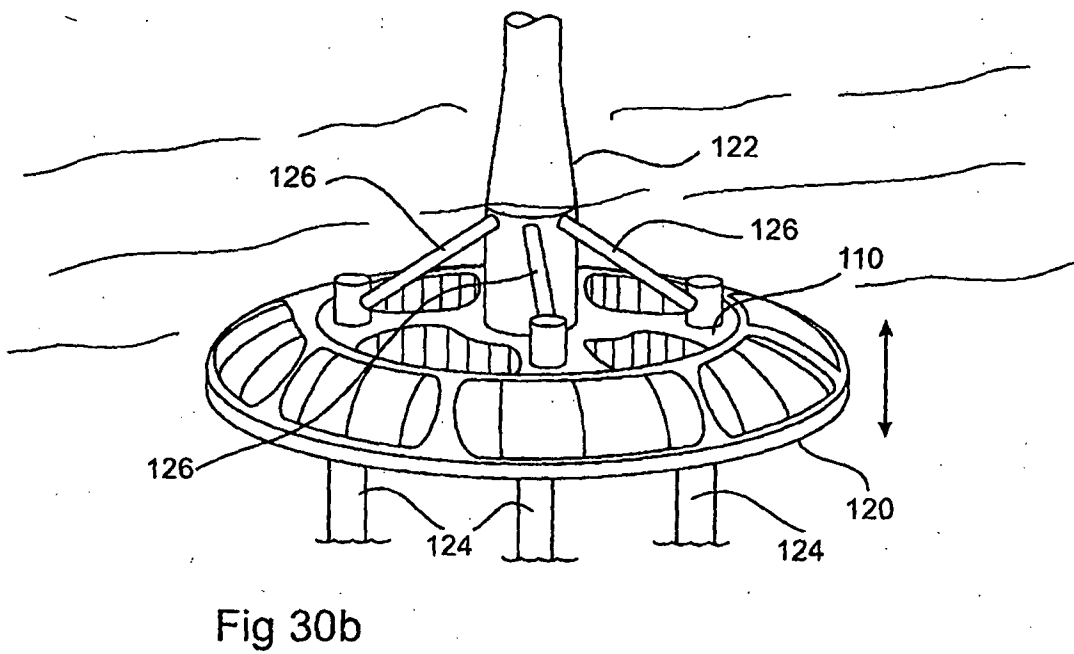
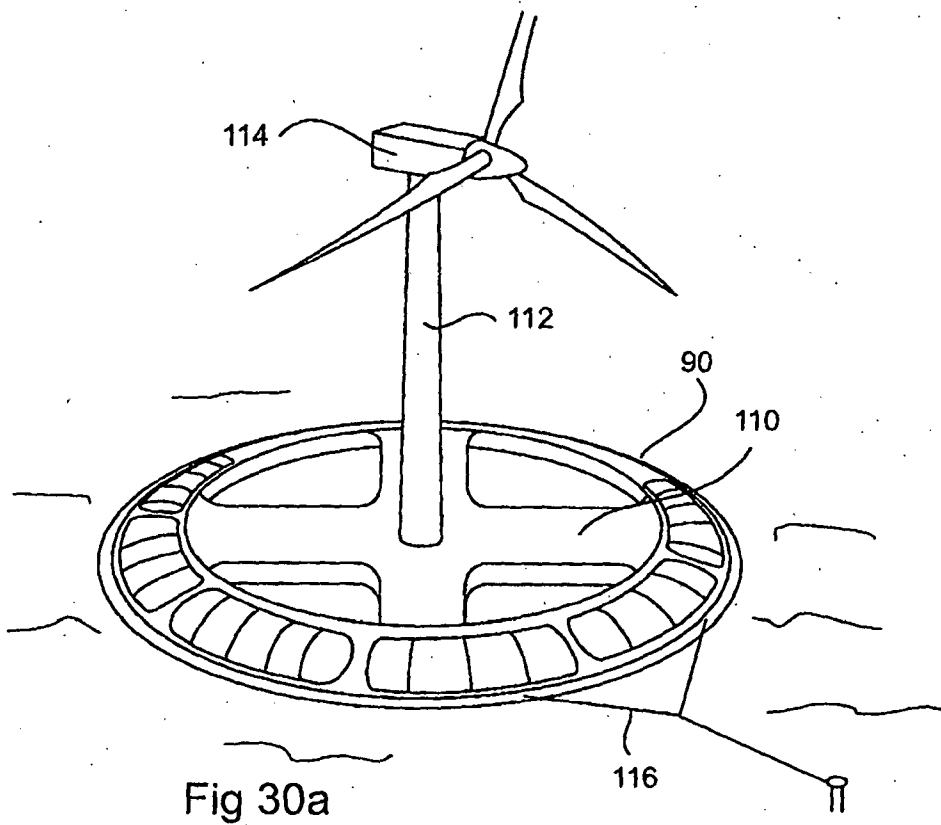
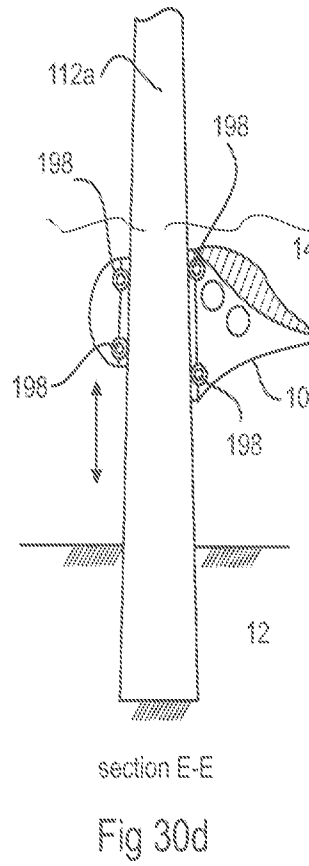
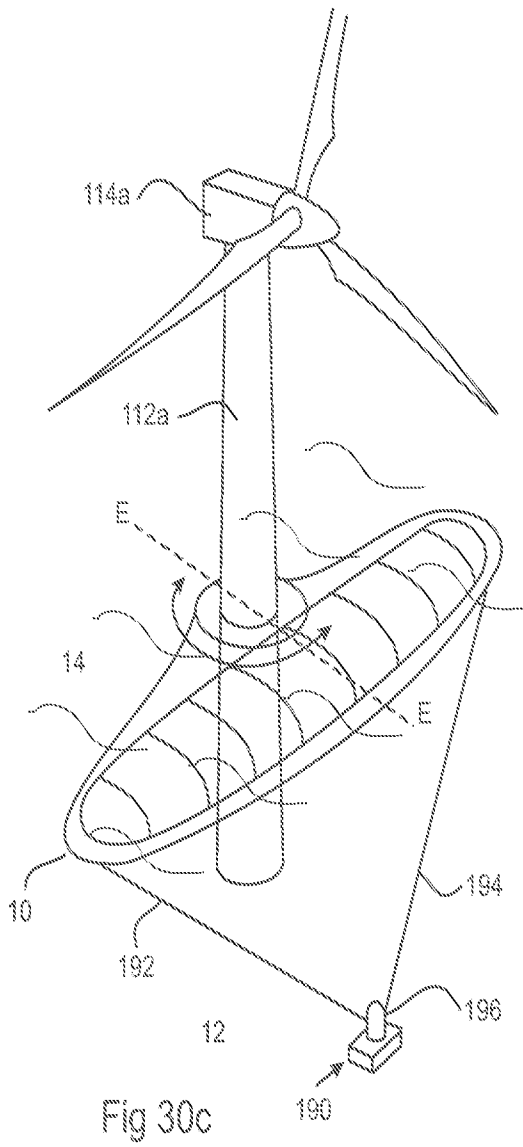

FIG 26









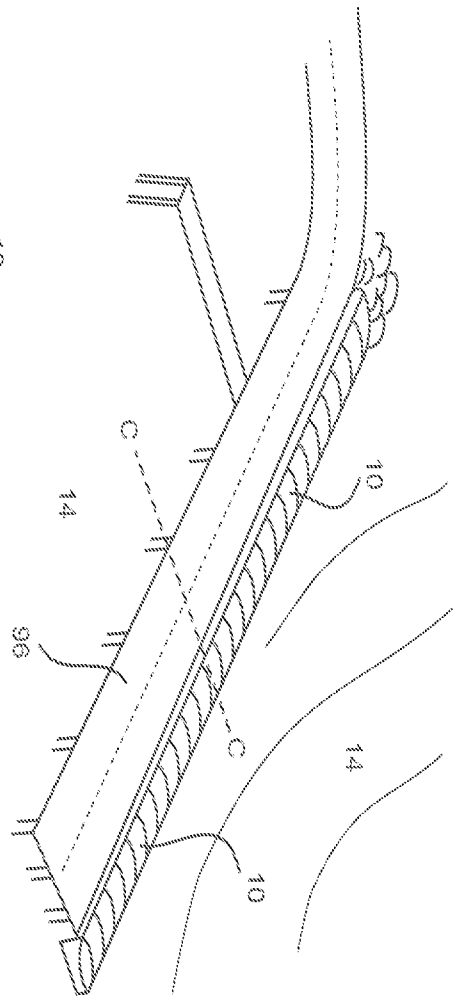

FIG 32

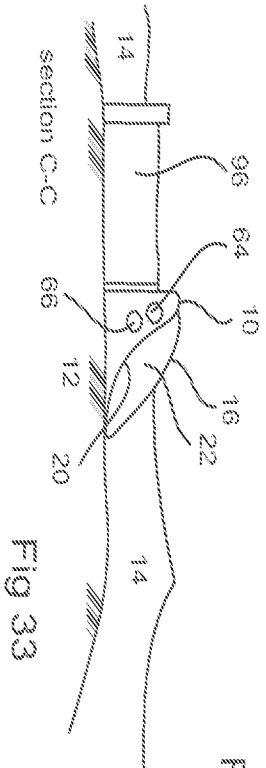

FIG 33

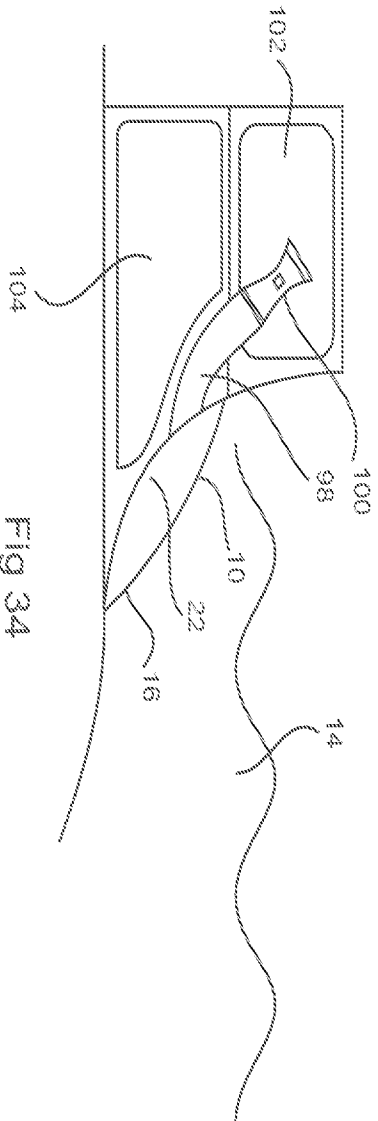
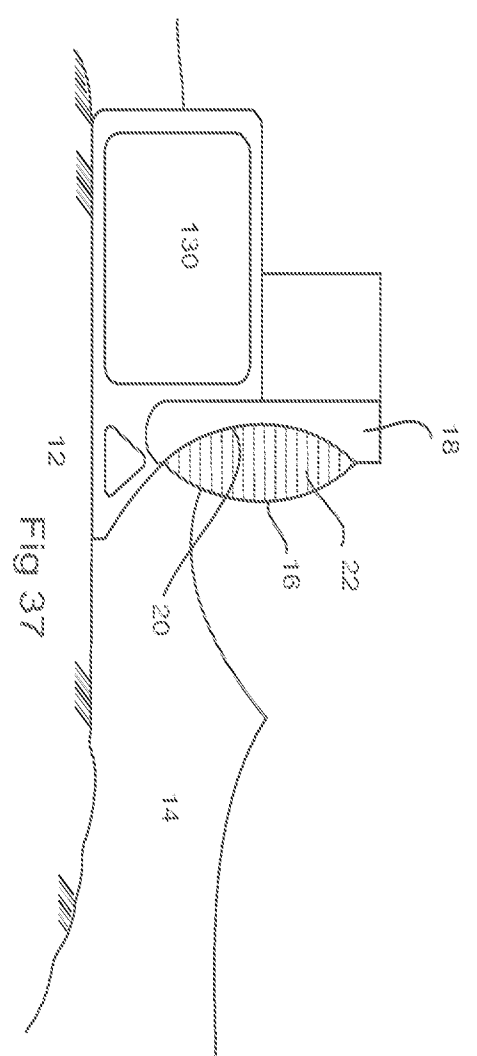
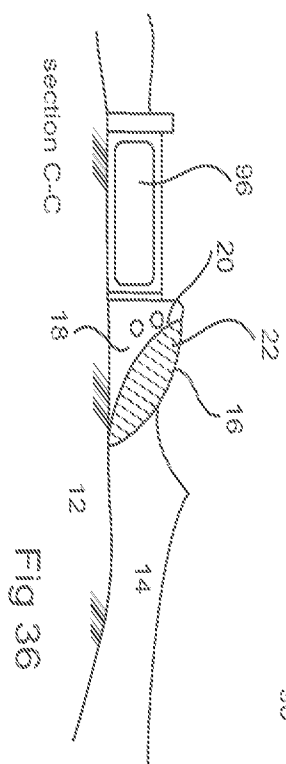
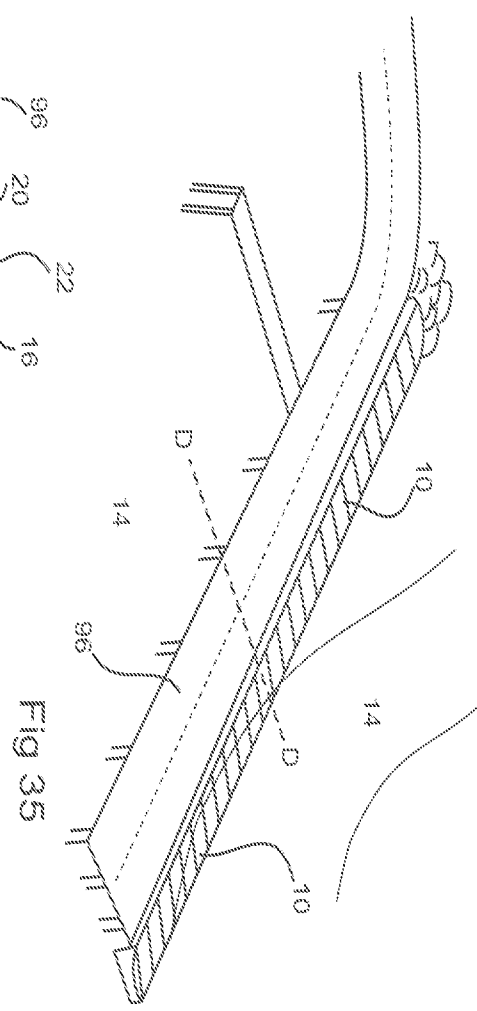

FIG 34



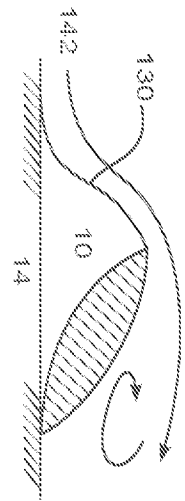
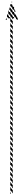

FIG 38

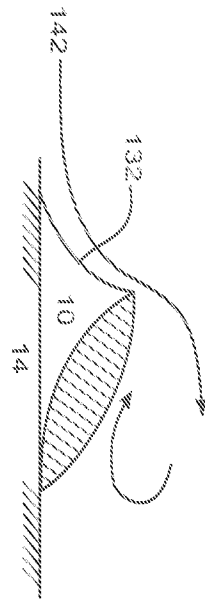

FIG 39

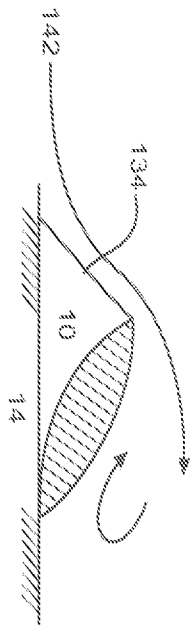

FIG 40

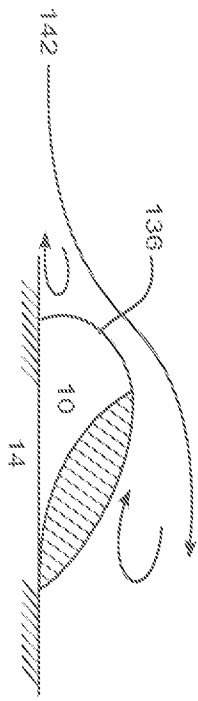

FIG 41



FIG 42

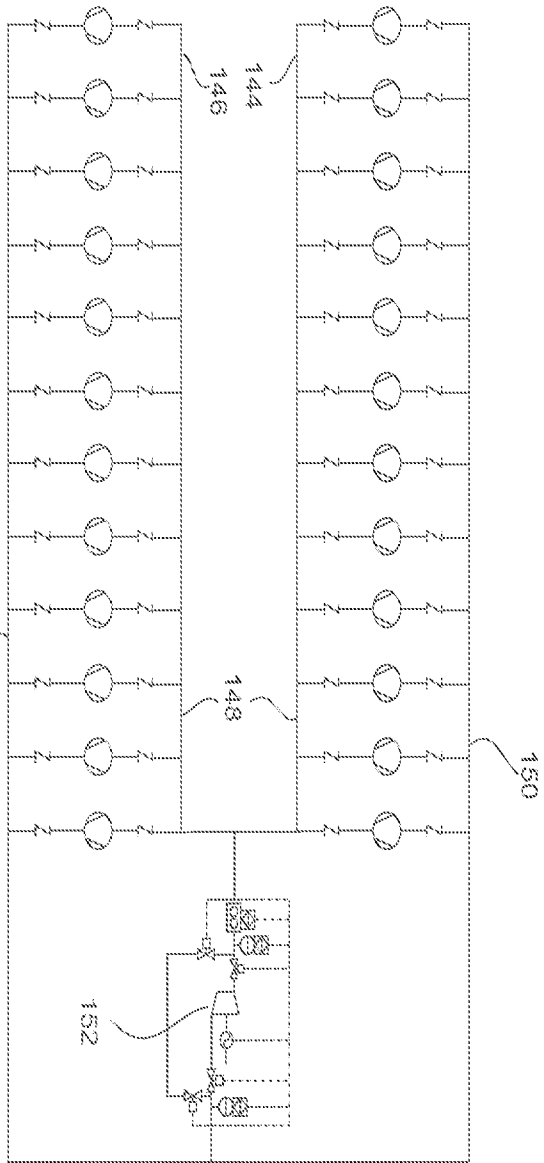

FIG 43

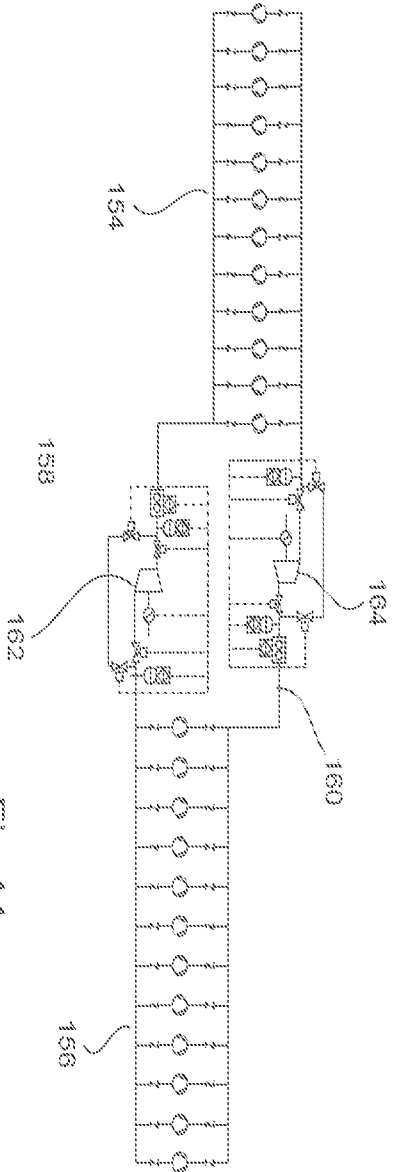
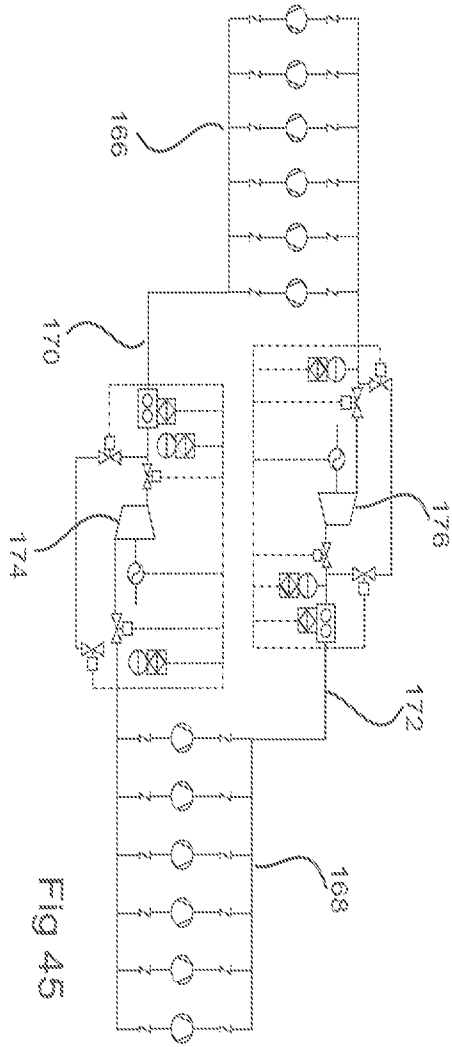
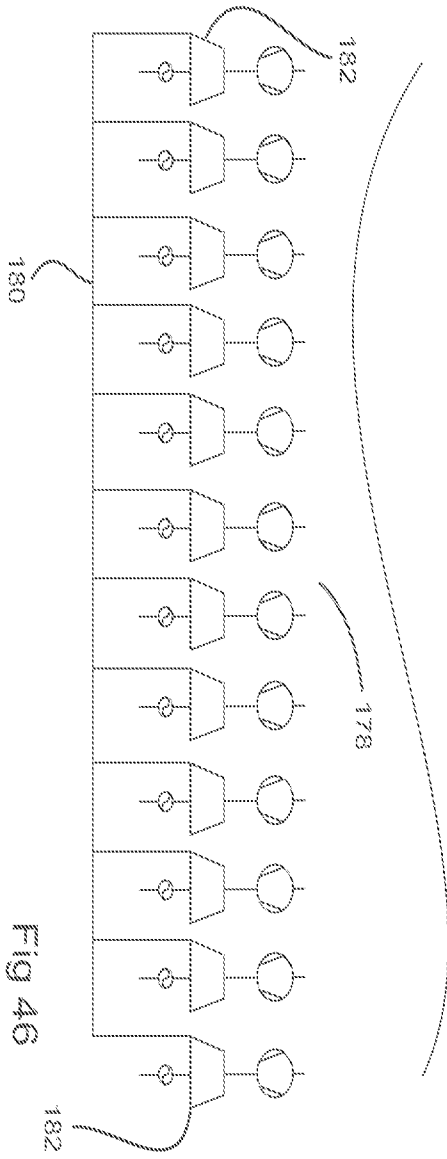

FIG 44



INTERNATIONAL SEARCH REPORT

International application No.
PCT/AU2013/000869**A. CLASSIFICATION OF SUBJECT MATTER****F03B 13/14(2006.01)i, F03B 13/12(2006.01)i**

According to International Patent Classification (IPC) or to both national classification and IPC

B. FIELDS SEARCHEDMinimum documentation searched (classification system followed by classification symbols)
F03B 13/14; F03B 13/18; E02B 9/08; F03B 13/24; F03B 13/12Documentation searched other than minimum documentation to the extent that such documents are included in the fields searched
Korean utility models and applications for utility models
Japanese utility models and applications for utility modelsElectronic data base consulted during the international search (name of data base and, where practicable, search terms used)
eKOMPASS(KIPO internal) & Keywords: wave, convert, membrane, diaphragm, bag, flexible, cell, volume, pressure**C. DOCUMENTS CONSIDERED TO BE RELEVANT**

Category*	Citation of document, with indication, where appropriate, of the relevant passages	Relevant to claim No.
X Y A	WO 2012-095669 A1 (BELLAMY et al.) 19 July 2012 See page 12, line 5 - page 18, line 15; figures 4-8e.	1-22, 30-34, 44-52 40, 53 23-29, 35-39, 41-43 , 54-60
Y A	US 2012-0032446 A1 (ROHRER, JOHN W.) 9 February 2012 See paragraph [0033]; figure 7.	40, 53 1-39, 41-52, 54-60
A	US 2009-0001729 A1 (WINSLOE, RONALD MULOE) 1 January 2009 See paragraphs [0021]-[0031]; figures 1-3.	1-60
A	US 2011-0162357 A1 (BELLAMY et al.) 7 July 2011 See paragraphs [0090]-[0098]; figures 4,5.	1-60
A	US 2011-0185721 A1 (TURNER, DONALD MILNE) 4 August 2011 See paragraphs [106]-[111]; figures 1,2.	1-60

 Further documents are listed in the continuation of Box C. See patent family annex.

* Special categories of cited documents:

"A" document defining the general state of the art which is not considered to be of particular relevance

"E" earlier application or patent but published on or after the international filing date

"L" document which may throw doubts on priority claim(s) or which is cited to establish the publication date of citation or other special reason (as specified)

"O" document referring to an oral disclosure, use, exhibition or other means

"P" document published prior to the international filing date but later than the priority date claimed

"T" later document published after the international filing date or priority date and not in conflict with the application but cited to understand the principle or theory underlying the invention

"X" document of particular relevance; the claimed invention cannot be considered novel or cannot be considered to involve an inventive step when the document is taken alone

"Y" document of particular relevance; the claimed invention cannot be considered to involve an inventive step when the document is combined with one or more other such documents, such combination being obvious to a person skilled in the art

"&" document member of the same patent family

Date of the actual completion of the international search

04 November 2013 (04.11.2013)

Date of mailing of the international search report

04 November 2013 (04.11.2013)

Name and mailing address of the ISA/KR

Korean Intellectual Property Office
189 Cheongsu-ro, Seo-gu, Daejeon Metropolitan City,
302-701, Republic of Korea

Facsimile No. +82-42-472-7140

Authorized officer

HAN, Joong Sub

Telephone No. +82-42-481-5606

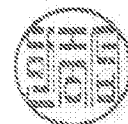

INTERNATIONAL SEARCH REPORT

Information on patent family members

International application No.

PCT/AU2013/000869

Patent document cited in search report	Publication date	Patent family member(s)	Publication date
WO 2012-095669 A1	19/07/2012	GB 201100446 D0	23/02/2011
US 2012-0032446 A1	09/02/2012	US 2013-0113211 A1 WO 2013-033667 A1 WO 2013-033685 A1	09/05/2013 07/03/2013 07/03/2013
US 2009-0001729 A1	01/01/2009	AU 2005-267676 A1 AU 2005-267676 B2 CA 2612658 A1 CA 2612658 C EP 1792017 A1 EP 1792017 A4 NO 20071145 A NZ 534415 A US 7554216 B2 WO 2006-011817 A1 ZA 200701650 A	02/02/2006 29/07/2010 02/02/2006 29/03/2011 06/06/2007 25/04/2012 28/02/2007 25/11/2005 30/06/2009 02/02/2006 28/05/2008
US 2011-0162357 A1	07/07/2011	EP 2300708 A2 GB 0809732 D0 GB 0816172 D0 GB 2460303 A WO 2009-144468 A2 WO 2009-144468 A3	30/03/2011 09/07/2008 15/10/2008 02/12/2009 03/12/2009 28/10/2010
US 2011-0185721 A1	04/08/2011	AU 2009-247839 A1 AU 2009-247839 A2 CA 2724168 A1 EP 2288806 A2 GB 0808667 D0 JP 2011-521147 A WO 2009-138740 A2 WO 2009-138740 A3	19/11/2009 16/12/2010 19/11/2009 02/03/2011 18/06/2008 21/07/2011 19/11/2009 04/11/2010