

M. R. WARD.
 CURTAIN POLE.
 APPLICATION FILED FEB. 9, 1911.

999,923.

Patented Aug. 8, 1911.

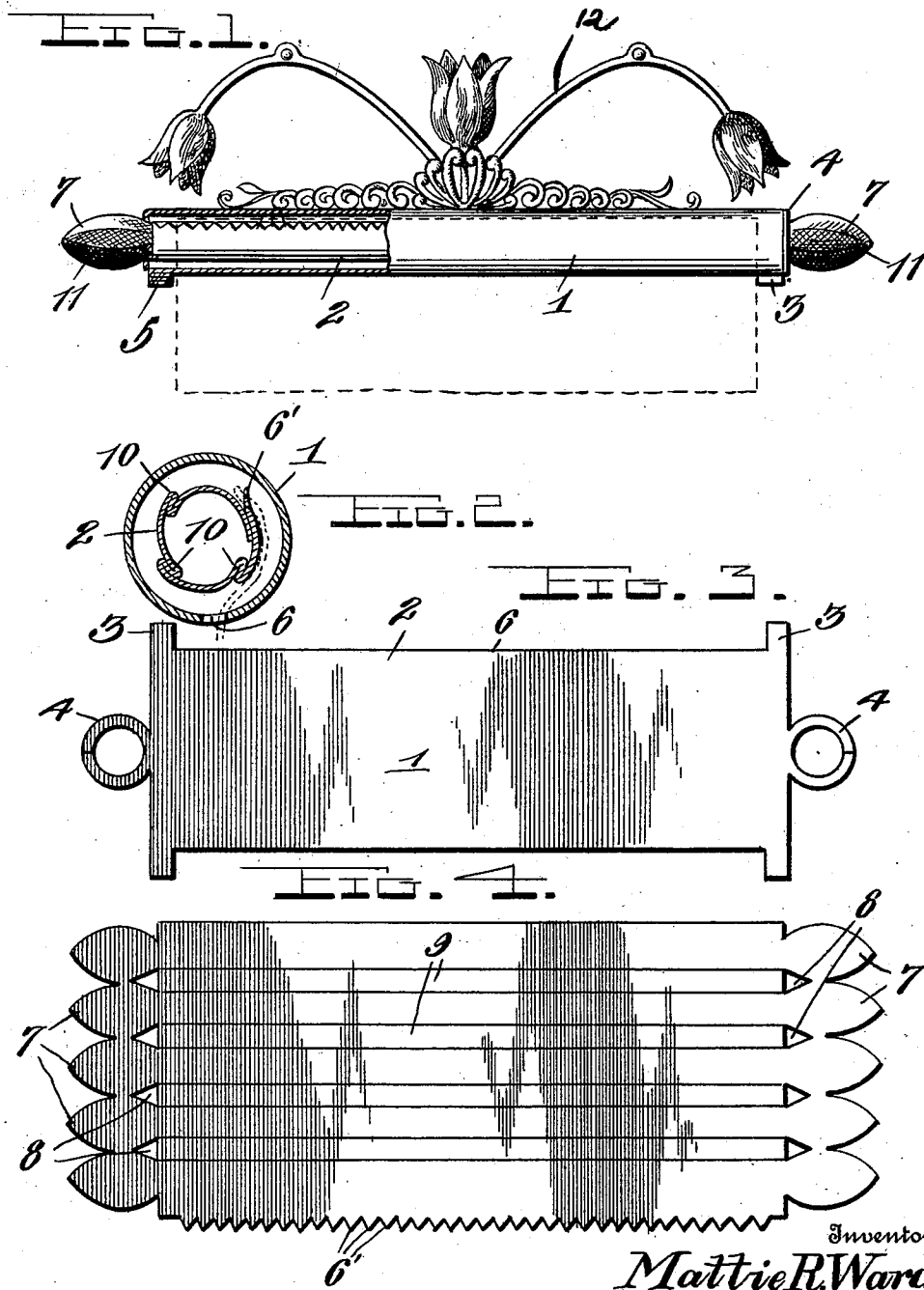

Inventor
Mattie R. Ward,

Witnesses
Chas. L. Griesbauer.
H. A. McQuay.

By *Watson E. Coleman,*
 Attorney

UNITED STATES PATENT OFFICE.

MATTIE R. WARD, OF LEESVILLE, LOUISIANA.

CURTAIN-POLE.

999,923.

Specification of Letters Patent.

Patented Aug. 8, 1911.

Application filed February 9, 1911. Serial No. 607,575.

To all whom it may concern:

Be it known that I, MATTIE R. WARD, a citizen of the United States, residing at Leesville, in the parish of Vernon and State of Louisiana, have invented certain new and useful Improvements in Curtain-Poles, of which the following is a specification, reference being had to the accompanying drawings.

This invention is an improved curtain pole and consists in the construction, combination and arrangement of devices hereinafter described and claimed.

The object of my invention is to provide an improved device of this character which may be readily and cheaply manufactured, from sheet metal, and which comprises an outer tubular member and an inner tubular member to which the curtain is directly attached, the outer member serving to conceal the inner member and part of the curtain attached thereto, a further object of the invention being to provide an improved curtain pole which renders it unnecessary to employ rings, pins or other like devices, to attach the curtain to the pole.

In the accompanying drawings—Figure 1 is partly an elevation and partly a longitudinal sectional view of a curtain pole constructed in accordance with my invention. Fig. 2 is a transverse sectional view of the same. Fig. 3 is a plan of the blank from which the outer tubular member is formed. Fig. 4 is a similar view of the blank from which the inner tubular member is formed.

In the construction of my improved curtain pole, I provide an outer tubular member 1, and an inner tubular member 2. The outer member 1 is made from a blank of sheet metal such as shown in Fig. 3, the said blank being rectangular in form with laterally extending projections 3, at its corners, and provided at its ends at points midway between its sides with integral outwardly extending open rings 4. The blank is rolled in tubular form so as to bring the projections 3 together, and the said projections are bent to form inter-engaging hooks 5, which secure the sides of the blank together, and the space between the said hooks forms a longitudinal slot 6 in one side of the member 1. The open rings 4 are bent to form heads or closures for the ends of the outer tubular member, and they also form bearings for the inner tubular member 2.

The inner tubular member is made from a

blank of sheet metal such as shown, in Fig. 4, which blank is provided on one longitudinal side with serrations or teeth 6, and is formed at its ends with segments 7, and with openings 8 between the inner ends of the segments. This blank is disposed in tubular form and is creased on the lines 9 at the sides of the openings 8, and doubled and overlapped between the said creases at 10, and the segments 8 are thus caused to be so related as to form knobs 11 at the ends of the inner tubular member. The seams or joints between the segments of the knobs may be soldered, and the side edges of the inner member may also be soldered together, with the serrated edge outermost so that the serrations 6' project tangentially from the said inner tubular member.

The curtain is attached to the inner tubular member by being engaged with the serrations 6' and is partly rolled upon the inner tubular member, and extends through the longitudinal slot in the lower side of the outer tubular member. It will be understood that the inner tubular member is concealed in and by the outer tubular member, excepting the knobs of the inner tubular member which project from the ends of the outer tubular member, and that portion of the curtain which is attached to the inner tubular member, is also entirely covered or concealed by the outer tubular member. A suitable hanger 12 is shown in Fig. 1, attached to the outer tubular member and adapted to be secured as by means of nails or the like to a window head, but within the scope of my invention, any suitable means may be employed to support the outer tubular member, and I wish it to be understood that I am not limited in this respect.

Since the curtain is attached directly to the inner member of the pole by the serrations of the latter, and the inner member of the pole is inclosed by the outer member thereof, and concealed thereby, no pins, rings or other like devices are necessary in attaching the curtain to the pole, and moreover the pole presents an exceedingly slightly and attractive appearance.

My improved curtain pole is entirely constructed of sheet metal excepting the vine loop which is shown in Fig. 1 attached to the upper side of the pole. This vine loop is made of wire and serves as a convenient hanger to support the curtain pole from the upper side of a window frame, so that lace

curtains may be hung away from the window. This vine loop hanger enables me to dispense with the use of brackets in attaching the pole to the top of a frame.

5 My improved curtain pole is artistic and attractive in design, may be made either corrugated or plain, and may be made of cheap or of costly material, and hence may be manufactured cheaply or expensively as
10 may be required by different tastes and to suit different classes of people, and may be colored, as desired and to match the trimmings of the room, the furniture or the curtain in connection with which the pole is
15 used.

No rings or other similar devices are required to attach the curtain to my improved pole as it is only necessary to insert the upper end of the curtain through the slot 6 and engage it with the serrations 6' of the inner tubular member and to then turn the inner tubular member so as to partly roll the curtain thereon. No screws, tacks, nails or other like devices are employed in the manufacture of my curtain pole or in securing
25 any of the parts thereof together. The knobs 7 being formed integral with the inner tubular member, cannot come off and these knobs are highly ornamental and attractive in appearance. The serrations 6'
30 which engage the curtain do not tear or soil the same and since the inner tubular member is revoluble in the outer tubular member, the curtain may be readily attached or
35 removed at will. The pole may be readily secured at the head of a window and may be readily removed therefrom.

I claim:—

40 1. The herein described curtain pole comprising a tubular outer member having a longitudinal slot in one side and provided at its ends with closures each having an open-

ing, and an inner member extending through, revoluble and having its bearings in the closures in the ends of the outer member. 45

2. The herein described curtain pole comprising a tubular outer member having a longitudinal slot in one side and provided at its ends with closures each having an opening, and an inner member extending through, revoluble and having its bearings in the closures in the ends of the outer member, said tubular inner member having curtain attaching devices and being provided
55 at its ends with enlargements which project beyond the ends of the outer member.

3. A curtain pole comprising a tubular member formed of sheet metal, having longitudinal creases, longitudinally extending
60 overlapped portions between the creases, and provided at its ends with knob segments, and openings between the bases of the knob segments, the said creases of the said member being coincident with the sides of said openings, and the said overlapped portions of
65 said member bringing the sides of said openings together, so that the diameter of the said tubular member is less than that of the knobs thereof. 70

4. A curtain pole comprising a tubular member formed from a blank of sheet metal provided at its ends with open rings forming closures for the ends of said tubular member, in combination with an inner member extending through the outer tubular member, and also through the said open rings thereof. 75

In testimony whereof I hereunto affix my signature in the presence of two witnesses. 80

MATTIE R. WARD.

Witnesses:

A. G. WARD,
J. H. CAIN.