



(43) International Publication Date
30 January 2014 (30.01.2014)

- (51) International Patent Classification:
B29C 67/00 (2006.01)
- (21) International Application Number:
PCT/IB2013/001621
- (22) International Filing Date:
25 July 2013 (25.07.2013)
- (25) Filing Language: Italian
- (26) Publication Language: English
- (30) Priority Data:
VI2012A000183 27 July 2012 (27.07.2012) IT
- (71) Applicant: DWS S.R.L. [IT/IT]; via Lago Di Levico, 3, I-36010 Zane' (VI) (IT).
- (72) Inventor: COSTABEBER, Ettore, Maurizio; Via Lage di Levico, 1, I-36010 Zane' (VI) (IT).
- (74) Agent: BONINI, Ercole; Studio Bonini SRL, Corso Fogazzaro, 8, I-36100 Vicenza (IT).
- (81) Designated States (unless otherwise indicated, for every kind of national protection available): AE, AG, AL, AM, AO, AT, AU, AZ, BA, BB, BG, BH, BN, BR, BW, BY, BZ, CA, CH, CL, CN, CO, CR, CU, CZ, DE, DK, DM,

DO, DZ, EC, EE, EG, ES, FI, GB, GD, GE, GH, GM, GT, HN, HR, HU, ID, IL, IN, IS, JP, KE, KG, KN, KP, KR, KZ, LA, LC, LK, LR, LS, LT, LU, LY, MA, MD, ME, MG, MK, MN, MW, MX, MY, MZ, NA, NG, NI, NO, NZ, OM, PA, PE, PG, PH, PL, PT, QA, RO, RS, RU, RW, SC, SD, SE, SG, SK, SL, SM, ST, SV, SY, TH, TJ, TM, TN, TR, TT, TZ, UA, UG, US, UZ, VC, VN, ZA, ZM, ZW.

(84) Designated States (unless otherwise indicated, for every kind of regional protection available): ARIPO (BW, GH, GM, KE, LR, LS, MW, MZ, NA, RW, SD, SL, SZ, TZ, UG, ZM, ZW), Eurasian (AM, AZ, BY, KG, KZ, RU, TJ, TM), European (AL, AT, BE, BG, CH, CY, CZ, DE, DK, EE, ES, FI, FR, GB, GR, HR, HU, IE, IS, IT, LT, LU, LV, MC, MK, MT, NL, NO, PL, PT, RO, RS, SE, SI, SK, SM, TR), OAPI (BF, BJ, CF, CG, CI, CM, GA, GN, GQ, GW, KM, ML, MR, NE, SN, TD, TG).

Published:

- with international search report (Art. 21(3))
- before the expiration of the time limit for amending the claims and to be republished in the event of receipt of amendments (Rule 48.2(h))

(54) Title: CARTRIDGE FOR A STEREO LITHOGRAPHIC MACHINE, STEREO LITHOGRAPHIC MACHINE COMPRISING SAID CARTRIDGE AND METHOD OF MANUFACTURING SAID CARTRIDGE

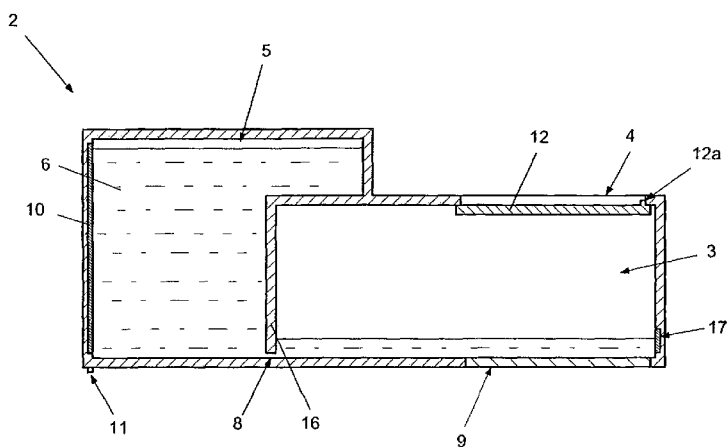

FIG. 1

(57) Abstract: The invention is a cartridge (2; 2'; 2'') for a stereolithography machine (1), comprising: a container (3) provided with an access opening (4); a reservoir (5) for containing a base material (6) suited to be solidified through exposure to a predefined radiation (7), the reservoir (5) being fixedly associated with the container (3); feeding means (8) suited to feed the base material (6) from the reservoir (5) towards the container (3). The bottom (9) of the container (3) is at least partially transparent to the predefined radiation (7) and is situated opposite the access opening (4).



CARTRIDGE FOR A STEREOLITHOGRAPHIC MACHINE, STEREOLITHOGRAPHIC MACHINE COMPRISING SAID CARTRIDGE AND METHOD OF MANUFACTURING SAID CARTRIDGE.

DESCRIPTION

5 The present invention concerns an interchangeable cartridge for a stereolithography machine.

As is known, the stereolithography technique makes it possible to produce a three-dimensional object by superimposing a plurality of layers of a base material, liquid or pasty, that is solidified through exposure to a predefined
10 radiation, generally of the luminous type.

A stereolithography machine of the known type comprises a container suited to contain the base material, the bottom of which is generally transparent to the predefined radiation.

The machine also comprises means suited to emit said predefined radiation,
15 arranged under the container, which selectively solidify the layer of base material that is adjacent to the bottom of the container.

The solidified layers are supported by a modelling platform, powered in the vertical direction so that it is possible to arrange the last solidified layer adjacent to said layer of base material before it solidifies.

20 The stereolithography machines of the known type pose the drawback that they require that the container be periodically topped up, so as to restore the level of the base material that is consumed during the process.

If said topping up operation is carried out manually, there is the drawback that the operator must be exposed to the base material, with consequent risks
25 deriving from the possible toxicity of the latter.

According to a known variant embodiment, the topping up operation is carried out automatically but in this case the stereolithography machine must be provided with a feeding device, which involves a cost and requires maintenance.

30 A further drawback of the machines constructed according to this variant embodiment derives from the fact that, when it is necessary to change the base material, said feeding device must be washed in such a way as to avoid any contamination between the old and the new base material.

In any case, the machines described above pose the further drawback that the
35 base material that remained in the container at the end of the processing cycle

is exposed to the atmospheric agents, in particular to the air and light of the surrounding environment, with the consequence that it progressively deteriorates until it becomes unusable.

To avoid said deterioration, it is necessary to manually transfer the remained
5 material into a container and keep it there until it is used again.

However, this operation poses drawbacks that are analogous to those already described with regard to the manual topping up of the container.

A further drawback posed by the stereolithography machines of the known type is connected to the fact that, during the processing cycle, the transparent
10 bottom of the container is exposed to the predefined radiation and thus progressively becomes opaque.

Said opacifying action progressively reduces the effectiveness of the radiation, until it becomes necessary to replace the container.

The determination of the time when it is necessary to carry out said
15 replacement requires a certain amount of expertise.

The difficulties related to the topping up and emptying of the container, the periodical replacement of the container and the possible washing of the feeding system mean that a machine of the type described above is not suited to be used by an inexperienced user.

20 The present invention aims to overcome all the drawbacks which are typical of the stereolithography machines of the known type described above.

In particular, it is a first object of the invention to eliminate the need to periodically top up and/or empty the container.

It is a further object of the invention to avoid the need to wash the container
25 feeding system.

It is also the object of the invention to facilitate the replacement of the container when the bottom of the container has become opaque.

It is another, yet not the least object of the invention to avoid the deterioration of the base material that has remained at the end of the processing cycle.

30 The above mentioned objects are achieved by a cartridge for a stereolithography machine constructed according to claim 1.

Said objects are also achieved by a method for producing the cartridge of the invention according to claim 14, as well as by a stereolithography machine comprising the cartridge, according to claim 15.

35 Further characteristics and details of the various aspects of the invention are

described in the corresponding dependent claims.

Advantageously, the stereolithography machine of the invention is particularly suited to be used even by an inexperienced operator like, for example, an operator of the goldworking or dentistry sector.

5 The said objects and advantages, together with others which will be highlighted below, are illustrated in the description of a preferred embodiment of the invention which is provided by way of non-limiting example with reference to the attached drawings, wherein:

- Figure 1 shows a side sectional view of the cartridge of the invention;
- 10 - Figure 2 shows the cartridge of Figure 1 during use in a stereolithography machine;
- Figure 3 shows a side sectional view of a variant embodiment of the cartridge of Figure 1;
- Figure 4 shows a side sectional view of a further variant embodiment of the
15 cartridge of Figure 1.

The cartridge for a stereolithography machine that is the subject of the invention, indicated as a whole by **2** in Figure 1, comprises a container **3** provided with an access opening **4**.

20 The opening **4** is suited to allow a modelling platform **14** of a stereolithography machine **1** to be inserted in the container **3** when the cartridge **2** is connected to said stereolithography machine **1**, as shown in Figure 2.

The cartridge **2** also comprises a reservoir **5** suited to contain a base material **6**, liquid or pasty, suited to be solidified through exposure to a predefined radiation **7**.

25 Preferably but not necessarily, said base material **6** is a light-hardening resin or a photopolymer and the predefined radiation **7** is light.

Said reservoir **5** is permanently associated with the container **3** in such a way as to form a single body with it.

30 Preferably, the container **3** and the reservoir **5** belong to a single containment structure, which comprises an intermediate wall **16** that separates the container **3** from the reservoir **5**.

The cartridge **2** comprises also feeding means **8** suited to transfer the base material **6** from the reservoir **5** towards the container **3**.

35 According to the invention, the container **3** has a bottom **9** that is at least partially transparent to the predefined radiation **7** and is situated opposite the

access opening **4** of the container **3**.

The configuration of the access opening **4** and of the transparent bottom **9** makes it possible to use said cartridge **2** in a stereolithography machine **1** to replace the containers of the known type.

5 In fact, the transparent bottom **9** allows the passage of the predefined radiation **7** to obtain the solidification of the base material **6** contained in the container **3**. Furthermore, the access opening **4** allows the modelling platform **14** to be inserted in the container **3** and to be moved so that the stereolithography processing can be performed.

10 The reservoir **5** can be previously filled with base material **6** that, through the feeding means **8**, is transferred into the container **3** as it is used during the processing cycle, so as to maintain the level of the base material **6** in the container **3** substantially constant.

Therefore, the container **3** does not need to be topped up from the outside, at least until the base material **6** in the reservoir **5** has completely run out, and thus one of the objects of the invention is achieved.

In particular, to advantage, the cartridge **2** described above does not require any topping up to be performed by the operator, nor automatic feeding devices to be installed on the machine, which simplifies both the stereolithography machine **1** and its use.

20 Furthermore, as the feeding means **8** are incorporated in the cartridge **2**, there is no need to wash them if the base material for the processing cycle has to be changed, and thus another object of the invention is achieved.

In fact, the base material can be modified by simply replacing the cartridge **2** with another analogous cartridge containing the new base material.

25 Preferably, the reservoir **5** is provided with means suited to insulate the base material **6** contained therein from the external environment.

Advantageously, said insulation effect makes it possible to protect the base material **6** contained in the reservoir **5** from the air and/or light of the surrounding environment.

30 Preferably, said insulation means comprise tight walls that delimit the reservoir **5**.

In particular, the walls of the reservoir **5** are preferably opaque to the light of the surrounding environment.

35 Regarding the feeding means **8**, these are preferably configured in such a way

as to maintain the level of the base material **6** in the container **3** within a predefined interval, independently of the level of the base material **6** present in the reservoir **5**.

Advantageously, this makes it possible to constantly maintain the level in the container **3** at an optimal value for processing, at the same time avoiding possible leakages of the base material **6** through the container **3**.

Preferably, said feeding means **8** comprise a properly sized orifice that connects the reservoir **5** to the container **3**.

In particular, said orifice can be configured in such a way as to allow the spontaneous outflow of the base material **6** when the level in the container **3** lowers and stop it once said level has been restored to its initial value.

The effect described above can be obtained, for example, by sizing the orifice in such a way as to exploit the different pressures acting on the base material **6** present in the reservoir **5** and in the container **3**, as well as capillarity through the orifice.

According to the variant embodiment of the invention shown in Figure 3 and indicated by **2'** therein, said feeding means **8** comprise valve means **19** suited to be controlled so as to allow or prevent the outflow of the base material **6** from the reservoir **5** to the container **3** according to the level of the base material **6** present in the latter.

Preferably, said valve means **19** comprise an air valve suited to allow air to get into the reservoir **5**.

According to a further variant embodiment illustrated in Figure 4, the feeding means **8** comprise a thrust device **18** suited to thrust the base material **6** from the reservoir **5** towards the container **3**.

In particular, said thrust device **18** is configured so that its action is inhibited as long as the level of the base material **6** in the container **3** remains within said predefined interval.

Preferably but not necessarily, said thrust device **18** is a pump.

Preferably, the cartridges **2'** and **2''** comprise power means **20** respectively suited to supply power to the valve means **19** and the thrust device **18**.

Preferably, said power means **20** comprise a power supply connector that can be associated with an analogous connector belonging to the stereolithography machine.

According to further variant embodiments of the invention, not illustrated in the

figures, the feeding means **8** may comprise a hole suited to be closed and to allow the removable connection to the reservoir **5** of external control means configured so as to control the outflow of the base material **6** towards the container **3**.

5. Said external control means may comprise, for example, valve means or a thrust device of the types described above.

In particular, the control means may belong to the stereolithography machine **1**.

Obviously, variant embodiments of the invention may comprise a combination of several feeding means selected among those described above.

Furthermore, in all the embodiments described above, the feeding means **8** may comprise sensors **17** suited to monitor the level of the base material **6** in the container **3** and to indicate any abnormal level.

In the last two embodiments, the sensors **17** can be operatively connected to the valve means **19** and/or the thrust device **18** in such a way as to control their action.

Preferably, the cartridge **2** also comprises means **10** suited to detect the level of the base material **6** contained in the reservoir **5**.

Said detection means **10** make it possible to warn the operator that the base material **6** contained in the reservoir **5** has run out, so that the operator can replace the cartridge **2** when appropriate.

Therefore, the detection means **10** advantageously make it possible to further facilitate the use of the stereolithography machine **1**.

Preferably, the detection means **10** are configured so as to emit an electric signal that represents the level of the base material **6** in the reservoir **5**.

Said electric signal is preferably transmitted to a device that is external to the cartridge **2** through connection means **11** that may comprise, for example, a first connector suited to be removably connected to a second connector belonging to the stereolithography machine **1**.

The stereolithography machine **1** is preferably equipped with warning means, not represented herein but known per se, configured in such a way that on receipt of said electric signal they can communicate to the operator that the base material **6** contained in the reservoir **5** has run out.

Preferably, the cartridge **2** comprises also a door **12** movably associated with the access opening **4** of the container **3** in such a way that it can assume a

closed position, shown in Figure 1, and an open position, shown in Figure 2.

Advantageously, closing said door **12** means making it possible to insulate the contents of the cartridge **2** completely from the external environment, for example during the periods when the cartridge **2** remains unused, in such a way as to preserve the base material **6**, achieving the object to avoid its deterioration.

Still advantageously, said door **12** avoids any accidental contact between the operator and the base material **6**, to further advantage of the ease of use of the machine.

10 Preferably, the door **12** is motorized, so that it spontaneously assumes the closed position.

Said motorization can be obtained, for example, through elastic means.

According to a variant embodiment, the motorization is obtained by means of a closing device belonging to the stereolithography machine.

15 In this case, means suited to lock the door **12** in the closed position can be provided, which are suited to prevent the operator from opening the door **12**.

Said requisite can be met, for example, by configuring said locking means so that they can be released only through a tool that is automatically operated by the stereolithography machine **1** before starting the processing cycle.

20 In any case, the door **12** preferably comprises a shaped portion **12a** suited to define the ends of stroke corresponding to said open and closed positions.

Preferably but not necessarily, the volume of the reservoir **5** is included between 1 cm^3 and 50 cm^3 .

25 The volume indicated above corresponds to the quantity of base material **6** necessary to produce a dental model of the type used in dental mechanics.

Advantageously, a cartridge **2** with a reservoir **5** in the size indicated above can be used as a disposable cartridge, further simplifying the use of the machine for an unskilled operator, while at the same time limiting the quantity of base material **6** to the indispensable minimum.

30 With regard to the transparent bottom **9** of the container **3**, this is preferably configured so that the energy, in the form of predefined radiation **7**, necessary to opacify it does not exceed 110% of the energy, in the form of the same predefined radiation **7**, necessary to solidify a quantity of base material **6** corresponding to the volume of the reservoir **5**.

35 In this way, the duration of the transparent bottom **9** is adapted to the base

material **6** contained in the reservoir **5**, with the advantage of limiting the cost of the transparent bottom **9** and, thus, of the cartridge **2**.

According to the method for producing said cartridge **2**, the reservoir **5** is preferably filled with base material **6** and the reservoir **5** and the container **3** are sealed.

Said sealing effect is obtained by packaging the cartridge **2** in a tight package that is opened by the operator before starting the processing cycle.

According to a variant embodiment of the invention, said sealing effect can be directly obtained through the walls of the cartridge **2**.

In particular, the reservoir **5** can be filled through a hole that, once the filling operation has been completed, is closed in a tight and preferably fixed manner. Furthermore, the door **12** can be configured in such a way as to ensure that the cartridge remains completely tight at least until the door is opened for the first time.

Operatively, the cartridge **2** is used on a stereolithography machine **1** comprising radiation emitting means **13** suited to emit the predefined radiation **7** and a modelling platform **14** associated with power means suited to move the platform **14** along a movement trajectory **X**.

The machine is provided with removable connection means **15** suited to house the cartridge **2** in an operating position that is schematically illustrated in Figure 2.

Advantageously, said connection means **15** allow the cartridge **2** to be easily installed on the stereolithography machine **1**, as well as to be easily removed once the cartridge **2** has been used up.

In particular, the operating position defined by the connection means **15** for the cartridge **2** is such that the transparent bottom **9** of the cartridge is arranged along the trajectory of said predefined radiation **7** and that the access opening **4** is arranged along said moving trajectory **X** of the platform **14**.

Preferably, the connection means **15** are provided with sensors, not illustrated in the figures but known per se, suited to detect the presence of the cartridge **2** and to indicate, if necessary, any positioning defect, thus further improving ease of use.

Once the cartridge **2** has been positioned on the machine **1**, the door **12** of the container **3** is opened, preferably automatically, in order to allow the modelling platform **14** to enter the container **3**.

Successively, the radiation emitting means **13** and the modelling platform **14** are operated in such a way as to obtain the three-dimensional object, according to the stereolithography methods known per se.

At the end of the processing cycle, the modelling platform **14** and, together with it, the finished object, are extracted from the container **3**.

Preferably, the movable door **12** of the container **3** is closed in such a way as to protect the base material **6** remained in the cartridge **2** from the atmospheric agents, so that it can be used again at a later moment.

The stereolithography machine **1** can be configured so that it warns the operator if the level of the base material **6** present in the reservoir **5** is below a predefined threshold before starting a successive processing cycle.

According to a variant embodiment, the stereolithography machine **1** is configured so that it can calculate the quantity of base material **6** necessary to make the object, comparing it with the quantity of base material **6** available in the reservoir **5**.

If the quantity of base material **6** available in the reservoir **5** is not sufficient, the stereolithography machine **1** warns the user.

The above clearly shows that the cartridge described above achieves all the set objects.

In particular, the presence of the reservoir and of the feeding means eliminates the need for the operator to periodically top up and/or empty the container of the cartridge.

Furthermore, easy connection and removal of the cartridge to/from the machine facilitate replacement when the bottom of the container becomes opaque.

Said ease of use is further enhanced by the presence of means for detecting the level of the base material present in the reservoir.

Ease of use is also favoured by the fact that it is not necessary to wash the container feeding system in the case where the base material must be changed, as the feeding system is incorporated in the cartridge.

Therefore, it is sufficient to replace the cartridge with an analogous cartridge containing the new base material.

Furthermore, the possibility to close the access opening of the cartridge of the invention makes it possible to preserve the material contained therein, preventing its untimely deterioration.

CLAIMS

1) Cartridge (2; 2'; 2'') for a stereolithography machine (1), comprising:

- a container (3) provided with an access opening (4);
- a reservoir (5) for containing a base material (6), liquid or pasty, suited to be solidified through exposure to a predefined radiation (7), said reservoir (5) being permanently associated with said container (3);
- feeding means (8) suited to feed said base material (6) from said reservoir (5) towards said container (3),

characterized in that the bottom (9) of said container (3) is at least partially transparent to said predefined radiation (7) and is situated opposite said access opening (4).

2) Cartridge (2; 2'; 2'') according to claim 1, **characterized in that** said reservoir (5) comprises means suited to insulate the base material (6) contained therein from the external environment.

3) Cartridge (2; 2'; 2'') according to any of the preceding claims, **characterized in that** said feeding means (8) are configured so as to maintain the level of said base material (6) contained in said container (3) within a predefined interval.

4) Cartridge (2') according to any of the preceding claims, **characterized in that** said feeding means (8) comprise valve means (19) suited to be controlled in such a way as to allow or prevent the outflow of said base material (6) from said reservoir (5) to said container (3).

5) Cartridge (2'') according to any of the preceding claims, **characterized in that** said feeding means (8) comprise a thrust device (18) suited to thrust said base material (6) towards said container (3).

6) Cartridge (2; 2'; 2'') according to any of the preceding claims, **characterized in that** it comprises detection means (10) suited to monitor the level of said base material (6) contained in said reservoir (5).

7) Cartridge (2; 2'; 2'') according to claim 6, **characterized in that** said detection means (10) are configured so as to emit an electrical signal that represents the level of said base material (6) contained in said reservoir (5), connection means (11) being provided which are suited to allow the transmission of said electrical signal to a device external to said cartridge (2; 2'; 2'').

8) Cartridge (2; 2'; 2'') according to any of the preceding claims,

characterized in that it comprises a door (12) movably associated with said access opening (4) in such a way as to assume at least one open position and at least one closed position for said access opening (4).

5 9) Cartridge (2; 2'; 2'') according to claim 8, **characterized in that** said door (12) is motorized so as to spontaneously assume said closed position.

10) Cartridge (2; 2'; 2'') according to any of the preceding claims, **characterized in that** said reservoir (5) contains said base material (6).

11) Cartridge (2; 2'; 2'') according to claim 10, **characterized in that** said reservoir (5) has a volume included between 1 cm³ and 50 cm³.

10 12) Cartridge (2; 2'; 2'') according to any of claims 10 or 11, **characterized in that** said transparent bottom (9) is configured in such a way that the energy, in the form of said predefined radiation (7), that is necessary to opacify it does not exceed 110% of the energy, in the form of said predefined radiation (7), that is necessary to solidify a volume of base material (6) equal to
15 the volume of said reservoir (5).

13) Cartridge (2; 2'; 2'') according to any of the preceding claims, **characterized in that** said predefined radiation (7) is suited to be emitted by emitting means (13) belonging to said stereolithography machine (1).

14) Method for manufacturing a cartridge (2; 2'; 2'') according to any
20 of the preceding claims, **characterized in that** it comprises the following operations:

- filling said reservoir (5) with said base material (6);
- sealing said reservoir (5) and said container (3).

15) Stereolithography machine (1) comprising:
25 - radiation emitting means (13) suited to emit a predefined radiation (7);
- a modelling platform (14) associated with power means suited to move said platform (14) along a movement trajectory (X),

characterized in that it comprises a cartridge (2; 2'; 2'') according to any of the claims from 1 to 13 and removable connection means (15) configured so
30 as to house said cartridge (2; 2'; 2'') in an operating position such that said transparent bottom (9) is arranged along the trajectory of said predefined radiation (7) and that said access opening (4) is arranged along said movement trajectory (X) of said modelling platform (14).

16) Stereolithography machine (1) according to claim 15, **characterized**
35 **in that** it comprises control means suited to be connected to said feeding

means (8) in order to operate them in such a way as to control the outflow of said base material (6) towards said container (3).

5

10

15

20

25

30

35

1/2

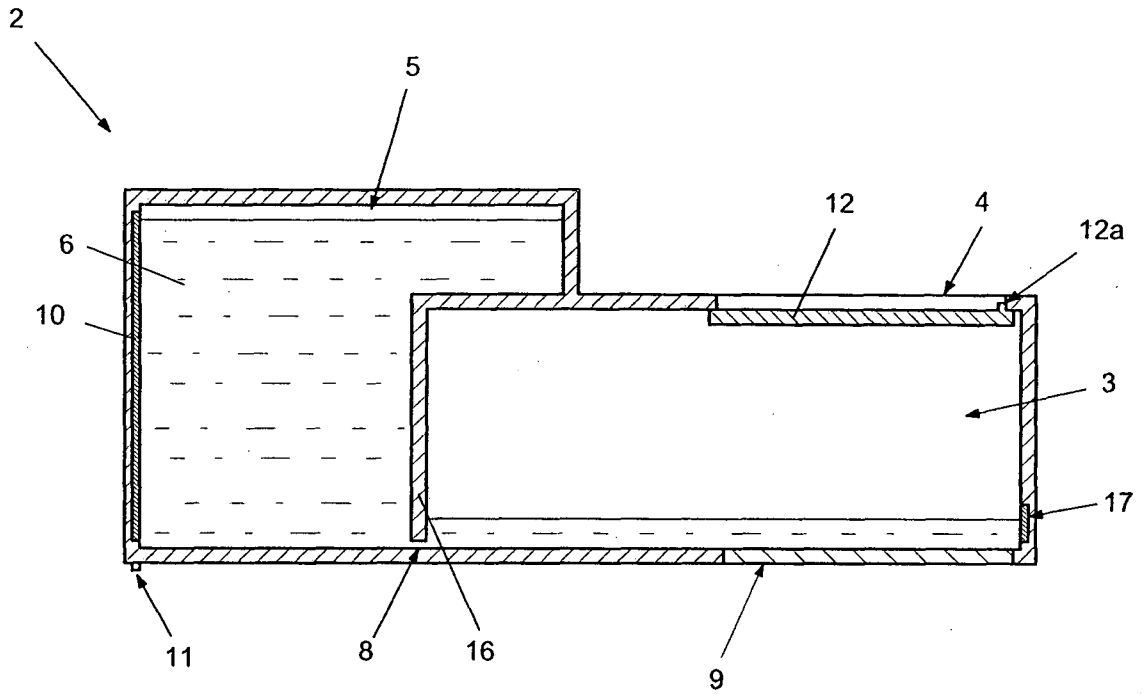

FIG. 1

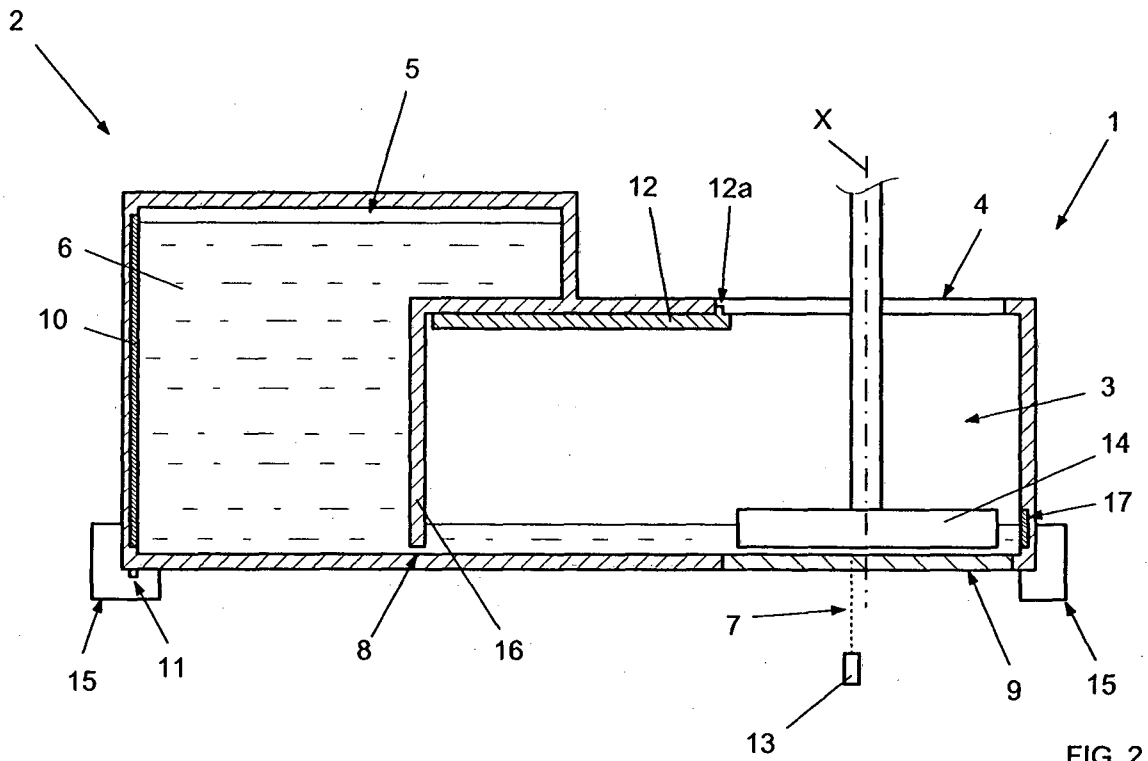

FIG. 2

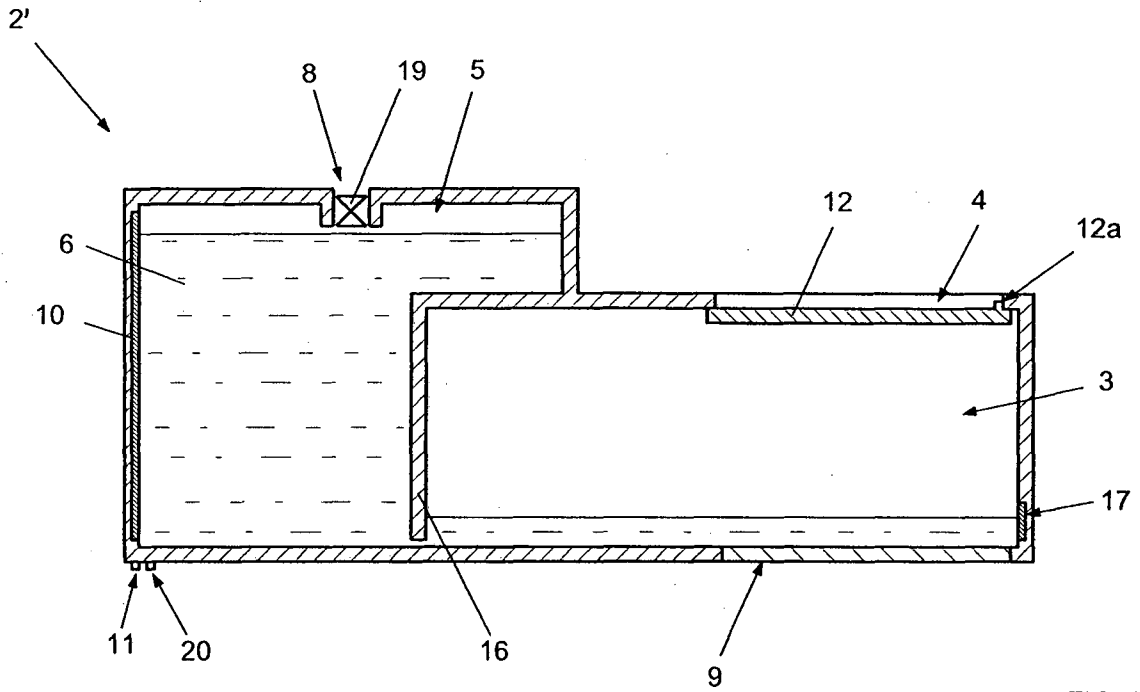

FIG. 3

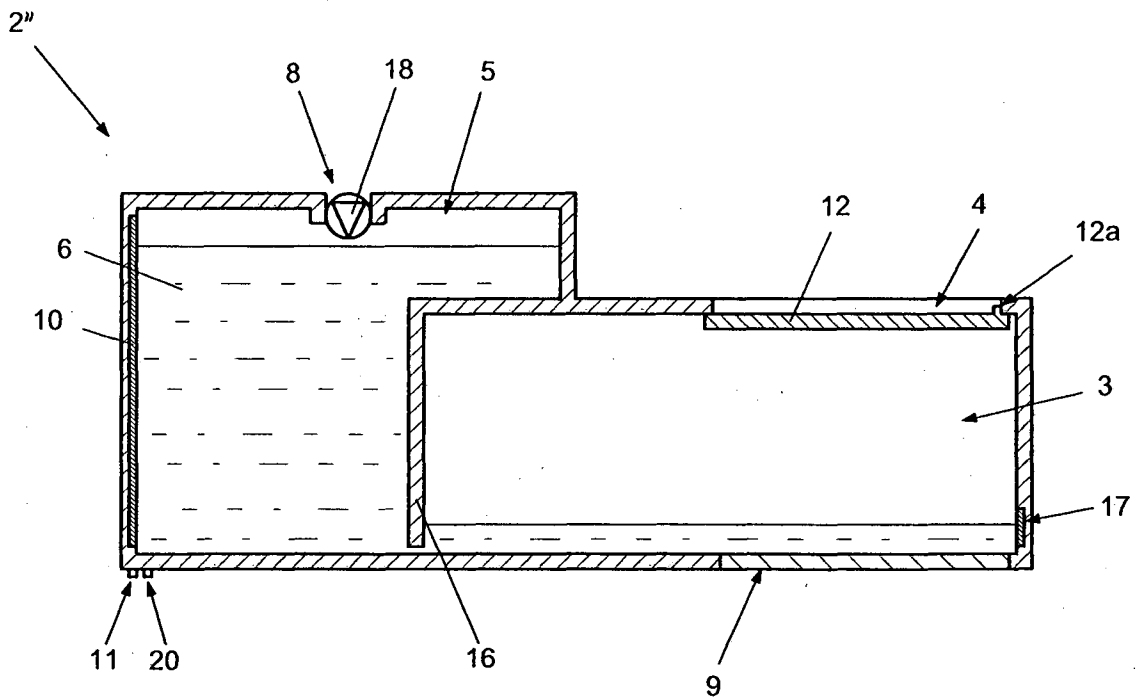

FIG. 4

INTERNATIONAL SEARCH REPORT

International application No
PCT/IB2013/001621

A. CLASSIFICATION OF SUBJECT MATTER
INV. B29C67/00
ADD.
According to International Patent Classification (IPC) or to both national classification and IPC

B. FIELDS SEARCHED
Minimum documentation searched (classification system followed by classification symbols)
B29C

Documentation searched other than minimum documentation to the extent that such documents are included in the fields searched

Electronic data base consulted during the international search (name of data base and, where practicable, search terms used)
EPO-Internal, WPI Data

C. DOCUMENTS CONSIDERED TO BE RELEVANT

Category*	Citation of document, with indication, where appropriate, of the relevant passages	Relevant to claim No.
A	EP 1 852 244 A2 (3D SYSTEMS INC [US]) 7 November 2007 (2007-11-07) figures 5, 6	1-16
A	----- JP H02 15333 U (UNKNOWN) 31 January 1990 (1990-01-31) figure 1	1-16
A	----- WO 2004/044816 A1 (OBJET GEOMETRIES LTD [IL]; MENCHIK GUY [IL]; GOTHAIT HANAN [IL]; KRITC) 27 May 2004 (2004-05-27) figure 2	1-16
A	----- EP 2 463 081 A1 (3M INNOVATIVE PROPERTIES CO [US]) 13 June 2012 (2012-06-13) figure 8	1-16

Further documents are listed in the continuation of Box C.

See patent family annex.

* Special categories of cited documents :

- "A" document defining the general state of the art which is not considered to be of particular relevance
- "E" earlier application or patent but published on or after the international filing date
- "L" document which may throw doubts on priority claim(s) or which is cited to establish the publication date of another citation or other special reason (as specified)
- "O" document referring to an oral disclosure, use, exhibition or other means
- "P" document published prior to the international filing date but later than the priority date claimed

"T" later document published after the international filing date or priority date and not in conflict with the application but cited to understand the principle or theory underlying the invention

"X" document of particular relevance; the claimed invention cannot be considered novel or cannot be considered to involve an inventive step when the document is taken alone

"Y" document of particular relevance; the claimed invention cannot be considered to involve an inventive step when the document is combined with one or more other such documents, such combination being obvious to a person skilled in the art

"&" document member of the same patent family

Date of the actual completion of the international search

16 December 2013

Date of mailing of the international search report

02/01/2014

Name and mailing address of the ISA/

European Patent Office, P.B. 5818 Patentlaan 2
NL - 2280 HV Rijswijk
Tel. (+31-70) 340-2040,
Fax: (+31-70) 340-3016

Authorized officer

Gasner, Benoit

INTERNATIONAL SEARCH REPORT

Information on patent family members

International application No

PCT/IB2013/001621

Patent document cited in search report	Publication date	Patent family member(s)	Publication date
EP 1852244	A2	07-11-2007	CN 101067721 A
			EP 1852244 A2
			JP 4855998 B2
			JP 2007296854 A
			US 2007257055 A1

JP H0215333	U	31-01-1990	NONE

WO 2004044816	A1	27-05-2004	AT 393009 T
			AU 2003279508 A1
			DE 60320588 T2
			EP 1581902 A1
			EP 1938952 A2
			EP 2298539 A1
			HK 1156280 A1
			US 2006127153 A1
			US 2010208016 A1
			US 2011289791 A1
			WO 2004044816 A1

EP 2463081	A1	13-06-2012	EP 2463081 A1
			EP 2648888 A1
			US 2013241095 A1
			WO 2012078533 A1
