

(No Model.)

F. SCHALCKE.
CAR COUPLING.

No. 527,725.

Patented Oct. 16, 1894.

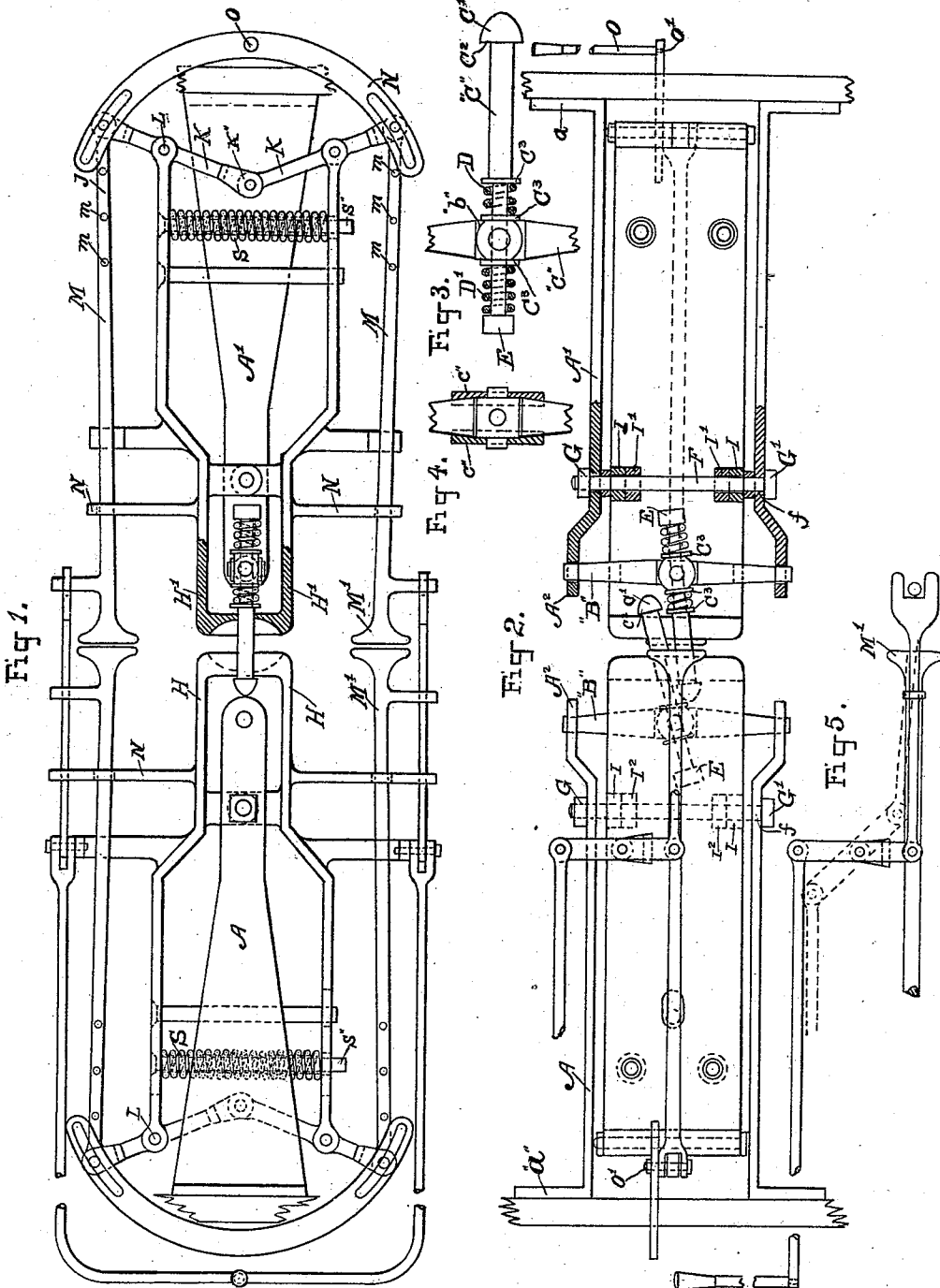

WITNESSES:

W. S. Jarboz
William J. Brown.

INVENTOR

Franz Schalcke
BY
Ewert & Appleman
ATTORNEYS,

UNITED STATES PATENT OFFICE.

FRANZ SCHALCKE, OF PITTSBURG, PENNSYLVANIA.

CAR-COUPLING.

SPECIFICATION forming part of Letters Patent No. 527,725, dated October 16, 1894.

Application filed February 7, 1894. Serial No. 499,336. (No model.)

To all whom it may concern:

Be it known that I, FRANZ SCHALCKE, a citizen of the United States of America, residing at Pittsburg, in the county of Allegheny and State of Pennsylvania, have invented certain new and useful Improvements in Car-Couplers, of which the following is a specification, reference being had to the accompanying drawings.

This invention relates to certain new and useful improvements in car couplings and more particularly to that class known as automatic couplers.

The invention contemplates to provide suitable and simple means whereby the cars of a train may be automatically coupled when the draw heads are brought together and uncoupled when desired or in case of a collision; furthermore, to employ a lever in connection with the device that will uncouple the front car from the engine.

The invention has for its further object to construct a device of the above referred to class that will have advantages in points of simplicity, durability and cheapness of manufacture.

With the above and other objects in view the invention finally consists in the novel construction, combination and arrangement of parts to be hereinafter more fully described and particularly pointed out in the claim.

In describing the invention in detail reference is had to the accompanying drawings forming a part of this specification and wherein like letters of reference indicate similar parts throughout the several views, in which—

Figure 1, is a plan view partly in section of my improved car coupler. Fig. 2, is a side elevation partly of the coupler. Fig. 3, is a detail view of the coupling pin and its leveraging. Fig. 4, is a detail transverse sectional view of Fig. 3. Fig. 5, is a detail view of the releasing mechanism.

In the drawings, A and A' represent two horizontal plates rigidly attached at "a" at the center on the end of each car. Said plates are provided at their free ends with apertured lugs A² A² adapted to receive the vertical shaft "B" having a transverse slot "b" which forms a movable bearing for the cone shaped

coupling pin "C" said pin being journaled in its bearing by outwardly extending lugs "c c" through the sides of the vertical shaft "B." The coupling pin C is provided with a cone shaped head "C'" which forms a shoulder C² at the forward end of the pin, said pin being provided with washers C³ C³ on each side of the bearing. Coil springs D and D' are arranged between the washers C³ C³ and nut E of the pin C. The plates A and A' are also connected by a vertical bolt "F" passing through the apertures "f" of the plates A and A' and held intact on the face of the plate A by means of a bolt G and to the plate A' on its underneath side by bolt "G'".

The drawhead provides a casing for the interior mechanism and is constructed in the shape of tongs H and H' at its forward end. Said tongs clasp the coupling pin "C" and the jaws are provided with a beveled face so as to receive the cone shaped head of the coupling pin of the opposite car. The sections of drawheads are made to extend parallel to each other where they are joined together at the top and bottom by inwardly extending apertured lugs I I and I' I' embracing the vertical bolt F which forms a fulcrum for the two sections of the drawhead. From this point rearwardly the sections extend outwardly as shown at J having their rear ends formed to provide a bearing of the arms K K pivotally attached at k in the center of the device fulcrumed at L L and carrying on their free ends horizontal bars "M M" pivoted to the arms K K. The bars M M extend forwardly and are slidingly mounted in bearings N N rigidly attached and extending outwardly at right angles of the drawheads H and H'. The said bars M M carry on their forward extremity buffers M' M', and on their other extremities a series of apertures "m m m;" the rearward end of the bars M M being connected under the platform of the car by means of a connecting piece N', pivotally attached to said bars. To the center of said connecting piece N', is secured pivotally the lever O which may extend to the platform of the car or to the top thereof and fulcrumed at O', in any suitable manner.

When the train is moving around sharp curves the apertures will conform to such a

condition as the same is adapted to slightly turn in either direction laterally on the vertical bolt.

5 The sections H and H' are connected and held together by means of coil springs S S attached interiorly to the sections H and H', said springs passing around bolts s, s, the heads of the latter being rigidly secured with their free ends operating in apertures.

10 Operation: When it is desired to couple a number of cars together they are brought in contact with one another thus forcing the cone shaped heads of the coupling pins between the jaws of the opposite coupler. The latter being beveled will force the same apart

15 and compress the springs "S S." When the shoulder of the cone shaped head is passed the springs S S will again retract to their normal position and the cone shaped heads will

20 be securely wedged between the jaws of the opposite coupler as will be readily understood. The cone shaped heads come to a point thus allowing the one to pass the other the coupling pin being movably mounted in its bearings and held in position by the coil springs.

25 When it is desired to uncouple the cars the levers P P are operated opening the jaws and allowing the cone shaped heads of the pin to disengage. The buffers of the horizontal

30 bars are so arranged as to come within a short distance of the corresponding buffers on the opposite coupler in order, that in case of an accident the concussion caused by the car will cause the opposite buffers to come in contact with one another, thus forcing the arms

35 to operate and the springs S S to contract

thereby opening the jaws and simultaneously releasing the cone shaped heads from engagement.

It will be seen that by employing the above described coupler only the engine could be demolished in case of a collision between trains the cars being uncoupled automatically as heretofore described.

Attention is called to the fact that my improved coupler may also be employed on railroad trains provided with the airbrake system it being a well known fact that the latter may also be uncoupled automatically when the cars are drawn apart a certain distance.

Although the coupler as above described will successfully operate, yet I do not wish to limit myself to this specific construction as various changes may be made in the details without departing from the general idea involved in this invention.

Having fully described my invention, what I claim as new, and desire to secure by Letters Patent, is—

In a car coupler, a cone shaped coupling pin journaled in its bearings by outwardly extending lugs, in combination with a drawhead made in parallel sections in shape of tongs, and buffers to automatically operate the drawhead for the purpose described.

In testimony whereof I affix my signature in presence of two witnesses.

FRANZ SCHALCKE.

Witnesses:

H. C. EVERT,
ROBERT T. MCELROY.