

(No Model.)

J. CRAWFORD.

WATER CLOSET.

No. 383,045.

Patented May 15, 1888.

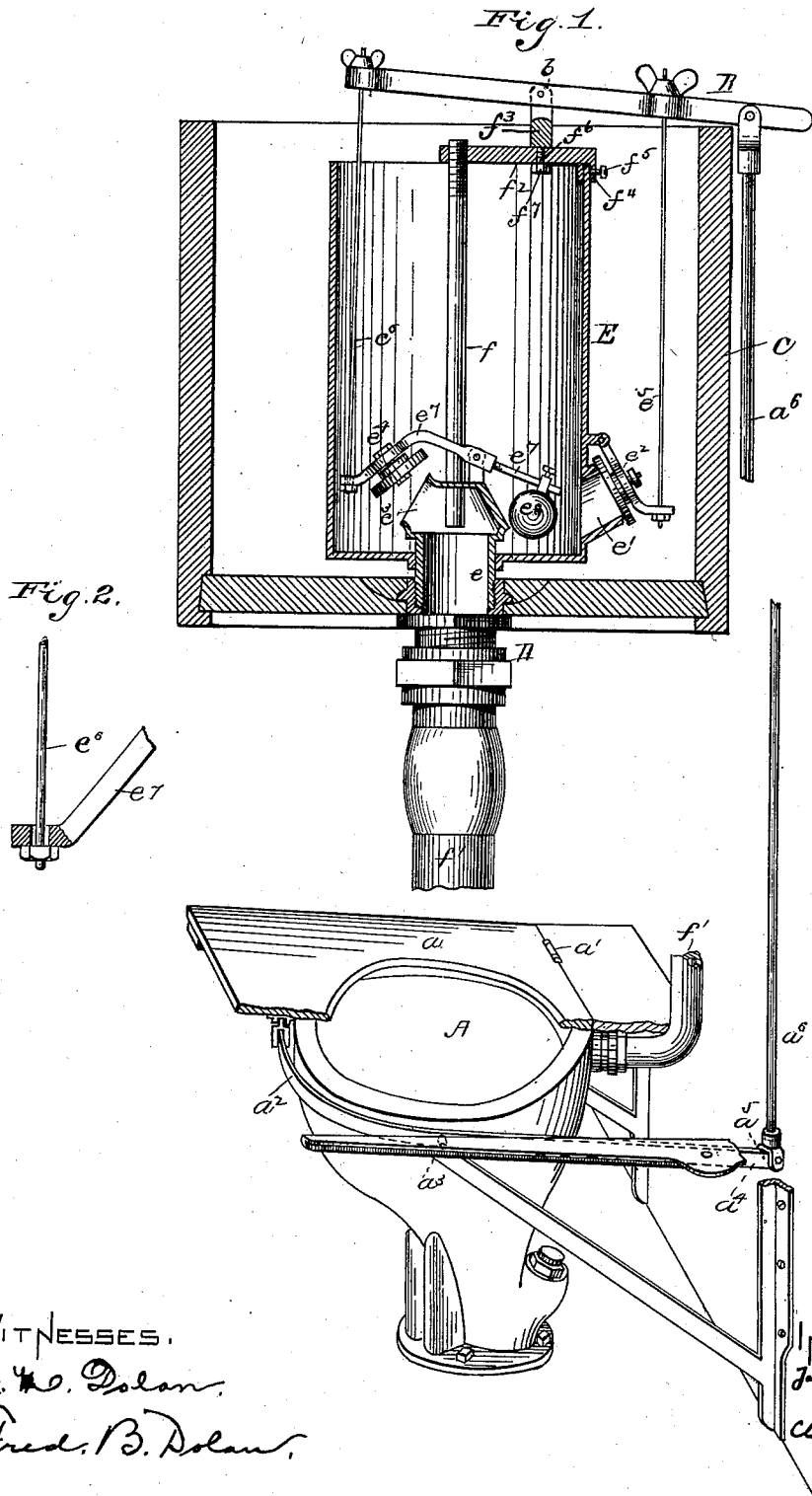

WITNESSES.

J. W. Dolan,
Fred. B. Dolan,

INVENTOR,
James Crawford,
by his attys.
Clarke & Raymond.

UNITED STATES PATENT OFFICE.

JAMES CRAWFORD, OF CAMBRIDGE, MASSACHUSETTS.

WATER-CLOSET.

SPECIFICATION forming part of Letters Patent No. 383,045, dated May 15, 1888.

Application filed February 25, 1887. Serial No. 238,853. (No model.)

To all whom it may concern:

Be it known that I, JAMES CRAWFORD, of Cambridge, in the county of Middlesex and State of Massachusetts, a citizen of the United States, have invented a new and useful Improvement in Water-Closets, of which the following is a full, clear, and exact description, reference being had to the accompanying drawings, forming a part of this specification, in explaining its nature.

The invention relates to the class of water-closets described in the joint application of Ernest W. Clark and myself for Letters Patent of the United States, executed of even date herewith, and is an improvement upon the apparatus therein described.

Referring to the drawings, Figure 1 is a view in perspective of the bowl and the seat and an enlarged vertical section of the tank and service-box connected therewith, showing their relation to each other and their connection or connections with the supply-pipe running to the bowl. Fig. 2 is a detail view to show the loose connection between the valve-lever and its operating-rod.

A is the bowl; *a*, the movable seat, hinged at *a'*, and which is connected at its front end with the lever *a²*. This lever is pivoted at *a³*, and its arm *a⁴* is connected at its rear end, *a⁵*, with the rod *a⁶*, which is connected at its upper end with the valve-lever B.

C is the tank. It is lined with metal, and has in its bottom the single coupling D, which is in every respect like that described in the said Clark and Crawford application.

E is the service-box. It preferably is made of metal by casting, although it may be formed from sheet metal. It has a screw-sleeve, *e*, and inlet-passage *e'*, adapted to be closed by the clapper-valve *e²*, and the outlet *e³*, adapted to be closed by the clapper-valve *e⁴*. The valve *e²* is connected by a rod, *e⁵*, with the lever B, and the clapper-valve *e⁴* by the rod *e⁶* with the lever B upon the opposite side of its fulcrum *b* from that to which the rod *e⁵* is secured. The valve *e⁴* has an arm, *e⁷*, carrying a float, *e⁸*.

The operation of this form of the invention is as follows: Upon the downward movement of the seat the lever B is moved upward. This releases the valve *e⁴*, so far as the holding bar or chain *e⁸* is concerned, and permits it to be operated entirely by the float *e⁸*. This move-

ment of the lever also opens the clapper-valve *e²* and permits water to flow from the tank into the service-box, and the water first admitted in this way escapes through the passage *e³* until it has risen in the box sufficiently to cause the valve *e⁴* to be closed by the upward movement of the float. The valve *e²*, however, continues open, so that the water flows into and fills the service-box after the closing of the valve *e⁴*. It is intended that this valve *e⁴* shall remain open long enough to permit the escape of a sufficient quantity of water from the box for the preliminary washing of the bowl, and that it shall then close. Upon the releasing of the seat the valve *e²* is permitted to close and the valve *e⁴* lifted by the movement of the lever B, so that the water, which then substantially fills the service-box, is allowed to escape in a full flushing-stream to the bowl. It will be seen that this construction is less complicated and less expensive than that described in the application above referred to and answers the purpose equally well; also, that the same results are secured by the employment of a service-box having a single section, and by two valves instead of three.

The pipe *f*, which admits air to the conducting-pipe *f'*, serves as a support for the inner end of the cross-bar *f²*, which carries the standard *f³*, to which the lever B is pivoted, the outer end of the said cross-bar preferably having a grooved lip, *f⁴*, engaging the upper edge of the cylindrical service-box E, to which the said cross-bar may be secured (to retain it in place) by a set-screw, *f⁵*. The cross-bar *f²* may be turned on the pipe *f* as a center to adjust the lever B to any desired position in setting up the parts for operation; but to permit of such adjustment of the said lever and of the cross-bar it is necessary that the standard *f³* should be attached to the said bar by a vertical pivot, *f⁶*, which will permit the said standard to be turned, as may be desired, to accommodate it to different positions of the lever B. At the lower end of the pivot *f⁶* is a set-nut, *f⁷*, for securing the standard in any position to which it may be adjusted.

I have shown the outlet of the service-box as inclined. This is for the purpose of permitting water to flow from the box until it reaches the level of the lower edge of the outlet, so that the float falls, and upon the filling

of the box must begin to operate from that level. This permits a sufficient quantity of water to flow through the outlet upon the admission of the water to the box, which flow is
5 at first quite free, and is then gradually stopped as the water flows into the box and lifts the float, the valve gradually closing as the water lifts, so that the area of the escape-passage is being gradually decreased until the valve
10 finally is closed. Water, however, still continues to flow in through the inlet until the water in the box reaches the level of the water in the tank.

Having thus fully described my invention, I
15 claim and desire to secure by Letters Patent of the United States—

In a water-closet, the combination, with a movable seat and a lever, B, connected there-

with, of a tank, a service box having a single escape-passage, e^3 , and an inlet, e' , from said tank, a valve, e^2 , for said inlet connected with said lever, said valve to be opened when the seat is depressed, a valve, e^4 , for the said escape-passage, a lever, e^7 , by which the said valve e^4 is carried, a float on the end of the
25 said lever e^7 opposite to the said valve e^4 , and a rod, e^6 , connecting the valve end of the lever e^7 with the said lever B, whereby the escape-valve will be closed by the float as the service-box is filled and opened by the lever B when
30 the seat is raised, substantially as set forth.

JAMES CRAWFORD.

In presence of—

F. F. RAYMOND, 2d,
J. M. DOLAN.