

J. B. CHRISTIAN.
Improvement in Well-Augers.

No. 131,427.

Patented Sep. 17, 1872.

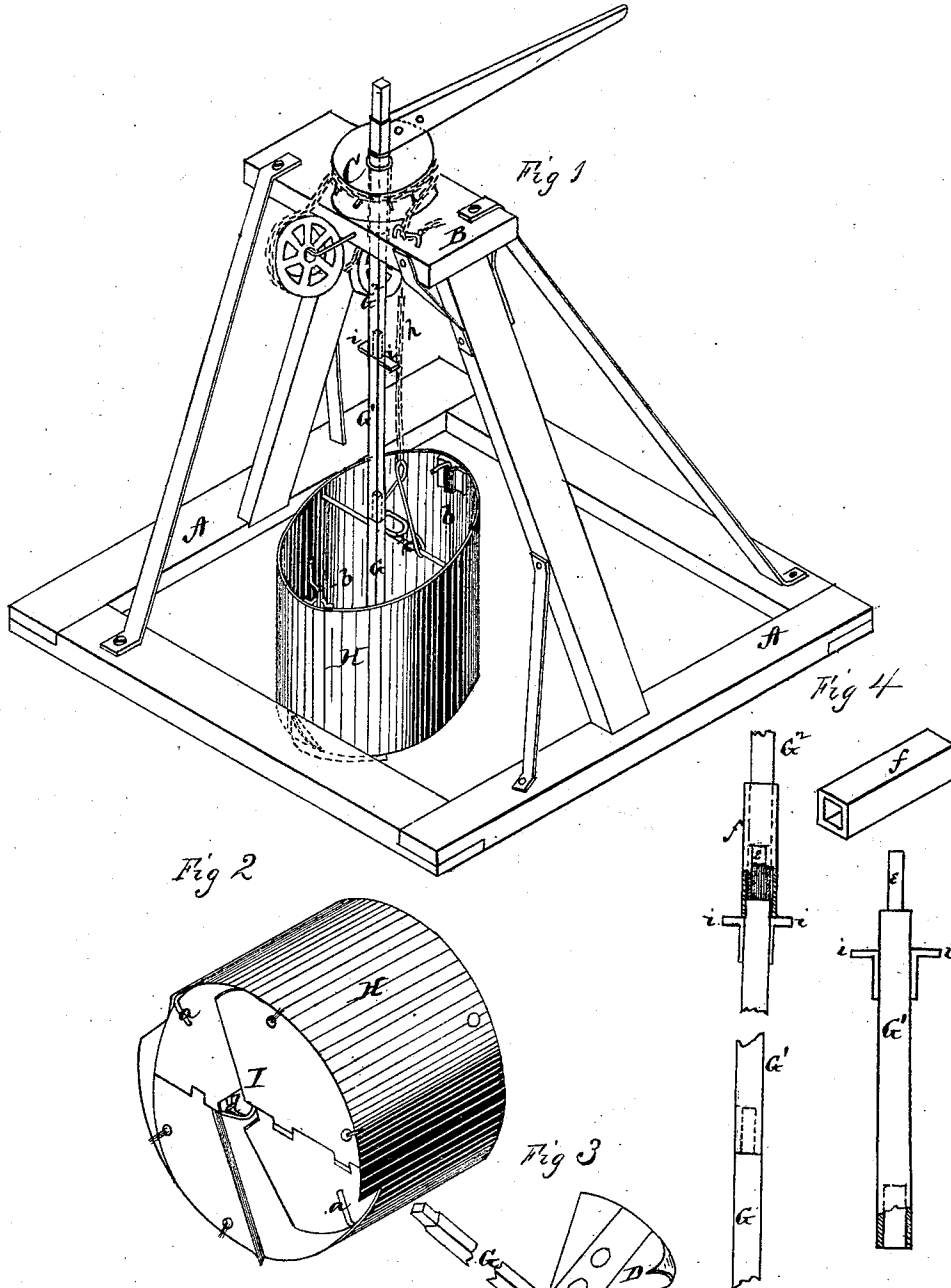

Witnesses:
Francis L. Curand
C. L. Ewert.

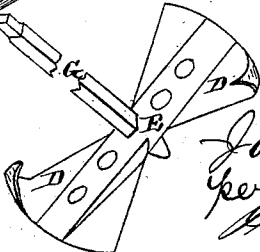

Inventor.
John B. Christian
per
Alexander Mann

Attorneys.

UNITED STATES PATENT OFFICE.

JOHN B. CHRISTIAN, OF HAMBURG, IOWA.

IMPROVEMENT IN WELL-AUGERS.

Specification forming part of Letters Patent No. 131,427, dated September 17, 1872.

To all whom it may concern:

Be it known that I, JOHN B. CHRISTIAN, of Hamburg, in the county of Fremont and in the State of Iowa, have invented certain new and useful Improvements in Well-Augers; and do hereby declare that the following is a full, clear, and exact description thereof, reference being had to the accompanying drawing and to the letters of reference marked thereon making a part of this specification.

The nature of my invention consists in the construction and arrangement of the auger, bucket, and shaft of a well-boring machine, as will be hereinafter more fully set forth.

In order to enable others skilled in the art to which my invention appertains to make and use the same, I will now proceed to describe its construction and operation, referring to the annexed drawing, in which—

Figure 1 is a perspective view of a well-boring machine having my auger, bucket, and shaft. Fig. 2 is a perspective view of the bucket. Fig. 3 is a similar view of the auger; and Fig. 4 represents the shaft.

A represents the ground-frame, with a bed-piece, B, elevated above, and suitably braced to said frame. On this bed-piece is arranged the horse-power C, for operating my well-auger, and to raise the bucket. The auger consists of two bits, D D, bolted to a piece, E, of wrought-iron, which piece is beveled on the sides that the bits cut. In the center of this wrought-iron piece E is secured a shaft, G, the end of which projects below to form the center-point of the auger. The bucket H is made of heavy sheet-iron, with a bottom, I, placed in the same, said bottom being made in separate pieces, as shown in Fig. 2, hung on hinges, so as to form two halves. One section of each half is hinged to the side of the bucket, while the other section is supported by a hook, a, formed on the lower end of a vertical rod, b, which passes through suitable eyes or loops on the inside of the bucket, and is provided with a suitable handle at its upper end for turning the same. The boring-shaft will be made square, about one and one-half inch thick, and in as many pieces as may be necessary to reach down the desired depth. In the bottom, or, rather, the lower end of the bucket H, is a bar, d, with square hole, to allow the shafting to

pass through, and the bucket to slide up and down on the same. When the bucket is down the lips in the bottom of the bucket will rest on the auger-bits D D, and the bottom will settle behind the bar E, to which the bits are secured. The various parts of the shaft are connected by smooth couplings, a socket being formed in one end of one piece, and a corresponding square tenon on the next piece. The bucket being heavy and placed, in proper manner, on the shaft, it cannot help coming down the shaft in its proper place, no matter how deep the well. When the auger is in motion the lips in the bottom of the bucket will rise, and allow the dirt to pass around on the bottom of the bucket. When the bucket is loaded, I raise a sleeve or coupling, f, connecting the two upper sections G¹ and G² of the shafting, which sleeve or coupling should be fastened by a set-screw. Under this square coupling is a round coupling, e, as shown in Fig. 4. When the coupling f is raised from off the round coupling e the lever on the horse-power is lowered, so as to turn the capstan, and the horse being started the top shaft G² will revolve on the round coupling. The capstan will draw the chain h, which is attached to a cross-bar, k, in the upper end of the bucket, and thus draw the bucket up the shaft till it strikes projections i i on the section G¹, which should be just the length of the bucket. This section will then uncouple at the bottom of the bucket. The upper section G² is then slipped off the round coupling, leaving the section G¹ in the bucket. The bucket is then carried away by a derrick, and emptied by letting the bottom drop out. It is then swung back, the section G¹ coupled at the bottom and the top, and the sleeve or coupling f lowered over the round coupling, when the bucket is lowered down on the shaft again. The auger cuts a hole a little larger than the buckets, the auger-bits being placed out at the bottom and the lips turned in, which draws the dirt into the bucket and gives plenty of air, so that the bucket is drawn up very easy.

I do not claim the horse-power C, arranged on the bed-piece B of the frame of the machine, for operating the well-auger and raising the bucket.

Having thus fully described my invention,

what I claim as new, and desire to secure by Letters Patent, is—

1. The shaft for well-augers herein described, having the sections G G^1 G^2 , projections i i , round coupling e , and square coupling f , substantially as and for the purposes herein set forth.

2. The combination of the sectional shaft G G^1 G^2 and its projections i i and couplings e f with the auger-bits D and bar E , and bucket

H with bottom I , all substantially as and for the purposes herein set forth.

In testimony that I claim the foregoing I have hereunto set my hand this 15th day of April, 1872.

JOHN B. CHRISTIAN.

Witnesses:

J. W. DALBEY,
C. L. EVERT.