



(19) **United States**
 (12) **Reissued Patent**
Graf et al.

(10) **Patent Number:** **US RE50,060 E**
 (45) **Date of Reissued Patent:** **Jul. 30, 2024**

(54) **TOPICAL ADMINISTRATION METHOD**
 (71) Applicant: **NOVALIQ GMBH**, Heidelberg (DE)
 (72) Inventors: **Gesche Graf**, Bensheim (DE); **Yasin Ahmed**, Upminster (GB); **Stephanie Legner**, Stuttgart (DE); **Philip Kemp**, Thatcham (GB)
 (73) Assignee: **Novaliq GmbH**, Heidelberg (DE)
 (21) Appl. No.: **17/899,610**
 (22) Filed: **Aug. 31, 2022**

Related U.S. Patent Documents

Reissue of:
 (64) Patent No.: **10,507,132**
 Issued: **Dec. 17, 2019**
 Appl. No.: **16/312,855**
 PCT Filed: **Jun. 21, 2017**
 PCT No.: **PCT/EP2017/065163**
 § 371 (c)(1),
 (2) Date: **Dec. 21, 2018**
 PCT Pub. No.: **WO2017/220625**
 PCT Pub. Date: **Dec. 28, 2017**

Foreign Application Priority Data

Jun. 23, 2016 (EP) 16176074
 Jul. 19, 2016 (EP) 16180202
 May 6, 2017 (EP) 17169837

(51) **Int. Cl.**
A61F 9/00 (2006.01)
A61K 9/00 (2006.01)
 (Continued)
 (52) **U.S. Cl.**
 CPC **A61F 9/0008** (2013.01); **A61F 9/0026** (2013.01); **A61K 9/0048** (2013.01);
 (Continued)

(58) **Field of Classification Search**
 CPC A61F 9/0008; A61F 9/0026; A61F 2230/0067; A61F 2230/0023;
 (Continued)

(56) **References Cited**
U.S. PATENT DOCUMENTS

2,616,927 A 11/1952 Kauck et al.
 5,077,036 A 12/1991 Long, Jr.
 (Continued)

FOREIGN PATENT DOCUMENTS

EP 0 089 815 9/1983
 EP 0593552 4/1994
 (Continued)

OTHER PUBLICATIONS

Bardin et al., "Long-Range Nanometer-Scale Organization of Semifluorinated Alkane Monolayers at the Air/Water Interface," *Langmuir*, 2011, 27:13497-13505.
 (Continued)

Primary Examiner — Catherine S Williams
 (74) *Attorney, Agent, or Firm* — Hoxie and Associates LLC

(57) **ABSTRACT**

The present invention relates to a method for topical administration of ophthalmic compositions in a dropwise manner, preferably for topical administration of ophthalmic compositions comprising semifluorinated alkanes (SFAs). Further, the present invention relates to the use of said methods in the prevention or treatment of ocular diseases or disorders or any symptoms or conditions associated therewith. In a further aspect, the present invention relates to a kit comprising a drop dispenser at least partially filled with a liquid composition for the use in such a method and directions for use of said drop dispenser.

49 Claims, 6 Drawing Sheets

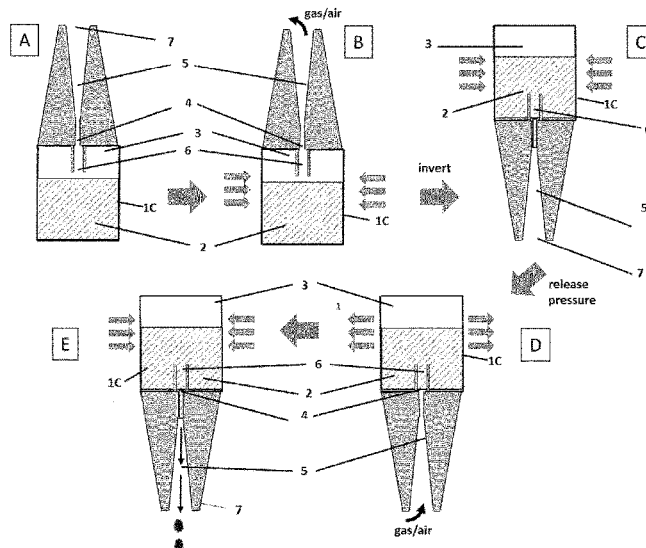

US RE50,060 E

(51)	Int. Cl.			11,324,757	B2	5/2022	Theisinger et al.	
	A61K 31/02	(2006.01)		11,413,323	B2	8/2022	Leo et al.	
	A61P 27/02	(2006.01)		2002/0004063	A1	1/2002	Zhang	
	A61P 27/04	(2006.01)		2002/0128527	A1	9/2002	Meinert	
(52)	U.S. Cl.			2003/0018044	A1	1/2003	Peyman	
	CPC	A61K 31/02 (2013.01); A61P 27/02		2003/0027833	A1	2/2003	Cleary et al.	
		(2018.01); A61P 27/04 (2018.01); A61F		2003/0170194	A1	11/2003	Piotrowiak	
		2230/0023 (2013.01); A61F 2230/0067		2004/0044045	A1	3/2004	Burk	
		(2013.01)		2004/0082660	A1	4/2004	Ueno	
(58)	Field of Classification Search			2004/0265362	A1	12/2004	Susilo	
	CPC	A61K 9/0048; A61K 31/02; A61P 27/04;		2004/0266702	A1	12/2004	Dawson	
		A61P 27/02		2005/0079210	A1	4/2005	Gupta	
	See application file for complete search history.			2005/0175541	A1	8/2005	Lanza et al.	
				2005/0274744	A1*	12/2005	Spada	A61F 9/0026 222/240
(56)	References Cited			2005/0288196	A1	12/2005	Horn	
	U.S. PATENT DOCUMENTS			2006/0153905	A1	7/2006	Carrara et al.	
	5,370,313 A	1/1994	Beard	2008/0039807	A1*	2/2008	Pine	A61F 9/0008 604/300
	5,326,566 A	7/1994	Parab	2008/0050335	A1	2/2008	Faour et al.	
	5,336,175 A	8/1994	Mames	2008/0153909	A1	6/2008	Dana et al.	
	5,518,731 A	5/1996	Meadows	2008/0207537	A1	8/2008	Turner et al.	
	5,578,020 A *	11/1996	Mosley	2008/0234389	A1	9/2008	Mecozzi et al.	
			A61F 9/0026 604/300	2008/0260656	A1	10/2008	Mallard	
				2009/0149546	A1	6/2009	Chang	
				2010/0006600	A1*	1/2010	Dascanio	A61M 11/08 222/71
				2010/0008996	A1	1/2010	Meinert	
	5,667,809 A	9/1997	Trevino	2010/0016814	A1*	1/2010	Gokhale	A61F 9/0008 604/298
	5,874,469 A	2/1999	Maniar et al.	2010/0226997	A1	9/2010	Bowman et al.	
	5,874,481 A	2/1999	Weers	2010/0274215	A1	10/2010	Wong et al.	
	5,980,936 A	11/1999	Krafft et al.	2011/0269704	A1	11/2011	Seigfried	
	5,981,607 A	11/1999	Ding	2012/0010280	A1	1/2012	Aleo et al.	
	6,042,845 A	3/2000	Sun et al.	2012/0095097	A1	4/2012	Tabuchi et al.	
	6,060,085 A	5/2000	Osborne	2012/0238639	A1	9/2012	Theisinger et al.	
	6,113,919 A	9/2000	Cronelus	2013/0046014	A1	2/2013	Theisinger et al.	
	6,159,977 A	12/2000	Reeves	2013/0084250	A1	4/2013	Hagedorn et al.	
	6,177,477 B1	1/2001	George et al.	2013/0266652	A1	10/2013	Theisinger et al.	
	6,197,323 B1	3/2001	Georgieff	2013/0303473	A1	11/2013	Wilson	
	6,224,887 B1	5/2001	Samour et al.	2014/0004197	A1	1/2014	Theisinger et al.	
	6,262,126 B1	7/2001	Meinert	2014/0100180	A1	4/2014	Günther et al.	
	6,294,563 B1	9/2001	Garst	2014/0140942	A1	5/2014	Günther et al.	
	6,372,243 B2	4/2002	Kobuch et al.	2014/0369993	A1	12/2014	Günther et al.	
	6,391,879 B1	5/2002	Reeves	2015/0224064	A1	8/2015	Günther et al.	
	6,458,376 B1	10/2002	Meadows	2015/0238605	A1	8/2015	Günther et al.	
	6,486,212 B2	11/2002	Meinert	2016/0159902	A1	6/2016	Günther et al.	
	6,489,367 B1	12/2002	Meinert	2017/0020726	A1*	1/2017	Labombarbe	B65D 1/08
	6,730,328 B2	5/2004	Maskiewicz et al.	2017/0087100	A1	3/2017	Scherer et al.	
	7,001,607 B1	2/2006	Menz	2017/0087101	A1	3/2017	Scherer et al.	
	7,026,359 B1	4/2006	Gross	2017/0182060	A1	6/2017	Wiedersberg et al.	
	7,258,869 B1	8/2007	Berry	2018/0360908	A1	12/2018	Beier et al.	
	7,740,875 B2	6/2010	Dechow	2019/0274970	A1	9/2019	Günther et al.	
	8,029,977 B2	10/2011	Meinert et al.	2019/0328717	A1	10/2019	Günther et al.	
	8,470,873 B2	6/2013	Chen	2019/0343793	A1	11/2019	Günther et al.	
	8,614,178 B2	12/2013	Theisinger et al.	2020/0268682	A1	8/2020	Günther et al.	
	8,796,340 B2	8/2014	Theisinger et al.	2021/0069014	A1	3/2021	Loscher et al.	
	8,916,157 B2	12/2014	Krause et al.	2021/0106558	A1	4/2021	Loscher et al.	
	8,986,738 B2	3/2015	Meinert	2021/0346313	A1	11/2021	Beier et al.	
	9,241,900 B2	1/2016	Wilson					
	9,308,262 B2	4/2016	Günther et al.					
	9,757,459 B2	9/2017	Theisinger et al.					
	9,757,460 B2	9/2017	Günther et al.					
	9,770,508 B2	9/2017	Günther et al.					
	9,968,678 B2	5/2018	Theisinger et al.					
	10,045,996 B2	8/2018	Theisinger et al.					
	10,058,615 B2	8/2018	Günther et al.					
	10,064,944 B2	9/2018	Wilson					
	10,130,707 B2	11/2018	Günther et al.					
	10,369,117 B2	8/2019	Günther et al.					
	10,449,164 B2	10/2019	Günther et al.					
	10,525,062 B2	1/2020	Theisinger et al.					
	10,555,953 B2	2/2020	Theisinger et al.					
	10,576,154 B2	3/2020	Günther et al.					
	10,682,315 B2	6/2020	Scherer et al.					
	10,813,976 B2	10/2020	Loscher et al.					
	10,813,999 B2	10/2020	Günther et al.					
	11,154,513 B2	10/2021	Scherer et al.					
	11,160,865 B2	11/2021	Theisinger et al.					
	11,273,174 B2	3/2022	Loscher et al.					
	11,278,503 B2	3/2022	Günther et al.					
				FOREIGN PATENT DOCUMENTS				
				EP	0 670 159	9/1995		
				EP	0 965 329	12/1999		
				EP	0 965 334	12/1999		
				EP	1 152 749	11/2001		
				EP	0 939 655	6/2002		
				EP	2 110 126	10/2009		
				EP	2 332 525	6/2011		
				EP	2 335 735	6/2011		
				EP	2 462 921	6/2012		
				JP	S6452722	2/1989		
				JP	2000511157	8/2000		
				JP	2001/158734	6/2001		
				JP	2008/505177	2/2008		
				JP	2011/006348	1/2011		
				JP	2011-024841	2/2011		
				JP	2011-024841 A	2/2011		

(56) References Cited

FOREIGN PATENT DOCUMENTS

WO	WO 1995/033447	12/1995
WO	WO 96/40052	12/1996
WO	WO 97/12852 A1	4/1997
WO	WO 1998/005301	12/1998
WO	WO 00/10531	3/2000
WO	WO 00/024376	5/2000
WO	WO 00/054588	9/2000
WO	WO 02/49631 A1	6/2002
WO	WO 2004/043315	5/2004
WO	WO 2005/018530	3/2005
WO	WO 2005/099718	10/2005
WO	WO 2005/099752	10/2005
WO	WO 2005/123035	12/2005
WO	WO 2006/007510	1/2006
WO	WO 2006/042059	4/2006
WO	WO 2006/048242	5/2006
WO	WO 2007/052288	5/2007
WO	WO 2008/060359	5/2008
WO	WO 2009/013435	1/2009
WO	WO 2010/062394	6/2010
WO	WO 2010/146536	12/2010
WO	WO 2011/009436	1/2011
WO	WO 2011/113855	3/2011
WO	WO 2011/073134	6/2011
WO	WO 2012/052418	4/2012
WO	WO 2012/062834	5/2012
WO	WO 2012/093113	7/2012
WO	WO 2012/121754	9/2012
WO	WO 2012/160179	11/2012
WO	WO 2012/160180	11/2012
WO	WO 2013/110621	8/2013
WO	WO 2014/041055	3/2014
WO	WO 2014/041071	3/2014
WO	WO 2014/154531	10/2014
WO	WO 2015/011199	1/2015
WO	WO 2016/025560	2/2016
WO	WO 2016/025560 A1	2/2016
WO	WO 2018/115097	6/2018

OTHER PUBLICATIONS

Hardung, H., "Semifluorierte und perfluorierte Verbindungen zur topischen und parenteralen Anwendung," 2008, 188 pages, retrieved from Internet, date accessed: Oct. 10, 2011, URL: <http://www.freidok.uni-freiburg.de/volltexte/5682/pdf/Dissertation_Hardung.pdf>.

Lin, H. et al., "Dry eye disease: A review of diagnostic approaches and treatments," *Saudi Journal of Ophthalmology*, 2014, 28:173-181.

Meinert, H. et al., "The Use of Semifluorinated Alkanes in Blood-Substitutes," *Biomaterials, Artificial Cells, and Immobilization Biotechnology*, 1993, 21 (5), 583-595.

Meinert, H. et al., "Semifluorinated Alkanes—A New Class of Compounds with Outstanding Properties for Use in Ophthalmology," *European Journal of Ophthalmology*, 2000, 10(3), 189-197.

O'Rourke, M. et al., "Enhancing Delivery of Topical Ocular Drops," *Cataract & Refractive Surgery Today Europe*, 2016, 2 pages.

Wong et al., "Perfluorocarbons and Semifluorinated Alkanes," *Seminars in Ophthalmology*; vol. 15 (1), 2000, p. 25-35.

Xalatan, Latanoprost Ophthalmic Solution, 50 µg/mL Prostaglandin F_{2α} analogue, Product Monograph, Jul. 21, 2014, 30 pages.

Ahmed, et al., "Disposition of Timolol and Inulin in the Rabbit Eye Following Corneal Versus Non-Corneal Absorption," *International Journal of Pharmaceutics*, 1987, 38:9-21.

Baerdemaeker, "Pharmacokinetics in Obese Patients," *Continuing Education in Anesthesia, Critical Care & Pain*, 2004, 4:152-155.

Barata-Vallejo et al., "(Me₂Si)₂SiH-Mediated Intermolecular Radical Perfluoroalkylation Reactions of Olefins in Water," *J. Org. Chem.*, 2010, 75:6141-6148.

Blackie et al., "MGD: Getting to the Root Cause of Dry Eye", *Review of Optometry*, 2012, pp. 1-12.

Broniatowski, M. et al., "Langmuir Monolayers Characteristics of (Perfluorodecyl)-Alkanes," *Journal of Physical Chemistry B*, 2004, 108:13403-13411.

Chemical Book, "5-Fluorouracil," available at http://www.chemicalbook.com/-ChemicalProductProperty_EN_CB8162744.htm;>, accessed Mar. 7, 2014, 1 page.

Chhadva et al., "Meibomian Gland Disease the Role of Gland Dysfunction in Dry Eye Disease," *Ophthalmology* (2017) 124(11 Supplement): S20-S26.

Costa Gomes et al., "Solubility of dioxygen in seven fluorinated liquids," *Journal of Fluorine Chemistry*, 2004, 125:1325-1329.

Davies, "Biopharmaceutical Considerations in Topical Ocular Drug Delivery," *Clin. Exper. Pharmacol. Physiol.*, 2000, 27:558-562.

Dembinski et al., Semi-fluorinated Alkanes as Carriers for Drug Targeting in Acute Respiratory Failure, *Experimental Lung Research*, 2010, 36(8):499-507.

Dias et al., "Solubility of oxygen in liquid perfluorocarbon," *Fluid Phase Equilibria*, 2004, 222-223:325-630.

Elkeeb et al., "Transungual Drug Delivery: Current Status," *Int J Pharmaceutics*, 2010, 384:1-8.

English-language machine translation of EP0670159 (A1) issued in U.S. Appl. No. 14/122,025 on Apr. 1, 2015, 10 pages.

Freiburger Dokumentenserver (FreiDok), Albert-Ludwigs, Universität Feiburg im Breisgau, retrieved from the Internet, date accessed: Feb. 5, 2014, 2 pages URL: <<http://www.freidok.uni-freiburg.de/volltexte/5682>>.

Gayton, J., "Etiology, Prevalence, and Treatment of Dry Eye Disease," *Clinical Ophthalmology*, 2009,3:405-412.

Gehlsen et al., "A semifluorinated alkane (F4H5) as novel carrier for cyclosporine A: a promising therapeutic and prophylactic option for topical treatment of dry eye," *Graefe's Arch. Clin. Exp. Ophthalmol.*, (2017) 255(4):767-775.

Gehlsen, U., et al., "Cyclosporine A using F4H5 as liquid drug carrier is effective in treating experimental dry-eye disease," *Investigative Ophthalmology & Visual Science*, 2015, 56(319), Abstract Only (2 pages).

Gerdentisch, "Emulsions—established and promising drug carriers for parenteral administration", retrieved from Internet, date accessed: Jun. 20, 2016, 2 pages URL: <<http://ipimediaworld.com/wp-content/uploads/2012/05/Pages-from-IPI-Volume-2-Issue-1-11.pdf>>.

German, E.J., et al., "Reality of drop size from multi-dose eye drop bottles: is it cause for concern?" *Eye*, 1999, 13:93-100.

Gopal et al., "Use of intravitreal injection of triamcinolone acetonide in the treatment of age-related macular degeneration," *Indian J Ophthalmol.*, 2007, 55(6):431-435, (8 pages).

Griffin, W., "Classification of Surface-Active Agents by 'HLB'," *Journal of the Society of Cosmetic Chemists*, 1949, 1:311-326.

Hardung, H., "Semifluorierte und perfluorierte Verbindungen zur topischen und parenteralen Anwendung," 2008, English Language Abstract, 2 pages, retrieved from <https://freidok.uni-freiburg.de/data/5682> (retrieved on Jul. 10, 2017).

Hoerauf et al., "Combined Use of Partially Fluorinated Alkanes, Perfluorocarbon Liquids and Silicone Oil: An Experimental Study," *Graefe's Archive for Clinical and Experimental Ophthalmology*, 2001, 239(5):373-381.

Holm, R. et al., "A novel excipient, 1-perfluorohexyloctane shows limited utility for the oral delivery of poorly water-soluble drugs," *European Journal of Pharmaceutical Sciences*, 2011, 42: 416-422.

International Preliminary Report on Patentability dated Sep. 18, 2012, for International Patent Application PCT/EP2011/053949, 9 Pages.

International Preliminary Report on Patentability dated Apr. 23, 2013, for International Patent Application PCT/EP2011/068141, 4 Pages.

International Preliminary Report on Patentability dated May 14, 2013, for International Patent Application PCT/EP2011/069795, 8 Pages.

International Preliminary Report on Patentability dated Jul. 10, 2013, for International Patent Application PCT/EP2012/050043, 5 Pages.

International Preliminary Report on Patentability dated Nov. 26, 2013, for International Patent Application PCT/EP2012/059787, 9 Pages.

(56) **References Cited**

OTHER PUBLICATIONS

- International Preliminary Report on Patentability dated Nov. 26, 2013, for International Patent Application PCT/EP2012/059788, 8 Pages.
- International Preliminary Report on Patentability dated Jul. 29, 2014, for International Application No. PCT/EP2013/051163, 7 pages.
- International Preliminary Report on Patentability dated Mar. 17, 2015, for International Application No. PCT/EP2013/068882, 5 pages.
- International Preliminary Report on Patentability dated Mar. 17, 2015, for International Application No. PCT/EP2013/068909, 7 pages.
- International Preliminary Report on Patentability dated Jan. 26, 2016, for International Application No. PCT/EP2014/065840, 11 pages.
- International Search Report for International Application No. PCT/EP2011/053949 dated Sep. 6, 2011, 5 pages.
- International Search Report for International Application No. PCT/EP2011/068141 dated Dec. 14, 2011, 2 pages.
- International Search Report for International Patent Application PCT/EP2011/069795 dated Jan. 16, 2012, 3 pages.
- International Search Report for International Patent Application PCT/EP2012/050043 dated Apr. 24, 2012, 2 pages.
- International Search Report for International Application No. PCT/EP2012/059787 dated Dec. 5, 2012, 4 pages.
- International Search Report for International Application No. PCT/EP2012/059788 dated Dec. 3, 2012, 4 pages.
- International Search Report for International Application No. PCT/EP2013/051163 dated Mar. 4, 2013, 4 pages.
- International Search Report for International Application No. PCT/EP2013/068882 dated Oct. 30, 2013, 4 pages.
- International Search Report for International Application No. PCT/EP2013/068909 dated Dec. 5, 2013, 4 pages.
- International Search Report for International Application No. PCT/EP2014/065840 dated Oct. 7, 2014, 4 pages.
- International Search Report for International Application No. PCT/EP2016/073262 dated Nov. 18, 2016, 5 pages.
- International Search Report for International Application No. PCT/EP2016/073263 dated Dec. 23, 2016, 3 pages.
- International Search Report for International Application No. PCT/EP2017/083770 (revised version) dated Jul. 6, 2018, 4 pages.
- International Search Report for International Application No. PCT/EP2017/065163 dated Aug. 8, 2017, 3 pages.
- International Search Report and Written Opinion for International Application No. PCT/EP2017/083770 dated Jul. 6, 2018, 14 pages.
- Ishizaki et al., "Treatment of Diabetic Retinopathy", Forum: Complication, Practice, 2009, 26(5): 474-476 (3 pages).
- Jonas et al., "Intravitreal triamcinolone acetonide for exudative age-related macular degeneration," Br J Ophthalmol, 2003, 87:462-468.
- Joussen et al., "The concept of heavy tamponades—chances and limitations," Graefes Arch Exp Ophthalmol, 2008, 246:1217-1224. JP 2000511157A, English Machine Translation of the Abstract, Description, and Claims, Espacenet, Date Accessed: Feb. 10, 2016, 15 pages.
- JPS6452722, English Machine Translation of the Abstract, Description, and Claims, Espacenet, Date Accessed: Feb. 10, 2016, 4 pages.
- Kaercher et al., "NovaTears® as new Therapy in Dry Eye Results from three prospective, multicenter, non-interventional studies in different patient populations", TFOS Conference (Tear Film & Ocular Surface), Sep. 7-10, 2016, Montpellier, France, Poster Session II, Poster No. 60, 1 page.
- Knepp et al., "Stability of Nonaqueous Suspension Formulations of Plasma Derived Factor IX and Recombinant Human Alpha Interferon at Elevated Temperatures," Pharmaceutical Research, 1998, 15 (7):1090-1095.
- Kociok, N., "Influence on Membrane-Mediated Cell Activation by Vesicles of Silicone Oil or Perfluorohexyloctane," Graefes' Archive for Clinical and Experimental Ophthalmology, 2005, 243, 345-358.
- Lemp, M., "Management of Dry Eye Disease", The American Journal of Managed Care, 2008, 14(3):S88-S101.
- Lin, H. et al., "Thy eye disease: A review of diagnostic approaches and treatments," Saudi Journal of Ophthalmology, 2014, 28:173-181.
- Mackiewicz, J. et al., "In Vivo Retinal Tolerance of Various Heavy Silicone Oils," Investigative Ophthalmology & Visual Science, 2007, 48 (4):1873-1883.
- Mantle et al., "Adverse and Beneficial Effect of Plant Extracts on Skin Disorders," Adverse Drug Reaction and Toxicological Reviews, Oxford University Press, 2001, 20(2):89-103.
- Messmer et al., "Semifluorierte Alkane als Therapie bei Meibomdrüsen-Dysfunktion Ergebnisse einer prospektiven, multizentrischen Beobachtungsstudie", Presentation, DOG-Kongress, Sep. 29-Oct. 2, 2016, Berlin DOG (Deutsche Ophthalmologische Gesellschaft), Poster No. PSa03-02, 1 page (German language version).
- Messmer et al., "Semifluorinated Alkanes as a Therapy for Meibomian Gland Dysfunction Results of a prospective, multi-centered observational study", Presentation, DOG-Kongress, Sep. 29, 2016-Oct. 2, 2016, Berlin DOG (Deutsche Ophthalmologische Gesellschaft), Poster No. PSa03-02, English Translation, 6 pages.
- Messmer et al., "Semifluorinated Alkanes as a Therapy for Meibomian Gland Dysfunction Results of a prospective, multi-centered observational study", Presentation, DOG-Kongress, Sep. 29, 2016-Oct. 2, 2016, Berlin DOG (Deutsche Ophthalmologische Gesellschaft), Ophthalmologie, Aug. 2016 Poster No. PSa03-02, English Translation of Abstract, p. 138.
- Messmer, E.M., "The Pathophysiology, Diagnosis, and Treatment of Dry Eye Disease," (2015) Deutsches Arzteblatt International, 112(5):71-82.
- Murdan, S., "Enhancing the Nail Permeability of Topically Applied Drugs," Expert Opinion on Drug Delivery, 2008, 5(11), 1267-1282.
- Perry, "Dry Eye Disease: Pathophysiology, Classification, and Diagnosis," The American Journal of Managed Care, 2008, 14(3): S79-S87.
- Pflugfelder et al., "The Pathophysiology of Dry Eye Disease What We Know and Future Directions for Research," Ophthalmology (2017) 124(11 Supplement): S4-S13.
- Pinarci, E. et al., "Intraocular Gas Application in the Diagnosis and Treatment of Valsalva Retiopathy in Case with Premacular Hemorrhage," XP002625604, Retina Vitreus, 2009, 17 (2):153-155, 1 page, abstract only.
- Plassmann, M. et al., "Trace Analytical Methods for Semifluorinated n-Alkanes in Snow, Soil, and Air," Analytical Chemistry, 2010, 82(11):4551-4557.
- Plassmann, M. et al., "Theoretical and Experimental Simulation of the Fate of Semifluorinated n-Alkanes During Snowmelt," Environmental Science & Technology, 2010, 44(17):6692-6697.
- Rosca-Casian, O. et al., "Antifungal Activity of *Aloe vera* Leaves," Fitoterapia, 2007, 28:219-222.
- Rosenberg, A.S., "Effects of Protein Aggregates: An Immunologic Perspective," The AAPS Journal, 2006, 8 (3):E501-E507.
- Sall, K. et al. "Two Multicenter, Randomized Studies of the Efficacy and Safety of Cyclosporine Ophthalmic Emulsion in Moderate to Severe Dry Eye Disease," Ophthalmology, 2000, 107(4):631-639.
- Sato et al., "Vitrectomy and Intraocular Lens Implantation for Cytomegalovirus Retinitis in a Patient with Acquired Immunodeficiency Syndrome," Presented by Medical Online, New Ophthalmology, 1999, 16(7): 995-998 (4 pages).
- Schmutz et al., "Fluorinated Vesicles Made from Combinations of Phospholipids and Semifluorinated Alkanes. Direct Experimental Evidence of the Location of the Semifluorinated Alkane Within the Bilayer," Langmuir, 2003, 19:4889-4894.
- Schnettler et al., "Lipid composition of human meibum: a review," S Afr Optom, 2013, 72(2), 86-93.
- Spöler et al., "Towards a New in vitro Model of Dry Eye: The ex vivo Eye Irritation Test," Developments in Ophthalmology, 2010, 45, 93-107.
- Steven, P. et al. "Semifluorinated Alkane Eye Drops for Treatment of Dry Eye Disease—A Prospective, Multicenter Noninterventional Study" Journal of Ocular Pharmacology and Therapeutics (2015) vol. 31(8):498-503.

(56)

References Cited

OTHER PUBLICATIONS

Steven et al., "Semifluorinated Alkane Eye Drops for Treatment of Dry Eye Disease Due to Meibomian Gland Disease," *Journal of Ocular Pharmacology and Therapeutics*, 2017, 33(9):1-8.

Stevenson, C., "Characterization of Protein and Peptide Stability and Solubility in Non-Aqueous Solvents," *Current Pharmaceutical Biotechnology*, 2000, 1:165-182.

Thomas et al., "The therapeutic uses of topical vitamin A acid," *Journal of the American Academy of Dermatology*, 1981, 4(5): 505-513.

Tiffany, J.M., "Individual Variations in Human Meibomian Composition," *Exp. Eye Res.*, 1978, 27, 289-300.

Troiano et al., "Effect of Hypotonic .4% Hyaluronic Acid Drops in Dry Eye Patients: A Cross-Study", *Cornea* 27(10): 1126-1130, 1 page (Abstract Only).

Ujite et al., "Successful Treatment of Nail Lichen Planus with topical Tacrolimus", *Department of Dermatology*, Nov. 4, 2009, 2 pages.

Wang, W., "Lyophilization and Development of Solid Protein Pharmaceuticals," *International Journal of Pharmaceutics*, 2000, 203, 1-60.

"What is retinal vitrectomy?" Presented by: Medical Online, Obesity and Diabetes Mellitus, 2005, 4(2): 284-286, 3 pages.

Yaoxue Zhuanye Zhishi II (Editor: Jin Xiangqun), Military Medical Science Press, 1st Printing of 2nd Edition, Mar. 2009, p. 158.

Yaoxue Zhuanye Zhishi II (Editor: Jin Xiangqun), Military Medical Science Press, 1st Printing of 2nd Edition, Mar. 2009, p. 158, 3 pages (English Machine Translation).

Zakeri et al., "Topical calcipotriol therapy in nail psoriasis", A study of 24 cases, *Dermatology Online Journal*, 2005, 2 pages.

Zhang et al., "Surface micelles of semifluorinated alkanes in Langmuir-Blodgett monolayers," *Phys. Chem. Chem. Phys.*, 2004, 6:1566-1569.

English Translation of Notice of Reasons for Refusal, Issued in Japanese Application No. 2018-566545, dated Jul. 5, 2019, 4 pages.

* cited by examiner

Fig. 1

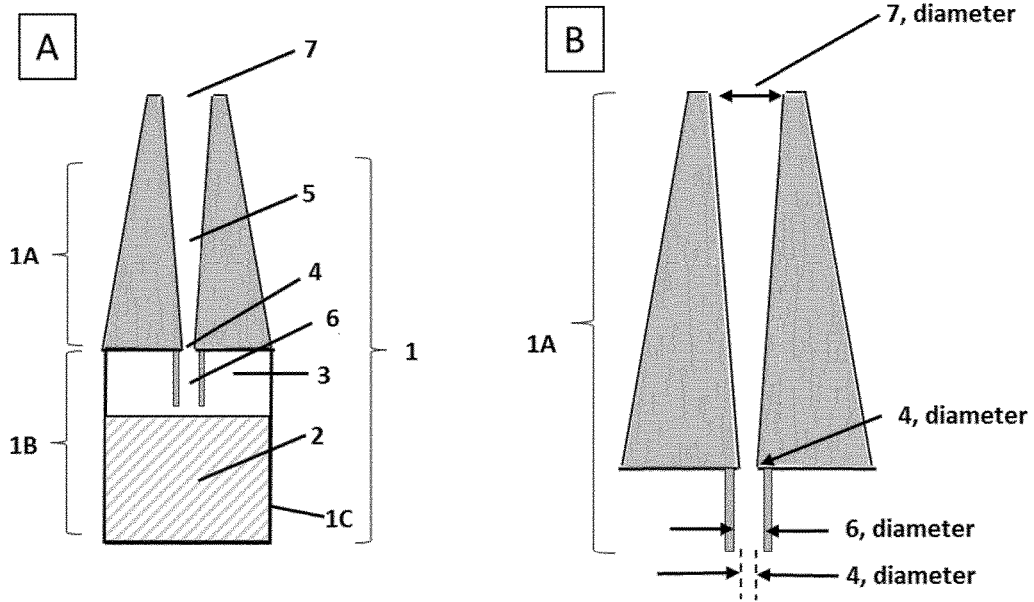

Fig. 2

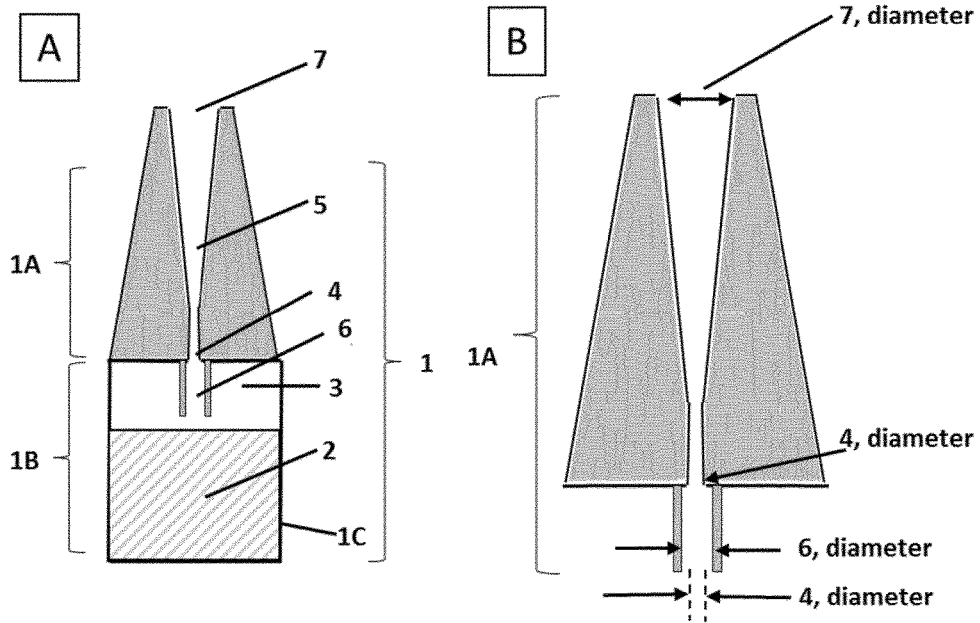

Fig. 3

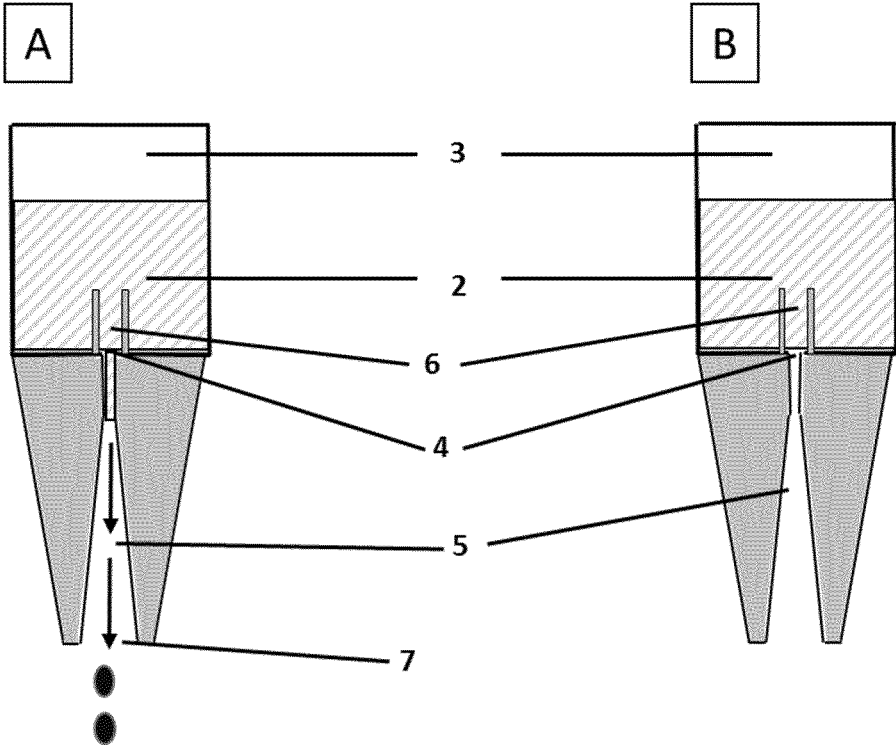

Fig. 4

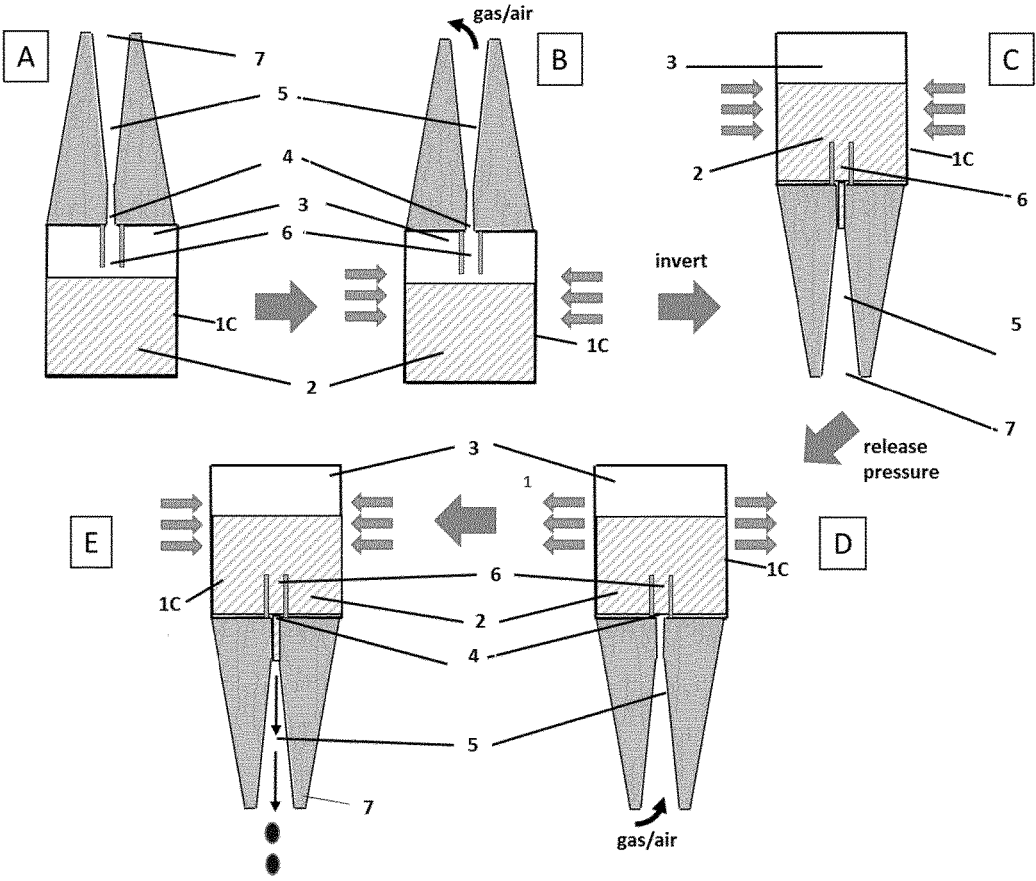

Fig. 5

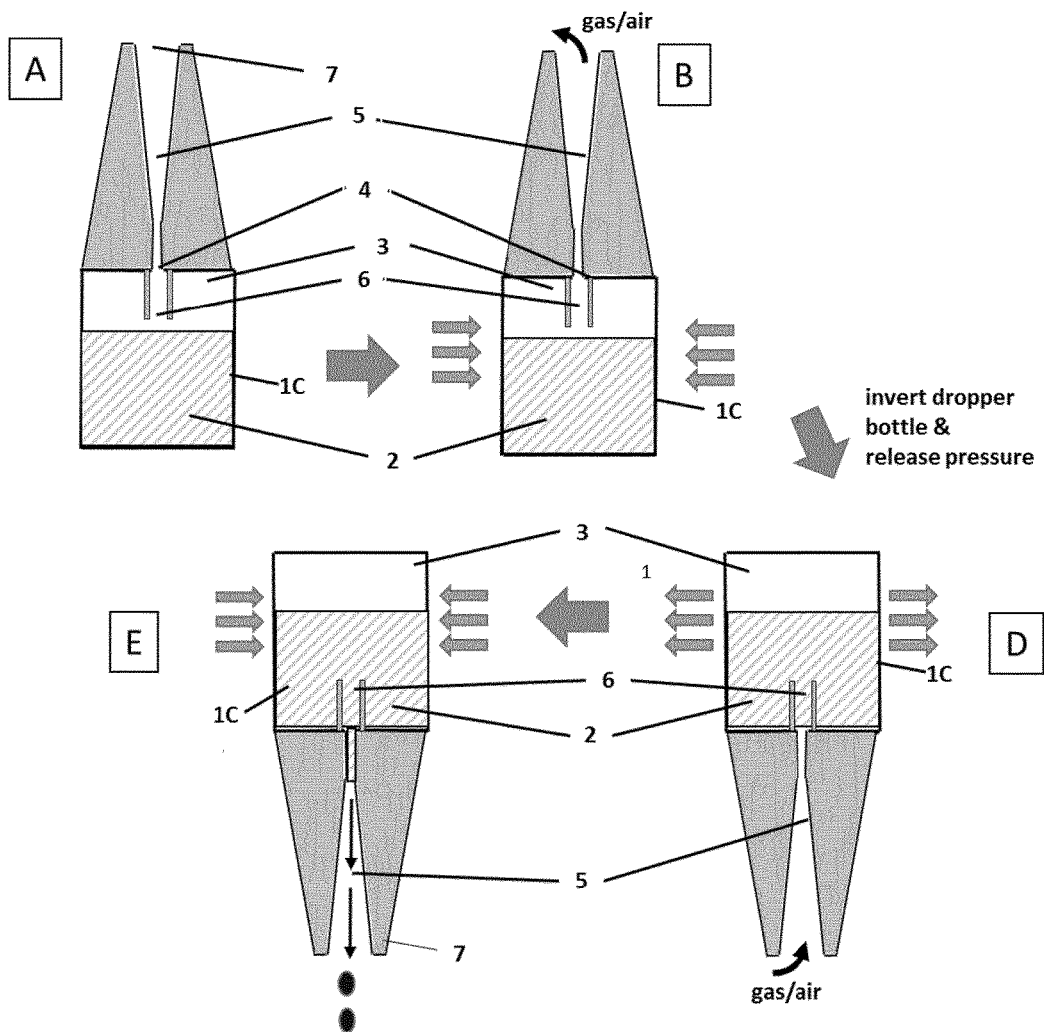

Fig. 6

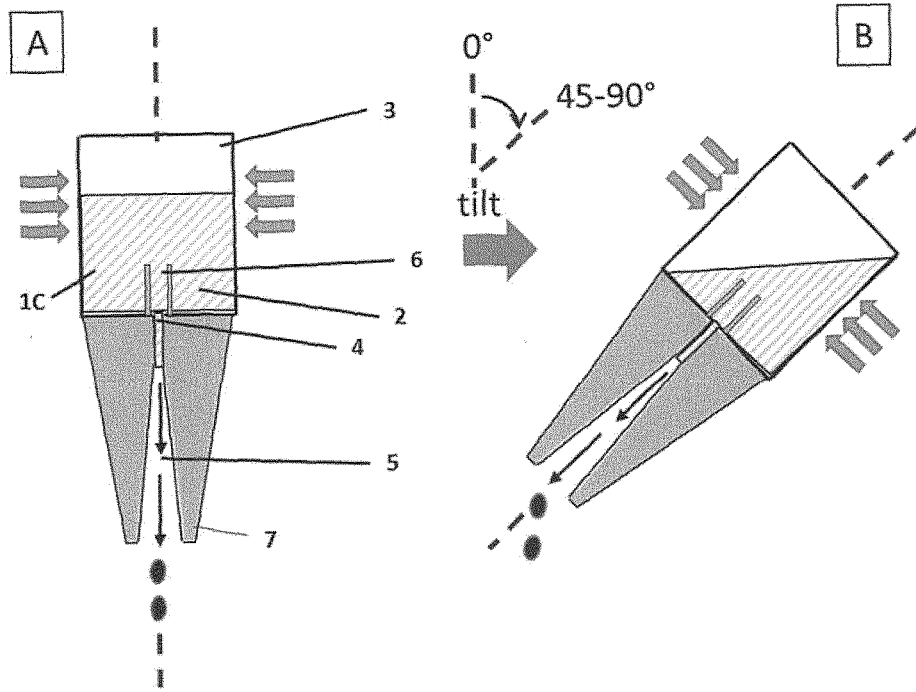

Fig. 7

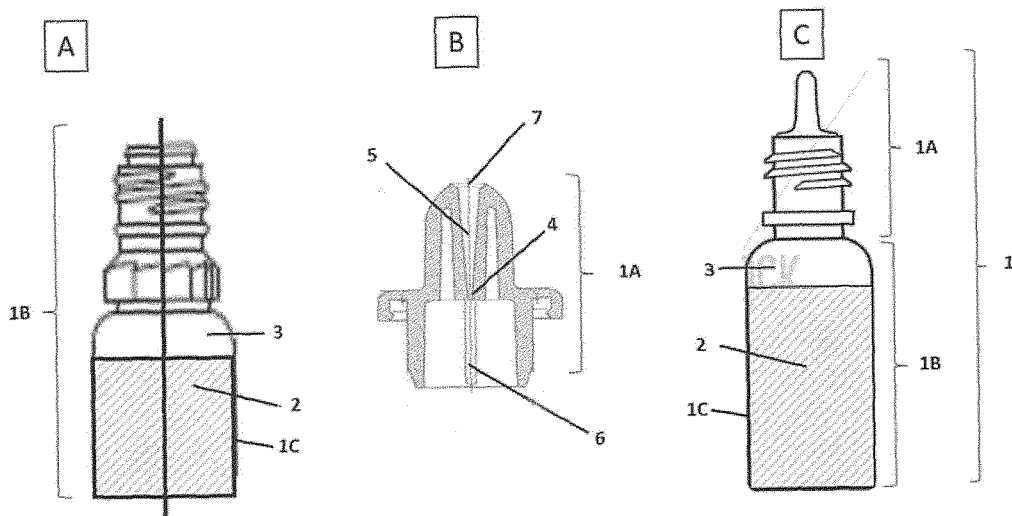
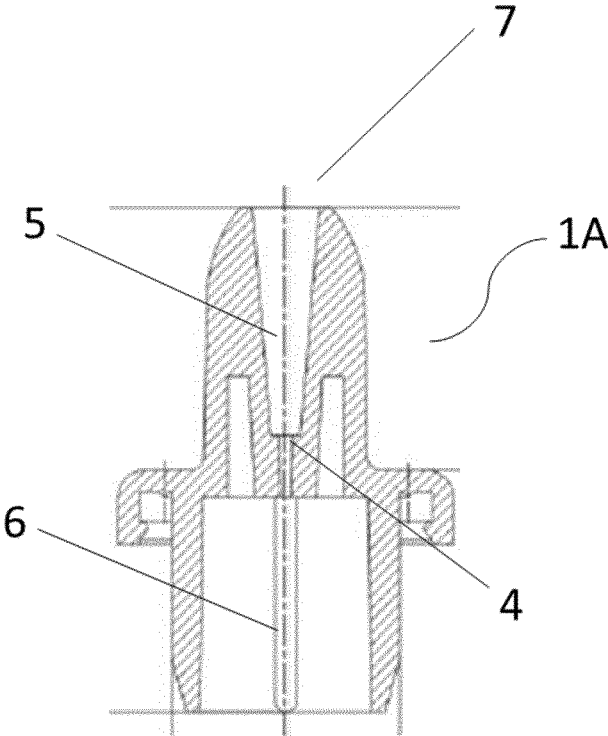

Fig. 8



TOPICAL ADMINISTRATION METHOD

Matter enclosed in heavy brackets [] appears in the original patent but forms no part of this reissue specification; matter printed in italics indicates the additions made by reissue; a claim printed with strikethrough indicates that the claim was canceled, disclaimed, or held invalid by a prior post-patent action or proceeding.

RELATED U.S. APPLICATION DATA

This application is a reissue of application Ser. No. 16/312,855, filed as application No. PCT/EP2017/065163 on Jun. 21, 2017, now U.S. Pat. No. 10,507,132.

CROSS-REFERENCE TO RELATED APPLICATIONS

This application is a reissue of Ser. No. 16/312,855, filed on Dec. 21, 2018, now U.S. Pat. No. 10,507,132, which is a U.S. national stage application filed under 35 U.S.C. § 371 of International Application No. PCT/EP2017/065163, filed on Jun. 21, 2017, which claims priority to, and the benefit of, European Application No. 16176074.9, filed Jun. 23, 2016, and European Application No. 16180202.0 filed Jul. 19, 2016, and European Application No. 17169837.6, filed May 6, 2017, the contents of each of which are incorporated herein by reference in their entireties.

FIELD

The present invention relates to a method for topical administration of ophthalmic compositions in a dropwise manner, preferably for topical administration of ophthalmic compositions comprising semifluorinated alkanes (SFAs). Further, the present invention relates to the use of said methods in the prevention or treatment of ocular diseases or disorders or any symptoms or conditions associated therewith. In a further aspect, the present invention relates to specific designs of a drop dispenser and to a kit comprising a drop dispenser at least partially filled with a liquid composition for the use in such a method and directions for use of said drop dispenser.

BACKGROUND

Semifluorinated alkanes (SFAs) are linear or branched compounds composed of at least one non-fluorinated hydrocarbon segment and at least one perfluorinated hydrocarbon segment. Semi-fluorinated alkanes have been described for various applications, for example commercially for unfolding and reapplying a retina, for long-term tamponade as vitreous humour substitute (H. Meinert et al., European Journal of Ophthalmology, Vol. 10(3), pp. 189-197, 2000), and as wash-out solutions for residual silicon oil after vitreo-retinal surgery.

WO2011/073134 discloses solutions of cyclosporine in semifluorinated alkanes of the formula $CF_3(CF_2)_n(CH_2)_mCH_3$, optionally in the presence of a co-solvent such as ethanol, wherein the semifluorinated alkane functions as a liquid drug delivery vehicle for cyclosporine for topical treatment of keratoconjunctivitis sicca.

WO2014/041055 describes mixtures of semifluorinated alkanes of the formula $CF_3(CF_2)_n(CH_2)_mCH_3$. These mixtures are described to be ophthalmically applicable as tear

film substitutes or for treating patients with dry eye syndrome and/or meibomian gland dysfunction.

It is known that the volume of drug instilled into the eye is of particular importance as it is one of the sources of drug response variation (German E. J. et. al, Eye 1999, 93-100).

Conventional eye drops are usually water-based compositions. When administering such water-based eye drops to the eye, the patient usually inverts the (eye-)dropper bottle that holds the ophthalmic composition and exerts a pressuring force to the flexible bottle in order to force one or more drops to be released from the (eye-)dropper bottle. This is usually done by simply squeezing the inverted eyedropper bottle resulting in the release of one or more drops (the aforementioned method is referred to as "pressure method" throughout this document).

Said conventional administration method (pressure method) known from water-based ophthalmic compositions is not suitable or not reliably suitable for administering ophthalmic compositions comprising SFAs, since SFA-comprising drops may be released from the eyedropper in a rather uncontrolled manner. Without being bound by theory, this is attributed to the interplay of the special surface properties of the amphiphilic SFAs, namely the interplay of high spreading capabilities, high density and/or low surface tension.

Furthermore, also an administration method that relies only on the inversion of the (eye-) dropper bottle without exerting a pressuring force to the bottle (the aforementioned method is referred to as "inversion method" throughout this document) is not suitable or not reliably suitable for administering ophthalmic compositions comprising SFAs, since SFA-comprising drops are also released from the eyedropper in a highly uncontrolled manner employing said inversion method. Again, this is attributed to the interplay of the special surface properties of the amphiphilic SFAs, namely the interplay of high spreading capabilities, high density and/or low surface tension.

Thus, it is an object of the present invention to establish a reliable method for the controlled administration, preferably for the controlled topical administration of compositions comprising semifluorinated alkanes (SFAs) to the eye in a drop-by-drop manner.

SUMMARY OF THE INVENTION

In a first aspect, the invention relates to a method for dropwise topical administration of a liquid composition (2), comprising the steps of:

- a) providing a drop dispenser (1), comprising
 - a container part (1B) with an interior volume partially filled with the liquid composition (2) and a gaseous phase (3) filling the remainder of the interior volume at ambient pressure, the container part (1B) having a displaceable section (1C) and optionally a substantially stationary section, and
 - a dropper part (1A) in physical connection and in fluid communication with the interior volume of the container part (1B), comprising an outflow channel (5), connecting the interior volume of the container part (1B) to the environment;
- b) exerting a first force to the displaceable section (1C) of the container part (1B) of the drop dispenser (1) while holding the drop dispenser (1) in an upright position in which the outflow channel (5) is not in contact with the liquid composition (2), thereby reducing the interior volume of the container part (1B) and forcing the

3

- gaseous phase (3) of the interior volume at least partially out of the drop dispenser (1) into the environment;
- c) inverting the drop dispenser (1) to an inverted position in which the liquid composition (2) is in contact with the outflow channel (5);
- d) releasing said first force from the displaceable section (1C) of the container part (1B) at least partly, thereby reducing the pressure inside the container part (1B) below ambient pressure; and
- e) exerting a second force to the displaceable section (1C) of the container part (1B), while still holding the drop dispenser in the inverted position in which the liquid composition (2) is in contact with the outflow channel (5), thereby raising the pressure inside the interior volume of the container part (1B) above ambient pressure and releasing the liquid composition (2) dropwise from the dropper part (1A) of the drop dispenser (1).

In a second aspect, the invention relates to the use of a method according to the first aspect of the invention for preventing or treating an ocular disease or disorder or any symptoms or conditions associated therewith.

In a third aspect, the invention relates to a method of treating an ocular disease or disorder or any symptoms or conditions associated therewith, comprising dropwise administration of a liquid ophthalmic composition according to the method according to the first aspect of the invention.

In a fourth aspect, the present invention relates to a drop dispenser (1), comprising

- a container part (1B) with an interior volume partially filled with the liquid composition (2) and a gaseous phase (3) filling the remainder of the interior volume at ambient pressure, the container part (1B) having a displaceable section (1C) and optionally a substantially stationary section, and
- a dropper part (1A) in physical connection and in fluid communication with the interior volume of the container part (1B), comprising an outflow channel (5), connecting the interior volume of the container part (1B) to the environment; wherein at least a portion of the outflow channel (5) has an inner diameter in the range of 0.09 to 0.19 mm.

In a fifth further aspect, the invention relates to a kit comprising

- a drop dispenser (1) at least partially filled with a liquid composition (2) and a gaseous phase (3) for the use in a method according to the first aspect of the invention and

directions for use of the drop dispenser (1) in a method according to the first aspect of the invention.

Surprisingly, it was found that the administration of drops or droplets of compositions comprising semifluorinated alkanes to the eye is preferably performed utilizing an underpressure in the (eye-)dropper bottle. By generating an underpressure in the interior volume of the dropper bottle, uncontrolled release of said compositions comprising semifluorinated alkanes contained in the dropper bottle is effectively prevented and reliable administration of said compositions in a dropwise manner is safeguarded. This allows for reproducible dosing of compositions comprising SFAs to the eye, including compositions comprising pharmaceutical active ingredients as well as compositions comprising no pharmaceutical active ingredients. The reliable administration is especially important to the administration of therapeutic compositions comprising semifluorinated alkanes since the corresponding drop volumes (approximately in the range of 5 to 15 μl , in many cases in the range of 8 to 15 μl)

4

are much smaller (as compared to aqueous eye drops) and are thus more prone to overdosing or dose variation.

Further, the inventors found that the method of the present invention, employing an underpressure in the dropper bottle, not only works for compositions comprising SFAs, but also for conventional water-based ophthalmic compositions. Thus, the inventors of the present invention surprisingly found a universal administration method for ophthalmic compositions, including water-free (e.g. SFA-based) or water-based compositions. By using the method of the first aspect of the present invention (said method is also referred to as "underpressure method" throughout this document) ophthalmic compositions can be administered to the eye in a highly-controlled fashion, which safeguards the reliably and reproducibly administration of a defined dose of said ophthalmic compositions to the eye.

Even further, the inventors found that the method according to the first aspect of the present invention, employing an underpressure, works reliable also below ambient temperature, namely with ophthalmic compositions that were stored below ambient temperature (e.g. refrigerated compositions), which is problematic when using the pressure method as well as the inversion method, especially in the case of SFA-based compositions. Employing the present invention, said compositions may be directly administered without the need to equilibrate the composition to ambient temperature before use. The method according to the first aspect of the present invention (underpressure method) also works regardless of the volume of the headspace (gaseous volume that fills the remainder of the interior volume of the dropper bottle in addition to the liquid (ophthalmic) composition) in the dropper bottle. During ongoing use of the composition, the volume of the headspace is continuously increasing, as the volume of the liquid ophthalmic composition is decreasing. Such increasing headspace volume hampers reliable administration of ophthalmic compositions utilizing the pressure method or inversion method, especially when SFA-based compositions are employed—which is not the case when the underpressure method according to the present invention is employed.

BRIEF DESCRIPTION OF THE DRAWINGS

FIG. 1(A): Schematic representation of a drop dispenser (dropper bottle) (1) in the upright position

FIG. 1(B): Schematic representation of a dropper part (1A)

FIG. 2(A): Schematic representation of a slightly different configuration of a drop dispenser (1) in the upright position

FIG. 2(B): Schematic representation of a dropper part (1A)

FIG. 3(A): Schematic representation of a drop dispenser (dropper bottle) (1) in the inverted (downside) position

FIG. 3(B): Schematic representation of a drop dispenser (dropper bottle) (1) in the inverted (downside) position

FIG. 4: Schematic representation of the administration method of the present invention (underpressure method)

FIG. 5: Schematic representation of an embodiment of the method of the present invention

FIG. 6: Schematic representation of alternative inverted positions of a drop dispenser (1)

FIG. 7: Schematic representation of a drop dispenser (dropper bottle) (1) comprising a container part (bottle part) (1B) and a dropper part (1A)

5

FIG. 8: Schematic representation of a dropper part (1A) of a drop dispenser (dropper bottle)

DETAILED DESCRIPTION OF THE INVENTION

The terms “consist of”, “consists of” and “consisting of” as used herein are so-called closed language meaning that only the mentioned components are present. The terms “comprise”, “comprises” and “comprising” as used herein are so-called open language, meaning that one or more further components may or may not also be present.

The term “active pharmaceutical ingredient” (also referred to as “API” throughout this document) refers to any type of pharmaceutically active compound or derivative that is useful in the prevention, diagnosis, stabilization, treatment, or—generally speaking—management of a condition, disorder or disease.

The term “therapeutically effective amount” as used herein refers to a dose, concentration or strength which is useful for producing a desired pharmacological effect.

According to the first aspect the present invention provides a method for dropwise topical administration of a liquid composition (2), comprising the steps a) to e) which will be described in further detail below.

The term “dropwise” as used herein means that a liquid, more specifically the liquid composition of the present invention is provided in a drop-by-drop fashion, which means that one discrete drop, irrespective of its size or volume, is provided or administered at a time and/or that a plurality of drops or droplets, preferably of the liquid composition, is provided in a consecutive manner, one at a time.

Further, according to the present invention, dropwise administration of the liquid composition is performed topically, meaning on the surface, e.g. to the skin or other outer boundary of a human or animal body or any part thereof. Preferably, the liquid composition is topically administered to the eye surface or an eye tissue.

The term “liquid composition” according to the present invention means any water-containing or water-free liquid, solution, emulsion or dispersion, preferably a liquid solution that may be applied to the human or animal body and that may optionally contain one or more active pharmaceutical ingredient (API) as defined above or further compounds like excipients, may optionally contain one or more active pharmaceutical ingredient (API) as defined above or further compounds like excipients, such as organic solvents, lipids, oils, lipophilic vitamins, lubricants, viscosity agents, acids, bases, antioxidants, stabilizers, synergists, coloring agents, thickening agents,—and if required in a particular cases—a preservative or a surfactant and mixtures thereof.

Potentially useful organic solvents include, but are not limited to, glycerol, propylene glycol, polyethylene glycol, ethanol, acetone, ethyl acetate, isopropyl alcohol, pentylene glycol, liquid paraffin, triglyceride oils and hydrofluorocarbons.

Potentially useful lipids or oily excipients include, but are not limited to, triglyceride oils (e.g. soybean oil, olive oil, sesame oil, cotton seed oil, castor oil, sweet almond oil), mineral oil (e.g. petrolatum and liquid paraffin), medium chain triglycerides (MCT), oily fatty acids, isopropyl myristate, oily fatty alcohols, esters of sorbitol and fatty acids, oily sucrose esters, oily cholesterol esters, oily wax esters, glycerophospholipids, sphingolipids, or any oily substance which is physiologically tolerated by the eye.

6

Potentially useful antioxidants include, but are not limited to, vitamin E or vitamin E derivatives, ascorbic acid, sulphites, hydrogen sulphites, gallic acid esters, butyl hydroxyanisole (BHA), butyl hydroxytoluene (BHT) or acetylcysteine.

According to step a) of the administration method according to the first aspect of the present invention a drop dispenser (1) is provided. A “drop dispenser” as used herein may be a container, dispenser, applicator or bottle of any suitable kind for handheld use which can hold at least a single dose, preferably multiple doses of the liquid composition and which may be designed of a single piece or multiple pieces or parts and which may typically be made of a material which is essentially inert against the liquid composition to be administered and which may be rigid such as glass (especially when used in a combination with a flexible material) or preferably flexible, such as, for example polyethylene or polypropylene. In a preferred embodiment of the present invention the container part (1B) of the drop dispenser (1) is at least partially made of a flexible polymer, preferably of a flexible thermoplastic polymer.

The drop dispenser provided in step a) of the present invention comprises a container part (1B) and a dropper part (1A). The “container part” is the portion of the drop dispenser which holds the liquid composition to be administered dropwise in the amount of a single dose, preferably however in an amount of multiple doses or drops, typically in an amount of 0.1 to 15 ml, more typically in an amount of 0.1 to 10 ml, even more typically in an amount of 0.1 to 5 ml. The container part holds an interior space or volume which is at least partially filled with the liquid composition to be administered. The container part (1B) also holds a gaseous phase (3) which fills the remainder of the interior volume which is not filled with the liquid composition (2). The gaseous phase typically consists of air or a protective gas or a mixture of air and a protective gas or a mixture of different protective gases and evaporated portions or traces of the components of the liquid composition (2). According to step a) of the present method the gaseous phase (3) as well as the liquid composition (2) is held under ambient pressure, which means that it is under the same pressure as the surrounding atmospheric pressure, at least after the container has been opened.

The container part (1B) of the drop dispenser according to step a) has a displaceable section (1C) and optionally a substantially stationary section. The term “displaceable section” as used herein may be any portion or area of the container part (1B) that may be displaced out of its original position relative to a fixed portion of the drop dispenser, e.g. relative to dropper part of the drop dispenser by an external force applied, for example by pressing, pushing, shifting, tilting or bending out of its original position to a displaced position without affecting the physical integrity of the container part (1B). Preferably the displacement of the displaceable section (1C) of the container part (1B) induces a deformation, preferable a reversible deformation of the container part, in which the inner volume of the container part is reduced. Optionally the container part (1B) may also comprise a stationary or substantially stationary section which is not or substantially not displaced together with the displaceable section when an external force is applied. The stationary section may or may not be present and may be a separate part connected to the displaceable section or may be a portion of the displaceable section which may not be displaced relative to fixed portion of the drop dispenser.

The drop dispenser provided in step a) of the present invention also has a dropper part (1A). The “dropper part”

is the portion of the drop dispenser through which the liquid composition (2) is discharged from the container part (1B) and subsequently administered. It is physically connected to the container part (1B) and connects the interior volume of the container part (1B) to the environment through an outflow channel (5) through which the liquid composition (2) to be administered is discharged. The outflow channel may optionally comprise a drop brake channel (6) which elongates the outflow channel further into the interior volume of the container part (1B).

According to step b) of the administration method of the present invention a first force is exerted to the displaceable section (1C) of the container part (1B) of the drop dispenser (1) while the drop dispenser is held in an upright position. The term "upright position" means that the drop dispenser is oriented such that the outflow channel (5) or the optional drop brake channel (6) is not in contact with the liquid composition (2) held in the container part. This is usually the case when the dropper part comprising the outflow channel is oriented upwards and the liquid composition, by the force of gravity, is held in the lowermost part, i.e. the bottom end of the drop dispenser. In this orientation, the outflow channel only contacts the gaseous phase (3) and not the liquid composition (2). Accordingly, the term "upright position" also encompasses orientations of the drop dispenser which are not completely perpendicular. It also encompasses inclined orientations of the dispenser with an inclination angle of up to 90°, often with an inclination angle of approximately 0° to 45°, more often with an inclination angle of approximately 0° to 30° between the normal axis of the drop dispenser (1) and a perpendicular reference line, as long as the liquid composition does not contact the outflow channel (5) or the optional drop brake channel (6).

Preferably, the first force is a pressuring force exerted to the displaceable section of the container part (1B), for example a pressuring force applied by the fingers of a user of the drop dispenser to a flexible wall of the container part (1B). Thereby the interior volume of the container part of the drop dispenser is reduced and the gaseous phase is at least partly or in whole, preferably partly, forced out of the drop dispenser (1) into the environment.

According to step c) of the method of the present invention the drop dispenser is then inverted to an inverted position in which the liquid composition is in contact with the outflow channel (5) or, if present, the optional drop brake channel (6). The term "inverted position" as used herein means that the drop dispenser is oriented such that the outflow channel (5) or the optional drop brake channel (6) is in contact with liquid composition (2) held in the container part. This is usually the case when the dropper part comprising the outflow channel is oriented downwards and the liquid composition, by the force of gravity, is held in the lowermost end of the drop dispenser. In this orientation, the outflow channel only contacts the liquid composition (2) and not the gaseous phase (3). Accordingly, the term "inverted position" also encompasses orientations of the drop dispenser (1) which are not completely perpendicular. It also encompasses inclined orientations of the dispenser with an inclination angle of up to 90°, often with an inclination angle of approximately 0° to 45°, more often with an inclination angle of approximately 0° to 30° between the normal axis of the drop dispenser (1) and a perpendicular reference line, as long as the liquid composition is in contact with the outflow channel (5) or the optional drop brake channel (6) of the dropper part.

According to step d) of the method of the present invention said first force exerted to the displaceable section (1C)

of the container part (1B) in step b) is at least partly released while still holding the drop dispenser in the inverted position. Thereby, the inner volume of the container part (1B) is enlarged or allowed to enlarge and the pressure inside the container part (1B) is at least temporarily reduced below ambient pressure (also termed as "underpressure" in this document). This allows air from the environment to enter in the outflow channel (5) of the dropper part and prevents any liquid composition (2) from leaking unintentionally or uncontrolled from the outflow channel (5).

According to step e) of the method of the present invention a second force is exerted to the displaceable section (1C) of the container part (1B), while still holding the drop dispenser in the inverted position in which the liquid composition (2) is in contact with the outflow channel (5). In a preferred embodiment, the second force is the same kind of force as applied according to step b), preferably also a pressuring force applied by the fingers of a user of the drop dispenser to a flexible wall of the container part (1B). By exerting the second force to the displaceable part (1C) of the drop dispenser (1) the pressure inside the interior volume of the container part (1B) is raised at least temporarily above ambient pressure and the liquid composition (2) is released dropwise from the dropper part (1A) of the drop dispenser (1).

In a further embodiment, the administration method according to the present invention optionally comprises the additional step

f) dropwise administering the composition to the eye, preferably to the eye lid, eye sac or an ophthalmic tissue of a subject in need thereof.

In a preferred embodiment of the present invention the drop dispenser (1) as described above is a dropper bottle (1) with a dropper part (1A) and a container part (1B), the container part (1B) comprising the displaceable section (1C).

The term "dropper bottle" (1) as used in connection with this preferred embodiment of the invention refers to a medical device that is/may be used as an eye drop delivery system (eyedropper), but which may also be helpful in administering certain compositions in a drop-by-drop manner to other parts of the body that are accessible to topical administration, such as ear, skin, nose, head, finger or other limbs. A dropper bottle may comprise a bottle part (1B) and a dropper part (1A) (see FIGS. 1-7). The bottle part (1B) is for holding the liquid ophthalmic composition to be released in a drop-by drop manner according to the present invention.

The term "bottle part" (1B) of the dropper bottle, as used herein refers to part of the dropper bottle (1) that holds the liquid (ophthalmic) composition (2) to be administered in its interior volume. Besides the liquid (ophthalmic) composition (2) the remaining part of the interior volume is filled by a gaseous phase (3). As described above, said gaseous phase (3) may comprise air or another gas, such as an inert gas (e.g. argon, nitrogen). It is understood that, as the volume of the liquid composition (2) is decreasing upon repeated use/release of drops, the volume of the gaseous phase (3) is correspondingly increasing.

The "dropper part" (1A) as used herein refers to the part of the dropper bottle (1) from which the liquid (ophthalmic) composition is physically released in a dropwise, i.e. in a drop-by-drop manner. The dropper part (1A) is or may be mounted onto the bottle part (1B), connecting the interior volume of the bottle part to the environment. This connection (fluid communication) of the interior volume to the environment is effected in sequential order (from the distal to the proximal end) by the optional drop brake channel (6)

(see FIGS. 1 to 7) to the outflow channel (5) with the duct opening (4) at its distal end and the dropper mouth (7) at its proximal end. Said fluid communication allows both the liquid ophthalmic composition (2), as well as the gaseous phase (3) to be released from the dropper bottle (1) to the environment.

The term “deformable wall part (1C)” as used herein in connection with the dropper bottle of this embodiment of the invention refers to the wall part of the bottle part (1B) of the dropper bottle (1), which is fabricated in such that it allows to be deformed by a pressuring force exerted to it. The deformation of the wall part (1C) effects the interior volume to be compressed, resulting in the release of the gaseous phase (3) and/or the liquid (ophthalmic) composition (2) from the interior volume to the environment, as well as the intake of a gaseous phase (e.g. air) into the interior volume. The deformable wall part is preferably manufactured from a at least partially deformable material, preferably from an at least partially deformable plastic material, such as polypropylene or polyethylene. More preferably the deformable wall part is preferably manufactured from a at least partially manually deformable plastic material.

Preferably, the deformable wall part is manufactured from an at least partially manually deformable plastic material with a preferred thickness in the range of from 0.4 to 1.6 mm, preferably with a thickness in the range of from 0.5 to 1.0 mm, more preferably with a thickness in the range of from 0.6 to 0.8 mm.

The term “dropper brake channel” (6) of the dropper bottle according to this preferred embodiment of the invention as used herein refers to an optional channel-like device that extends from the duct opening (4) of the outflow channel (5) into the interior volume of the bottle part. When present, the dropper brake channel (6) is in fluid communication with the interior volume of the bottle part (1B) and with the outflow channel (5). The dropper brake channel may act as a means to limit or reduce the flow of the ophthalmic composition upon inversion of the dropper bottle (1).

The term “duct opening (4)” of the dropper bottle as used herein refers to the most distal end of the outflow channel (5). The duct opening (4) is preferably circular and/or has a preferred diameter in the range of from 0.15 to 1.2 mm, preferably its diameter is in the range of from 0.18 to 0.5 mm, more preferably its diameter is in the range of from 0.2 to 0.3 mm.

The term “outflow channel (5)” as used in connection with this embodiment of the invention refers to a channel-like device that connects the interior volume of the dropper bottle (1) to the environment, safeguarding the fluid (or gaseous) communication between interior volume and the environment. Herein, the outflow channel (5) is delimited at its distal end by the duct opening (4) located inside the interior volume of the dropper bottle and by the dropper mouth (7) at its very proximal end located outside the interior volume of the dropper bottle.

Upon administration, the liquid, preferably the liquid ophthalmic composition is delivered from interior volume through the outflow channel (5) to the dropper mouth (7), where the composition is released in a drop-by-drop manner. The outflow channel (5) is preferably a circular channel. Preferably, the outflow channel (5) has different diameters at its distal end (duct opening (4)) and at its proximal end (dropper mouth (7)). In one embodiment, the diameter at the distal end (duct opening (4)) is smaller than the diameter at the proximal end (dropper mouth (7)). In this embodiment, the outflow channel is narrowing from the proximal dropper

mouth (7) to the distal duct opening (4). In still a further embodiment, the diameter at the distal end (duct opening (4)) is larger than the diameter at the proximal end (dropper mouth (7)).

The term “dropper mouth” (7) as used in this embodiment refers to the most proximal end of the outflow channel (5), where the drops to be released are formed. The diameter of the dropper mouth (7) is preferably circular and/or its diameter is preferably in the range of 1 to 5 mm, preferably its diameter is in the range of 2 to 3 mm, more preferably its diameter is in the range of 2.0 to 2.6 mm, even more preferably its diameter is in the range of about 2.0 to 2.4 mm.

The term “pressuring force” as used in this preferred embodiment refers to a force that is applied to the deformable wall part (1C) to effect the interior volume of the bottle part (1B) to be compressed. Preferably, said force is by manually pressuring the deformable wall part (1C), e.g. by manually squeezing.

In a further preferred embodiment, the administration method according to the present invention, the inversion of the drop dispenser (1) to the inverted position according to step (c) and the release of the first force according to step (d) is performed at least partly simultaneously. This means that the release of the first force, preferably the first pressuring force exerted to the displaceable part (1C) of the drop dispenser may or may not be performed in whole or in part during the inversion of the drop dispenser according to step c). Preferably, however, the release of the first force does not start, before the contact between the liquid composition and the outflow channel (5) is established. Irrespective of whether or not steps c) and d) are performed simultaneously in whole or in part the administration method according to the present invention it is beneficial and preferred when upon release of the first force in step d) air is at least partially sucked into the outflow channel (5) forming a barrier to prevent uncontrolled release of the liquid composition (2) from the dropper dispenser (1). Therefore, according to this beneficial embodiment of the present invention the reduced pressure generated inside the interior volume of the container part (1B) prevents the unintended, in many cases non-dropwise and therefore non-reproducible release of the liquid composition (2) from the drop dispenser (1).

In a further embodiment of the first aspect of the invention, the method optionally further comprises the steps:

- g) releasing the second pressuring force from the displaceable part (1C) of the container or bottle part (1B), while still holding the drop dispenser or dropper bottle respectively in the inverted position, thereby stopping the release of the liquid composition (2), and
- h) optionally exerting one or more further pressuring force(s) to the displaceable or deformable wall part (1C) of the container or bottle part (1B), while still holding the drop dispenser or dropper bottle in an inverted position, thereby releasing further liquid composition (2) in a dropwise manner from the dropper part (1A) and subsequently releasing the one or more further pressuring force(s) from the displaceable part (1C) of the container or bottle part (1B).

The liquid composition utilized in the method of the present invention may be a water-containing or alternatively a water-free composition. Examples of composition successfully utilized in practicing the method of the present invention are listed in Table 2.

In a further preferred embodiment of the present invention the liquid composition (2) to be administered in a dropwise fashion is an ophthalmic composition, whereas the term “ophthalmic” as used herein means that the liquid compo-

sition can be topically administered to the eye, to the eye surface or to an eye tissue of a human or an animal.

The liquid composition may comprise water, dissolved salts, buffer solutions and solvents known to those of skill in the art to be compatible with the above-described ophthalmic administration.

Accordingly, a broad diversity of commercially available, water-based ophthalmic compositions, such as e.g. Systane®, Arteleac®, Refresh (see Table 2) and the like are suited as liquid compositions (2) to be administered according to the method of the present invention.

Further, the liquid composition (2) may comprise one or more excipients, such as an organic cosolvent, such as an oil selected from glyceride oils, liquid waxes, and liquid paraffin or mineral oil, or said liquid composition may comprise an organic solvent exhibiting a high degree of biocompatibility, such as glycerol, propylene glycol, polyethylene glycol or ethanol.

The liquid composition (2) to be administered may be used in form of a solution or a suspension or an emulsion. Further, it may generally be used at different temperatures, such as different room or ambient temperatures. Furthermore, it may be used in a cooled state, for example after storage in a cooler or freezer. Typically, the liquid composition (2) to be administered may be used at a temperature (of the liquid, not necessarily of the surroundings) of approximately from -15 to 40°C ., more typically of from -10°C . to 37°C . In a preferred embodiment of the present invention the liquid composition has a temperature in the range from -7°C . to 30°C ., preferably in the range from 20°C . to 30°C .

The liquid composition (2) optionally comprises one or more pharmaceutical active ingredients (APIs) such as for example: prostaglandin analogs (e.g. latanoprost, unoprostone, travoprost, bimatoprost, tafluprost), β -blockers, (e.g. timolol, brimonidine), carbonic anhydrase inhibitors (e.g. acetazolamide, dorzolamide, methazolamide, brinzolamide), antihistamines (e.g. olopatadine, levocabastine), corticosteroids (e.g. loteprednol, prednisolone, dexamethasone), fluorquinolone antibiotics (e.g. moxifloxacin, gatifloxacin, ofloxacin, levofloxacin), aminoglycoside antibiotics (e.g. tobramycin), macrolide antibiotics (e.g. azithromycin), VEGF-inhibitors (e.g. ranibizumab, bevacizumab, aflibercept), macrolide immunosuppressants (e.g. cyclosporine, tacrolimus, sirolimus), NSAIDs (e.g. bromfenac, nepafenac, diclofenac, ketorolac).

In a preferred embodiment, the liquid composition (2) to be topically administered according to present invention comprises a liquid semifluorinated alkane or a mixture of two or more different semifluorinated alkanes.

The term "semifluorinated alkane" (also referred to as "SFA" throughout this document) refers to a linear or branched compound composed of at least one perfluorinated segment (F-segment) and at least one non-fluorinated hydrocarbon segment (H-segment). More preferably, the semifluorinated alkane is a linear or branched compound composed of one perfluorinated segment (F-segment) and one non-fluorinated hydrocarbon segment (H-segment). Preferably, said semifluorinated alkane is a compound that exists in a liquid state at least at one temperature within the temperature range of 4° to 40°C ., with the perfluorinated segment and/or the hydrocarbon segment of the said SFA optionally comprising or consisting of a cyclic hydrocarbon segment, or optionally said SFA within the hydrocarbon segment comprising an unsaturated moiety.

Preferably, the F-segment of a linear or branched SFA comprises between 3 to 10 carbon atoms. It is also preferred

that the H-segment comprises between 3 to 10 carbon atoms. It is particularly preferred that the F- and the H-segment comprise, but independently from one another, 3 to 10 carbon atoms. Preferably, each segment independently from another is having carbon atoms selected from the range of 3 to 10.

It is further preferred, that the F-segment of a linear or branched SFA comprises between 4 to 10 carbon atoms and/or that the H-segment comprises between 4 to 10 carbon atoms. It is particularly further preferred that the F- and the H-segment comprise, but independently from one another, 4 to 10 carbon atoms. Preferably, each segment is independently from another having carbon atoms selected from the range of 4 to 10.

Optionally, the linear or branched SFA may comprise a branched non-fluorinated hydrocarbon segment comprising one or more alkyl groups selected from the group consisting of $-\text{CH}_3$, C_2H_5 , C_3H_7 and C_4H_9 and/or the linear or branched SFA may comprise a branched perfluorinated hydrocarbon segment, comprising one or more perfluorinated alkyl groups selected from the group consisting of $-\text{CF}_3$, C_2F_5 , C_3F_7 and C_4F_9 .

It is further preferred that the ratio of the carbon atoms of the F-segment and the H-segment (said ratio obtained by dividing the number of carbon atoms in the F-segment by the numbers of carbon atoms in the H-segment; e.g. said ratio is 0.75 for 1-perfluorohexyloctane (F6H8)) of a linear or branched SFA is 0.5, more preferably said ratio is 0.6. It is further preferred that the ratio of the carbon atoms of the F-segment and the H-segment is in the range between 0.6 and 3.0, more preferably said ratio is between 0.6 and 1.0.

In a preferred embodiment of the present invention the semifluorinated alkane refers to a linear compound composed of at least one perfluorinated segment (F-segment) and at least one hydrocarbon segment (H-segment). More preferably, said semifluorinated alkane is a linear compound composed of one perfluorinated segment (F-segment) and one hydrocarbon segment (H-segment).

According to another nomenclature, the linear semifluorinated alkanes may be referred to as FnHm, wherein F means the perfluorinated hydrocarbon segment, H means the non-fluorinated hydrocarbon segment and n, m is the number of carbon atoms of the respective segment. For example, F4H5 is used for 1-perfluorobutylpentane.

Preferably, the F-segment of a linear SFA comprises between 3 to 10 carbon atoms. It is also preferred that the H-segment comprises between 3 to 10 carbon atoms. It is particularly preferred that the F- and the H-segment comprise, but independently from one another, 3 to 10 carbon atoms. Preferably, each segment independently from another is having carbon atoms selected from the range of 3 to 10.

It is further preferred, that the F-segment of a linear SFA comprises between 4 to 10 carbon atoms and/or that the H-segment comprises between 4 to 10 carbon atoms. It is particularly further preferred that the F- and the H-segment comprise, but independently from one another, 4 to 10 carbon atoms. Preferably, each segment is independently from another having carbon atoms selected from the range of 4 to 10.

Optionally, the linear SFA may comprise a branched non-fluorinated hydrocarbon segment comprising one or more alkyl groups selected from the group consisting of $-\text{CH}_3$, C_2H_5 , C_3H_7 and C_4H_9 and/or the linear SFA may comprise a branched perfluorinated hydrocarbon segment, comprising one or more perfluorinated alkyl groups selected from the group consisting of $-\text{CF}_3$, C_2F_5 , C_3F_7 and C_4F_9 . It is further preferred that the ratio of the carbon atoms of the

F-segment and the H-segment (said ratio obtained by dividing the number of carbon atoms in the F-segment by the numbers of carbon atoms in the H-segment; e.g. said ratio is 0.75 for 1-perfluorohexyloctane (F6H8)) of a linear SFA is 0.5, more preferably said ratio is ≥ 0.6 . It is further preferred that the ratio of the carbon atoms of the F-segment and the H-segment is in the range from 0.6 to 3.0, more preferably said ratio is in the range from 0.6 to 1.0.

Preferably, the semifluorinated alkane is a linear compound of the formula $F(CF_2)_n(CH_2)_mH$ wherein n and m are integers independently selected from the range of 3 to 10, more preferably the semifluorinated alkane is a linear compound of the formula $F(CF_2)_n(CH_2)_mH$ wherein n and m are integers independently selected from the range of 4 to 10. Even more preferred the semifluorinated alkane is a liquid of the formula $F(CF_2)_n(CH_2)_mH$ wherein n and m are integers independently selected from the range of 4 to 10.

Preferably, the linear SFA is selected from the group consisting of F4H4, F4H5, F4H6, F4H7, F4H8, F5H4, F5H5, F5H6, F5H7, F5H8, F6H2, F6H4, F6H6, F6H7, F6H8, F6H9, F6H10, F6H12, F8H8, F8H10, F8H12, F10H10, more preferably said linear SFA is selected from the group consisting of F4H4, F4H5, F4H6, F5H4, F5H5, F5H6, F5H7, F5H8, F6H2, F6H4, F6H6, F6H7, F6H8, F6H9, F6H10, F8H8, F8H10, F8H12, F10H10, even more preferably the linear SFA is selected from the group consisting of F4H4, F4H5, F4H6, F5H5, F5H6, F5H7, F5H8, F6H4, F6H6, F6H7, F6H8, F6H9, F6H10, F8H8, F8H10, F8H12, F10H10, most preferably the linear SFA is selected from the group consisting of F4H4, F4H5, F4H6, F5H5, F5H6, F5H7, F5H8, F6H6, F6H7, F6H8, F6H9, F6H10, F8H8, F8H10, F8H12, F10H10. In a further preferred embodiment, the linear SFA is selected from the group consisting of F4H5, F4H6, F5H6, F5H7, F6H6, F6H7, F6H8. In an even further preferred embodiment the linear SFA is selected from F4H5 and F6H8.

The liquid composition (2) to be administered by the method of the present invention may optionally comprise water. In a preferred embodiment, however, the liquid composition is water-free or at least substantially water-free. When comprising water the liquid composition may be an aqueous composition, typically comprising water up to approximately 99% by weight of the final composition or alternatively the liquid composition may be an emulsion, typically comprising up to approximately 90% by weight of the final composition, more typically approximately 0.01 to 80%, even more typically approximately 0.01 to 50%.

The liquid composition (2), preferably the substantially water-free solution comprising a liquid semifluorinated alkane or a mixture of two or more different semifluorinated alkanes to be administered usually has a density measured at 25° C. in the range of 0.7 to 1.9 g/cm³, preferably in the range of 1.0 and 1.7 g/cm³, more preferably in the range of 1.2 to 1.4 g/cm³. The viscosity of the liquid composition (2) measured at 25° C. versus air usually may be in the range of 0.3 to 5.2 mPa s, preferably in the range of 0.9 to 4.0 mPa s, more preferably in the range of 1.0 to 3.5 mPa s.

The surface tension of the liquid composition (2) versus air measured at 25° C. usually is in the range of 15 to 75 mN/m, preferably in the range of 15 to 30 mN/m, more preferably in the range of 15 to 23 mN/m.

Further, the composition utilized in the method of the present invention may comprise one or more active pharmaceutical ingredient (APIs) or alternatively may not comprise does or does not comprise an active pharmaceutical ingredient. Examples of liquid ophthalmic compositions are listed in Table 2.

According to the present invention a broad range of dropper configurations can be utilized when practicing the administration method according to the present invention (underpressure method). Examples of such droppers are listed in Table 1, with its dropper bottle configurations listed in Table 2. The dropper bottle (1) may comprise configurations of the dropper part (1A) and the bottle part (1B) as defined above.

In still a further embodiment of the first aspect of the invention, the administration method optionally further comprises the steps:

- i) inverting the drop dispenser or dropper bottle (1) as to return to an upright position, thereby sucking air from environment through the outflow channel (5) into the interior volume, as to effect underpressure relief in the dropper bottle (1);
- j) closing and storing the drop dispenser or dropper bottle (1);
- k) optionally repeating steps a) to j).

In a second aspect, the invention relates to the use of the method according to the first aspect of the invention for preventing or treating an ocular disease or any symptoms or conditions associated therewith.

The term "ocular disease" as used herein refers to a disease or a disorder of the eye, including disorders or diseases of the eyelid, lacrimal system, orbit, conjunctiva, sclera, cornea, iris, ciliary body, lens, choroid or retina, including disorders classified by WHO according to ICD codes H00-H06, H10-H13, H15-H22, H25-H28, H30-H36, H40-H42, H43-H45, H46-H48, H49-H52, H53-H54, H55-H59.

Generally, the administration of the ophthalmic composition (2) according to the method of the present invention may be carried out regularly, such as up to once per week, or up to once per day or up to 8, 7, 6, 5, 4, 3 or up to 2 times per day.

In a third aspect, the invention relates to a method of treating an ocular disease or any symptoms or conditions associated therewith comprising dropwise administration a liquid ophthalmic composition according to the method of the first aspect of the present invention.

In a fourth aspect, the present invention relates to a drop dispenser (1), comprising

- a container part (1B) with an interior volume partially filled with the liquid composition (2) and a gaseous phase (3) filling the remainder of the interior volume at ambient pressure, the container part (1B) having a displaceable section (1C) and optionally a substantially stationary section, and
- a dropper part (1A) in physical connection and in fluid communication with the interior volume of the container part (1B), comprising an outflow channel (5), connecting the interior volume of the container part (1B) to the environment; wherein at least a portion of the outflow channel (5) has an inner diameter in the range of 0.09 to 0.19 mm.

The drop dispenser (1) according to this aspect of the invention is particularly suitable and can preferably be adapted to be used in the administration method according to the first aspect of the invention. However, it should be understood the drop dispenser according to this aspect of the invention can also be used independently of the administration method according to the first aspect of the invention. Accordingly, as the drop dispenser provided in step a) of the present invention, it comprises a container part (1B) and a dropper part (1A) which are as described in connection with the first aspect of the invention.

15

The container part (1B) preferably also has a displaceable section (1C) and also holds a gaseous phase (3) which fills the remainder of the interior volume which is not filled with the liquid composition (2), whereas the terms displaceable section (1C), gaseous phase and liquid composition are also as defined in connection with the drop dispenser provided in the first aspect of the invention.

Furthermore, the drop dispenser of the present aspect of the invention has a dropper part (1A) as the one provided for in step a) of the present administration method. The "dropper part" is the portion of the drop dispenser through which the liquid composition (2) is discharged from the container part (1B) and subsequently administered. It is physically connected to the container part (1B) and connects the interior volume of the container part (1B) to the environment through an outflow channel (5) through which the liquid composition (2) to be administered is discharged. In this embodiment also, the outflow channel may optionally comprise a drop brake channel (6) which elongates the outflow channel further into the interior volume of the container part (1B).

The term "outflow channel (5)" as used in connection with this embodiment of the invention refers to a channel-like device that connects the interior volume of the dropper bottle (1) to the environment, safeguarding the fluid (or gaseous) communication between interior volume and the environment. Herein, the outflow channel (5) is delimited at its distal end by the duct opening (4) located inside the interior volume of the dropper bottle and by the dropper mouth (7) at its very proximal end located outside the interior volume of the dropper bottle. Upon administration, the liquid, preferably the liquid ophthalmic composition is delivered from interior volume through the outflow channel (5) to the dropper mouth (7), where the composition is released in a drop-by-drop manner.

The drop dispenser according to this aspect of the invention is characterized in that at least a portion of the outflow channel (5) has an inner diameter in the range of 0.09 to 0.19 mm, preferably in the range of from about 0.10 to about 0.18 mm, more preferably from about 0.11 to about 0.17 mm, even more preferably from about 0.12 to about 0.16 mm, yet more preferably from about 0.13 to about 0.16 mm or even from about 0.14 to about 0.16 mm and most preferably of about 0.15 mm. The term "at least a portion of" the outflow channel means that either the whole channel over its entire length has an inner diameter in the described range or that only a portion, part or fraction of the outflow channel has an inner diameter in the defined range or ranges. For example, about 75% or less, 60% or less, 50% or less or even 40%, 30% or even only 25% or less of the total length of the outflow channel (5) may have an inner diameter in the range as defined above. In other embodiments, only a small portion, such as only 20% or less or even only 10% or less of the total length of the outflow channel may have an inner diameter in the range as defined above.

In a preferred embodiment, the duct opening (4) of the outflow channel has an inner diameter in the range of 0.09 to 0.19 mm, preferably in the range of from about 0.10 to about 0.18 mm, more preferably from about 0.11 to about 0.17 mm, even more preferably from about 0.12 to about 0.16 mm, yet more preferably from about 0.13 to about 0.16 mm or even from about 0.14 to about 0.16 mm and most preferably of about 0.15 mm. In yet further embodiments, the duct opening (4) and a portion of the outflow channel (5) beginning at the duct opening have an inner diameter in the range of 0.09 to 0.19 mm.

16

In this aspect of the invention also, the outflow channel (5) may have different cross-sectional shapes, such as circular, elliptic, rectangular or quadratic or the like, however, it is preferably a circular channel. In cases in which the duct channel does not have a circular cross-sectional shape the term "inner diameter" is to be understood as the largest diameter of such particular shape. Preferably, the outflow channel (5) has different diameters at its distal end (duct opening (4)) and at its proximal end (dropper mouth (7)). In one embodiment, the diameter at the distal end (duct opening (4)) is smaller than the diameter at the proximal end (dropper mouth (7)). In this embodiment, the outflow channel is narrowing from the proximal dropper mouth (7) to the distal duct opening (4). In still a further embodiment, the diameter at the distal end (duct opening (4)) is larger than the diameter at the proximal end (dropper mouth (7)).

The term "duct opening (4)" of the dropper bottle as used herein refers to the most distal end of the outflow channel (5). Accordingly, the duct opening (4) is preferably circular and/or has a preferred diameter which may also be in the range of from 0.09 to 0.19 mm or, in cases in which the portion of the outflow channel (5) having an inner diameter of 0.09 to 0.19 mm does not comprise the duct opening (4), preferably the inner diameter of the duct opening (4) is in the range of from 0.2 to 0.5 mm, more preferably its diameter is in the range of from 0.2 to 0.3 mm.

The term "dropper mouth" (7) as used in this embodiment refers to the most proximal end of the outflow channel (5), where the drops to be released are formed. The diameter of the dropper mouth (7) is preferably circular and/or its diameter is preferably in the range of 1 to 5 mm, preferably its diameter is in the range of 2 to 3 mm, more preferably its diameter is in the range of 2.0 to 2.6 mm, even more preferably its diameter is in the range of about 2.0 to 2.4 mm.

In a particularly preferred embodiment, the duct opening (4) of the outflow channel has an inner diameter of about 0.15 mm and the diameter of the dropper mouth (7) is about 2.0 to 2.4 mm, preferably about 2.4 mm. In yet a further particularly preferred embodiment the duct opening (4) of the outflow channel has an inner diameter of about 0.15 mm and the inner diameter of the rest of the outflow channel including the dropper mouth (7) is about 2.0 to 2.4 mm, preferably about 2.4 mm. In both embodiments, the duct opening (4), the outflow channel (5) and/or the dropper mouth (7) preferably has a circular cross-sectional shape.

According to this aspect of the invention also, it is to be understood that the optional drop brake channel (6), if present, does not form part of the outflow channel (5) which extends from the duct opening (4) and therefore does not contribute to the total length of the outflow channel (5).

One advantage of the reduced diameter of at least a portion of the outflow channel of the drop dispenser according to the present aspect of the invention is that the undesired spontaneous outflow or drop-formation of the liquid composition, preferably the liquid ophthalmic composition can be reduced significantly for aqueous as well as non-aqueous compositions. Especially in cases of non-aqueous compositions, especially for SFA-containing compositions this has been found to be particularly beneficial.

It has been found that for practical purposes a range of 0.09 to 0.19 mm of at least a portion of the outflow channel is preferable as it combines significantly reduced spontaneous outflow with acceptable forces necessary to press the liquid composition through the outflow channel (5). Particularly in view of a possible use of the disclosed drop dispenser (1) characterized by least a portion of the outflow channel (5) having an inner diameter in the range of 0.09 to

17

0.19 mm in an administration method according to the first aspect of the invention this has been shown of considerable importance for e.g. elderly or disabled users.

Furthermore, it has been found that the drop dispenser according to the present aspect of the invention offers higher precision and reproducibility of the drop sizes and volumes to be dispensed, independent of the temperature of the drop dispenser, liquid composition and/or the environment as well as the actual filling level of the drop dispenser or "headspace" above the liquid composition in the drop dispenser.

The outflow channel (5) with at least a portion having an inner diameter in the range of 0.09 to 0.19 mm according to this aspect of the invention can be produced by standard techniques, such as laser drilling or welding.

In a fifth aspect, the present invention relates to a kit comprising

a drop dispenser (1) at least partially filled with a liquid composition (2) and a gaseous phase (3) for the use in a method according to the first aspect of the invention and

directions for use of the drop dispenser (1) in a method according to the first aspect of the invention.

The directions or instructions for use comprised by the kit according to this aspect of the invention may be in any form suited to instruct the user how to perform the topical administration method according to first aspect of the invention (underpressure method). It may be in any readable or tangible form, preferably in printed form or in any machine- or computer-readable form preferably in form of a machine-readable optical label such as, for example, a barcode or a QR-code. In a particularly preferred embodiment the directions for use are provided in form of an instruction leaflet, product or package insert or as an enclosed label. Preferably the directions or instructions for use are provided in printed form, for example in form of a printed label, which may be provided together with the drop dispenser (1) or dropper bottle (1) to be used according to the method of the first aspect of the invention. For example, such a label may be packaged together with the said drop dispenser (1) or dropper bottle (1).

In summary, the present invention comprises the following numbered items:

1. A method for dropwise topical administration of a liquid composition (2), comprising the steps of:
 - a) providing a drop dispenser (1), comprising
 - a container part (1B) with an interior volume partially filled with the liquid composition (2) and a gaseous phase (3) filling the remainder of the interior volume at ambient pressure, the container part (1B) having a displaceable section (1C) and optionally a substantially stationary section, and
 - a dropper part (1A) in physical connection and in fluid communication with the interior volume of the container part (1B), comprising an outflow channel (5), connecting the interior volume of the container part (1B) to the environment;
 - b) exerting a first force to the displaceable section (1C) of the container part (1B) of the drop dispenser (1) while holding the drop dispenser (1) in an upright position in which the outflow channel (5) is not in contact with the liquid composition (2), thereby reducing the interior volume of the container part (1B) and forcing the gaseous phase (3) of the interior volume at least partially out of the drop dispenser (1) into the environment;

18

- c) inverting the drop dispenser (1) to an inverted position in which the liquid composition (2) is in contact with the outflow channel (5);
 - d) releasing said first force from the displaceable section (1C) of the container part (1B) at least partly, thereby reducing the pressure inside the container part (1B) below ambient pressure; and
 - e) exerting a second force to the displaceable section (1C) of the container part (1B), while still holding the drop dispenser in the inverted position in which the liquid composition (2) is in contact with the outflow channel (5), thereby raising the pressure inside the interior volume of the container part (1B) above ambient pressure and releasing the liquid composition (2) dropwise from the dropper part (1A) of the drop dispenser (1).
2. The method according to item 1, wherein the inversion of the drop dispenser (1) to the inverted position according to step (c) and the release of the first force according to step (d) is performed at least partly simultaneously.
3. The method according to any of the preceding items, wherein the liquid composition comprises a liquid semi-fluorinated alkane.
4. The method according to any of the preceding items, wherein the liquid composition is a water-containing or a water-free composition.
5. The method according to any of the preceding items, wherein the outflow channel is narrowing from the proximal dropper mouth (7) to the distal duct opening (4).
6. The method according to any of the preceding items, wherein the drops to be released are formed at the dropper mouth (7) at the proximal end of the outflow channel (5).
7. The method according to any of the preceding items, wherein the exerting a pressuring force is by manually compressing (squeezing) the displaceable part or deformable wall part (1C).
8. The method according to any of the preceding items, wherein the drop dispenser or dropper bottle in step (e) is tilted in the inverted position during the dropwise release of the composition, preferably the drop dispenser or dropper bottle is tilted up to 90° in the inverted position, more preferably the drop dispenser or dropper bottle is tilted up to 45° in the inverted position, wherein the angle is measured between the normal axis of the drop dispenser or dropper bottle and a perpendicular reference line.
9. The method according to any of the preceding items, wherein air is sucked in from the environment through the outflow channel (5) into the interior volume of the container or bottle part (1B), when said first pressuring force is released.
10. The method according to any of the preceding items, wherein the underpressure in the interior volume of the dropper bottle (1) prevents unintentional and/or uncontrolled release of liquid composition (2) from the dropper mouth (7) through the outflow channel (5).
11. The method according to any of the preceding items, wherein the dropper part (1A) comprises a drop brake channel (6), preferably with a circular cross section, extending the outflow-channel (5) from the duct opening (4) into the interior volume of the container or bottle part (1B).
12. The method according to any of the preceding items, wherein the duct opening (4) is preferably circular and/or has a preferred diameter in the range of from 0.15 to 1.2 mm, more preferably in the range of from 0.18 to 0.5 mm, and even more preferably in the range of from 0.2 to 0.3 mm.

13. The method according to any of the preceding items, wherein the diameter of the dropper mouth (7) is between 1 and 5 mm, preferably its diameter is between 2 and 3 mm, more preferably its diameter is between 2.0 and 2.6 mm, even more preferably its diameter is about 2.0 to 2.4 mm.
14. The method according to any of the preceding items, wherein the diameter of the dropper brake channel (6) is larger than the diameter of the duct opening (4).
15. The method according to any of the preceding items, wherein the dropper part (1A) and the container part or bottle part (1B) are manufactured from plastic material, preferably from polypropylene or polyethylene.
16. The method according to any of the preceding items, wherein the bottle part (1B) is manufactured with the deformable wall part (1C) being manually deformable, preferably the deformable wall part (1C) having a wall thickness of between 0.4 and 1.6 mm, preferably having a wall thickness of between 0.5 and 1.0 mm, more preferably having a wall thickness of between 0.6 and 0.8 mm.
17. The method according to any of the preceding items, wherein the gaseous phase (3) comprises air and/or an inert gas, such as nitrogen or argon.
18. The method according to any of the preceding items, wherein the liquid composition (2) is characterized by a density measured at 25° C. in the range of 0.7 to 1.9 g/cm³, preferably in the range of 1.0 and 1.7 g/cm³, more preferably in the range of 1.2 to 1.4 g/cm³.
19. The method according to any of the preceding items, wherein the composition is characterized by a viscosity measured at 25° C. versus air in the range be in the range of 0.3 to 5.2 mPa s, preferably in the range of 0.9 to 4.0 mPa s, more preferably in the range of 1.0 to 3.5 mPa s.
20. The method according to any of the preceding items, wherein the composition is characterized by a surface tension versus air measured at 25° C. is in the range of 15 to 75 mN/m, preferably in the range of 15 to 30 mN/m, more preferably in the range of 15 to 23 mN/m.
21. The method according to any of the preceding items, wherein the liquid composition (2) comprises a liquid linear or branched semifluorinated alkane composed of one perfluorinated segment and one non-fluorinated hydrocarbon segment, preferably each segment independently having carbon atoms selected from the range of 4 to 10.
22. The method according to any of the preceding items, wherein the semifluorinated alkane is a liquid of the formula $F(CF_2)_n(CH_2)_mH$ wherein n and m are integers independently selected from the range of 4 to 10.
23. The method according any of the preceding items, wherein the semifluorinated alkane is a liquid selected from the group consisting of F4H4, F4H5, F4H6, F4H7, F4H8, F5H4, F5H5, F5H6, F5H7, F5H8, F6H2, F6H4, F6H6, F6H7, F6H8, F6H9, F6H10, F6H12, F8H8, F8H10, F8H12, F10H10, more preferably said linear SFA is selected from the group consisting of F4H5, F4H6, F5H6, F5H7, F6H6, F6H7, F6H8 most preferably the semifluorinated alkane is selected from F4H5 and F6H8.
24. The method according to any of the preceding items, wherein the composition is in form of a solution or a suspension or in form of an emulsion.
25. The method according to any of the preceding items, wherein the liquid composition does or does not comprise a pharmaceutical active ingredient.

26. The method according to any of the preceding items, wherein the composition further comprises one or more excipients.
27. The method according to any of the preceding items, further comprising the step: f) dropwise administering the composition to the eye, preferably to the eye lid, eye sac or an ophthalmic tissue of a subject in need thereof.
28. The method according to item 27, wherein the administering of the ophthalmic composition (2) is carried out up to once per week, or up to once per day or up to 8, 7, 6, 5, 4, 3 or up to 2 times per day.
29. The method according to any of the preceding items, further comprising the steps:
- g) releasing the second pressuring force from the displaceable part (1C) of the container or bottle part (1B), while still holding the drop dispenser or dropper bottle respectively in the inverted position, thereby stopping the release of the liquid composition (2), and
 - h) optionally exerting one or more further pressuring force(s) to the displaceable or deformable wall part (1C) of the container or bottle part (1B), while still holding the drop dispenser or dropper bottle in an inverted position, thereby releasing further liquid composition (2) in a dropwise manner from the dropper part (1A) and subsequently releasing the one or more further pressuring force(s) from the displaceable part (1C) of the container or bottle part (1B).
30. The method according to item 29, further comprising the steps:
- i) inverting the drop dispenser or dropper bottle (1) as to return to an upright position, thereby sucking air from environment through the outflow channel (5) into the interior volume, as to effect underpressure relief in the dropper bottle (1);
 - j) closing and storing the drop dispenser or dropper bottle (1);
 - k) optionally repeating steps a) to j).
31. The method according to any of the preceding items, wherein the drop dispenser (1), comprises
- a container part (1B) with an interior volume partially filled with the liquid composition (2) and a gaseous phase (3) filling the remainder of the interior volume at ambient pressure, the container part (1B) having a displaceable section (1C) and optionally a substantially stationary section, and
 - a dropper part (1A) in physical connection and in fluid communication with the interior volume of the container part (1B), comprising an outflow channel (5), connecting the interior volume of the container part (1B) to the environment; wherein at least a portion of the outflow channel (5) has an inner diameter in the range of 0.09 to 0.19 mm.
32. Use of a method according to any of the preceding items for preventing or treating an ocular disease or any symptoms or conditions associated therewith.
33. Method of treating an ocular disease or disorder or any symptoms or conditions associated therewith, comprising dropwise administration of a liquid ophthalmic composition according to the method of any of the preceding items.
34. A drop dispenser (1), comprising
- a container part (1B) with an interior volume partially filled with the liquid composition (2) and a gaseous phase (3) filling the remainder of the interior volume at ambient pressure, the container part (1B) having a displaceable section (1C) and optionally a substantially stationary section, and

21

- a dropper part (1A) in physical connection and in fluid communication with the interior volume of the container part (1B), comprising an outflow channel (5), connecting the interior volume of the container part (1B) to the environment; wherein at least a portion of the outflow channel (5) has an inner diameter in the range of 0.09 to 0.19 mm.
35. A kit comprising
- a drop dispenser (1) at least partially filled with a liquid composition (2) and a gaseous phase (3) for the use in a method according to the method of any of items 1 to 30 and
 - directions for use of the drop dispenser (1) in a method according to the method of any of items 1 to 30.
36. The kit according to item 34, wherein the directions for use are provided in form of an instruction leaflet, product or package insert or as an enclosed label.

DESCRIPTION OF THE DRAWINGS

List of Reference Numerals

- 1 drop dispenser or dropper bottle
- 1A dropper part of the drop dispenser or dropper bottle
- 1B container part of the drop dispenser or bottle part of the dropper bottle
- 1C displaceable section of the container part or dropper bottle
- 2 liquid composition
- 3 gaseous phase
- 4 duct opening of the outflow channel
- 5 outflow channel
- 6 drop brake channel
- 7 dropper mouth of the outflow channel

FIG. 1(A) shows a schematic representation of a drop dispenser (1) or a dropper bottle (1) in the upright position with the dropper mouth (7) facing upwards. The drop dispenser or dropper bottle (1) comprises a container or bottle part (1B) and a dropper part (1A). The container part or bottle part (1B) comprises an interior volume that is at least partially filled with the liquid ophthalmic composition (2). The remainder of the interior volume of the container or bottle part (1B) is filled with a gaseous phase (3). The wall of the container or bottle part has a displaceable section (1C) to allow a pressuring force to compress the interior volume (e.g. by manual squeezing). The dropper part (1A) is mounted onto the container or bottle part (1B), connecting the interior volume of the bottle part (1B) via the optional drop brake channel (6) and via the outflow channel (5) with the environment. Herein, the fluid communication of the interior volume of the container or bottle part (1B) to the environment is effected in sequential order (from distal to proximal end) by the optional drop brake channel (6) and the outflow channel (5). The outflow channel (5) is delimited by the duct opening (4) at the distal end and by the dropper mouth (7) at the proximal end. In this upright position the liquid composition (2) does not contact the neither the outflow channel (5) nor the optional drop brake channel (6).

FIG. 1(B) is a schematic representation of the dropper part (1A) of the drop dispenser or dropper bottle (1), showing the diameter positions of the optional dropper brake channel (6), of the duct opening (4) and of the dropper mouth (7).

FIG. 2(A) shows a schematic representation of a slightly different configuration of the drop dispenser or dropper bottle (1) in the upright position (with the dropper mouth (7) facing upwards) comprising a bottle or container part (1B) and a dropper part (1A). The bottle part (1B) comprises an

22

interior volume that is at least partially filled with the liquid ophthalmic composition (2) and the remainder of the interior volume of the bottle part (1B) is filled with a gaseous phase (3). The wall of the bottle part (1C) is deformable as to allow a pressuring force to compress the interior volume (e.g. by manual squeezing). The dropper part (1A) is mounted onto the bottle part (1B), connecting the interior volume of the bottle part (1B) via the optional drop brake channel (6) and, via the outflow channel, (5) with the environment. Herein, the fluid communication of the interior volume of the bottle part (1B) to the environment is effected in sequential order (from distal to proximal end) by the optional drop brake channel (6) and the outflow channel (5). The outflow channel (5) is delimited by the duct opening (4) at the distal end and by the dropper mouth (7) at the proximal end. In contrast to the schematic representation of FIG. 1 the diameter of the outflow channel (5) is not increasing continuously in direction from the duct opening (4) to the dropper mouth (7) of the outflow channel.

FIG. 2(B) shows an enlarged schematic representation of the modified dropper part (1A) according to FIG. 2(A), showing the diameter positions of the optional dropper brake channel (6), of the duct opening (4) and of the dropper mouth (7).

FIG. 3(A) shows a schematic representation of the drop dispenser or dropper bottle (1) in the inverted position (with the dropper mouth (7) facing downwards) when a conventional method (e.g. pressure method or inversion method) known from administration of water-based ophthalmic compositions is applied for the administration of an ophthalmic compositions comprising a SFAs: As can be seen the outflow channel (5) is filled with the SFA-comprising ophthalmic composition and the liquid composition (2) is unintentionally (uncontrolled) released from the dropper mouth (7) in a dropwise or non-dropwise fashion. This usually is the case when applying the known pressure method or the known inversion method without exerting a pressuring force to the deformable wall part of the dropper bottle (1C) while the dropper bottle (1) is (still) in the upright position.

FIG. 3(B) shows a schematic representation of the dropper bottle (1) in the inverted position when the method according to the first aspect of the present invention (underpressure method) is applied for administration of an ophthalmic composition comprising SFAs: Thereby, the underpressure in the interior volume of the dropper bottle (1) prevents uncontrolled and unintentional release of liquid composition (2) from the dropper mouth (7) through the outflow channel (5). Only when a second pressuring force is exerted to the deformable wall part (1C) of the dropper bottle drops of the liquid composition (2) comprising an SFA are released in controlled manner from the drop dispenser (1). According to the present invention, the underpressure generated in the interior volume (mainly in the gaseous phase (3) of the bottle part (1B) warrants that uncontrolled (unintentional) release of drops of compositions comprising SFAs is prevented effectively.

FIG. 4 is a schematic representation of the administration method of the present invention (underpressure method) comprising sequentially the steps a) to e) as described above:

FIG. 4(A) schematically shows the starting position with the dropper bottle (1) in the upright position, with no underpressure present in the interior volume of the bottle part (1B), the dropper mouth (7) pointing upwards.

In FIG. 4(B) a first pressurizing force is exerted to the deformable wall part of the bottle (1C) (said exerting of a pressuring force depicted as arrows pointing towards the

deformable wall part). By doing so, the interior volume of the bottle part (1B) is compressed, thereby forcing the gaseous phase (3) at least partially out of the dropper bottle (1) through the optional drop brake channel (6) and the outflow channel (5).

In FIG. 4(C) the first pressuring force still exerted to the deformable wall part (1C), the dropper bottle (1) is inverted into an inverted position with the dropper mouth (7) pointing downwards and with the liquid composition contacting the outflow channel (5) and the optional drop brake channel (6), optionally partially filling the outflow channel (5) with the liquid ophthalmic composition (2).

In FIG. 4(D) the dropper bottle (1) is still in the inverted position and by releasing the first pressuring force from the deformable wall part (1C) (said release of the pressuring force depicted as arrows pointing away from the deformable wall part), air is sucked from the environment into the interior volume of the dropper bottle. The air and optionally the liquid composition (2) already in the outflow channel (5) sequentially flows through the outflow channel (5), and the optional drop brake channel (6) by force of the underpressure generated in the interior volume of the bottle part (1B).

FIG. 4(E) shows the situation in which by exerting a second pressuring force to the deformable wall part (1C) of the bottle part (1B) (said exerting of a pressuring force depicted as arrows pointing towards the deformable wall part), with the dropper bottle (1) still in the inverted (downside) position, the ophthalmic composition (2) is released from the dropper bottle (1) in a controlled dropwise manner. Upon release, the liquid ophthalmic composition (2) originating from the interior volume is sequentially flowing through the optional dropper brake channel (6) and the outflow channel (5), with the drops of the liquid composition to be released forming at the proximal end of the outflow channel (5), namely at the circular dropper mouth (7).

FIG. 5 is a schematic representation of an embodiment of the administration method of the present invention (underpressure method), wherein the inverting of the dropper bottle (1) into the inverted position (FIG. 3C) and the release of the pressuring force (FIG. 3D) is performed simultaneously. Thus, this embodiment of the present invention comprising sequentially the steps a) to e), wherein steps c) and d) are performed simultaneously:

FIG. 5(A) shows the starting position according to step a) of the method of the present invention. The dropper bottle (1) in the upright position, with no underpressure present in the interior volume of the bottle part (1B), the dropper mouth (7) pointing upwards.

FIG. 5(B) shows the situation in which a first pressurizing force is exerted to the deformable wall part of the bottle (1C) (said exerting of a pressuring force depicted as arrows pointing towards the deformable wall part). By doing so, the interior volume of the bottle part (1B) is reduced, thereby forcing the gaseous phase (3) at least partially out of the dropper bottle (1) into the environment, thereby sequentially flowing through the optional drop brake channel (6) and the outflow channel (5).

In FIG. 5(D) the dropper bottle (1) is shown in the inverted position after inversion and simultaneous release of said first pressuring force (said release of a pressuring force depicted as arrows pointing away from the deformable wall part), with the dropper mouth (7) pointing downwards and the liquid composition contacting the flow channel (5) and the optional drop brake channel (6). Air (and optionally the liquid composition (2) already in the outflow channel (5)) is sucked from the environment into the interior volume of the dropper bottle (1), by sequentially flowing through the

outflow channel (5) and the optional drop brake channel (6), by force of the underpressure generated in the interior volume of the bottle part (1B).

FIG. 5(E) shows the situation in which by exerting a second pressuring force to the deformable wall part (1C) of the bottle part (1B) (said exerting of a pressuring force depicted as arrows pointing towards the deformable wall part), with the dropper bottle (1) still in the inverted position, the ophthalmic composition (2) is released from the dropper bottle (1) in a controlled drop-by-drop manner. Upon release, the liquid ophthalmic composition (2) originating from the interior volume is sequentially flowing through the optional dropper brake channel (6) and the outflow channel (5), with the drops forming at the proximal end of the outflow channel (5), namely at the (circular) dropper mouth (7).

FIG. 6 is a schematic representation of alternative embodiments in which the drop dispenser or dropper bottle (1) is in the inverted position allowing controlled dropwise release of liquid ophthalmic compositions according to the administration method of the present invention.

In FIG. 6(A) a situation is shown in which by exerting a second pressuring force to the deformable wall part (1C) of the bottle part (1B) (said exerting of a pressuring force depicted as arrows pointing towards the deformable wall part), with the dropper bottle (1) in a fully inverted position the ophthalmic composition is released from the dropper bottle (1) in a controlled dropwise manner. (with the dropper mouth (7) pointing downwards and with the central axis of the dropper bottle (depicted as dashed line) being in an about perpendicular position and with the liquid composition (2) contacting the outflow channel (5).

FIG. 6 (b) shows a situation in which, by exerting a second pressuring force to the deformable wall part (1C) of the bottle part (1B) (said exerting of a pressuring force depicted as arrows pointing towards the deformable wall part), with the dropper bottle (1) in a tilted inverted position the ophthalmic composition is released from the dropper bottle in a controlled dropwise manner (with the dropper mouth (7) pointing downwards and with the central axis of the dropper bottle (depicted as dashed line) being in an about 45 to 90° angle in relation to the perpendicular position).

It is understood that according to the present invention the release of the liquid ophthalmic composition in a dropwise manner may be performed not only at said 2 exemplary positions depicted in FIG. 6(A) or 6(B), but also at all intermediate positions, namely at an angle of between 0° and up to 90° compared to a perpendicular axis.

FIG. 7 shows a schematic representation of a dropper bottle (1) comprising a bottle part (1B) and a dropper part (1A).

In FIG. 7(A) an exemplary bottle part (1B) is shown, comprising an interior volume that is at least partially filled with the liquid ophthalmic composition (2) and a gaseous phase (3) filling the remainder of the interior volume of the bottle part (1B). The wall of the bottle part is deformable (1C) as to allow a pressuring force (e.g. manual squeezing) to compress the interior volume.

FIG. 7(B) shows an exemplary dropper part (1A) comprising sequentially from its distal to its proximal end a drop brake channel (6) and an outflow channel (5), being in fluid communication with each other, with the outflow channel (5) being delimited at its distal end by the duct opening (4) and by the dropper mouth (7) at its proximal end.

FIG. 7(C) shows an exemplary dropper bottle (1) comprising said dropper part (1A) mounted onto the bottle part (1B).

25

FIG. 8 shows another exemplary dropper part (1A) comprising sequentially from its distal to its proximal end a drop brake channel (6) and an outflow channel (5), being in fluid communication with each other, with the outflow channel (5) being delimited at its distal end by the duct opening (4) and by the dropper mouth (7) at its proximal end. In this particular embodiment, the duct opening (4) has a small inner diameter of, e.g. 0.15 mm and the outflow channel has a larger inner diameter which is increasing towards the dropper mouth (7), i.e. the proximal end of the outflow channel (5) to a diameter e.g. in the range of 2.0 to 2.4 mm.

The following examples serve to illustrate the present invention without, however, limiting it in any respect:

EXAMPLES

Example 1: NovaTears® Ophthalmic Composition

The liquid NovaTears® (Novaliq GmbH, Germany) ophthalmic composition for treating dry eye disease, comprises 1-Perfluorohexyloctane (F6H8) and is provided in a dropper bottle (1) with a polyethylene dropper part (1A) mounted to a polypropylene bottle part (1B) for holding 3 ml of NovaTears®. The dropper part (1A) comprises an outflow channel (5) with a dropper mouth (7) (diameter 2.4 mm) at its proximal end and a duct opening (4) (0.3 mm diameter) at its distal end. The dropper part (1A) further comprises a dropper brake channel (6) which extends the outflow-channel (5) from the duct opening (4) into the interior volume of the bottle part (1B). The outflow channel (5) and the dropper brake channel (6) are in fluid communication with the interior volume of the bottle part (1B), allowing—upon inverting of the dropper bottle (1)—the liquid ophthalmic composition to flow from the interior volume to the proximal end of the outflow channel (5). Herein, the liquid first fills the optional drop brake channel (6), before it enters into the outflow channel (5) at the duct opening (4) and continues to the dropper mouth (7), where it is released as a drop.

Example 2: Administration of a SFA-Comprising Ophthalmic Composition (NovaTears®) Employing the Inversion Method

After opening the dropper bottle (1), the subjects head is slightly tilted back, while looking upward. The lower eyelid is gently pulled downward, before the dropper bottle (1) is positioned with the dropper part (1A) above the lower eyelid. The dropper bottle is then inverted with the dropper mouth (7) facing to the eye of the subject. By doing so, drops are instantly released in an uncontrolled manner from the dropper mouth (7). Dropping starts unintentionally with drops being released in medium frequency. Dropping of the bottle can only be stopped by reverting the bottle back to the starting position.

Example 3: Administration of a SFA-Comprising Ophthalmic Composition (NovaTears®) Employing the Pressure Method

After opening the dropper bottle (1), the subjects head is slightly tilted back, while looking upward. The lower eyelid is gently pulled downward, before the dropper bottle (1) is positioned with the dropper part (1A) above the lower eyelid. The dropper bottle (1) is then inverted with the dropper mouth (7) facing to the eye of the subject and then the deformable wall part (1C) of the bottle part (1B) is slightly squeezed by hand. By doing so, drops are instantly

26

released in an uncontrolled manner from the dropper mouth (7). Dropping starts unintentionally with drops being released in high frequency. Dropping of the bottle can only be stopped by releasing the pressure force and reverting the bottle back to the starting position.

Example 4: Administration of a SFA-Comprising Ophthalmic Composition (NovaTears®) Employing the Method of the Present Invention (Underpressure Method)

After opening the dropper bottle (1), the subjects head is slightly tilted back, while looking upward your head back and look upward. The lower eyelid is gently pulled downward, before the dropper bottle (1) is positioned with the dropper part (1A) above the lower eyelid. While still in the upright position the deformable wall part (1C) of the bottle part (1B) of the dropper bottle (1) is slightly squeezed to force some of the gaseous volume in the headspace of the bottle part (1B) out of the dropper bottle (1). Then, the dropper bottle (1) is inverted (with the dropper mouth (7) facing down to the eye) and simultaneously the pressure is released from the deformable wall part (1C), thereby generating an underpressure inside the interior volume of the dropper bottle (1). Concomitantly, air from the environment is sucked through the outflow channel (5) into the interior volume. The underpressure generated prevents unintentional or uncontrolled release of drops from the dropper bottle (1). The controlled release of the composition in a drop-by-drop manner is initiated only when a second pressuring force is applied to the deformable wall part (1C). Hereby, the number of drops to be released is easily controlled by the second pressuring force. The dropping can be easily stopped by release of said second pressuring force and re-initiated by re-applying one or more further pressuring forces to the deformable wall part (1B) of the dropper bottle (1). Following the steps above, the NovaTears® ophthalmic composition is administered reliably to patients suffering from dry eye disease (keratoconjunctivitis sicca).

Example 5: Administration of an Ophthalmic Composition Comprising a SFA and an Active Pharmaceutical Ingredient Employing the Method of the Present Invention (Underpressure Method)

The liquid ophthalmic composition for treating dry eye disease, comprising 1 mg/ml Ciclosporine A, dissolved in 1 wt-% ethanol in 1-Perfluorobutyl-pentane (F4H5) is provided in a dropper bottle (1) with a polyethylene dropper part (1A) mounted to a polypropylene bottle part (1B).

Said cyclosporine-containing ophthalmic SFA-based-composition (3) is administered as described in Example 4. Herein, the underpressure generated prevents unintentional or uncontrolled release of drops of the pharmaceutical composition from the dropper bottle (1). The controlled release of the composition in a drop-by-drop manner is initiated only when a second pressuring force is applied to the deformable wall part (1C). Hereby, the number of drops to be released is easily controlled by said second pressuring force. The dropping of the pharmaceutical composition can be easily stopped by release of said second pressuring force and re-initiated by re-applying one or more further pressuring forces to the deformable wall part (1B) of the dropper bottle (1). Following the steps above, the ciclosporine-containing ophthalmic composition is administered reliably to patients suffering from dry eye disease (keratoconjunctivitis sicca).

Example 6: Parallel Testing of Different Liquid Ophthalmic Compositions and Dropper Bottles

In the following, the administration method of the present invention (underpressure method) is compared to the inversion method. Herein, different liquid ophthalmic compositions and different dropper bottle configurations were tested when using either the underpressure method or the inversion method

Experimental Procedure for the Underpressure Method (According to the Present Invention):

A dropper bottle (1) as listed in Table 1 below was provided and filled with a liquid ophthalmic composition as identified in Table 2. Then the sidewalls as the deformable wall part (1C) of the dropper bottle (1) were slightly squeezed to force the gaseous phase (3) partially out of the dropper bottle (1). Afterwards, the bottles were inverted manually to an inverted position. During or after inversion of the dropper bottles the squeezing was stopped and the pressuring force was released, concomitantly generating underpressure in the inner volume of the dropper bottle (1). Finally, the inverted drop bottles were mounted on a suitable bottle holder at a fixed inclination versus the perpendicular axis. During a period of 30 seconds it was observed if drops are unintentionally released in an uncontrolled fashion without applying a second pressuring force to the deformable wall part of the bottle and the number of drops released were recorded.

Experimental Procedure for the Inversion Method (not According to the Present Invention):

A dropper bottle (1) as listed in Table 1 below was provided and filled with a liquid ophthalmic composition as identified in Table 2. Then the dropper bottles were inverted manually to an inverted position. Finally, the inverted drop bottles were mounted on a suitable bottle holder at a fixed inclination versus the perpendicular axis. During a period of 30 seconds it was observed if drops are unintentionally

released in an uncontrolled fashion without applying a second pressuring force to the deformable wall part of the bottle and the number of drops released were recorded. Table 1: Dropper bottle configurations as employed in Example 6:

dropper type	dropper, manu- facturer	bottle part (1B)	dropper part (1A)	diameter		dropper brake channel (6)
				mouth opening (7)/mm	duct opening (4)/mm	
1	Packsys GmbH	polypropylene	polyethylene	2.4	0.3	yes
2	Packsys GmbH	polyethylene	polyethylene	2.4	0.3	yes
3	Packsys GmbH	polypropylene	polyethylene	2.4	0.8	no
4	Packsys GmbH	polypropylene	polyethylene	2.4	1.2	no
5	Packsys GmbH	polypropylene	polyethylene	2.4	0.2	yes
6	Systane ® dropper	n.d.	n.d.	n.d.	n.d.	yes
7	Artelac ® dropper (Bausch + Lomb)	n.d.	n.d.	n.d.	n.d.	yes
8	Refresh ® by Artelac ® dropper	n.d.	n.d.	n.d.	n.d.	yes
9	Thealoz ® Abak*	n.d.	n.d.	n.d.	n.d.	n.d.
10	Nemera Novelia ®**	n.d.	n.d.	n.d.	n.d.	n.d.

TABLE 2

Solvent	Formulation type	API, excipients	dropper type	duct opening diameter/mm	release of first pressuring force	dropping angle	inversion method successful	underpressure method successful
F6H8	solution	n.a.	1	0.3	after inversion	0°	no	yes
F6H8	solution	n.a.	1	0.3	after inversion	tilted (45°)	no	yes
F4H5	solution	n.a.	1	0.3	after inverting	0°	no	yes
F4H5	solution	n.a.	1	0.3	after inversion	tilted (45°)	no	yes
F4H5	solution	cyclosporin (0.1% w/v), ethanol (1% w/w)	1	0.3	after inversion	0°	no	yes
F4H5	solution	cyclosporin (0.1% w/v), ethanol (1% w/w)	1	0.3	after inversion	tilted (45°)	no	yes
F6H8	solution	n.a.	1	0.3	during inversion	0°	no	yes
F6H8	solution	n.a.	1	0.3	during inversion	tilted (45°)	no	yes
F6H8	solution	n.a.	2	0.3	during inversion	0°	no	yes
F6H8	solution	n.a.	2	0.3	during inversion	tilted (45°)	no	yes
F6H8	solution	n.a.	2	0.3	during inversion	tilted (45°)	no	yes
F4H5	solution	n.a.	3	0.8	during inversion	0°	no	yes
F4H5	solution	n.a.	4	1.2	during inversion	0°	no	yes

TABLE 2-continued

Solvent	Formulation type	API, excipients	dropper type	duct opening diameter/mm	release of first pressuring force	dropping angle	inversion method successful	underpressure method successful
water	solution	n.a.	4	1.2	during inversion	0°	(yes)	yes
F4H5	suspension	sucrose (0.025% w/w)	1	0.3	during inversion	0°	n.a.	yes
ethanol	solution	n.a.	5	0.2	during inversion	0°	(yes)	yes
F4H5	solution	cyclosporin (0.1 % w/v), ethanol (1% w/w)	5	0.2	during inversion	0°	no	yes
water	solution	Systane® (commercial eye drops)	6	n.a.	during inversion	0°	(yes)	yes
water	solution	Artelac® (commercial eye drops)	7	n.a.	during inversion	0°	no	yes
F4H5	solution	n.a.	6	n.a.	during inversion	0°	no	yes
F4H5	solution	n.a.	7	n.a.	during inversion	0°	no	yes
Propyl-ethylen-glycol water	solution		5	0.2	during inversion	0°	no	no
	solution	Refresh® (commercial eye drops)	8	n.a.	during inversion	0°	no	yes
F6H8	solution	n.a.	8	n.a.	during inversion	0°	no	yes
water	solution	Thealoz® Duo (commercial eye drops)	9	n.a.	during inversion	0°	yes	yes
water	solution	Thealoz® Duo (commercial eye drops)	9	n.a.	after inversion	0°	yes	yes
F4H5	solution	n.a.	10	n.a.	during inversion	0°	yes	yes
F4H5	solution	n.a.	10	n.a.	after inversion	0°	yes	yes
F4H5	solution	n.a.	1	0.3	during inversion	0°	no	yes
F4H5	solution	n.a.	1	0.3	during inversion	90°	no	yes
F4H5	solution	n.a.	1	0.3	after inversion	0°	no	yes
F4H5	solution	n.a.	1	0.3	after inversion	90°	no	yes

Herein, the inversion method or the underpressure method were considered successful (“yes”) when no drops within 30 seconds were unintentionally released from the dropper mouth (7) of the dropper bottle in an uncontrolled fashion without any pressure applied to the deformable wall part (1C) of the dropper bottle (1). Further, “(yes)” in brackets refers to only one drop unintentionally released within said 30 second observation period.

Example 7: Testing the Underpressure Method with Different Volumes and Temperatures

According to the protocols as described under example 6 above for the inversion method and the underpressure method, respectively, further measurements were carried out at 21° C. and 5° C. with increasing gaseous phase (3) (headspace volume) in the interior volume of the dropper bottle (1). The results are listed in Table 3:

TABLE 3

Solvent	Formulation type	dropper type	temperature/° C.	composition volume/ml	inversion method successful	underpressure method successful
F6H8	solution	1	21	5	no	yes
F6H8	solution	1	21	4	no	yes
F6H8	solution	1	21	3	no	yes
F6H8	solution	1	21	2	no	yes
F6H8	solution	1	21	1	no	yes
F6H8	solution	2	21	5	no	yes
F6H8	solution	2	21	4	no	yes
F6H8	solution	2	21	3	no	yes
F6H8	solution	2	21	2	no	yes
F6H8	solution	2	21	1	no	yes
F6H8	solution	1	5	5	no	yes
F6H8	solution	1	5	4	no	yes
F6H8	solution	1	5	3	no	yes
F6H8	solution	1	5	2	no	yes
F6H8	solution	1	5	1	no	yes
F6H8	solution	2	5	5	no	yes
F6H8	solution	2	5	4	no	yes

31

TABLE 3-continued

Solvent	Formulation type	dropper type	temperature/° C.	composition volume/ml	inversion method successful	underpressure method successful
F6H8	solution	2	5	3	no	yes
F6H8	solution	2	5	2	no	yes
F6H8	solution	2	5	1	no	yes

Herein, the inversion method or the underpressure method were considered successful (“yes”) when no drops within 30 seconds were unintentionally released from the dropper mouth (7) of the dropper bottle in an uncontrolled fashion without any pressure applied to the deformable wall part (1C) of the dropper bottle (1). Further, “(yes)” in brackets refers to only one drop unintentionally released within said 30 second observation period.

Example 8: Comparative Drop Size Analysis of Polypropylene Drop Dispenser with Different Outflow Channel Diameters Filled with F6H8 at Different Fill Levels

Three polypropylene droppers (Packsys®) with a duct opening diameter of 0.3 mm and a mouth diameter of 2.4 mm (“Dropper 14182”) were filled with 1 ml, 3 ml and 5 ml of F6H8. Prior to testing the bottles were closed with dropper and cap. The cap was removed and sample fluid F6H8 was dispensed dropwise. 5 drops of F6H8 were collected from the start, middle and end of each sample (5 ml; 3 ml; 1 ml respectively) were weighed and the corresponding drop sizes calculated on the basis of the density of F6H8 (1.331 gcm⁻³). Table 4 shows the resulting average drop weights and volumes:

TABLE 4

Dropper 14182	F6H8			
	5 mL	3 mL	1 mL	Average
Average Drop Weight (mg)	14.967	15.458	15.035	15.153
% RSD of Drop Weight	0.940	0.873	1.061	0.964
Average Drop Volume (µL)	11.245	11.614	11.296	11.385
% RSD of Drop Size	0.706	0.656	0.797	0.725

The experiment was repeated using three polypropylene droppers (Packsys®) with a duct opening diameter of 0.15 mm and a mouth diameter of 2.4 mm (“Dropper 14014”). Table 5 shows the resulting average drop weights and volumes:

TABLE 5

Dropper 14014	F6H8			
	5 mL	3 mL	1 mL	Through-Life
Average Drop Weight (mg)	14.509	14.540	14.498	14.516
% RSD of Drop Weight	0.646	0.760	0.699	0.687
Average Drop Volume (µL)	10.901	10.924	10.893	10.906
% RSD of Drop Size	0.486	0.571	0.525	0.516

Table 6 shows the drop weights in mg as measured for the three droppers, each having a duct opening diameter of 0.3 mm and a mouth diameter of 2.4 mm (Dropper 14182).

32

TABLE 6

Fill	14182		
	F6H8 Drop Weight (mg)		
Volume	1	2	3
5 mL	15.260	16.089	14.115
	13.397	15.257	13.251
	15.168	15.620	16.119
	14.873	14.525	16.155
3 mL	14.105	14.813	15.753
	15.693	14.928	17.034
	15.739	15.120	16.204
	14.668	14.648	16.424
1 mL	15.949	14.665	16.584
	15.058	13.855	15.295
	14.637	15.426	16.599
	14.877	13.054	16.255
	13.947	14.200	13.827
	15.543	14.526	16.084
	16.526	14.572	15.451

Table 7 shows the comparison of the drop sizes generated with droppers having a duct opening of either 0.3 mm or 0.15 mm. As can be seen, a smaller diameter of the duct opening helps to adjust the drop volume to a target drop volume of 10,11. Furthermore, a smaller duct opening allows to realize more constant drop volumes, independent from the fill level of the dropper bottle used.

TABLE 7

	Material: F6H8			
	5 mL	3 mL	1 mL	Average
14182 Average Drop Volume (µL)	11.245	11.614	11.296	11.385
14182 % RSD of Drop Size	0.706	0.656	0.797	0.725
14014 Average Drop Volume (µL)	10.901	10.924	10.893	10.906
14014 % RSD of Drop Size	0.486	0.571	0.525	0.516

Example 9: Testing of a Polypropylene Drop Dispenser with a Duct Opening Diameter of 0.15 mm at Reduced Temperature at 5° C. with F4H5 and F6H8

A drop dispenser (Packsys GmbH) with a volume of 5 ml, a duct opening with a diameter of 0.15 mm and a dropper mouth with a diameter of 2.4 mm was tested at 5° C. with F4H5 and F6H8 at different volumes.

Three of the above-described polypropylene dropper bottles were filled with different volumes of F4H5 and F6H8 (5 ml; 3 ml; 1 ml). Prior to testing, the bottles were closed with dropper and cap; then stored over night at 5° C. This was repeated with the three bottles containing each material.

Without pressing the bottle was automatically inverted by 180° for 30 seconds. Drop formation of F4H5 or F6H8 and release was observed on blue paper and counted. For data analysis purposes any droplet that failed to drop but was observed was counted as a drop. Table 8 shows the number of drops observed.

TABLE 8

Fill	F4H5			F6H8		
	1	2	3	1	2	3
Volume						
5 mL	0	0	0	0	0	0
3 mL	2	3	2	0	1	1
1 mL	2	2	1	1	2	2

Furthermore, 5 drops of each SFA was collected from each of the 3 parallel drop dispensers from the start, middle and end of each sample (5 ml; 3 ml; 1 ml respectively), weighed and the drop size calculated on the basis of the respective density (F4H5, 1.29 g/cm³; F6H8, 1.331 g/cm³). Table 9 shows the drop sizes observed for each of the 3 drop dispensers tested in parallel.

TABLE 9

Fill	F4H5 Drop Weight (mg)			F6H8 Drop Weight (mg)		
	1	2	3	1	2	3
Volume						
5 mL	14.209	13.560	13.998	15.391	15.448	15.265
	15.132	13.543	13.160	15.078	15.406	16.189
	14.408	12.940	15.184	14.308	15.406	16.092
3 mL	13.724	12.989	13.177	15.714	16.137	15.987
	12.268	13.932	13.449	14.587	15.864	15.310
	12.881	14.085	13.914	15.749	15.819	15.696
	15.184	12.648	14.611	12.865	15.067	15.597
	13.935	13.912	14.462	15.587	14.946	16.227
	13.287	12.881	13.411	14.672	15.383	15.440
1 mL	13.176	13.687	14.569	15.909	15.022	15.446
	14.651	13.984	14.068	15.845	13.675	13.202
	13.519	13.997	13.428	15.345	15.501	15.472
	13.473	14.600	13.841	15.019	15.541	15.680
	13.211	10.317	13.176	15.501	13.537	14.010
	12.102	13.885	12.675	14.160	14.996	14.869

Table 10 shows the average weights as well as the average volumes of the observed drops.

TABLE 10

Summary	F4H5				F6H8			
	5 ml	3 ml	1 ml	Average	5 ml	3 ml	1 ml	Average
Average Drop Weight (mg)	13.712	13.776	13.395	13.628	15.479	15.295	14.824	15.199
% RSD of Drop Weight	0.800	0.734	1.082	0.881	0.547	0.786	0.873	0.783
Average Drop volume (µl)	10.629	10.679	10.384	10.564	11.629	11.491	11.137	11.419
% RSD of Drop size	0.620	0.569	0.839	0.683	0.411	0.591	0.656	0.588

Example 10: Testing of a Polypropylene Drop Dispenser with a Duct Opening Diameter of 0.15 Mm Filled with F6H8 at Different Filling Levels

In this experiment 3 series of 5 polypropylene droppers with a duct opening diameter of 0.15 mm and a mouth diameter of 2.4 mm ("Dropper 14014") and a total volume of 5 ml were filled with F6H8 at different filling volumes: 5 droppers (droppers 1 to 5) were filled with 0.2 ml F6H8 each (filling level "nearly empty"); 5 droppers were filled with 3

ml F6H8 each (filling level "half full") and 5 droppers were filled with 5 ml F6H8 each (filling level "full") at room temperature. The dropper bottles were opened and inverted by 180° to a vertical orientation with the dropper mouth pointing downwards. For a period of 10 s it was observed whether the spontaneous formation of drops occurred. The drops, if formed, were counted. Table 11 summarizes the results of the experiment with "OK" depicting that no drops were formed within 10 s from the inversion of the bottle.

TABLE 11

Dropper	Filling volume 0.2 ml (nearly empty)	Filling volume 3 ml (half full)	Filling volume 5 ml (full)
1	OK	OK	OK
2	OK	OK	OK
3	OK	OK	OK
4	OK	OK	OK
5	OK	OK	OK

The invention claimed is:

1. A method for dropwise topical administration of a liquid composition (2), comprising the steps of:
 - a) providing a drop dispenser (1), comprising:
 - a container part (1B) with an interior volume partially filled with the liquid composition (2) and a gaseous phase (3) filling the remainder of the interior volume at ambient pressure, the container part (1B) having a displaceable section (1C) and optionally a substantially stationary section, and
 - a dropper part (1A) in physical connection and in fluid communication with the interior volume of the container part (1B), comprising an outflow channel (5), connecting the interior volume of the container part (1B) to the environment;

- b) exerting a first force to the displaceable section (1C) of the container part (1B) of the drop dispenser (1) while holding the drop dispenser (1) in an upright position in which the outflow channel (5) is not in contact with the liquid composition (2), thereby reducing the interior volume of the container part (1B) and forcing the gaseous phase (3) of the interior volume at least partially out of the drop dispenser (1) into the environment;

- c) inverting the drop dispenser (1) to an inverted position in which the liquid composition (2) is in contact with the outflow channel (5);
- d) releasing said first force from the displaceable section (1C) of the container part (1B) at least partly, thereby reducing the pressure inside the container part (1B) below ambient pressure; and
- e) exerting a second force to the displaceable section (1C) of the container part (1B), while still holding the drop dispenser in the inverted position in which the liquid composition (2) is in contact with the outflow channel (5), thereby raising the pressure inside the interior volume of the container part (1B) above ambient pressure and releasing the liquid composition (2) dropwise from the dropper part (1A) of the drop dispenser (1).
2. The method according to claim 1, wherein the drop dispenser (1) is a dropper bottle with a dropper part (1A) and a container part (1B), the container part (1B) comprising the displaceable section (1C).
3. The method according to claim 1, wherein the inversion of the drop dispenser (1) to the inverted position according to step (c) and the release of the first force according to step (d) is performed at least partly simultaneously.
4. The method according to claim 1, wherein the liquid composition (2) is an ophthalmic composition.
5. The method according to claim 1, wherein the liquid composition (2) comprises a liquid semifluorinated alkane.
6. The method according to claim 1, wherein the liquid composition (2) further comprises water.
7. The method according to claim 1, wherein the reduced pressure generated inside the interior volume of the container part (1B) prevents unintended release of the liquid composition (2).
8. The method according to claim 1, wherein the liquid composition (2) has a density measured at 25° C. in the range of 1.0 to 1.7 g/cm³.
9. The method according to claim 1, wherein the liquid composition (2) has a viscosity measured at 25° C. in air in the range of 0.9 to 4.0 mPa s.
10. The method according to claim 1, wherein the liquid composition (2) has a surface tension in air measured at 25° C. in the range of 15 to 30 mN/m.
11. The method according to claim 1, wherein the liquid composition (2) comprises a liquid linear or branched semifluorinated alkane having one perfluorinated segment and one non-fluorinated hydrocarbon segment.
12. The method according to claim 1, wherein the liquid composition (2) further comprises one or more pharmaceutical active ingredients.
13. The method according to claim 1, further comprising the step:
- f) dropwise administering the liquid composition (2) to the eye, eye lid, eye sac or an ophthalmic tissue of a subject in need thereof.
14. A method of treating an ocular disease or disorder, or any symptoms or conditions associated therewith, comprising dropwise administration of a liquid ophthalmic composition according to the method of claim 1.
15. The method according to claim 14, wherein the ocular disease or disorder is dry eye disease.
16. The method according to claim 14, wherein the ocular disease or disorder is a disease or disorder of the eyelid, lacrimal system, orbit, conjunctiva, sclera, cornea, iris, ciliary body, lens, choroid and/or retina.
17. The method according to claim 11, wherein each segment independently has a number of carbon atoms selected from the range of 3 to 10.

18. The method according to claim 5, wherein the liquid semifluorinated alkane is selected from the group consisting of F4H5, F4H6, F5H6, F5H7, F6H6, F6H7, and F6H8.
19. The method according to claim 18, wherein the liquid semifluorinated alkane is F4H5.
20. The method according to claim 18, wherein the liquid semifluorinated alkane is F6H8.
21. The method according to claim 1, wherein the liquid composition (2) is an ophthalmic composition comprising 1-perfluorohexyloctane (F6H8).
22. The method according to claim 1, wherein the liquid composition (2) is an ophthalmic composition comprising 1 mg/ml Cyclosporine A and 1 wt-% ethanol in 1-perfluorobutyl-pentane (F4H5).
23. The method according to claim 22, wherein the liquid composition (2) is an ophthalmic composition consisting essentially of 1 mg/ml Cyclosporine A and 1 wt-% ethanol in 1-perfluorobutyl-pentane (F4H5).
24. The method according to claim 21, wherein the ophthalmic composition is administered to treat dry eye disease.
25. The method according to claim 22, wherein the ophthalmic composition is administered to treat dry eye disease.
26. The method according to claim 13, wherein the administering of the liquid composition (2) is carried out up to once per week, or up to once per day or up to 8, 7, 6, 5, 4, 3 or up to 2 times per day.
27. The method according to claim 1, wherein the outflow channel (5) narrows from a proximal dropper mouth (7) to a distal duct opening (4).
28. The method according to claim 27, wherein the drops to be released are formed at the dropper mouth (7) at the proximal end of the outflow channel (5).
29. The method according to claim 27, wherein the duct opening (4) is circular.
30. The method according to claim 29, wherein the duct opening (4) has a diameter in the range of from 0.15 to 1.2 mm, or in the range of from 0.18 to 0.5 mm, or in the range of from 0.2 to 0.3 mm.
31. The method according to claim 27, wherein the diameter of the dropper mouth (7) is between 1 and 5 mm, or is between 2 and 3 mm, or is between 2.0 and 2.6 mm, or is about 2.0 to 2.4 mm.
32. The method according to claim 1, wherein displaceable section (1C) comprises a deformable wall which is manually deformable.
33. The method according to claim 32, wherein the displaceable section (1C) comprises a deformable wall having a wall thickness of between 0.4 and 1.6 mm, or between 0.5 and 1.0 mm, or between 0.6 and 0.8 mm.
34. The method according to claim 1, wherein the exerting a first force of step (b), and the exerting a second force of step (e), are each provided by manually compressing or squeezing the displaceable section (1C).
35. The method according to claim 14, wherein the liquid ophthalmic composition comprises a liquid semifluorinated alkane selected from the group consisting of F4H5, F4H6, F5H6, F5H7, F6H6, F6H7, and F6H8.
36. The method according to claim 35, wherein the liquid semifluorinated alkane is F4H5.
37. The method according to claim 35, wherein the liquid semifluorinated alkane is F6H8.
38. The method according to claim 14, wherein the ophthalmic composition comprises 1 mg/ml Cyclosporine A and 1 wt-% ethanol in 1-perfluorobutyl-pentane (F4H5).

37

39. The method according to claim 36, wherein the ophthalmic composition consists essentially of 1 mg/ml Ciclosporine A and 1 wt-% ethanol in 1-perfluorobutylpentane (F4H5).

40. The method according to claim 38, wherein the ocular disease or disorder is dry eye disease.

41. The method according to claim 14, wherein the ophthalmic composition comprises 1-perfluorohexyloctane (F6H8).

42. The method according to claim 41, wherein the ocular disease or disorder is dry eye disease.

43. The method according to claim 14, wherein the method comprises administration of the ophthalmic composition up to once per week, or up to once per day or up to 8, 7, 6, 5, 4, 3 or up to 2 times per day.

44. The method according to claim 19, wherein the liquid composition (2) further comprises a branched semifluorinated alkane having a linear perfluorinated segment having 4-10 carbon atoms and a branched non-fluorinated hydrocarbon segment having 4-10 carbon atoms and including one $-\text{CH}_3$ alkyl group, and wherein the ratio of carbon atoms of the perfluorinated segment and the hydrocarbon segment is between 0.6 and 1.0.

45. The method according to claim 20, wherein the liquid composition (2) further comprises a branched semifluorinated alkane having a linear perfluorinated segment having 4-10 carbon atoms and a branched non-fluorinated hydrocarbon segment having 4-10 carbon atoms and including one $-\text{CH}_3$ alkyl group, and wherein the ratio of carbon atoms of the perfluorinated segment and the hydrocarbon segment is between 0.6 and 1.0.

38

46. The method according to claim 36, wherein the liquid ophthalmic composition further comprises a branched semifluorinated alkane having a linear perfluorinated segment having 4-10 carbon atoms and a branched non-fluorinated hydrocarbon segment having 4-10 carbon atoms and including one $-\text{CH}_3$ alkyl group, and wherein the ratio of carbon atoms of the perfluorinated segment and the hydrocarbon segment is between 0.6 and 1.0.

47. The method according to claim 37, wherein the liquid ophthalmic composition further comprises a branched semifluorinated alkane having a linear perfluorinated segment having 4-10 carbon atoms and a branched non-fluorinated hydrocarbon segment having 4-10 carbon atoms and including one $-\text{CH}_3$ alkyl group, and wherein the ratio of carbon atoms of the perfluorinated segment and the hydrocarbon segment is between 0.6 and 1.0.

48. The method according to claim 14, wherein the liquid ophthalmic composition consists essentially of 1-perfluorohexyloctane (F6H8) and wherein the liquid ophthalmic composition is administered to treat dry eye disease.

49. The method according to claim 48, wherein the liquid ophthalmic composition further comprises a branched semifluorinated alkane having a linear perfluorinated segment having 4-10 carbon atoms and a branched non-fluorinated hydrocarbon segment having 4-10 carbon atoms and including one $-\text{CH}_3$ alkyl group, and wherein the ratio of carbon atoms of the perfluorinated segment and the hydrocarbon segment is between 0.6 and 1.0.

* * * * *