

(19) World Intellectual Property
Organization
International Bureau



(43) International Publication Date
27 May 2004 (27.05.2004)

PCT

(10) International Publication Number
WO 2004/044955 A2

- (51) International Patent Classification⁷: **H01L** 130 Oakwood Lane, Ithaca, NY 14850 (US). **MARKLE, David, A.**; 20690 Ritanna Court, Saratoga, CA 95070 (US).
- (21) International Application Number: PCT/US2003/035236
- (22) International Filing Date: 3 November 2003 (03.11.2003)
- (25) Filing Language: English
- (26) Publication Language: English
- (30) Priority Data: 10/287,864 6 November 2002 (06.11.2002) US
- (71) Applicant: **ULTRATECH STEPPER, INC.** [US/US]; 3050 Zanker Road, San Jose, CA 95134 (US).
- (72) Inventors: **TALWAR, Somit**; 116 Adrian Place, Los Gatos, CA 95032 (US). **THOMPSON, Michael, O.**
- (74) Agent: **JONES, Allston, L.**; Peters, Verny, Jones & Schmitt, L.L.P., 425 Sherman Avenue, Suite 230, Palo Alto, CA 94306 (US).
- (81) Designated States (*national*): JP, KR.
- (84) Designated States (*regional*): European patent (AT, BE, BG, CH, CY, CZ, DE, DK, EE, ES, FI, FR, GB, GR, HU, IE, IT, LU, MC, NL, PT, RO, SE, SI, SK, TR).
- Published:**
— without international search report and to be republished upon receipt of that report
- For two-letter codes and other abbreviations, refer to the "Guidance Notes on Codes and Abbreviations" appearing at the beginning of each regular issue of the PCT Gazette.*

(54) Title: LASER SCANNING APPARATUS AND METHODS FOR THERMAL PROCESSING

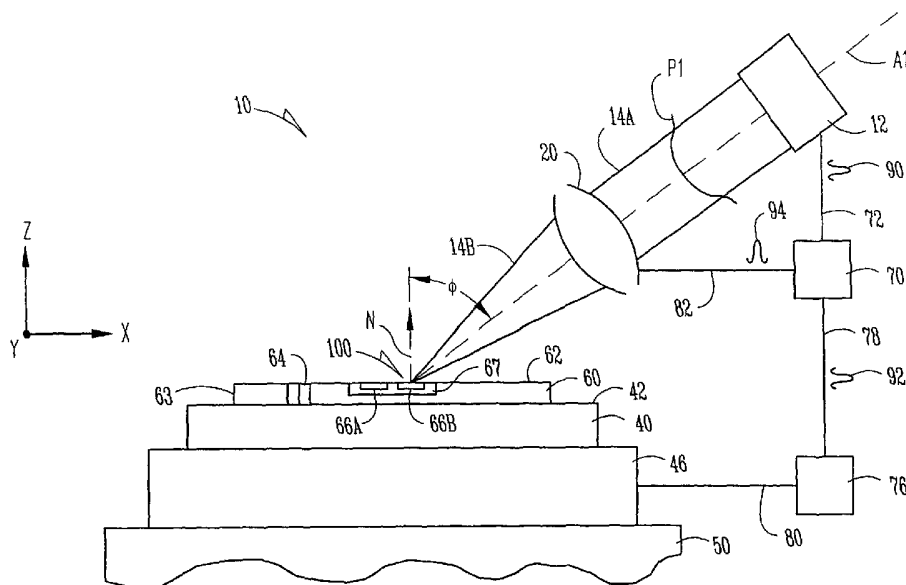

(57) Abstract: Apparatus and methods for thermally processing a substrate with scanned laser radiation are disclosed. The apparatus includes a continuous radiation source and an optical system that forms an image on a substrate. The image is scanned relative to the substrate surface so that each point in the process region receives a pulse of radiation sufficient to thermally process the region.

WO 2004/044955 A2

Laser Scanning Apparatus and Methods for Thermal Processing

BACKGROUND OF THE INVENTION

Field of the Invention

5 The present invention relates to apparatus and methods for thermally processing substrates, and in particular semiconductor substrates with integrated devices or circuits formed thereon.

Description of the Prior Art

 The fabrication of integrated circuits (ICs) involves subjecting a semiconductor
10 substrate to numerous processes, such as photoresist coating, photolithographic exposure, photoresist development, etching, polishing, and heating or "thermal processing." In certain applications, thermal processing is performed to activate dopants in doped regions (e.g., source and drain regions) of the substrate. Thermal processing includes various heating (and cooling) techniques, such as rapid thermal annealing (RTA) and laser thermal processing
15 (LTP). Where a laser is used to perform thermal processing, the technique is sometimes called "laser processing" or "laser annealing."

 Various techniques and systems for laser processing of semiconductor substrates have been known and used in the integrated circuit (IC) fabrication industry. Laser processing is preferably done in a single cycle that brings the temperature of the material
20 being annealed up to the annealing temperature and then back down to the starting (e.g., ambient) temperature.

 Substantial improvements in IC performance are possible if the thermal processing cycles required for activation, annealing, etc. can be kept to a millisecond or less. Thermal cycle times shorter than a microsecond are readily obtained using radiation from a pulsed
25 laser uniformly spread over one or more circuits. An example system for performing laser thermal processing with a pulsed laser source is described in U.S. Patent No. 6,366,308 B1, entitled "Laser Thermal Processing Apparatus and Method." However the shorter the radiation pulse, the shallower the region that can be heat-treated, and the more likely that the circuit elements themselves will cause substantial temperature variations. For example, a
30 polysilicon conductor residing on a thick, field-oxide isolator is heated much more quickly than a shallow junction at the surface of the silicon wafer.

 A more uniform temperature distribution can be obtained with a longer radiation pulse since the depth of heating is greater and there is more time available during the pulse interval for lateral heat conduction to equalize temperatures across the circuit. However, it
35 is impractical to extend laser pulse lengths over periods longer than a microsecond and over circuit areas of 5cm² or more because the energy per pulse becomes too high, and the laser and associated power supply needed to provide such high energy becomes too big and

expensive.

An alternative approach to using pulsed radiation is to use continuous radiation. An example thermal processing apparatus that employs a continuous radiation source in the form of laser diodes is disclosed in U.S. Patent Application No. 09/536,869, entitled
5 “Apparatus Having Line Source of Radiant Energy for Exposing a Substrate,” which application was filed on March 27, 2000 and is assigned to the same assignee as this application. Laser diode bar arrays can be obtained with output powers in the 100 W/cm range and can be imaged to produce line images about a micron wide. They are also very efficient at converting electricity into radiation. Further, because there are many diodes in a
10 bar each operating at a slightly different wavelength, they can be imaged to form a uniform line image.

However, using diodes as a continuous radiation source is optimally suited only for certain applications. For example, when annealing source and drain regions having a depth less than say one micron or so, it is preferred that the radiation not be absorbed in the silicon
15 beyond this depth. Unfortunately, the absorption depth for a typical laser diode operating at wavelength of 0.8 micron is about 20 microns for room temperature silicon. Thus, in thermal processing applications that seek to treat the uppermost regions of the substrate (e.g., shallower than say one microns), most of the diode-based radiation penetrates into a silicon wafer much farther than required or desired. This increases the total power required.
20 While a thin absorptive coating could be used to reduce this problem, it adds complexity to what is already a rather involved manufacturing process.

SUMMARY OF THE INVENTION

An aspect of the invention is an apparatus for thermally processing a region of a substrate. The apparatus includes a continuous radiation source capable of providing a
25 continuous radiation beam with a first intensity profile and a wavelength capable of heating the substrate region. An optical system is arranged downstream of the continuous radiation source and is adapted to receive the radiation beam and form a second radiation beam, which forms an image at the substrate. In an example embodiment, the image is a line image. The apparatus also includes a stage adapted to support the substrate. At least one of
30 the optical system and the stage is adapted to scan the image with respect to the substrate in a scan direction to heat the region with a pulse of radiation to a temperature sufficient to process the region.

Another aspect of the invention is a method of thermally processing a region of a substrate. The method includes generating a continuous beam of radiation having a
35 wavelength capable of heating the substrate region, and then scanning the radiation over the region in a scan direction so that each point in the region receives an amount of thermal energy capable of processing the substrate region.

BRIEF DESCRIPTION OF THE DRAWINGS

FIG. 1A is a schematic diagram of a generalized embodiment of the apparatus of the present invention;

FIG. 1B illustrates an example embodiment of an idealized line image with a long dimension L1 and a short dimension L2 as formed on the substrate by the apparatus of FIG. 1A;

FIG. 1C is a two-dimensional plot representative of the intensity distribution associated with an actual line image;

FIG. 1D is a schematic diagram of an example embodiment of an optical system for the apparatus of FIG. 1A that includes conic mirrors to form a line image at the substrate surface;

FIG. 2A is a schematic diagram illustrating an example embodiment of the laser scanning apparatus of FIG. 1A, further including a beam converter arranged between the radiation source and the optical system;

FIG. 2B is a schematic diagram illustrating how the beam converter of the apparatus of FIG. 2A modifies the profile of a radiation beam;

FIG. 2C is a cross-sectional view of an example embodiment of a converter/ optical system that includes a Gaussian-to-flat-top converter;

FIG. 2D is a plot of an example intensity profile of an unvignetted radiation beam, such as formed by the converter/optical system of FIG. 2C;

FIG. 2E is the plot as FIG. 2D with the edge rays vignetted by a vignetting aperture to reduce the intensity peaks at the ends of image;

FIG. 3 is a schematic diagram similar to that of the apparatus of FIG. 1A with additional elements representing different example embodiments of the invention;

FIG. 4 illustrates an example embodiment of the reflected radiation monitor of the apparatus of FIG. 3 in which the incident angle Φ is equal to or near 0° ;

FIG. 5 is a close-up view of an example embodiment of the diagnostic system of the apparatus of FIG. 3 as used to measure the temperature of the substrate at or near the location of the image as it is scanned;

FIG. 6 is a profile (plot) of the relative intensity versus wavelength for a 1410°C black body, which temperature is slightly above that used to activate dopants in the source and drain regions of a semiconductor transistor;

FIG. 7 is a close-up isometric view of a substrate having features aligned in a grid pattern illustrating 45 degree orientation of the plane containing the incident and reflected laser beams relative to the grid pattern features;

FIG. 8 plots the reflectivity versus incidence angle for both p and s polarization directions of a 10.6 micron laser radiation beam reflecting from the following surfaces: (a)

bare silicon, (b) a 0.5 micron oxide isolator on top of the silicon, (c) a 0.1 micron, polysilicon runner on top of a 0.5 micron oxide isolator on silicon, and (d) an infinitely deep silicon oxide layer;

FIG. 9 is a top-down isometric view of an embodiment of the apparatus of the present invention as used to process a substrate in the form of a semiconductor wafer having a grid pattern formed thereon, illustrating operation of the apparatus in an optimum radiation beam geometry;

FIG. 10 is a plan view of a substrate illustrating a boustrophedonic scanning pattern of the image over the substrate surface;

FIG. 11 is a cross-sectional view of an example embodiment of an optical system that includes a movable scanning mirror;

FIG. 12 is a plan view of four substrates residing on a stage capable of moving both rotationally and linearly to perform spiral scanning of the image over the substrates;

FIGS. 13A and 13B are plan views of a substrate illustrating an alternate raster scanning pattern wherein the scan paths are separated by a space to allow the substrate to cool before scanning an adjacent scan path; and

FIG. 14 is a plot of the simulated throughput in substrates/hour vs. the dwell time in microseconds for the spiral scanning method, the optical scanning method and the boustrophedonic scanning method for the apparatus of the present invention.

The various elements depicted in the drawings are merely representational and are not drawn to scale. Certain proportions thereof may be exaggerated, while others may be minimized. The drawings are intended to illustrate various implementations of the invention, which can be understood and appropriately carried out by those of ordinary skill in the art.

DETAILED DESCRIPTION OF THE INVENTION

In the following detailed description of the embodiments of the invention, reference is made to the accompanying drawings that form a part hereof, and in which is shown by way of illustration specific embodiments in which the invention may be practiced. These embodiments are described in sufficient detail to enable those skilled in the art to practice the invention, and it is to be understood that other embodiments may be utilized and that changes may be made without departing from the scope of the present invention. The following detailed description is, therefore, not to be taken in a limiting sense, and the scope of the present invention is defined only by the appended claims.

General apparatus and method

FIG. 1A is a schematic diagram of a generalized embodiment of the laser scanning apparatus of the present invention. Apparatus 10 of FIG. 1A includes, along an optical axis A1, a continuous radiation source 12 that emits a continuous radiation beam 14A having output power and an intensity profile P1 as measured at right angles to the optical axis. In

an example embodiment, radiation beam 14A is collimated. Also in an example embodiment, radiation source 12 is a laser and radiation beam 14A is a laser beam. Further in the example embodiment, radiation source 12 is a carbon dioxide (CO₂) laser operating at a wavelength between about 9.4 microns and about 10.8 microns. A CO₂ laser is a very efficient converter of electricity into radiation and its output beam is typically very coherent so that profile P1 is Gaussian. Further, the infrared wavelengths generated by a CO₂ laser are suitable for processing (e.g., heating) silicon (e.g., a silicon substrate such as semiconductor wafer), as discussed below. Also in an example embodiment, radiation beam 14A is linearly polarized and can be manipulated so that the radiation incident on the substrate includes only a p-polarization state P, or only a s-polarization state S, or both. Because radiation source 12 emits a continuous radiation beam 14A, it is referred to herein as a "continuous radiation source." Generally, radiation beam 14A includes radiation of a wavelength that is absorbed by the substrate and is therefore capable of heating the substrate.

Apparatus 10 also includes an optical system 20 downstream from radiation source 12 that modifies (e.g., focuses or shapes) radiation beam 14A to form a radiation beam 14B. Optical system 20 can consist of a single element (e.g., a lens element or a mirror) or can be made of multiple elements. In an example embodiment, optical system 20 may also include movable elements, such as a scanning mirror, as discussed in greater detail below.

Apparatus 10 further includes, downstream from optical system 20, a chuck 40 with an upper surface 42. Chuck 40 is supported by stage 46 that in turn is supported by a platen 50. In an example embodiment, chuck 40 is incorporated into stage 46. In another example embodiment, stage 46 is movable. Further in an example embodiment, substrate stage 46 is rotatable about one or more of the x, y and z axes. Chuck upper surface 42 is capable of supporting a substrate 60 having a surface 62 with a surface normal N, and an edge 63.

In an example embodiment, substrate 60 includes a reference feature 64 to facilitate alignment of the substrate in apparatus 10, as described below. In an example embodiment, reference feature 64 also serves to identify the crystal orientation of a monocrystalline substrate 60. In an example embodiment, substrate 60 is a monocrystalline silicon wafer, such as described in document #Semi M1-600, "Specifications for Polished Monocrystalline Silicon Wafers," available from SEMI (Semiconductor Equipment and Materials International), 3081 Zanker Road, San Jose 95134, which document is incorporated by reference herein.

Further in an example embodiment, substrate 60 includes source and drain regions 66A and 66B formed at or near surface 62 as part of a circuit (e.g., transistor) 67 formed in the substrate. In an example embodiment, source and drain regions 66A and 66B are

shallow, having a depth into the substrate of one micron or less.

Axis A1 and substrate normal N form an angle Φ , which is the incident angle ϕ that radiation beam 14B (and axis A1) makes with substrate surface normal N. In an example embodiment, radiation beam 14B has an incident angle $\phi > 0$ to ensure that radiation
5 reflected from substrate surface 62 does not return to radiation source 12. Generally, the incident angle can vary over the range $0^\circ \leq \phi < 90^\circ$. However, certain applications benefit from operating the apparatus at select incident angles within this range, as described in greater detail below.

In an example embodiment, apparatus 10 further includes a controller 70 coupled to
10 radiation source 12 via a communication line ("line") 72 and coupled to a stage controller 76 via a line 78. Stage controller 76 is operably coupled to stage 46 via a line 80 to control the movement of the stage. In an example embodiment, controller 70 is also coupled to optical system 20 via a line 82. Controller 70 controls the operation of radiation source 12, stage controller 76, and optical system 20 (e.g., the movement of elements therein) via respective
15 signals 90, 92 and 94.

In one example embodiment, one or more of lines 72, 78, 80 and 82 are wires and corresponding one or more of signals 90, 92 and 94 are electrical signals, while in another example embodiment one or more of the aforementioned lines are an optical fiber and corresponding one or more of the aforementioned signals are optical signals.

In an example embodiment, controller 70 is a computer, such as a personal computer
20 or workstation, available from any one of a number of well-known computer companies such as Dell Computer, Inc., of Austin Texas. Controller 70 preferably includes any of a number of commercially available micro-processors, such as the Intel PENTIUM series, or AMD K6 or K7 processors, a suitable bus architecture to connect the processor to a
25 memory device, such as a hard disk drive, and suitable input and output devices (e.g., a keyboard and a display, respectively).

With continuing reference to FIG. 1A, radiation beam 14B is directed by optical system 20 onto substrate surface 62 along axis A1. In an example embodiment, optical system 20 focuses radiation beam 14B to form an image 100 on substrate surface 62. The
30 term "image" is used herein in to generally denote the distribution of light formed on substrate surface 62 by radiation beam 14B. Thus, image 100 does not necessarily have an associated object in the classical sense. Further, image 100 is not necessarily formed by bringing light rays to a point focus. For example, image 100 can be an elliptical spot formed by an anamorphic optical system 20, as well as a circular spot formed a normally incident,
35 focused beam formed from a circularly symmetric optical system. Also, the term "image" includes the light distribution formed on substrate surface 62 by intercepting beam 14B with substrate 60.

Image 100 may have any number of shapes, such as a square, rectangular, oval, etc. Also, image 100 can have a variety of different intensity distributions, including ones that correspond to a uniform line image distribution. FIG. 1B illustrates an example embodiment of image 100 as a line image. An idealized line image 100 has a long dimension (length) L1, a short dimension (width) L2, and uniform (i.e., flat-top) intensity. In practice, line image 100 is not entirely uniform because of diffraction effects.

FIG. 1C is a two-dimensional plot representative of the intensity distribution associated with an actual line image. For most applications, the integrated cross-section in the short dimension L2 need only be substantially uniform in the long dimension L1, with an integrated intensity distribution uniformity of about $\pm 2\%$ over the operationally useful part of the image.

With continuing reference to FIGS. 1B and 1C, in an example embodiment, length L1 ranges from about 1.25 cm to 4.4 cm, and width L2 is about 50 microns. In another example embodiment, length L1 is 1cm or less. Further in an example embodiment, image 100 has an intensity ranging from 50 kW/cm² to 150 kW/cm². The intensity of image 100 is selected based on how much energy needs to be delivered to the substrate for the particular application, the image width L2, and how fast the image is scanned over substrate surface 62.

FIG. 1D is a schematic diagram of an optical system 20 that includes conic mirrors M1, M2 and M3 to form a line image at the substrate surface. Optical system 20 of FIG. 1D illustrates how a segment of a reflective cone can be used to focus a collimated beam into a line image 100. Optical system 20 comprises, in one example embodiment, parabolic cylindrical mirror segments M1 and M2 and a conic mirror segment M3. Conic mirror segment M3 has an axis A3 associated with the whole of the conic mirror (shown in phantom). Axis A3 is parallel to collimated beam 14A and lies along substrate surface 62.

Line image 100 is formed on substrate surface 62 along axis A3. The advantage of this arrangement for optical system 20 is that it produces a narrow, diffraction-limited image 100 with a minimal variation in incident angle ϕ . The length L1 of the line image depends primarily on incident angle ϕ and the size of the collimated beam measured in the y-direction. Different incident angles ϕ can be achieved by switching different conic mirror segments (e.g., mirror M3') into the path of radiation beam 14A'. The length L1 of line image 100 can be modified by changing the collimated beam size using, for example, adjustable (e.g., zoom) collimating optics 104.

With continuing reference to FIG. 1D, in an example embodiment, the size of collimated beam 14A' can be modified using cylindrical parabolic mirrors M1 and M2. Collimated beam 14A' is first brought to a line focus at point F by the positive, cylindrical, parabolic mirror M1. Before reaching the focus at point F, the focused beam 14A' is

intercepted by negative parabolic mirror M2, which collimates the focused beam. The two cylindrical parabolic mirrors M1 and M2 change the width of the collimated beam in y-direction only. Therefore, the parabolic mirrors M1 and M2 also change the length L1 of line image 100 at substrate surface 62, but not the width L2 of the line image in a direction
5 normal to the plane of the Figure.

Also shown in Figure 1D are alternate parabolic mirrors M1' and M2' and an alternate conical mirror M3', all of which can be brought into predetermined fixed positions in the optical path using, for example, indexing wheels 106, 108 and 110.

With reference again to FIG. 1A, in an example embodiment, substrate surface 62 is
10 scanned under image 100 using one of a number of scanning patterns discussed in greater detail below. Scanning can be achieved in a number of ways, including by moving either substrate stage 46, or radiation beam 14B. Thus, "scanning" as the term is used herein includes movement of the image relative to the surface of the substrate, regardless of how accomplished.

15 By scanning a beam of continuous radiation over substrate surface 62, e.g., over one or more select regions thereof, such as regions 66A and 66B, or one or more circuits such as transistor 67, each irradiated point on the substrate receives a radiation pulse. In an example embodiment employing a 200 microsecond dwell time (i.e., the duration the image resides over a given point), the amount of energy received by each scanned point on the substrate
20 during a single scan ranges from 5 J/cm² to 50 J/cm². Overlapping scans serve to further increase the total absorbed energy. Thus, apparatus 10 allows for a continuous radiation source, rather than a pulsed radiation source, to be used to provide a controlled pulse or burst of radiation to each point on a substrate with energy sufficient to process one or more regions, e.g., circuits or circuit elements formed therein or thereupon. Processing, as the
25 term is used herein, includes among other things, selective melting, explosive recrystallization, and dopant activation.

Further, as the term is used herein, "processing" does not include laser ablation, laser cleaning of a substrate, or photolithographic exposure and subsequent chemical activation of photoresist. Rather, by way of example, image 100 is scanned over substrate 60 to provide
30 sufficient thermal energy to raise the surface temperature of one or more regions therein to process the one or more regions, e.g., activate dopants in source and drain regions 66A and 66B or otherwise alter the crystal structure of the one or more regions. In an example embodiment of thermal processing, apparatus 10 is used to quickly heat and cool, and thereby activate, shallow source and drain regions, i.e., such as source and drain regions
35 66A and 66B of transistor 67 having a depth into the substrate from surface 62 of one micron or less.

Apparatus 10 has a number of different embodiments, as illustrated by the examples

discussed below.

Embodiment with beam converter

In an example embodiment shown in Figure 1A, profile P1 of radiation beam 14A is non-uniform. This situation may arise, for example, when radiation source 12 is a substantially coherent laser and the resultant distribution of energy in the collimated beam is Gaussian, which results in a similar energy distribution when the collimated beam is imaged on the substrate. For some applications, it may be desirable to render radiation beams 14A and 14B into a more uniform distribution and change their size so that image 100 has an intensity distribution and size suitable for performing thermal processing of the substrate for the given application.

FIG. 2A is a schematic diagram illustrating an example embodiment of laser scanning apparatus 10 of FIG. 1A that further includes a beam converter 150 arranged along axis A1 between optical system 20 and continuous radiation source 12. Beam converter 150 converts radiation beam 14A with an intensity profile P1 to a modified radiation beam 14A' with an intensity profile P2. In an example embodiment, beam converter 150 and optical system 20 are combined to form a single converter/optical system 160. Though beam converter 150 is shown as arranged upstream of optical system 20, it could also be arranged downstream thereof.

FIG. 2B is a schematic diagram that illustrates how beam converter 150 converts radiation beam 14A with intensity profile P1 to modified radiation beam 14A' with an intensity profile P2. Radiation beams 14A and 14A' are shown as made up of light rays 170, with the light ray spacing corresponding to the relative intensity distribution in the radiation beams. Beam converter 150 adjusts the relative spacing (i.e., density) of rays 170 to modify profile P1 of radiation beam 14A to form modified radiation beam 14A' with profile P2. In example embodiments, beam converter 150 is a dioptric, catoptric or catadioptric lens system.

FIG. 2C is a cross-sectional view of an example embodiment of a converter/ optical system 160 having a converter 150 that converts radiation beam 14A with a Gaussian profile P1 into radiation beam 14A' with a flat-top (i.e., uniform) profile P2, and an optical system 20 that forms a focused radiation beam 14B and a line image 100. Converter/focusing system 160 of FIG. 2C includes cylindrical lenses L1 through L5. Here, "lenses" can mean individual lens elements or a group of lens elements, i.e., a lens group. The first two cylindrical lenses L1 and L2 act to shrink the diameter of radiation beam 14A, while cylindrical lenses L3 and L4 act expand the radiation beam back to roughly its original size but with a modified radiation beam profile 14A' caused by spherical aberration in the lenses. A fifth cylindrical lens L5 serves as optical system 20 and is rotated 90° relative to the other lenses so that its power is out of the plane of the figure. Lens L5 forms radiation beam 14B

that in turn forms line image 100 on substrate 60.

In an example embodiment, converter/focusing system 160 of FIG. 2C also includes a vignetting aperture 180 arranged upstream of lens L1. This removes the outermost rays of input beam 14A, which rays are overcorrected by the spherical aberration in the system, and
5 which would otherwise result in intensity bumps on the edges of the otherwise flat intensity profile.

FIG. 2D is a plot of an example intensity profile P2 of an unvignetted uniform radiation beam 14A' as might be formed by a typical beam converter 150. Typically, a flat-top radiation beam profile P2 has a flat portion 200 over most of its length, and near beam
10 ends 204 includes intensity peaks 210. By removing the outer rays of the beam with vignetting aperture 180, it is also possible to obtain a more uniform radiation beam profile P2, as illustrated in FIG. 2E.

Although the rise in intensity at beam ends 204 can be avoided by vignetting the outermost rays of radiation beam 14A, some increase in intensity near the beam ends may be
15 desirable to produce uniform heating. Heat is lost in the direction parallel to and normal to line image 100 (FIG. 1B) at beam ends 204. A greater intensity at beam ends 204 thus helps to compensate for the higher heat loss. This results in a more uniform temperature profile in the substrate as image 100 is scanned over substrate 60.

Further example embodiments

FIG. 3 is a schematic diagram of apparatus 10 similar to that of FIG. 1A that further
20 includes a number of additional elements located across the top of the figure and above substrate 60. These additional elements either alone or in various combinations have been included to illustrate additional example embodiments of the present invention. It will be apparent to those skilled in the art how many of the additional elements introduced in FIG. 3
25 are necessary for the operation to be performed by each of the following example embodiments, and whether the elements discussed in a previous example embodiment is also needed in the embodiment then being discussed. For simplicity, FIG. 3 has been shown to include all of the elements needed for these additional example embodiments since some of these embodiments do build on a previously discussed embodiment. These additional
30 example embodiments are discussed below.

Attenuator

With reference to FIG. 3, in one example embodiment, apparatus 10 includes an attenuator 226 arranged downstream of radiation source 12 to selectively attenuate either radiation beam 14A, beam 14A' or beam 14B, depending on the location of the attenuator.
35 In an example embodiment, radiation beam 14A is polarized in a particular direction (e.g., p, s or a combination of both), and attenuator 226 includes a polarizer 227 capable of being rotated relative to the polarization direction of the radiation beam to attenuate the beam. In

another example embodiment, attenuator 226 includes at least one of a removable attenuating filter, or a programmable attenuation wheel containing multiple attenuator elements.

In an example embodiment, attenuator 226 is coupled to controller 70 via a line 228 and is controlled by a signal 229 from the controller.

Quarter-wave plate

In another example embodiment, radiation beam 14A is linearly polarized and apparatus 10 includes a quarter-wave plate 230 downstream of radiation source 12 to convert the linear polarization to circular polarization. Quarter-wave plate 230 works in conjunction with attenuator 226 in the example embodiment where the attenuator includes polarizer 227 to prevent radiation reflected or scattered from substrate surface 62 from returning to radiation source 12. In particular, on the return path, the reflected circularly polarized radiation is converted to linear polarized radiation, which is then blocked by polarizer 227. This configuration is particularly useful where the incident angle ϕ is at or near zero (i.e., at or near normal incidence).

Beam energy monitoring system

In another example embodiment, apparatus 10 includes a beam energy monitoring system 250 arranged along axis A1 downstream of radiation source 12 to monitor the energy in the respective beam. System 250 is coupled to controller 70 via a line 252 and provides to the controller a signal 254 representative of the measured beam energy.

Fold mirror

In another example embodiment, apparatus 10 includes a fold mirror 260 to make the apparatus more compact or to form a particular apparatus geometry. In an example embodiment, fold mirror 260 is movable to adjust the direction of beam 14A'.

Further in an example embodiment, fold mirror 260 is coupled to controller 70 via a line 262 and is controlled by a signal 264 from the controller.

Reflected radiation monitor

With continuing reference to FIG. 3, in another example embodiment, apparatus 10 includes a reflected radiation monitor 280 arranged to receive radiation 281 reflected from substrate surface 62. Monitor 280 is coupled to controller 70 via a line 282 and provides to the controller a signal 284 representative of the amount of reflected radiation 281 it measures.

FIG. 4 illustrates an example embodiment of reflected radiation monitor 280 for an example embodiment of apparatus 10 in which incident angle Φ (FIGS. 1 and 2A) is equal to or near 0° . Reflected radiation monitor 280 utilizes a beamsplitter 285 along axis A1 to direct a small portion of the reflected radiation 281 (FIG. 3) to a detector 287. Monitor 280 is coupled to controller 70 via line 282 and provides to the controller a signal 284

representative of the detected radiation. In an example embodiment, a focusing lens 290 is included to focus reflected radiation 281 onto detector 287.

Reflected radiation monitor 280 has several applications. In one mode of operation, image 100 is made as small as possible and the variation in the reflected radiation monitor signal 284 is measured. This information is then used to assess the variation in reflectivity across the substrate. This mode of operation requires that the response time of the detector (e.g., detector 287) be equal to less than the dwell time of the scanned beam. The variation in reflectivity is minimized by adjusting incident angle ϕ , by adjusting the polarization direction of incident beam 14B, or both.

In a second mode of operation, beam energy monitoring signal 254 (FIG. 3) from beam energy monitoring system 250, and the radiation monitoring signal 284 are combined to yield an accurate measure of the amount of absorbed radiation. The energy in radiation beam 14B is then adjusted to maintain the absorbed radiation at a constant level. A variation of this mode of operation involves adjusting the scanning velocity in a manner corresponding to the absorbed radiation.

In a third mode of operation, the reflected radiation monitor signal 284 is compared to a threshold, and a signal above the threshold is used as a warning that an unexpected anomaly has occurred that requires further investigation. In an example embodiment, data relating to the variation in reflected radiation is archived (e.g., stored in memory in controller 70), along with the corresponding substrate identification code, to assist in determining the root cause of any anomalies found after substrate processing is completed.

Diagnostic system

In many thermal processes it is advantageous to know the maximum temperature or the temperature-time profile of the surface being treated. For example, in the case of junction annealing, it is desirable to very closely control the maximum temperature reached during LTP. Close control is achieved by using the measured temperature to control the output power of the continuous radiation source. Ideally, such a control system would have a response capability that is faster than, or about as fast as, the dwell time of the scanned image.

Accordingly, with reference again to FIG. 3, in another example embodiment, apparatus 10 includes a diagnostic system 300 in communication with substrate 60. Diagnostic system 300 is coupled to controller 70 via a line 302 and is adapted to perform certain diagnostic operations, such as measuring the temperature of substrate 62. Diagnostic system 300 provides to the controller a signal 304 representative of a diagnostic measurement, such as substrate temperature.

With reference again to FIG. 4, when incident angle Φ is equal to or near 0° , diagnostic system 300 is rotated out of the way of focusing optical system 20.

FIG. 5 is a close-up view of an example embodiment of diagnostic system 300 used to measure the temperature at or near the location of scanned image 100. System 300 of FIG. 5 includes along an axis A2 collection optics 340 to collect emitted radiation 310, and a beam splitter 346 for splitting collected radiation 310 and directing the radiation to two detectors 350A and 350B each connected to controller 70 via respective lines 302A and 302B. Detectors 350A and 350B detect different spectral bands of radiation 310.

A very simple configuration for diagnostic system 300 includes a single detector, such as a silicon detector 350A, aimed so that it observes the hottest spot at the trailing edge of the radiation beam (FIG. 3). In general, signal 304 from such a detector will vary because the different films (not shown) on the substrate that image 100 encounters have different reflectivities. For example, silicon, silicon oxide and a thin poly-silicon film over an oxide layer all have different reflectivities at normal incidence and consequently different thermal emissivities.

One way of coping with this problem is to use only the highest signal obtained over a given period of time to estimate the temperature. This approach improves accuracy at the cost of reducing the response time of the detector.

With continuing reference to FIG. 5, in an example embodiment, collection optics 340 is focused on the trailing edge of image 100 (moving in the direction indicated by arrow 354) to collect emitted radiation 310 from the hottest points on substrate 60. Thus, the hottest (i.e., highest) temperature on substrate 60 can be monitored and controlled directly. Control of the substrate temperature can be accomplished in a number of ways, including by varying the power of continuous radiation source 12, by adjusting attenuator 226 (FIG. 3), by varying the substrate scanning speed or the image scanning speed, or any combination thereof.

The temperature of substrate 60 can be gauged by monitoring emitted radiation 310 at a single wavelength, provided the entire surface 62 has the same emissivity. If surface 62 is patterned, then the temperature can be gauged by monitoring the ratio between two closely spaced wavelengths during the scanning operation, assuming the emissivity does not change rapidly with wavelength.

FIG. 6 is the black body temperature profile (plot) of the intensity versus wavelength for a temperature of 1410°C, which temperature would be the upper limit to be used in certain thermal processing applications to activate dopants in the source and drain regions of a semiconductor transistor, i.e., regions 66A and 66B of transistor 67 (FIG. 3). As can be seen from FIG. 6, a temperature approaching 1410°C might be monitored at 0.8 microns and 1.0 microns using detectors 350A and 350B in the form of silicon detector arrays. An advantage of using detector arrays as compared to single detectors is that the former allows many temperature samples to be taken along and across image 100 so that any temperature

non-uniformities or irregularities can be quickly spotted. In an example embodiment involving the activation of dopants in source and drain regions 66A and 66B, the temperature needs to be raised to 1400°C with a point-to-point maximum temperature variation of less than 10°C.

5 For temperature control in the 1400°C region, the two spectral regions might be from 500nm to 800nm and from 800nm to 1100nm. The ratio of the signals from the two detectors can be accurately related to temperature, assuming that the emissivity ratios for the two spectral regions does not vary appreciably for the various materials on the substrate surface. Using a ratio of the signals 304A and 304B from silicon detectors 350A and 350B
10 for temperature control makes it relatively easy to achieve a control-loop bandwidth having a response time roughly equal to the dwell time.

An alternate approach is to employ detectors 350A and 350B in the form of detector arrays, where both arrays image the same region of the substrate but employ different spectral regions. This arrangement permits a temperature profile of the treated area to be
15 obtained and both the maximum temperature and the temperature uniformity to be accurately assessed. This arrangement also permits uniformity adjustments to the intensity profile. Employing silicon detectors in such an arrangement allows for a control-loop bandwidth having a response time roughly equal to the dwell time.

Another method to compensate for the varying emissivity of the films encountered
20 on the substrate is to arrange diagnostic system 300 such that it views substrate surface 62 at an angle close to Brewster's angle for silicon using p-polarized radiation. In this case, Brewster's angle is calculated for a wavelength corresponding to the wavelength sensed by diagnostic system 300. Since the absorption coefficient is very nearly unity at Brewster's angle, so also is the emissivity. In an example embodiment, this method is combined with
25 the methods of taking signal ratios at two adjacent wavelengths using two detector arrays. In this case, the plane containing the viewing axis of diagnostic system 300 would be at right angles to the plane 440 containing the radiation beam 14B and the reflected radiation 281, as illustrated in Figure 7.

Scanned image 100 can produce uniform heating over a large portion of the
30 substrate. However, diffraction, as well as a number of possible defects in the optical train, can interfere with the formation of the image and cause an unanticipated result, such as non-uniform heating. Thus, it is highly desirable to have a built-in image monitoring system that can directly measure the energy uniformity in the image.

An example embodiment of an image monitoring system 360 is illustrated in FIG 5.
35 In an example embodiment, image monitoring system 360 is arranged in the scanning path and in the plane PS defined by substrate surface 62. Image monitoring system 360 includes a pinhole 362 oriented in the scan path, and a detector 364 behind the pinhole. In operation,

substrate stage 46 is positioned so that detector 364 samples image 100 representative of what a point on the substrate might see during a typical scan of the image. Image monitoring system 360 is connected to controller 70 via a line 366 and provides a signal 368 to the controller representative of the detected radiation.

5 Sampling portions of the image provides the data necessary for the image intensity profile (e.g., FIG. 1C) to be determined, which in turn allows for the heating uniformity of the substrate to be determined.

Substrate pre-aligner

10 With reference again to FIG. 3, in certain instances, substrate 60 needs to be placed on chuck 40 in a predetermined orientation. For example, substrate 60 can be crystalline (e.g., a crystalline silicon wafer). The inventors have found that in thermal processing applications utilizing crystalline substrates it is often preferred that the crystal axes be aligned in a select direction relative to image 100 to optimize processing.

15 Accordingly, in an example embodiment, apparatus 10 includes a pre-aligner 376 coupled to controller 70 via a line 378. Pre-aligner 376 receives a substrate 60 and aligns it to a reference position P_R by locating reference feature 64, such as a flat or a notch, and moving (e.g., rotating) the substrate until the reference feature aligns with the select direction to optimize processing. A signal 380 is sent to controller 70 when the substrate is aligned. The substrate is then delivered from the pre-aligner to chuck 40 via a substrate
20 handler 386, which is in operative communication with the chuck and pre-aligner 376. Substrate handler is coupled to controller 70 via a line 388 and is controlled via a signal 390. Substrate 60 is then placed on chuck 40 in a select orientation corresponding to the orientation of the substrate as pre-aligned on pre-aligner 376.

Measuring the absorbed radiation

25 By measuring the energy in one of radiation beams 14A, 14A' or 14B using beam energy monitoring system 250, and from measuring the energy in reflected radiation 281 using monitoring system 280, the radiation absorbed by substrate 60 can be determined. This in turn allows the radiation absorbed by substrate 60 to be maintained constant during scanning despite changes in the reflectance of substrate surface 62. In an example
30 embodiment, maintaining a constant energy absorption per unit area is accomplished by adjusting one or more of the following: the output power of continuous radiation source 12; the scanning speed of image 100 over substrate surface 62; and the degree of attenuation of attenuator 226.

In an example embodiment, constant energy absorption per unit area is achieved by
35 varying the polarization of radiation beam 14B, such as by rotating quarter wave plate 230. In another example embodiment, the energy absorbed per unit area is varied or maintained constant by any combination of the above mentioned techniques. The absorption in silicon of

select infrared wavelengths is substantially increased by dopant impurities that improve the electrical conductivity of the silicon. Even if minimal absorption of the incident radiation is achieved at room temperature, any increase in temperature increases the absorption, thereby producing a runaway cycle that quickly results in all the incident energy being absorbed in a surface layer only a few microns deep.

Thus, the heating depth in a silicon wafer is determined primarily by diffusion of heat from the surface of the silicon rather than by the room-temperature absorption depth of the infrared wavelengths. Also, doping of the silicon with n-type or p-type impurities increases the room temperature absorption and further promotes the runaway cycle leading to strong absorption in the first few microns of material.

Incident angle at or near Brewster's angle

In an example embodiment, incident angle ϕ is set to correspond to Brewster's angle. At Brewster's angle all the p-polarized radiation P (FIG. 3) is absorbed in substrate 60. Brewster's angle depends on the refractive index of the material on which the radiation is incident. For example, Brewster's angle is 73.69° for room temperature silicon and a wavelength $\lambda = 10.6$ microns. Since about 30% of the incident radiation beam 14B is reflected at normal incidence ($\phi = 0$), using p-polarization radiation at or near Brewster's angle can significantly reduce the power per unit area required to perform thermal processing. Using a relatively large incident angle ϕ such as Brewster's angle also broadens the width of image 100 in one direction by $\cos^{-1}\phi$, or by about 3.5 times that of the normal incidence image width. The effective depth of focus of image 100 is also reduced by a like factor.

Where substrate 60 has a surface 62 with a variety of different regions some of which have multiple layers, as is typically the case for semiconductor processing for forming ICs, the optimum angle for processing can be gauged by plotting the reflectivity versus incident angle Φ for the various regions. Generally it will be found that for p-polarized radiation that a minimum reflectivity occurs for every region near Brewster's angle for the substrate. Usually an angle, or a small range of angles, can be found that both minimizes and equalizes the reflectivity of each region.

In an example embodiment, incident angle Φ is confined within a range of angles surrounding Brewster's angle. For the example above where Brewster's angle is 73.69° , the incident angle ϕ may be constrained between 65° and 80° .

Optimizing the radiation beam geometry

Thermally processing substrate 60 by scanning image 100 over surface 62, in an example embodiment, causes a very small volume of material at the substrate surface to be heated close to the melting point of the substrate. Accordingly, a substantial amount of stress and strain is created in the heated portion of the substrate. Under some conditions,

this stress results in the creation of undesirable slip planes that propagate to surface 62.

Also, in an example embodiment radiation beam 14A is polarized. In such a case, it is practical to choose the direction of polarization of the incident radiation beam 14B relative to substrate surface 62, as well as the direction of radiation beam 14B incident on surface 62 that results in the most efficient processing. Further, thermal processing of substrate 60 is often performed after the substrate has been through a number of other processes that alter the substrate properties, including the structure and topography.

FIG. 7 is a close-up isometric view of an example substrate 60 in the form of a semiconductor wafer having a pattern 400 formed thereon. In an example embodiment, pattern 400 contains lines or edges 404 and 406 conforming to a grid (i.e., a Manhattan geometry) with the lines/edges running in the X- and Y-directions. Lines/edges 404 and 406 correspond, for example, to the edges of poly-runners, gates and field oxide isolation regions, or IC chip boundaries. Generally speaking, in IC chip manufacturing the substrate is patterned mostly with features running at right angles to one another.

Thus, for example, by the time substrate (wafer) 60 has reached the point in the process of forming an IC chip where annealing or activation of the source and drain regions 66A and 66B is required, surface 62 is quite complex. For example, in a typical IC manufacturing process, a region of surface 62 may be bare silicon, while another region of the surface may have a relatively thick silicon oxide isolation trench, while yet other regions of the surface may have a thin polysilicon conductor traversing the thick oxide trench.

Accordingly, if care is not taken, line image 100 can be reflected or diffracted from some sections of substrate surface 62, and can be selectively absorbed in others, depending on the surface structure, including the dominant direction of the lines/edges 404 and 406. This is particularly true in the embodiment where radiation beam 14B is polarized. The result is non-uniform substrate heating, which is generally undesirable in thermal processing.

Thus, with continuing reference to FIG. 7, in an example embodiment of the invention, it is desirable to find an optimum radiation beam geometry, i.e., a polarization direction, an incident angle ϕ , a scan direction, a scan speed, and an image angle θ , that minimizes variations in the absorption of radiation beam 14B in substrate 60. It is further desirable to find the radiation beam geometry that minimizes the formation of slip planes in the substrate.

Point-to-point variations in radiation 281 reflected from substrate 60 are caused by a number of factors, including film composition variations, the number and proportion of lines/edges 404 and 406, the orientation of the polarization direction, and the incident angle ϕ .

With continuing reference to FIG. 7, a plane 440 is defined as that containing radiation beam 14B and reflected radiation 281. The variation in reflection due to the

presence of lines/edges 404 and 406 can be minimized by irradiating the substrate with radiation beam 14B such that plane 440 intersects substrate surface 62 at 45° to lines/edges 404 and 406. The line image is formed so that its long direction is also either aligned in the same plane 440 or is at right angles to this plane. Thus, regardless of the incident angle ϕ ,
5 the image angle θ between line image 100 and respective lines/edges 404 and 406 is 45° .

The variations in the amount of reflected radiation 281 due to the various structures on substrate surface 62 (e.g., lines/edges 404 and 406) can be further reduced by judiciously selecting incident angle ϕ . For example, in the case of forming a transistor as part of an IC, when a substrate 60 is ready for annealing or activation of source and drain regions 66A and
10 66B, it will typically contain all of the following topographies: a) bare silicon, b) oxide isolators (e.g., about 0.5 microns thick) buried in the silicon, and c) a thin (e.g., 0.1 micron) polysilicon runners on top of buried oxide isolators.

FIG. 8 is sets of plots of the room-temperature reflectivity for both p-polarization P and s-polarization S for a 10.6 micron wavelength laser radiation for each of the above-
15 mentioned topographies atop an undoped silicon substrate, along with the reflectivity for a infinitely deep silicon dioxide layer. It is readily apparent from FIG. 8 that the reflectivity varies greatly depending on the polarization and the incident angle ϕ .

For the p-polarization P (i.e., polarization in plane 440) with incident angles ϕ between about 65° and about 80° , the reflectivity for all four cases is a minimum, and the
20 variation from case to case is also a minimum. Thus, the range of incident angles ϕ from about 65° to about 80° is particularly well suited for apparatus 10 for thermally processing a semiconductor substrate (e.g., activating doped regions formed in a silicon substrate), since it minimizes both the total power required and the point-to-point variation in absorbed radiation.

The presence of dopants or higher temperatures renders the silicon more like a metal
25 and serves to shift the minimum corresponding to Brewster's angle to higher angles and higher reflectivities. Thus, for doped substrates and/or for higher temperatures, the optimum angle will be higher than those corresponding the Brewster's angle at room temperature for undoped material.

FIG. 9 is a top-down isometric view of apparatus 10 used to process a substrate 60
30 in the form of a semiconductor wafer, illustrating operation of the apparatus in an optimum radiation beam geometry. Wafer 60 includes grid pattern 400 formed thereon, with each square 468 in the grid representing, for example, an IC chip (e.g., such as circuit 67 of FIG. 1A). Line image 100 is scanned relative to substrate (wafer) surface 62 in a direction 470
35 that results in an image angle θ of 45° .

Accounting for crystal orientation

As mentioned above, crystalline substrates, such as monocrystalline silicon wafers,

have a crystal planes whose orientation is often indicated by reference feature 64 (e.g., a notch as shown in FIG. 9, or a flat) formed in the substrate at edge 63 corresponding to the direction of one of the major crystal planes. The scanning of line image 100 generates large thermal gradients and stress concentrations in a direction 474 normal to scan direction 470 (FIG. 9), which can have an adverse effect on the structural integrity of a crystalline substrate.

With continuing reference to FIG. 9, the usual case is for a silicon substrate 60 having a (100) crystal orientation and lines/edges 404 and 406 aligned at 45° to the two principle crystal axes (100) and (010) on the surface on the wafer. A preferred scan direction is along one of the principle crystal axes to minimize the formation of slip planes in the crystal. Thus the preferred scan direction for minimizing slip generation in the crystal also coincides with the preferred direction with respect to lines/edges 404 and 406 in the usual case for a silicon substrate. If a constant orientation is to be maintained between line image 100, lines/edges 404 and 406, and the crystal axes (100) and (010), then the scanning of the line image with respect to the substrate (wafer) 60 must be performed in a linear (e.g., back and forth) fashion rather than in a circular or arcuate fashion. Also, since a specific scan direction is desired with respect to the crystal orientation, in an example embodiment the substrate is pre-aligned on chuck 40 using, for example, substrate pre-aligner 376 (FIG. 3).

By carefully choosing the orientation between the substrate crystal axes (100) and (010) and scan direction 470, it is possible to minimize the likelihood of producing slip planes in the substrate crystalline lattice due to thermally induced stress. The optimal scan direction wherein the crystal lattice has maximum resistance to slip induced by a steep thermal gradient is believed to vary depending on the nature of the crystal substrate. However, the optimal scan direction can be found experimentally by scanning image 100 in a spiral pattern over a single crystal substrate and inspecting the wafer to determine which directions withstand the highest temperature gradients before exhibiting slip.

In a substrate 60 in the form of a (100) crystal silicon wafer, the optimal scan direction is aligned to the (100) substrate crystal lattice directions or at 45° to the pattern grid directions indicated by lines/edges 404 and 406. This has been experimentally verified by the inventors by scanning a radially-oriented line image 100 in a spiral pattern that gradually increases the maximum temperature as a function of distance from the center of the substrate. The optimal scan direction was determined by comparing the directions exhibiting the greatest immunity to slipping with the directions of the crystal axes.

35 **Image Scanning**

Boustrophedonic scanning

FIG. 10 is a plan view of a substrate illustrating a boustrophedonic (i.e., alternating

back and forth or “X-Y”) scanning pattern 520 of image 100 over substrate surface 62 to generate a short thermal pulse at each point on the substrate traversed by the image.

Scanning pattern 520 includes linear scanning segments 522. Boustrophedonic scanning pattern 520 can be carried out with a conventional bidirectional, X-Y stage 46. However, such stages typically have considerable mass and limited acceleration capability. If a very short dwell time (i.e., the duration the scanned image resides over a given point on the substrate) is desired, then a conventional stage will consume a considerable amount of time accelerating and decelerating. Such a stage also takes up considerable space. For example, a 10 microsecond dwell time with a 100 micron beam width would require a stage velocity of 10 meters/second (m/s). At an acceleration of 1g or 9.8m/s^2 , it would take 1.02 seconds and 5.1 meters of travel to accelerate/decelerate. Providing 10.2 meters of space for the stage to accelerate and decelerate is undesirable.

Optical scanning

The scanning of image 100 over substrate surface 62 may be performed using a stationary substrate and a moving image, by moving the substrate and keeping the image stationary, or a moving both the substrate the image.

FIG. 11 is a cross-sectional view of an example embodiment of an optical system 20 that includes a movable scanning mirror 260. Very high effective acceleration/deceleration rates (i.e., rates at which a stage would need to move to achieve the same scanning effect) can be achieved using optical scanning.

In optical system 20 of FIG. 11, radiation beam 14A (or 14A') is reflected from scanning mirror 260 located at the pupil of an f-theta relay optical system 20 made from cylindrical elements L10 through L13. In an example embodiment, scanning mirror 260 is coupled to and driven by a servo-motor unit 540, which is coupled to controller 70 via line 542. Servo unit 540 is controlled by a signal 544 from controller 70 and carried on line 542.

Optical system 20 scans radiation beam 14B over substrate surface 62 to form a moving line image 100. Stage 46 increments the substrate position in the cross-scan direction after each scan to cover a desired region of the substrate.

In an example embodiment, lens elements L10 through L13 are made of ZnSe and are transparent to both the infrared wavelengths of radiation emitted by a CO₂ laser, and the near-IR and visible radiation emitted by the heated portion of the substrate. This permits a dichroic beam-splitter 550 to be placed in the path of radiation beam 14A upstream of scan mirror 260 to separate the visible and near IR wavelengths of radiation emitted from the substrate from the long wavelength radiation of radiation beam 14A used to heat the substrate.

Emitted radiation 310 is used to monitor and control the thermal processing of the substrate and is detected by a beam diagnostic system 560 having a collection lens 562 and a

detector 564 coupled to controller 70 via line 568. In an example embodiment, emitted radiation 310 is filtered and focused onto separate detector arrays 564 (only one is shown). A signal 570 corresponding to the amount of radiation detected by detector 564 is provided to controller 70 via line 568.

5 Although FIG. 11 shows radiation beam 14B having an incident angle $\phi = 0$, in other embodiments the incident angle is $\phi > 0$. In an example embodiment, incident angle ϕ is changed by appropriately rotating substrate stage 46 about an axis AR.

An advantage of optical scanning is it can be performed at very high speeds so that a minimum amount of time is lost accelerating and decelerating the beam or the stage. With
10 commercially available scanning optical systems, it is possible to achieve the equivalent of an 8000g stage-acceleration.

Spiral scanning

In another example embodiment, image 100 is scanned relative to substrate 60 in a spiral pattern. FIG. 12 is a plan view of four substrates 60 residing on stage 46, wherein the
15 stage has the capability of moving both rotationally and linearly with respect to image 100 to create a spiral scanning pattern 604. The rotational motion is about a center of rotation 610. Also, stage 46 is capable of carrying multiple substrates, with four substrates being shown for the sake of illustration.

In an example embodiment, stage 46 includes a linear stage 612 and a rotational
20 stage 614. Spiral scanning pattern 604 is formed via a combination of linear and rotational motion of the substrates so that each substrate is covered by part of the spiral scanning pattern. To keep the dwell time constant at each point on the substrates, the rotation rate is made inversely proportional to the distance of image 100 from center of rotation 610. Spiral scanning has the advantage that there is no rapid acceleration/deceleration except at the
25 beginning and end of the processing. Accordingly, it is practical to obtain short dwell times with such an arrangement. Another advantage is that multiple substrates can be processed in a single scanning operation.

Alternate raster scanning

Scanning image 100 over substrate 60 in a boustrophedonic pattern with a small
30 separation between adjacent path segments can result in overheating the substrate at the end of a scan segment where one segment has just been completed and a new one is starting right next to it. In such a case, the beginning portion of the new scan path segment contains a significant thermal gradient resulting from the just-completed scan path segment. This gradient raises the temperature produced by the new scan unless the beam intensity is
35 appropriately modified. This makes it difficult to achieve a uniform maximum temperature across the entire substrate during scanning.

FIGS. 13A and 13B are plan views of a substrate 60 illustrating an alternate raster

scanning path 700 having linear scanning path segments 702 and 704. With reference first to FIG. 13A, in the alternate raster scanning path 700, scanning path segments 702 are first carried out so that there is a gap 706 between adjacent scanning paths. In an example embodiment, gap 706 has a dimension equal to some integer multiple of the effective length of the line scan. In an example embodiment, the width of gap 706 is the same as or close to length L1 of image 100. Then, with reference to FIG. 13B, scanning path segments 704 are then carried out to fill in the gaps. This scanning method drastically reduces the thermal gradients in the scan path that arise with closely-spaced, consecutive scan path segments, making it easier to achieve a uniform maximum temperature across the substrate during scanning.

Throughput comparison of scanning patterns

FIG. 14 is a plot of the simulated throughput (substrates/hour) vs. the dwell time (seconds) for the spiral scanning method (curve 720), the optical scanning method (curve 724) and the boustrophedonic (X-Y) scanning method (curve 726). The comparison assumes an example embodiment with a 5kW laser as a continuous radiation source used to produce a Gaussian beam and thus a Gaussian image 100 with a beam width L2 of 100 microns scanned in overlapping scan paths to achieve a radiation uniformity of about $\pm 2\%$.

From the plot, it is seen that the spiral scanning method has better throughput under all conditions. However, the spiral scanning method processes multiple substrates at one time and so requires a large surface capable of supporting 4 chucks. For example, for four 300 mm wafers, the surface would be larger than about 800mm in diameter. Another disadvantage of this method is that it cannot maintain a constant direction between the line scan image and the crystal orientation of the substrate, so that it cannot maintain an optimum processing geometry for a crystalline substrate.

The optical scanning method has a throughput that is almost independent of dwell time and has an advantage over the X-Y stage scanning system for short dwell times requiring high scanning speeds.

The many features and advantages of the present invention are apparent from the detailed specification, and, thus, it is intended by the appended claims to cover all such features and advantages of the described apparatus that follow the true spirit and scope of the invention. Furthermore, since numerous modifications and changes will readily occur to those of skill in the art, it is not desired to limit the invention to the exact construction and operation described herein. Accordingly, other embodiments are within the scope of the appended claims.

What is claimed is:

1. An apparatus to thermally process a region of a substrate, comprising along an axis:
 - 5 a continuous radiation source capable of providing a continuous first radiation beam with a first intensity profile and a wavelength capable of heating the region of the substrate;
 - an optical system adapted to receive the first radiation beam and form a second radiation beam therefrom that forms an image at the substrate; and
 - a stage adapted to support the substrate;
- 10 wherein at least one of the optical system and the stage is adapted to scan the image with respect to the substrate in a scan direction to heat the region with a pulse of radiation to a temperature sufficient to thermally process the region.
 2. The apparatus of claim 1 wherein the image is a line image.
 3. The apparatus of claim 1 wherein the optical system includes one or more
 - 15 curved mirrors.
 4. The apparatus of claim 3 wherein the one or more curved mirrors includes a conical mirror.
 5. The apparatus of claim 4 further including a plurality of conical mirrors each having a different cone angle and selectively positionable in and removable from the first
 - 20 radiation beam to form different sized line images.
 6. The apparatus of claim 3 wherein the first radiation beam has a size, and wherein the one or more mirrors include two or more pairs of parabolic cylindrical mirrors of opposite power arranged in the first radiation beam to change the size and direction of the first radiation beam.
 - 25 7. The apparatus of claim 6 wherein the pairs of parabolic cylindrical mirrors are selectively positionable in and removable from the first radiation beam to alter the size of the first radiation beam.
 8. The apparatus of claim 1 further including a beam converter arranged downstream of the radiation source to receive the first radiation beam and convert the first
 - 30 intensity profile to a second intensity profile.
 9. The apparatus of claim 8 wherein the beam converter and the optical system are combined in a single converter/optical system.
 10. The apparatus of claim 8 wherein the first intensity profile is Gaussian.
 11. The apparatus of claim 8 wherein the second intensity profile is substantially
 - 35 uniform in a direction perpendicular to the scan direction.
 12. The apparatus of claim 1 wherein the continuous radiation source is a laser.
 13. The apparatus of claim 12 wherein the laser is a CO₂ laser.

14. The apparatus of claim 13 wherein the wavelength is between about 9.4 microns and about 10.8 microns.
15. The apparatus of claim 1 further including a stage controller coupled to the stage.
- 5 16. The apparatus of claim 15 further including a controller coupled to at least one of the radiation source, the optical system and the stage controller.
17. The apparatus of claim 1 further including one or more of the following:
an adjustable attenuator arranged downstream of the radiation source;
a quarter waveplate arranged downstream of the radiation source;
10 a fold mirror arranged downstream of the radiation source;
a pre-aligner in communication with the stage and adapted to receive the substrate and align the substrate to a reference position;
a monitor arranged adjacent the stage and positioned to receive and measure radiation reflected from the substrate;
- 15 a diagnostic system arranged adjacent the stage and positioned to receive and measure radiation emitted from the substrate;
a beam energy monitoring system arranged downstream of the radiation source to measure the energy in one of the first and second radiation beams; and
an image monitoring system arranged to measure an intensity profile of the image.
- 20 18. The apparatus of claim 17 wherein the apparatus includes the fold mirror and the fold mirror is movable to scan the image over the substrate.
19. The apparatus of claim 17 wherein the apparatus includes the attenuator, and the attenuator includes an adjustable polarizer.
20. The apparatus of claim 17 wherein the apparatus includes the diagnostic
25 system, and wherein the diagnostic system includes first and second detectors adapted to detect respective first and second spectral bands of the radiation emitted from the substrate to ascertain a maximum temperature of the substrate.
21. The apparatus of claim 1 wherein the optical system includes a scanning mirror adapted to scan the image over the region of the substrate.
- 30 22. The apparatus of claim 1 wherein the first radiation beam is polarized.
23. The apparatus of claim 22 wherein the polarization is circular.
24. The apparatus of claim 1 wherein the axis forms an incident angle ϕ with a normal to the substrate surface, and wherein $0^\circ \leq \phi < 90^\circ$.
25. The apparatus of claim 24 wherein the incident angle ϕ is equal to or near to
35 Brewster's angle, and wherein the second radiation beam is p-polarized relative to the substrate.
26. The apparatus of claim 24 wherein the substrate is a monocrystalline

semiconductor, and the incident angle ϕ is between 50° and 80° .

27. The apparatus of claim 1 wherein the substrate includes a grid pattern, and wherein the image is oriented at a 45° angle with respect to the grid pattern.

28. A method of thermally processing one or more regions of a substrate,
5 comprising the steps of:

a. generating a continuous beam of radiation having a wavelength capable of heating the region; and

b. scanning the radiation over the one or more regions in a scan direction so that each point in the one or more regions receives an amount of thermal energy capable of
10 processing each of the one or more regions.

29. The method of claim 28 wherein the substrate is monocrystalline and step b. is performed such that the image has a dwell-time over each point in the one or more regions of between a microsecond and a millisecond.

30. The method of claim 29 wherein the one or more regions include integrated
15 circuits and the radiation of step b. forms an image having a dimension perpendicular to the scan direction of 1cm or less.

31. The method of claim 28 wherein:
the continuous beam of radiation has a first profile and
further includes the step of:

20 c. modifying the beam of radiation to form a second profile.

32. The method of claim 31 wherein step c. modifies the beam of radiation such that the second profile forms an image having a substantially uniform intensity at the substrate.

33. The method of claim 28 further includes the step of:

25 c. attenuating the beam of radiation to maintain the one or more regions at a select temperature.

34. The method of claim 28 wherein:

the continuous beam of radiation has output power; and
further includes the step of:

30 c. varying the output power to maintain the one or more regions at a select temperature.

35. The method of claim 28 further includes the step of:

c. forming a line image.

36. The method of claim 35 further includes the step of:

35 d. aligning a long dimension of the line image relative to a plane defined by axes associated with incident and reflected beams of radiation.

37. The method of claim 35 further includes the step of:

d. forming the line image by reflecting the beam of radiation from a cone-shaped mirror.

38. The method claim 35 wherein:
the line image has a length L1 and a width L2; and
5 further includes the step of:

d. varying at least one of the length and width.

39. The method of claim 28 further includes the step of:
c. measuring radiation reflected from the region of the substrate.

40. The method of claim 28 further includes the step of:
10 c. measuring the temperature of the region of the substrate.

41. The method of claim 40 wherein step c. includes the step of:
I. measuring radiation emitted from the substrate in two different spectral
bands.

42. The method of claim 40 further includes the steps of:
15 d. imaging a common region of the substrate in different spectral bands with
respective detector arrays; and
e. comparing respective output signals from the detector arrays to determine a
hottest point in the common region and a temperature of the hottest point.

43. The method of claim 28 wherein the beam of radiation is polarized.

20 44. The method of claim 43 further includes the step of:
c. rotating the polarization of the beam of radiation by one-quarter wavelength.

45. The method of claim 43 further includes the step of:
c. altering the polarization of a first beam of radiation to form a circularly
polarized beam of radiation.

25 46. The method of claim 28 wherein:
the beam of radiation is p-polarized with respect to the substrate; and
further includes the step of:

c. irradiating the substrate with the beam of radiation at an angle equal
to or near Brewster's angle.

30 47. The method of claim 28 wherein:
the substrate is a monocrystalline semiconductor;
the beam of radiation is p-polarized; and
further includes the step of:

35 c. irradiating the substrate with the beam of radiation at an incident
angle of between 50° and 80°.

48. The method of claim 28 wherein step b. is performed in one of a
boustrophedonic pattern, a spiral pattern, and an alternating raster pattern.

49. The method of claim 28 further includes the step of:

c. varying the polarization of a first beam of radiation to maintain the substrate at a select temperature.

50. The method of claim 28 wherein step b. is performed at a varying speed to
5 maintain the substrate at a select temperature.

51. The method of claim 28 wherein the wavelength of the first beam of radiation is between 9.4 and 10.8 microns inclusive.

52. The method of claim 28 wherein step b., to minimize variations in radiation reflected from the substrate, includes the steps of:

- 10 i. scanning the beam of continuous radiation over the substrate;
ii. measuring a variation in the reflected radiation over a range of incident angles of a continuous first beam of radiation to determine an optimum incident angle corresponding to a least variation in the amount of reflected radiation; and
iii. scanning at or near the optimum incident angle to thermally process the one
15 or more regions.

53. The method of claim 28 wherein step b., to minimize variations in maximum temperature produced on the substrate, includes the steps or:

- i. forming an image from the continuous beam of radiation;
ii. scanning the image over the substrate;
20 iii. measuring a variation in maximum temperature produced at different locations on the substrate for each incident angle over a range of incidence angles to determine an optimum incident angle corresponding to the least amount of maximum temperature variation; and
iv. scanning at or near the optimum angle to thermally process the one or more
25 regions.

54. The method of claim 28 wherein:

the substrate is crystalline; and

step b. scans the image in a direction that minimizes the formation of slip planes in the substrate.

30 55. The method of claim 54 wherein:

the substrate has crystal axes; and

step b. scans the image in a direction along one of the crystal axes.

56. The method of claim 28 wherein:

the one or more regions include patterned features; and

35 further includes the steps of:

- c. forming a line image with the continuous beam of radiation; and
d. irradiating the substrate with the continuous radiation beam at an incident

angle and with the line image at an image angle relative to the patterned features.

57. The method of claim 56, wherein the incident angle and image angle are selected to minimize temperature variations over the one or more regions.

58. The method of claim 57 wherein:
5 the substrate is crystalline; and
further includes the step of:
e. selecting the scan direction to minimize the formation of slip planes in the substrate.

59. The apparatus of claim 17 wherein the diagnostic system includes a detector
10 positioned to view the heated substrate at Brewster's angle for the wavelength used by the detector and films present on the substrate.

60. The apparatus of claim 59 wherein the diagnostic system receives and measures radiation having a wavelength between 0.5 microns and 0.8 microns.

61. The apparatus of claim 59 wherein the diagnostic system receives and
15 measures radiation having a wavelength between 3 microns and 11 microns.

62. The apparatus of claim 17 wherein the diagnostic system includes a detector array positioned to view the heated substrate at Brewster's angle for the wavelength used by the detector array and films present on the substrate.

63. The apparatus of claim 62 wherein the diagnostic system receives and
20 measures radiation having a wavelength between 0.5 microns and 0.8 microns.

64. The apparatus of claim 62 wherein the diagnostic system receives and measures radiation having a wavelength between 3 microns and 11 microns.

65. The apparatus of claim 1 further includes:
beam forming system to reduce the radiation beam on the substrate to a small size;
25 a radiation monitor adjacent the stage and positioned to receive and measure radiation reflected from the substrate; and
a scanning system adapted to scan the small sized radiation beam over the substrate in a limited area that contains one or more chips so the radiation monitor receives radiation indicative of the reflectivity variation over the limited area.

30 66. The apparatus of claim 1 further includes:
beam forming system to reduce the radiation beam on the substrate a small size incident on the substrate at Brewster's angle for films present on the substrate;
a radiation monitor adjacent the stage and positioned to receive and measure radiation reflected from the substrate; and
35 a scanning system adapted to scan the small sized radiation beam over the substrate in a limited area that contains one or more chips so the radiation monitor receives radiation indicative of the reflectivity variation over the limited area.

67. The apparatus of claim 1 further includes:
a diagnostic system having:
a detector positioned to view the heated region of the substrate at Brewster's angle for the wavelength used by the detector and the films present on the substrate; and
a scanning system to scan the second radiation beam over the substrate in a limited area that contains one or more chips so the detector receives radiation indicative of the temperature variation produced by the second radiation beam as it is scanned over the substrate limited area.
68. The apparatus of claim 67 wherein the diagnostic system employs a wavelength between 0.5 microns and 0.8 microns.
69. The apparatus of claim 67 wherein the diagnostic system employs a wavelength between 3 microns and 11 microns.
70. The apparatus of claim 1 further includes:
a diagnostic system having:
a detector positioned to view the heated region of the substrate at Brewster's angle for the wavelength used by the detector and the films present on the substrate: and
a scanning system to scan the second radiation beam over the substrate in a limited area that contains one or more chips at Brewster's angle for the wavelength of the second radiation beam and the films present on the substrate so the detector receives radiation indicative of the temperature variation produced by the second radiation beam as it scans the substrate limited area.
71. The apparatus of claim 70 wherein the diagnostic system employs a wavelength between 0.5 microns and 0.8 microns.
72. The apparatus of claim 70 wherein the diagnostic system employs a wavelength between 3 microns and 11 microns.
73. The apparatus of claim 1 further includes:
a diagnostic system having:
a detector array positioned to view the heated region of the substrate at Brewster's angle for the wavelength used by the detector and the films present on the substrate; and
a scanning system to scan the second radiation beam over the substrate in a limited area that contains one or more chips so the detector receives radiation indicative of the temperature variation produced by the second radiation beam as it is scanned over the limited area.

74. The apparatus of claim 1 further includes:

beam positioning system to direct the second radiation beam to be incident the substrate at Brewster's angle for the films present on the substrate: and
a diagnostic system having:

5 a detector array positioned to view the heated region of the substrate at Brewster's angle for the wavelength used by the detector and the films present on the substrate; and

a scanning system to scan the second radiation beam over the substrate in a limited area that contains one or more chips so that the detector
10 receives radiation indicative of the temperature variation produced by the second radiation beam as it is scanned over the substrate limited area.

75. The method of claim 46 wherein the beam of radiation is generated by an array of laser diodes.

76. The method of claim 75 wherein the wavelength of the beam of radiation
15 from the diode array is between 0.6 microns and 1.5 microns.

2/20

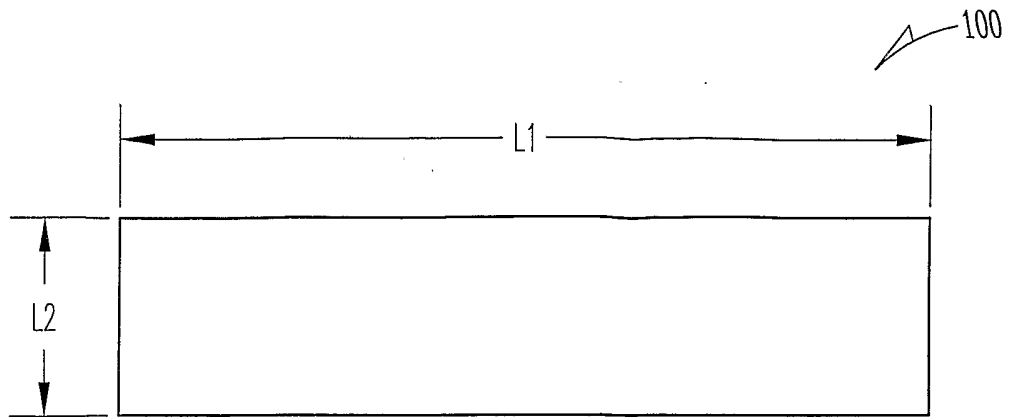

Fig. 1B

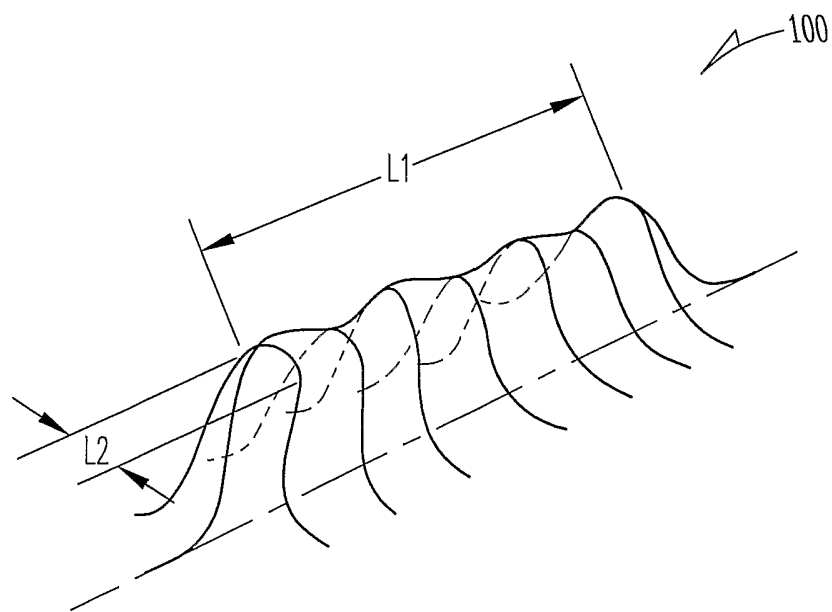

Fig. 1C

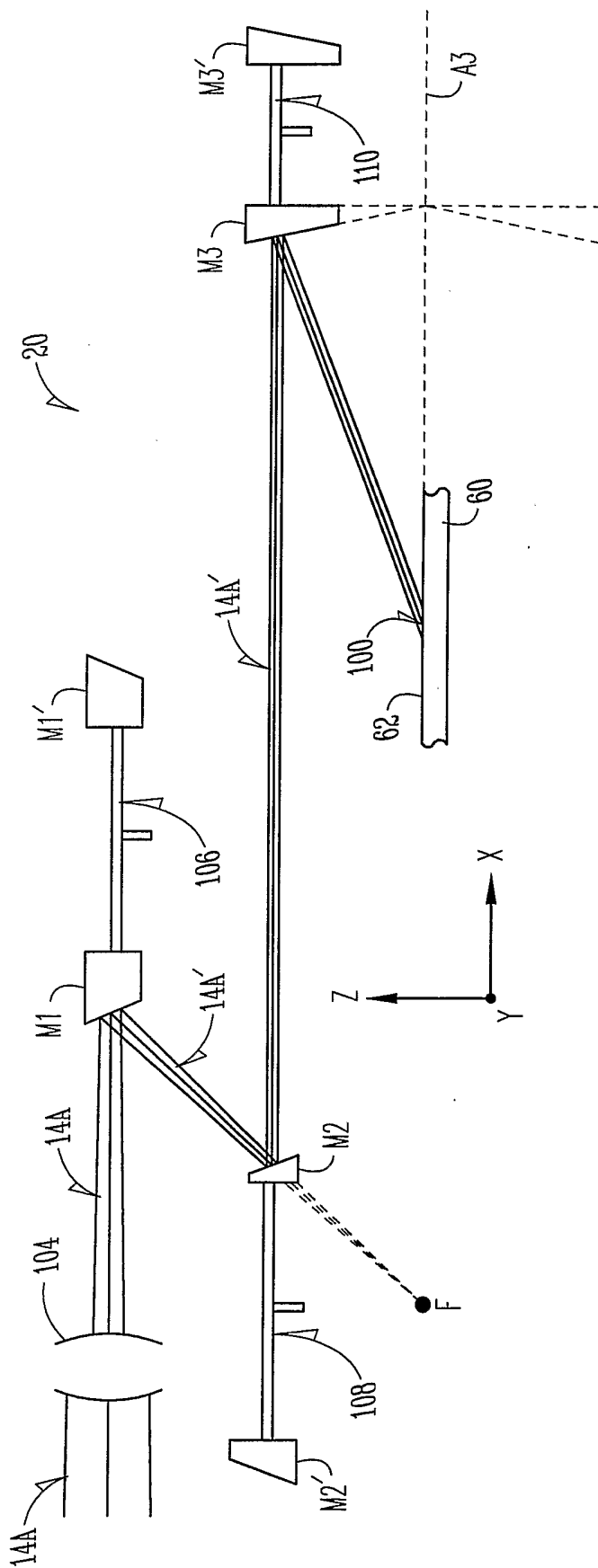

Fig. 1D

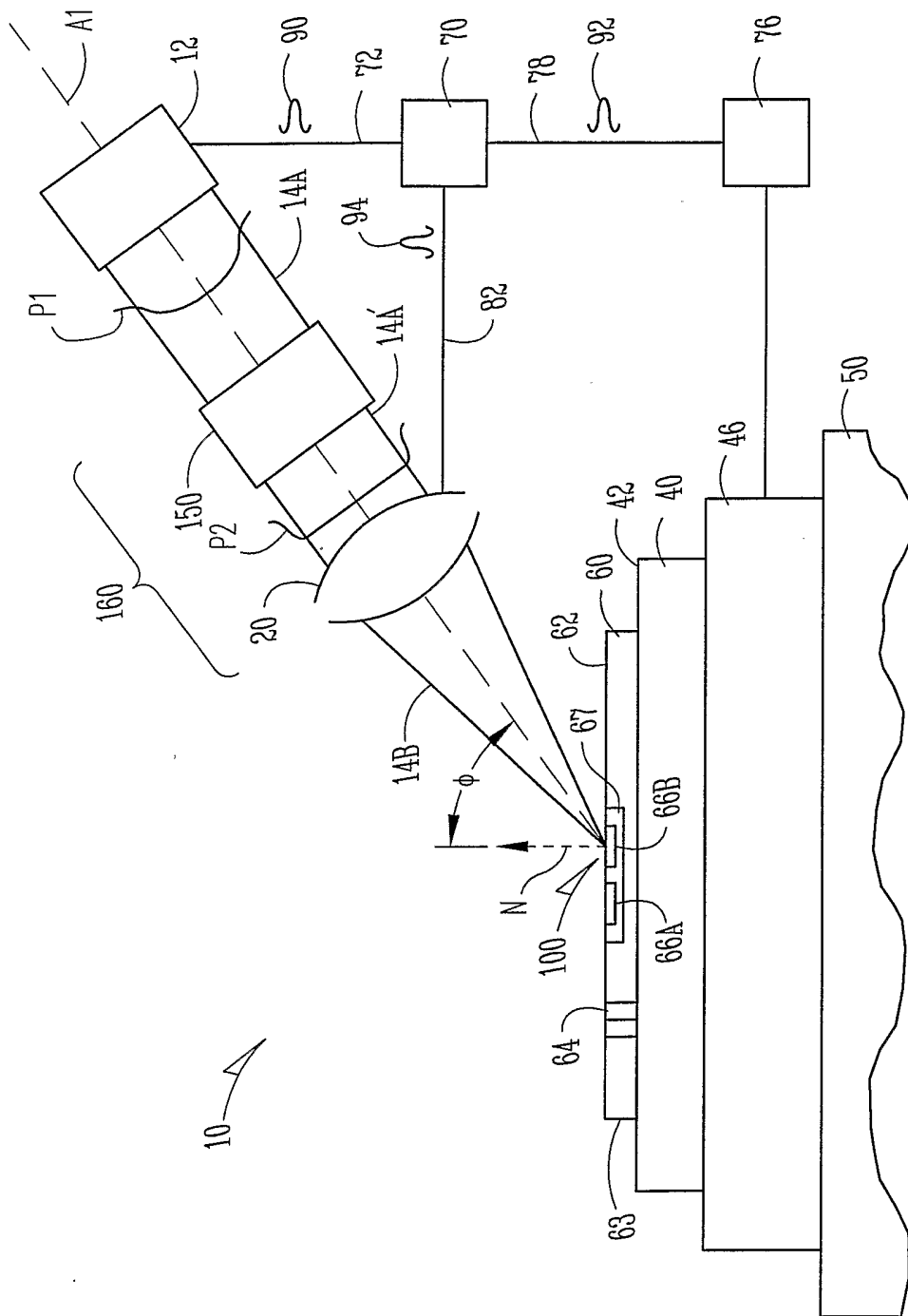

Fig. 2A

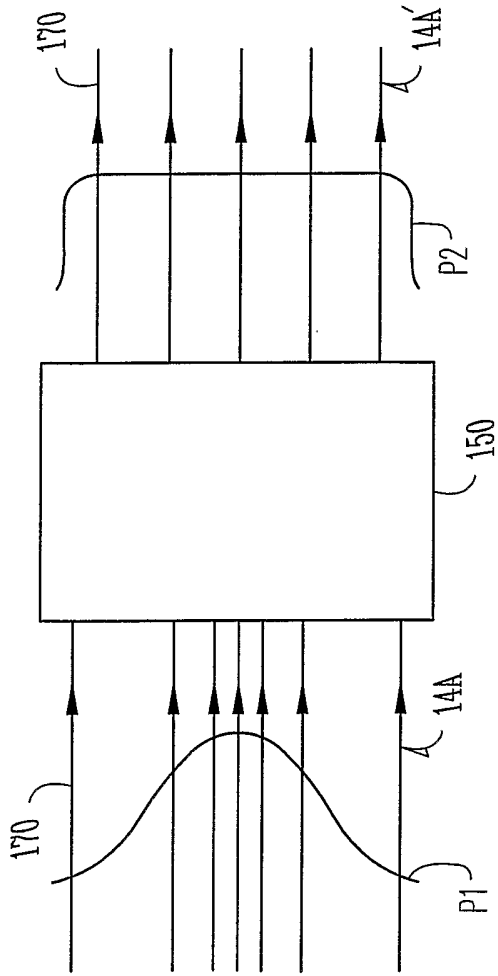

Fig. 2B

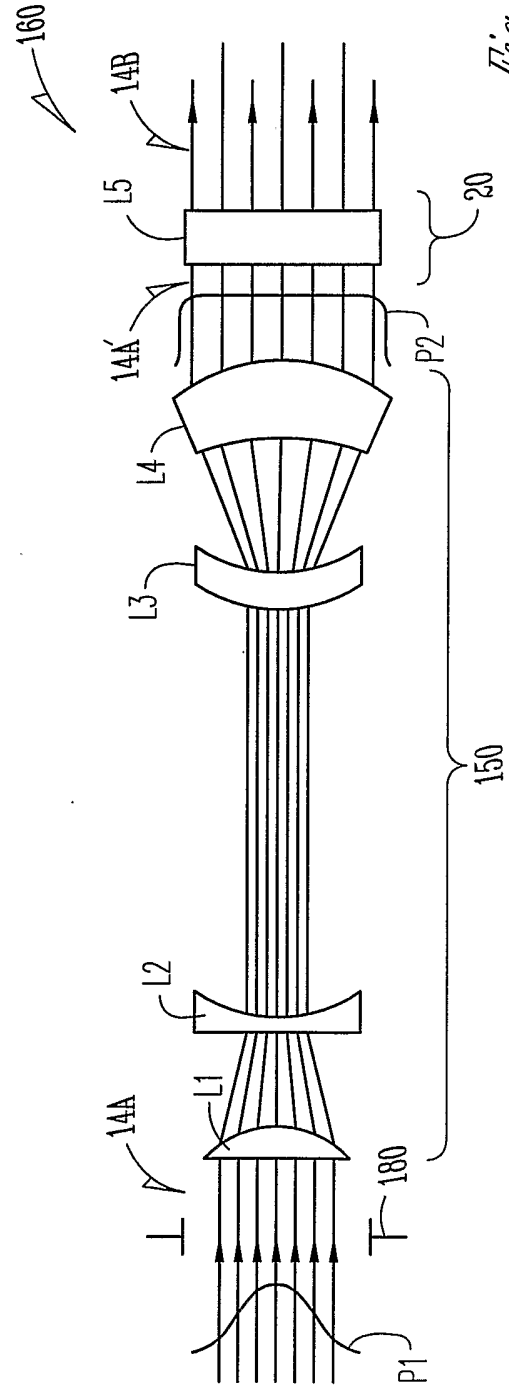

Fig. 2C

6/20

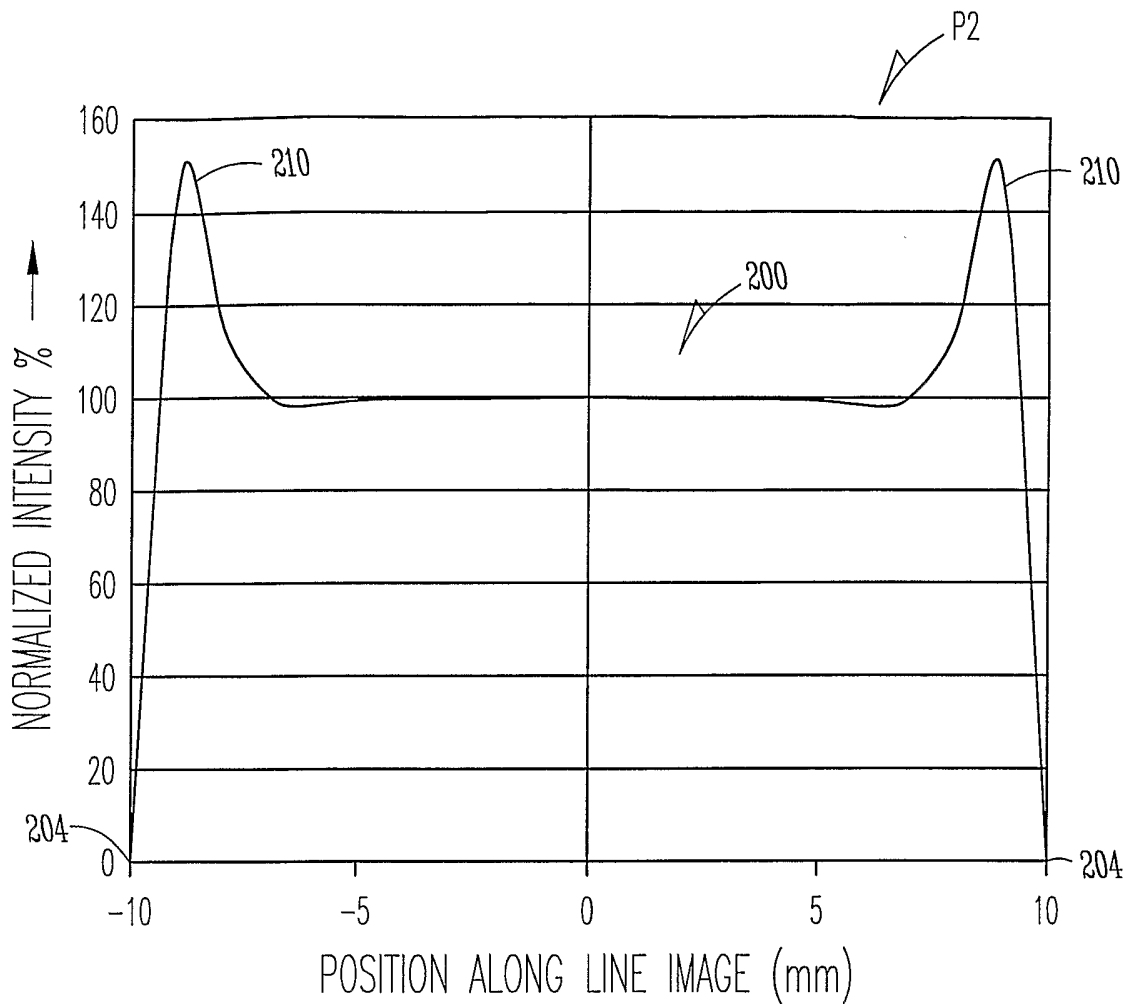

Fig. 2D

7/20

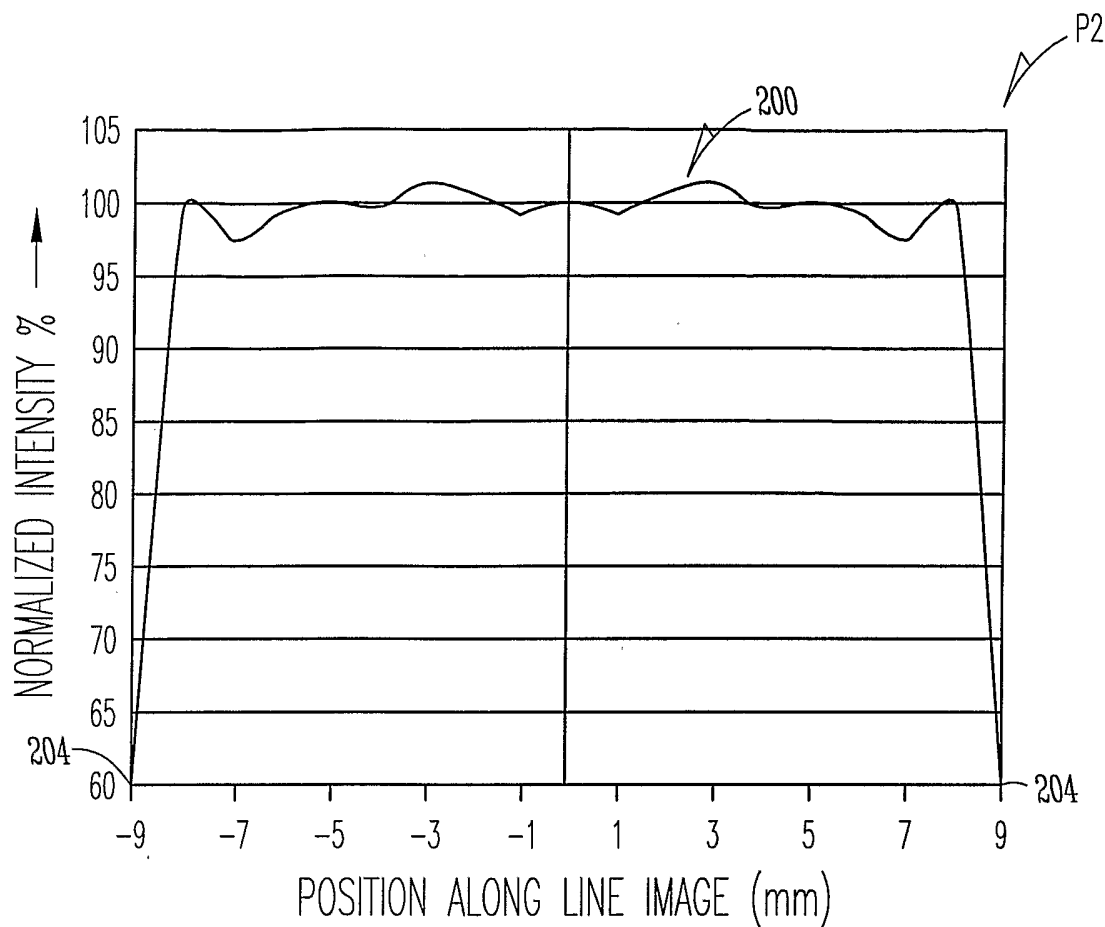

Fig. 2E

9/20

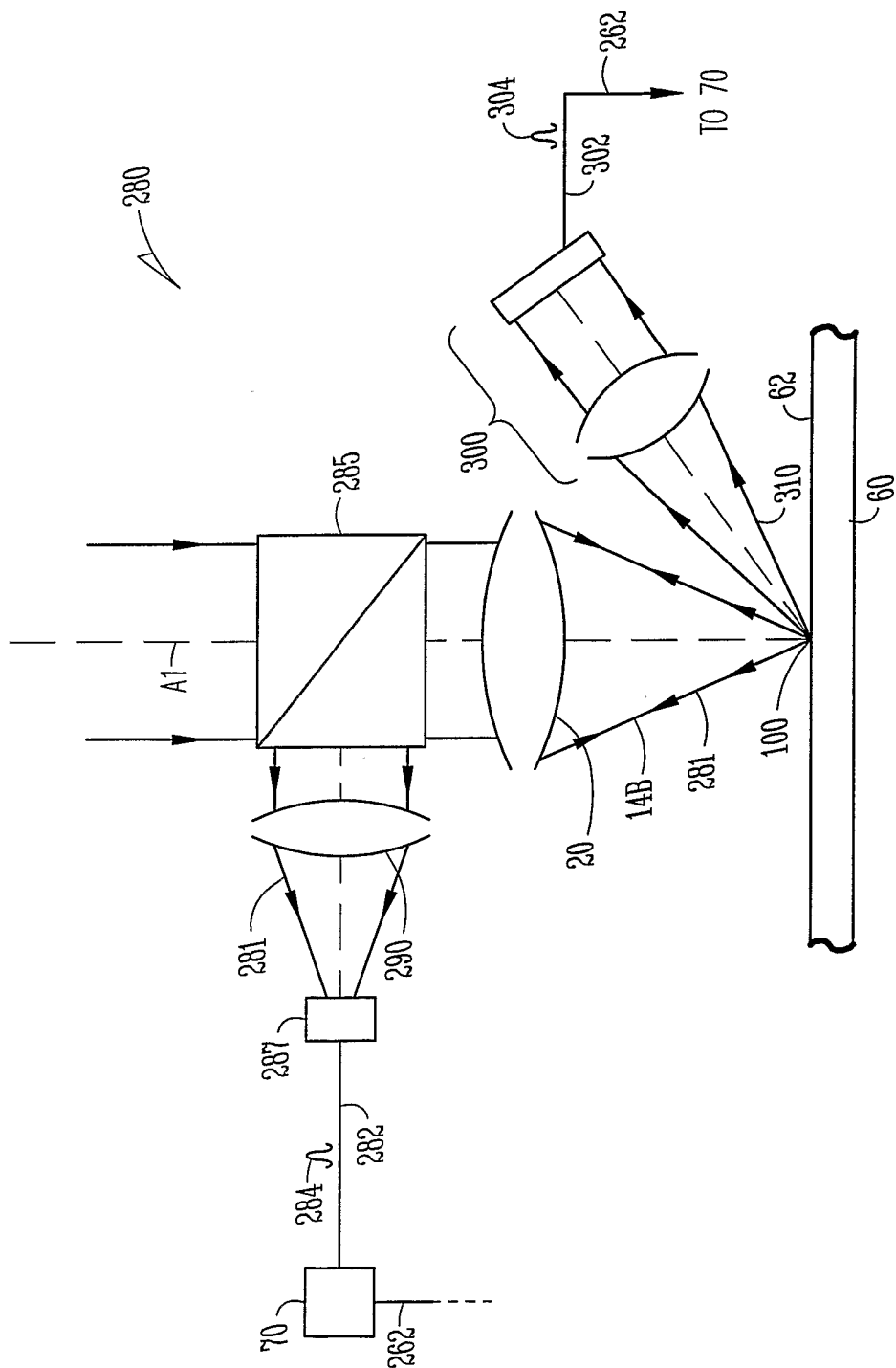

Fig. 4

11/20

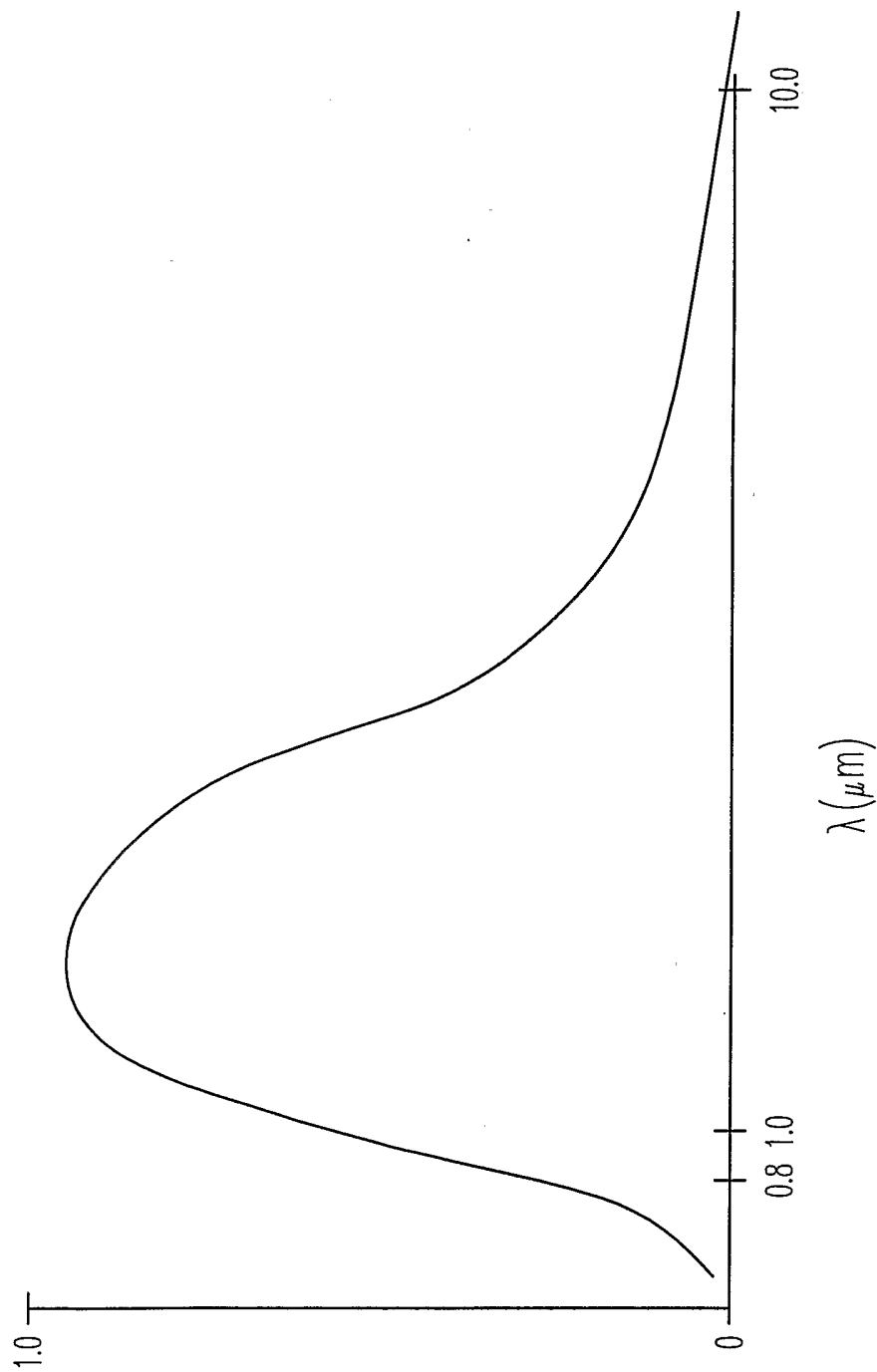

Fig. 6

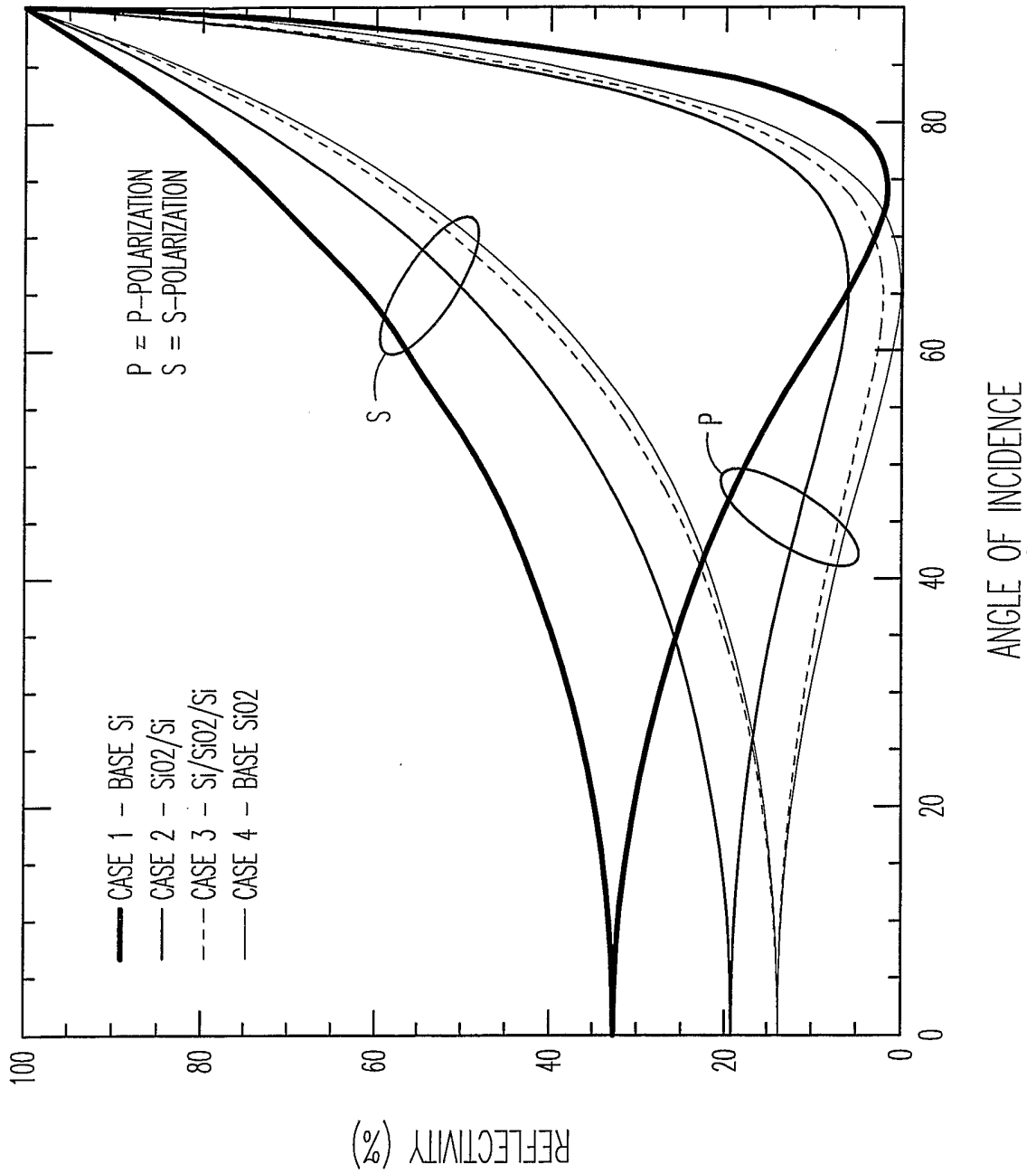

Fig. 8

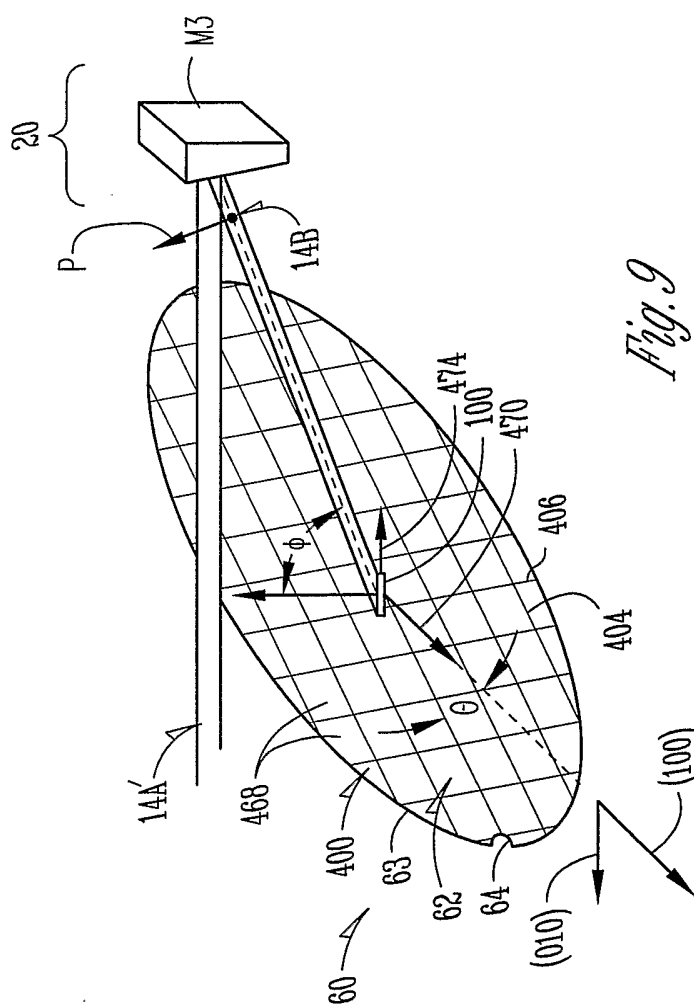

Fig. 9

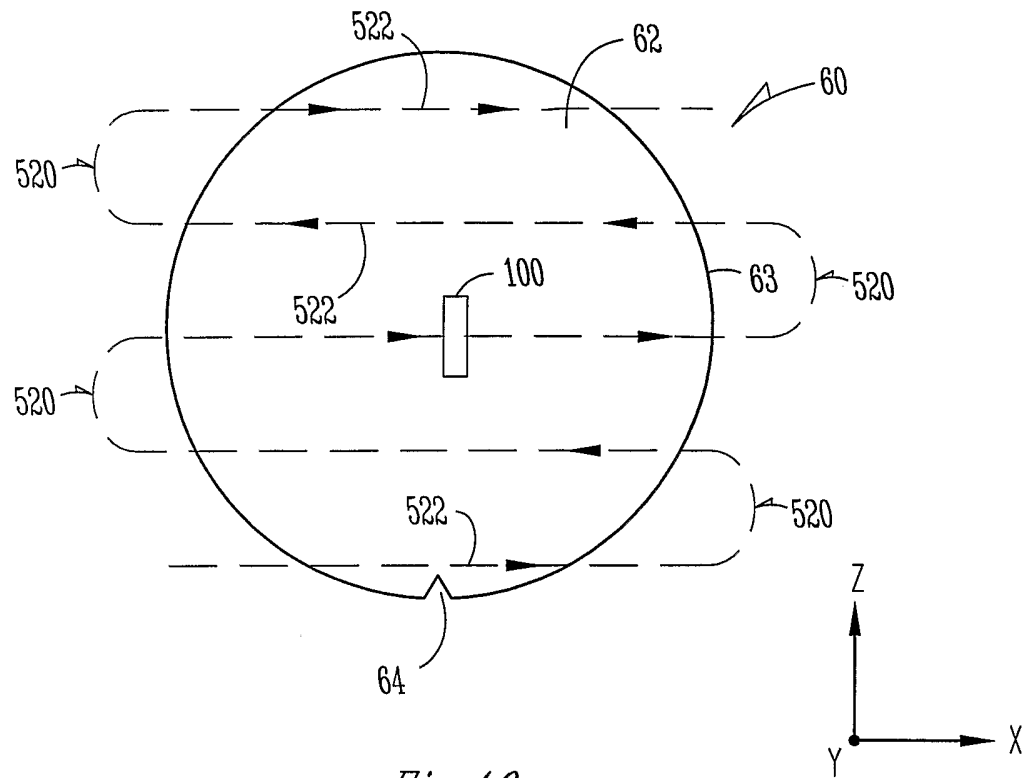

Fig. 10

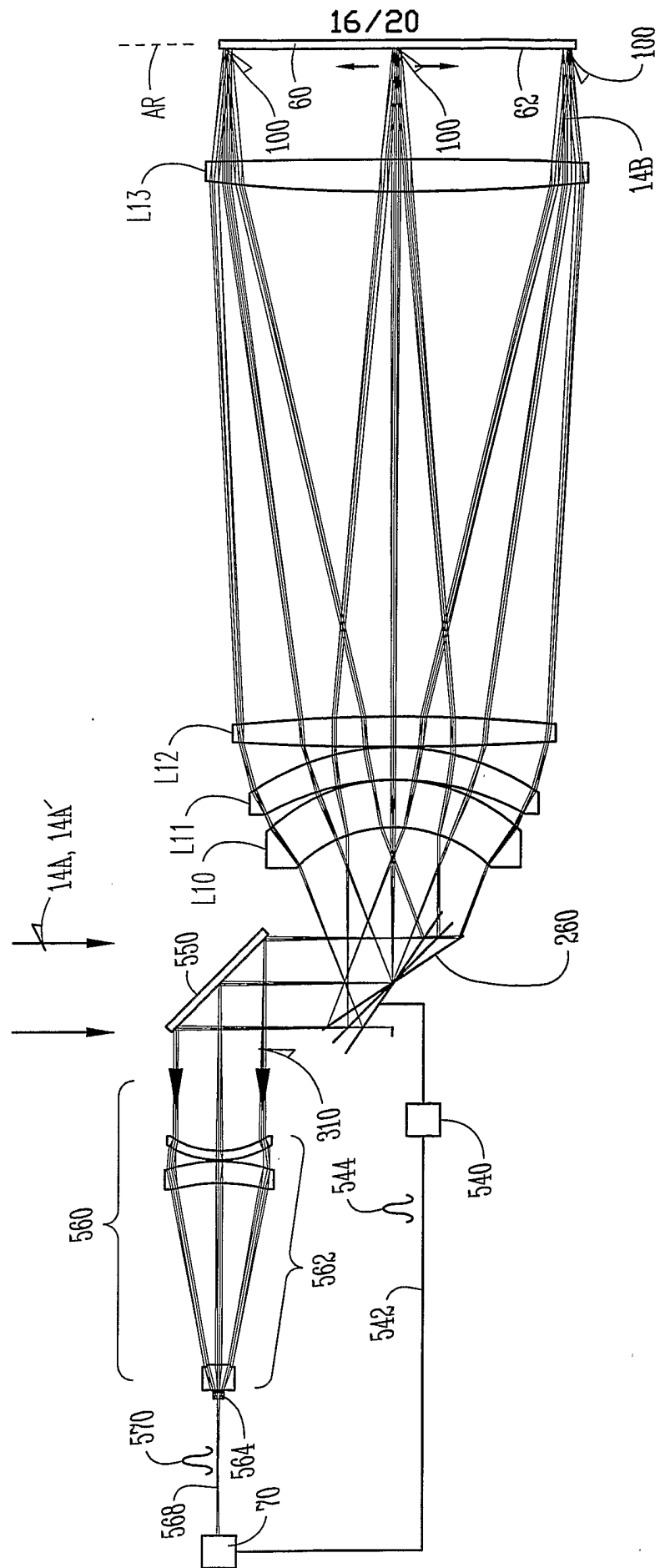

Fig. 11

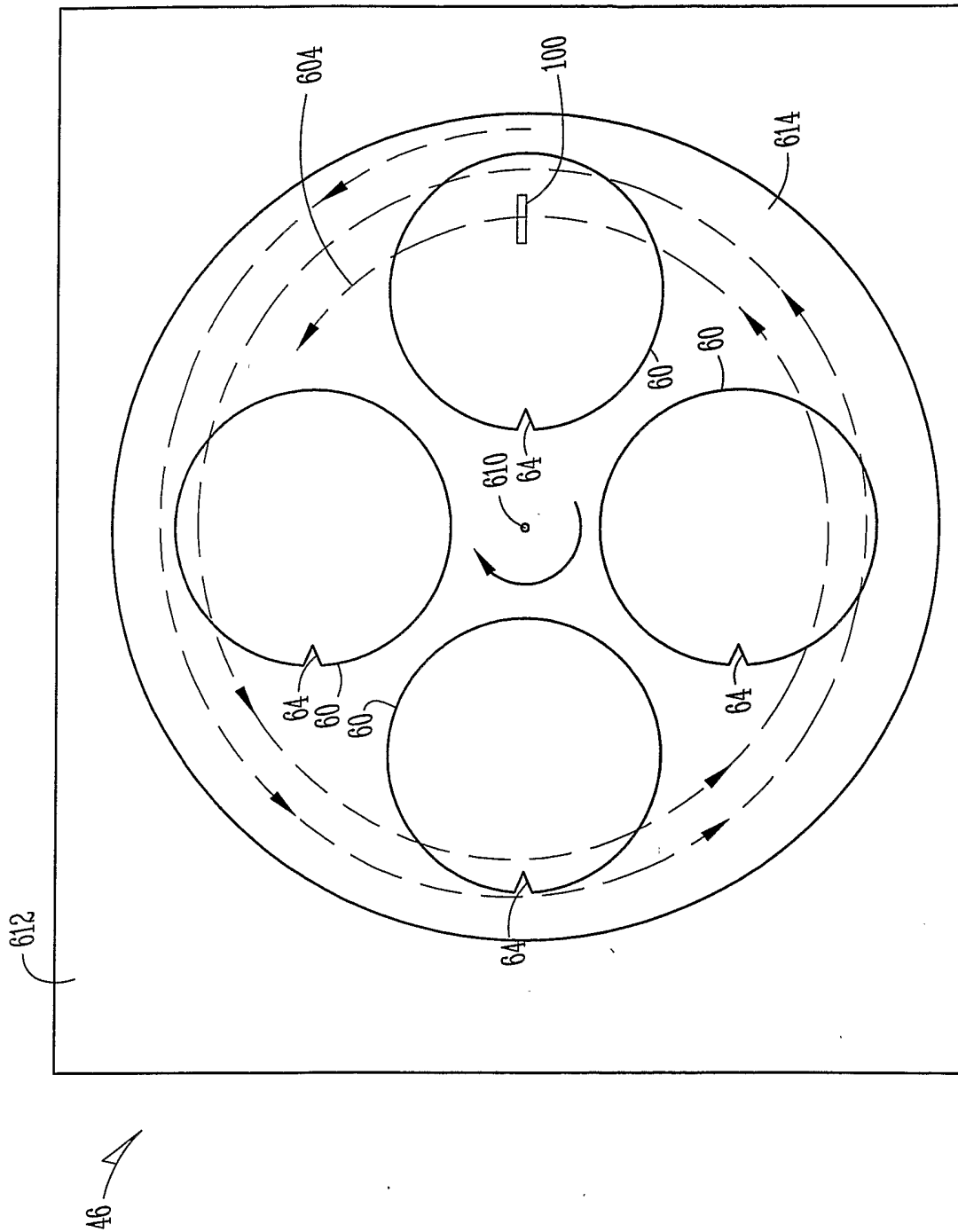

Fig. 12

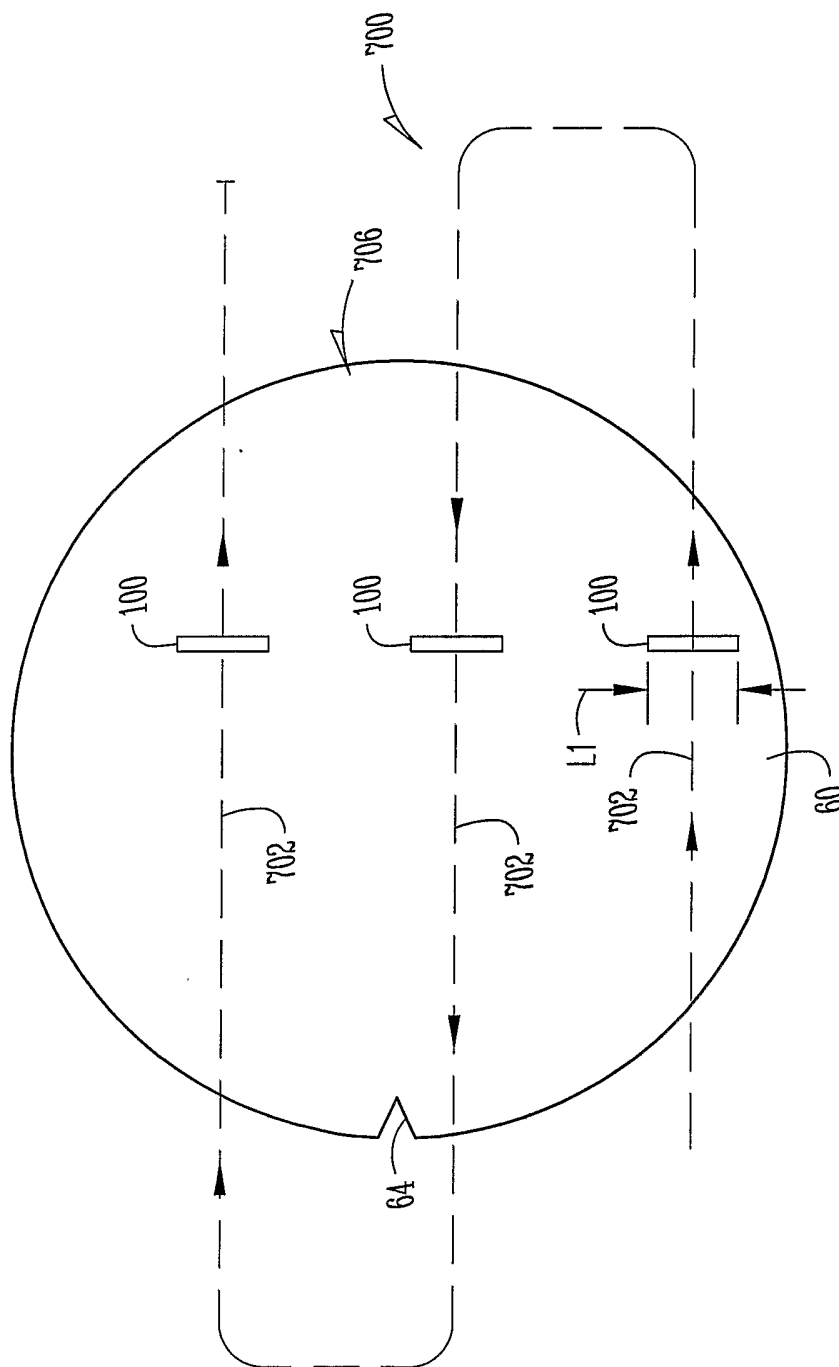

Fig. 13A

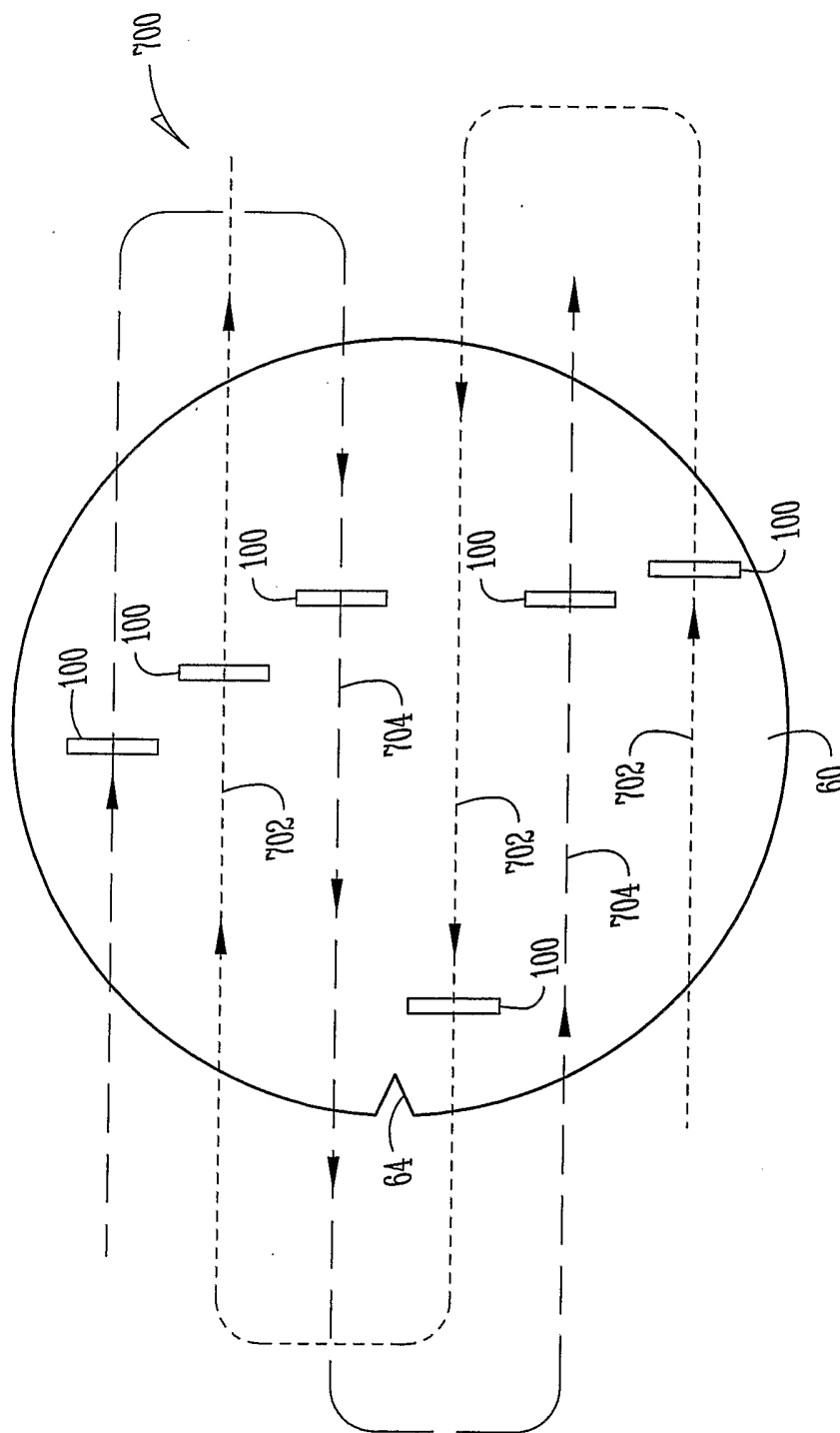

Fig. 13B

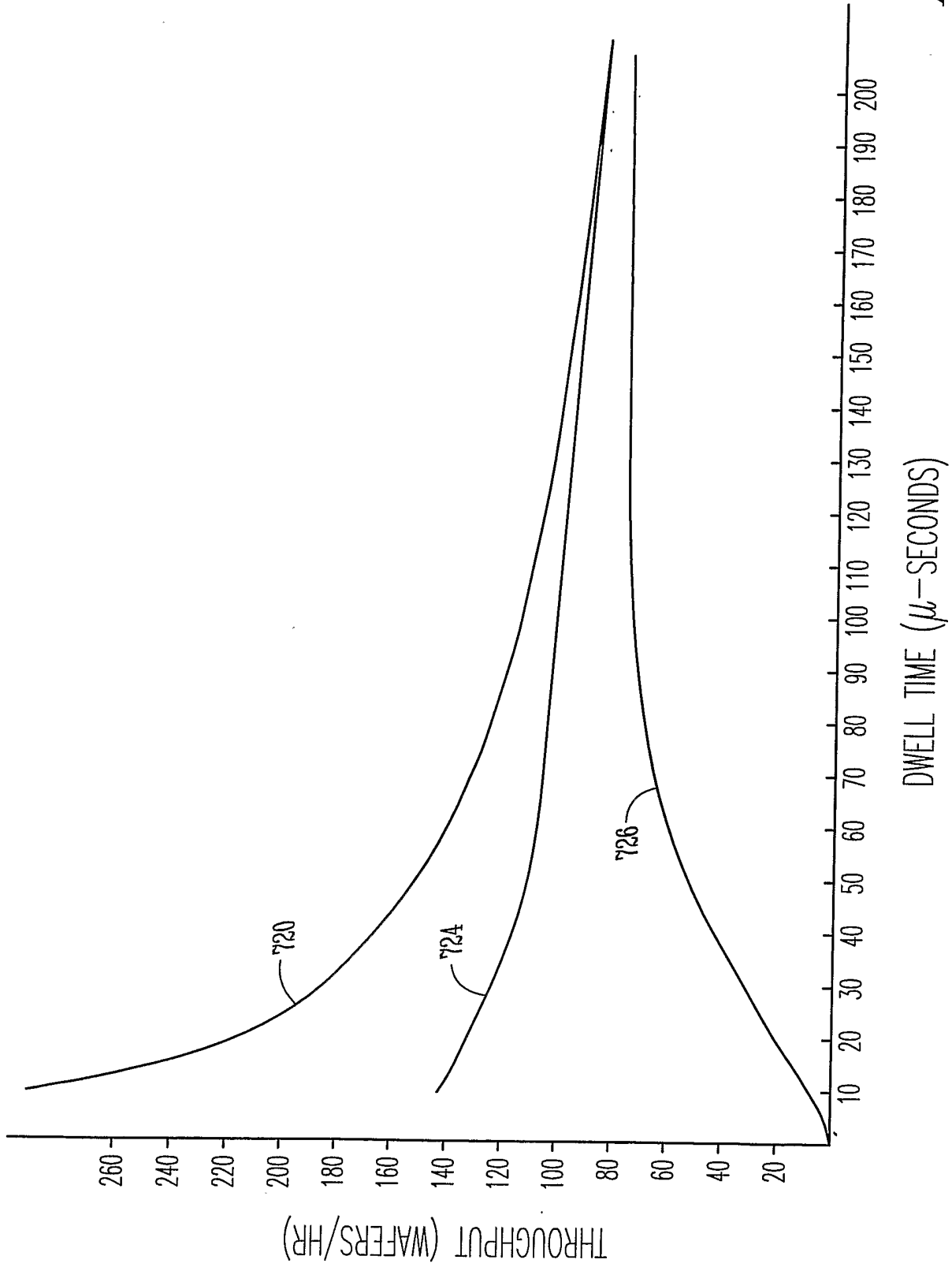

Fig. 14