

No. 771,095.

PATENTED SEPT. 27, 1904.

E. C. RICHARD,
GAS ENGINE.

APPLICATION FILED FEB. 18, 1902.

NO MODEL.

2 SHEETS—SHEET 1.

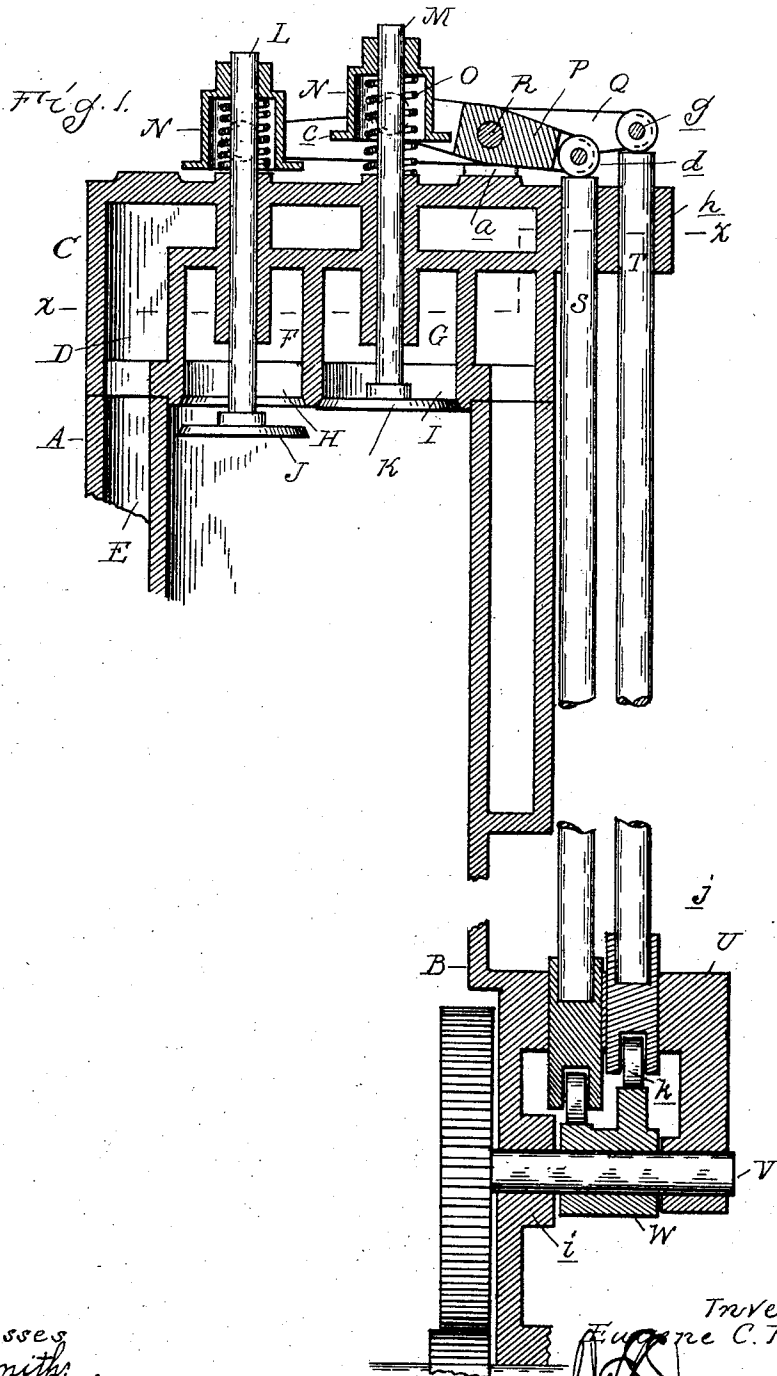

Witnesses
R. C. Smith
M. D. Ogilvie

Inventor
Eugene C. Richard
By *[Signature]*
Attys.

No. 771,095.

PATENTED SEPT. 27, 1904.

E. C. RICHARD.
GAS ENGINE.

APPLICATION FILED FEB. 18, 1902.

NO MODEL.

2 SHEETS—SHEET 2.

Fig. 2.

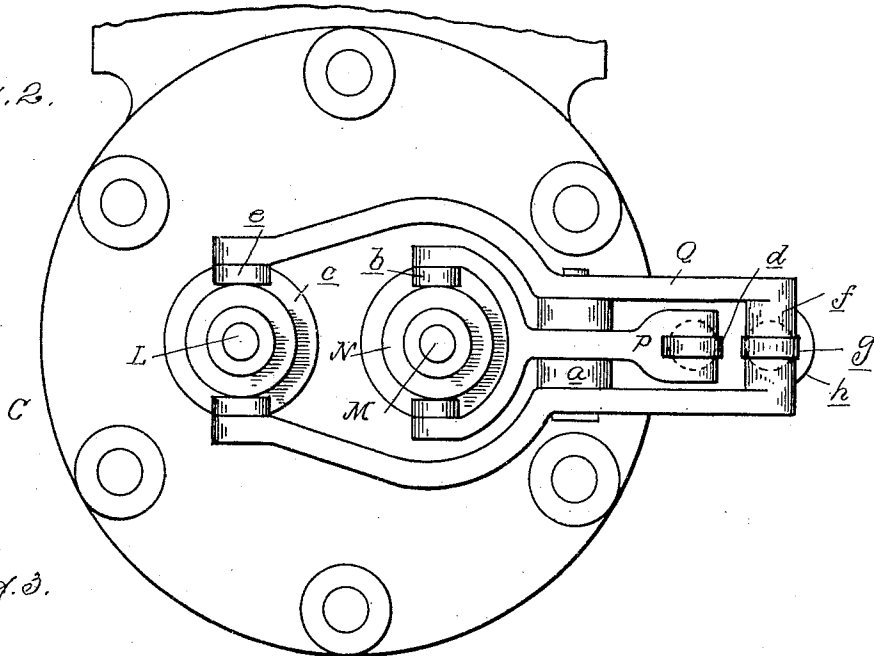
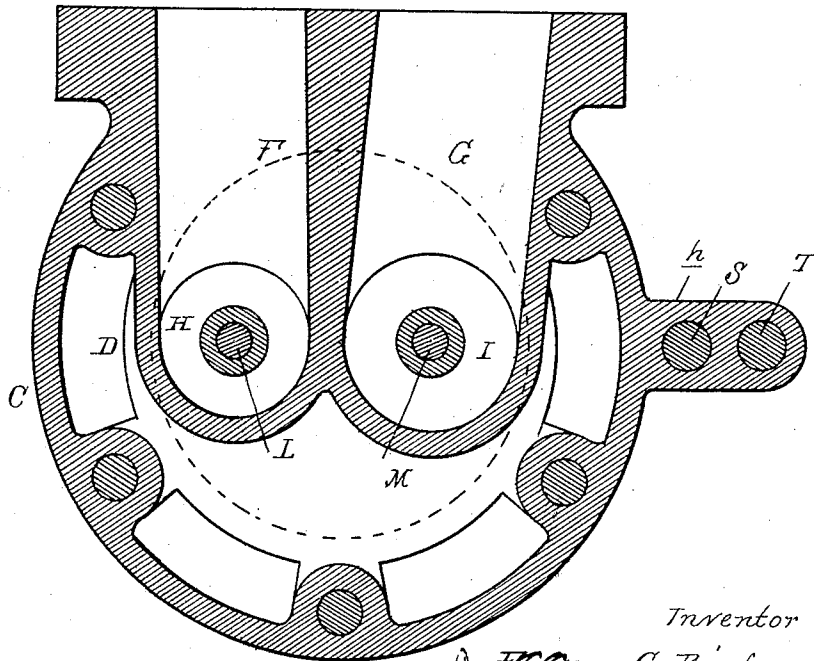

Fig. 3.



Inventor

Eugene C. Richard

Witnesses
H. C. Smith.
M. B. Ogden

By *[Signature]*
Attys.

UNITED STATES PATENT OFFICE.

EUGENE C. RICHARD, OF DETROIT, MICHIGAN, ASSIGNOR TO BUICK MANUFACTURING COMPANY, OF DETROIT, MICHIGAN, A CORPORATION OF MICHIGAN.

GAS-ENGINE.

SPECIFICATION forming part of Letters Patent No. 771,095, dated September 27, 1904.

Application filed February 18, 1902. Serial No. 94,682. (No model.)

To all whom it may concern:

Be it known that I, EUGENE C. RICHARD, a citizen of the United States, residing at Detroit, in the county of Wayne and State of Michigan, have invented certain new and useful Improvements in Gas-Engines, of which the following is a specification, reference being had therein to the accompanying drawings.

The invention relates to explosion-engines; and it consists in the peculiar construction, arrangement, and combination of parts, as hereinafter described and claimed.

In the drawings, Figure 1 is a longitudinal section through the engine. Fig. 2 is a plan view thereof; and Fig. 3 is a horizontal section on line *x x*, Fig. 1.

A is the engine-cylinder, which is preferably formed integral with a standard B, which forms an inclosing casing for the connecting-rod and crank. (Not shown.)

C is a valve-chest, which is of cylindrical form and is arranged to form an extension of the cylinder A. This chest is formed with the water-chamber D therein, which communicates with the chamber E, formed between the outer jacket and inner wall of the cylinder. Centrally within the chest are formed two adjacent chambers F and G, respectively, constituting the induction and eduction ports for the cylinder. These chambers are provided with ports H and I, opening into the cylinder, which are controlled by inwardly-opening valves J and K. These valves are provided with stems L and M, passing outward through the top of the chest.

N represents collars secured to the upper ends of the stems L and M, which are preferably cupped to receive the springs O, which draw the valves to their seats and are sleeved upon said stems.

P and Q are levers for operating the valves, which are fulcrumed upon a common pivot R, secured to a lug *a*, projecting upward from the chest. The lever P is preferably arranged between furcations of the lug *a* and at its inner end is bifurcated to embrace the collar N, being also provided with rolls *b*, adapted to bear upon a flange *c* of said collar. The outer

end of the lever is also provided with an anti-friction-roll *d*, which is adapted to rest upon the upper end of an operating-rod S. The lever Q is composed of two like members arranged upon opposite sides of the lever P and secured to the pin R outside of the furcations of the lug *a*. These members are also curved outwardly, so as to clear the bifurcated end of the lever P, and are then drawn inward again and provided with rolls *e* for engaging with the flange *c* of the collar end. At the outer end of the lever Q the two members are provided with inwardly-projecting lugs *f*, between which is journaled an anti-friction-roll *g*, adapted to rest upon the operating-rod T. The rods S and T are slidingly secured in bearings upon the engine-casing, their upper ends preferably engaging with an apertured lug *h*, projecting laterally from the side of the chest C. The lower ends of these rods are also slidingly secured in bearings, which are preferably formed in a bracket U, projecting from the crank-casing, said bracket also forming a bearing for the outer end of the cam-shaft V.

W is the operating-cam, which is secured to the shaft V between the bracket U and the hub *i* upon the crank-casing. The inner end of the shaft V is provided with a two-to-one gearing connecting it with the crank-shaft, whereby the cam will complete a revolution for every two revolutions of the crank. The bearings of the rods S and T upon the cam are preferably formed by providing heads *j* with sockets at their upper ends in which said rods engage, while at their lower ends are pivoted anti-friction-rolls *k*, which bear against the cam.

The construction being as shown and described, in operation the movement of the cam W will impart properly-timed movement to the rods S and T, which in turn will actuate the levers P and Q and through the medium of the collars N will operate the valves J and K.

The chambers F and G, which connect with the ports H and I, preferably extend to one side of the head C.

The construction described is especially designed with a view to simplicity and ease in

manufacture and also the facility with which the parts may be assembled or detached when necessary. Thus the valve-levers being fulcrumed upon a common pin may be readily removed and the rods S and T may then be drawn out from their bearings. At the same time the construction is such that the operation is positive, and wear of parts is prevented by the antifriction-bearing.

10 The cylindrical form of the valve-chest and its arrangement as an extension of the cylinder with the valve-chambers centrally therein provides abundant space for the cooling agent, and thus the carbonization of the lubricating-
15 oil upon the valve-stems is prevented.

What I claim as my invention is—

1. In an explosion-engine, the combination with the cylinder, a valve-stem passing outward through the head of said cylinder, a spring sleeved upon said stem, a cupped collar secured to said stem and forming a bearing for said spring, an outwardly-projecting flange in said collar, a bifurcated lever having antifriction-rolls bearing upon said flange on
20 opposite sides of said collar, a lug on said head to which said lever is pivoted, a push-rod slidingly secured in a bearing at the side of said head and an antifriction-roll secured to the opposite end of said lever bearing
25 against the end of said push-rod.

2. In an explosion-engine, the combination

with a cylinder, of induction and eduction valves having their stems projecting outward through the head of said cylinder, collars on said stems, bifurcated levers engaging with
35 said collars a common fulcrum-pin for said levers secured to a lug on said head, and parallel push-rods slidingly secured in bearings at the side of said head and respectively bearing against the outer ends of said levers. 40

3. In an explosion-engine, the combination with the cylinder-head, of induction and eduction valves having their stems projecting outward through said head, collars on said stems, the lever P having the bifurcated end embracing and bearing upon the collar of the adjacent stem; the two-part lever Q having its members arranged upon opposite sides of the lever P, one end of each bearing upon the collar of the other valve and the opposite ends
45 extending beyond the outer end of the lever P and being joined together, parallel push-rods for actuating the outer ends of said levers, and a pin forming a common fulcrum for said levers detachably secured to a lug on
50 said head. 55

In testimony whereof I affix my signature in presence of two witnesses.

EUGENE C. RICHARD.

Witnesses:

M. B. O'DOHERTY,

H. C. SMITH.